

**COLCHESTER ARCHAEOLOGICAL REPORT 7:**

**Post-Roman pottery from  
excavations in Colchester, 1971-85**

## **Colchester Archaeological Reports**

General Editor: Philip Crummy

Published by the Colchester Archaeological Trust Ltd

**Report 1:** *Aspects of Anglo-Saxon and Norman Colchester*

by Philip Crummy (CBA Research Report **39**), 1981

ISBN 0 906780 06 3

Published jointly by the Colchester Archaeological Trust and the Council for British Archaeology, 112 Kennington Road, London SE11 6RE

**Report 2:** *The Roman small finds from excavations in Colchester, 1971-9*

by Nina Crummy, 1983

ISBN 0 9503727 3 0

**Report 3:** *Excavations at Lion Walk, Balkerne Lane, and Middleborough, Colchester, Essex*

by Philip Crummy, 1984

ISBN 0 9503727 4 9

**Report 4:** *The coins from excavations in Colchester, 1971-9*

by Nina Crummy (ed), 1987

ISBN 0 9503727 6 5

**Report 5:** *The post-Roman small finds from excavations in Colchester, 1971-85*

by Nina Crummy, 1988

ISBN 0 9503727 7 3

**Report 6:** *Excavations at Culver Street, the Gilbert School, and miscellaneous sites in Colchester, 1971-85*

by Philip Crummy (ed), 1992

ISBN 0 9503727 9 X

**Report 8:** *Roman vessel glass from excavations in Colchester, 1971-85*

by H E M Cool and Jennifer Price, 1995

ISBN 1 897719 02 7

**Report 9:** *Excavations of Roman and later cemeteries, churches and monastic sites in Colchester, 1971-88*

by Nina Crummy, Philip Crummy, and Carl Crossan, 1993

ISBN 0 897719 01 9

**Report 10:** *Roman pottery from excavations in Colchester, 1971-86*

by Robin P Symonds & Sue Wade, 1999

ISBN 1 897719 07 8

**Report 11:** *Camulodunum 2*

by C F C Hawkes and Philip Crummy, 1995

ISBN 0 897719 03 5

**Report 12:** *Animal bone from excavations in Colchester, 1971-85*

by Rosemary Luff, 1993

ISBN 1 897719 00 0

COLCHESTER  
ARCHAEOLOGICAL  
REPORT 7:

Post-Roman pottery from  
excavations in Colchester, 1971-85

by  
JOHN P COTTER

*Principal illustrators:*

John Hepburn, Raphael Nazroo, Alex Scott

*Other illustrators:*

Sue Barnett, Fran Buxton, Simon Buxton  
John Callaghan, Terry Cook, John P Cotter, Robert Moyes

*Contributions from:*

Catherine Hills and M J Hughes



ENGLISH HERITAGE



COLCHESTER ARCHAEOLOGICAL TRUST LTD

© 2000 Colchester Archaeological Trust Ltd  
and English Heritage

Published in 2000 by  
Colchester Archaeological Trust Ltd,  
12 Lexden Road,  
Colchester,  
Essex CO3 3NF.

British Library Cataloguing-in-Publication Data  
Cotter, John P  
Post-Roman pottery from excavations in  
Colchester, 1971-85 —  
(Colchester archaeological report,  
ISSN 0264-6013; 6)  
I. Title II. Series  
936.26723

ISBN 1 897719 08 6

DTP by Colchester Archaeological Trust  
Printed from disk by Print Wright, Ipswich

The principal officers of the Colchester Archaeological  
Trust (formerly the Colchester Excavation Committee)  
since 1971 —

*Presidents:* Lord Alport (1965-72)  
Sir Mortimer Wheeler (1972-6)  
Professor S S Frere (1976- )

*Chairmen:* M R Hull (1971)  
Major J G S Brinson (1971-4)  
Dr M S Tite (1974-9)  
F H Thompson (1979-82)  
Professor J J Wilkes (1982-7)  
Mark Hassall (1987- )

*Honorary Secretaries:* Major J G S Brinson (1964-72)  
D T-D Clarke (1972-88)  
G M R Davies (1988-92)  
N Wickenden (1992- )

*Honorary Treasurers:* C S Buck (1969-75)  
I McMaster (1975-80)  
S G Maddison (1980-89)  
J Greenwood (1989-94)

*Director and General Editor:* Philip Crummy (1971- )

The Colchester Archaeological Trust  
acknowledges with gratitude the grant  
towards the publication of this volume from  
**English Heritage.**

# Contents

List of illustrations . . . . .	x
List of colour photographs . . . . .	xiii
Acknowledgements . . . . .	xiv
<b>Chapter 1. Introduction</b>	
Aims of the report . . . . .	1
The sites: general characteristics . . . . .	1
The site code reference system . . . . .	3
The sites: a gazetteer . . . . .	3
Methodology	
Quantities: some figures . . . . .	11
Classification and methods . . . . .	12
Essex post-Roman pottery codes . . . . .	12
Reference collections and archives . . . . .	13
Pottery dating and ceramic phasing . . . . .	14
Pottery dating methods . . . . .	14
Ceramic phasing . . . . .	15
Explanation of the bar charts . . . . .	16
Historical background . . . . .	17
Earlier work . . . . .	19
<b>Chapter 2. English wares: early to mid-Saxon</b> (c 450-850)	
Saxon 'brickearth' fabrics (Fabric 97) . . . . .	21
Dating . . . . .	22
Saxon vegetable-tempered ware (Fabric 1) . . . . .	23
Fabric . . . . .	23
Forms . . . . .	24
Decoration . . . . .	24
Discussion and dating . . . . .	24
Ipswich ware (Fabric 8) . . . . .	26
?Mid-Saxon wheel-turned 'bottle' (Fabric 8V) . . . . .	27
Oolitic wares (Fabric 12D) (see below) . . . . .	27
<b>Chapter 3. English wares: late Saxon and early medieval</b> (c 850-1200)	
Thetford-type wares (Fabric 9) . . . . .	28
Vessel forms . . . . .	28
Decoration . . . . .	30
Distribution of Thetford-type wares in Colchester . . . . .	30
Dating and origins of Thetford-type wares in Colchester . . . . .	31
St Neots-type ware (Fabric 10) . . . . .	32
Stamford ware (Fabric 11A) . . . . .	33
Early medieval shelly wares (Fabric 12) . . . . .	34
Early medieval shelly wares without sand (Fabric 12A) . . . . .	34
Fabric . . . . .	34
Form . . . . .	34
Dating . . . . .	35
Early medieval slightly sandy shelly wares (Fabric 12B) . . . . .	35
Early medieval sandy shelly wares (sand predominant) (Fabric 12C) . . . . .	36
Dating and discussion . . . . .	36
Oolitic wares (Fabric 12D) . . . . .	37
Mid-Saxon forms . . . . .	38
Early medieval forms . . . . .	39
Source and dating . . . . .	39
Early medieval sandy wares (Fabrics 13, 13S and 13T) . . . . .	39
Fabric . . . . .	39
Dating . . . . .	40
Vessel forms	
Cooking pots/jars . . . . .	41
Storage jars . . . . .	44
Straight-sided jars . . . . .	44
Spouted pitchers . . . . .	44
Handled skillets . . . . .	47
Rims . . . . .	47
Cooking-pot and jar diameters . . . . .	49
Decoration: cooking pots and related forms . . . . .	49
Bowls . . . . .	52
Pierced-lug bowls . . . . .	55
Less common forms:	
Curfews or fire-covers . . . . .	55
Jugs . . . . .	55
Crucibles or globular lamps . . . . .	55
Other lamps . . . . .	55
Miscellaneous . . . . .	55
Textile and other impressions . . . . .	56
Medieval pottery kilns at Middleborough	
The kilns and related structures . . . . .	57
The pottery . . . . .	57
Cooking pots and related forms . . . . .	57
Decoration: cooking pots and related forms . . . . .	64
Manufacture: cooking pots and related forms . . . . .	64
Bowls . . . . .	65
Jugs . . . . .	65
Curfews . . . . .	65
Miscellaneous . . . . .	65
Similarity of the kilns . . . . .	66
Dating and life span of kilns . . . . .	67
Origins and affinities of Colchester Fabric 13 and summary of main developments . . . . .	68
<b>Chapter 4. English wares: medieval</b> (c 1200-1550)	
London-type ware (Fabric 36) . . . . .	72
Form and decoration . . . . .	73
1. Early rounded jugs . . . . .	73
2. Squat jugs . . . . .	73
3. Rouen-style baluster jugs . . . . .	73
4. Other jug types . . . . .	73

5. Other forms . . . . .	73	Late Colchester-type ware (c 1400/25-1550) . . . . .	108
Dating and discussion. . . . .	73	Sources	
Scarborough ware (Fabric 24) . . . . .	74	a. Essex and East Anglian redwares . . . . .	109
Other Yorkshire wares (Fabric 24X) . . . . .	75	b. Colchester-type ware . . . . .	109
Hedingham ware (Fabric 22) . . . . .	75	Dating and quantification (c 1200-1550) . . . . .	111
Fabric . . . . .	76	Vessel typology . . . . .	113
Form and decoration. . . . .	76	Jugs . . . . .	113
1. Early rounded jugs . . . . .	76	Baluster jugs . . . . .	113
Decoration . . . . .	77	a. White-slipped ('early style') baluster jugs . . . . .	113
2. Rouen-style jugs. . . . .	79	b. Baluster jugs with ('early style') applied strips or thick slip painting . . . . .	115
Decoration . . . . .	79	c. Baluster jugs with ('middle style') thin slip painting . . . . .	115
3. Stamped strip jugs . . . . .	81	d. Late medieval 'metal copy' baluster jugs . . . . .	118
Decoration . . . . .	81	e. Miscellaneous unslipped baluster jugs . . . . .	118
4. Squat jugs . . . . .	81	Squat jugs . . . . .	118
5. Pear-shaped or biconical jugs . . . . .	82	a. White-slipped ('early style') squat jugs . . . . .	118
6. Miscellaneous jugs . . . . .	82	b. Squat jugs with ('early style') thick slip painting . . . . .	118
Construction. . . . .	82	c. Squat jugs with ('middle style') thin slip painting . . . . .	118
Other forms . . . . .	83	d. Squat jugs with ('late style') thin slip painting . . . . .	120
Discussion and dating		Small rounded jugs. . . . .	122
1. Hedingham ware from Essex and elsewhere . . . . .	83	'Cheam copy' jugs . . . . .	122
2. Dating evidence from Colchester . . . . .	84	Late medieval conical or cylindrical jugs. . . . .	122
3. Origins and affinities of the Hedingham ware industry . . . . .	86	Miscellaneous jugs . . . . .	122
4. Distribution. . . . .	90	Miscellaneous decorated jug sherds . . . . .	124
Summary . . . . .	91	Jugs and their dating . . . . .	127
Medieval sandy greywares (Fabric 20)		Baluster jugs	
Fabric . . . . .	91	a. White-slipped ('early style') baluster jugs . . . . .	127
Dating and frequency . . . . .	91	b. Baluster jugs with ('early style') applied strips or thick slip painting . . . . .	127
Sources, parallels and distribution . . . . .	92	c. Baluster jugs with ('middle style') thin slip painting . . . . .	128
Cooking pots . . . . .	94	d. Late medieval 'metal copy' baluster jugs . . . . .	128
Function . . . . .	97	e. Miscellaneous unslipped baluster jugs . . . . .	128
Bowls . . . . .	98	Squat jugs	
Jugs . . . . .	98	a. White-slipped ('early style') squat jugs . . . . .	128
Miscellaneous forms . . . . .	101	b. Squat jugs with ('early style') thick slip painting . . . . .	128
Storage jars . . . . .	101	c. Squat jugs with ('middle style') thin slip painting . . . . .	128
Skillets . . . . .	104	d. Squat jugs with ('late style') thin slip painting . . . . .	128
Frying pan . . . . .	104	Small rounded jugs. . . . .	128
Cisterns . . . . .	104	'Cheam copy' jugs . . . . .	128
Bottles or measures . . . . .	104	Late medieval conical or cylindrical jugs. . . . .	128
?Industrial vessel . . . . .	104	Miscellaneous jugs and decorated sherds . . . . .	129
Dripping pans. . . . .	104	Jugs: function, miscellaneous markings and secondary use . . . . .	129
?Water sprinkler . . . . .	104	Jars . . . . .	129
Curfews or fire-covers. . . . .	104	Cisterns . . . . .	129
Lids . . . . .	104	Miscellaneous 'storage' jars. . . . .	134
Perforated sherds and secondary use . . . . .	106	Cooking pots and related forms . . . . .	138
Louvers . . . . .	106		
Chimney pots or drain-pipes . . . . .	106		
Summary of principal developments in Fabric 20 . . . . .	106		
Group A forms (c 1175-1250/75)			
Cooking pots . . . . .	106		
Jugs . . . . .	107		
Bowls . . . . .	107		
Group B forms (c 1250/75-1375/1400) . . . . .	107		
Cooking pots . . . . .	107		
Jugs . . . . .	107		
Bowls . . . . .	107		
Colchester-type ware (Fabric 21A) . . . . .	107		
Introduction . . . . .	107		
Fabric . . . . .	108		
Early Colchester-type ware (c 1200-1375/1400) . . . . .	108		

Jars with external lid-seating and related forms . . . . .	141	Problems in characterising Fabric 40 . . . . .	191
Pipkins and skillets . . . . .	143	<i>c</i> 1500-1650: fine Central Essex-type fabric . . . . .	192
Bowls . . . . .	143	<i>c</i> 1550-1750/1800: 'standard' fabric . . . . .	192
Dishes, small bowls and condiments . . . . .	143	<i>c</i> 1675-1850: low-fired and 'brickearth' fabrics . . . . .	192
Large bowls or pancheons . . . . .	143	19th- and 20th-century Fabric 40 . . . . .	193
Cups and drinking vessels . . . . .	149	Typology . . . . .	194
Miscellaneous forms . . . . .	150	Dishes . . . . .	194
Chafing dishes . . . . .	150	Bowls . . . . .	194
Pierced vessels . . . . .		Jars . . . . .	203
Strainers . . . . .	154	Cisterns . . . . .	203
Lid or fire-cover . . . . .	154	Large storage jars . . . . .	203
Fuming pot . . . . .	154	Smaller jars and chamberpots . . . . .	207
Water sprinklers . . . . .	154	Pipkins, skillets and cauldrons . . . . .	207
Costrels or bottles . . . . .	154	Miscellaneous jars . . . . .	210
Lids . . . . .	155	Sugar-refining jars . . . . .	210
Dripping pans . . . . .	156	Jugs . . . . .	210
<i>Aquamaniles</i> . . . . .	156	Cups, mugs and tygs . . . . .	212
Mortar . . . . .	156	Miscellaneous forms . . . . .	
Industrial vessels . . . . .	156	Chafing dishes . . . . .	212
Candlemaker's troughs . . . . .	156	Condiments . . . . .	212
Inkwells or miscellaneous unidentified forms . . . . .	159	Costrels . . . . .	212
Louvers . . . . .	159	Lids . . . . .	212
Louvers: discussion . . . . .	163	Water pipes . . . . .	215
Louvers: dating and context . . . . .	164	Oval 'casseroles' or 'brining troughs' . . . . .	215
Roof finials and other roof furniture . . . . .	166	Dripping pans . . . . .	215
Sgraffito ware . . . . .	166	Pierced vessels . . . . .	215
Slip decoration: an outline of its stylistic development on Colchester-type ware . . . . .	171	Firepots . . . . .	215
Early style ( <i>c</i> 1200-1375/1400) . . . . .	172	Strainers or cheese presses . . . . .	215
Middle or transitional style ( <i>c</i> 1375-1450) . . . . .	172	Flowerpots . . . . .	215
Late style ( <i>c</i> 1450-1525/50) . . . . .	173	Bed-warming pan . . . . .	217
Colchester-type ware: origins, affinities and decline . . . . .	174	Bird pot . . . . .	218
Distribution . . . . .	177	Moneybox . . . . .	218
Conclusion . . . . .	180	Puzzle jug . . . . .	218
Mill Green ware (Fabric 35) . . . . .		A group of vessels from a Civil War fort, Sheepen, Colchester . . . . .	218
Fabric . . . . .	180	Buried pots at Middleborough . . . . .	219
Form and decoration . . . . .	181	Metropolitan slipware (Fabric 40A) . . . . .	221
1. Pear-shaped jugs . . . . .	181	Border ware (Fabric 42) . . . . .	225
2. Baluster jugs . . . . .	181	Netherlands, Anglo-Netherlands and English tin-glazed earthenwares (Fabric 46) . . . . .	228
3. Squat jugs . . . . .	181	Drug jars, apothecaries and pit groups . . . . .	229
4. Rounded jugs . . . . .	182	Apothecaries at Lion Walk in the 17th and 18th centuries . . . . .	230
Decoration . . . . .	182	Pit group LWC KF15 . . . . .	232
Dating . . . . .	182	Pit group LWC VF2 . . . . .	234
Discussion . . . . .	182	Pit group LWC BF14 . . . . .	234
Kingston-type ware (Fabric 23D) . . . . .	182	Lion Walk 'C' pit complex . . . . .	235
Coarse Border ware (Fabric 23F) . . . . .	183	Drug jars . . . . .	
Cheam white ware (Fabric 23E) . . . . .	183	(from the pit complex and other contexts) . . . . .	235
'Tudor Green' ware (Fabric 41) . . . . .	184	Dishes and plates . . . . .	237
Cistercian ware (Fabric 40C) . . . . .	184	Bowls . . . . .	243
Miscellaneous unidentified medieval and post-medieval wares, probably English (Fabric 98) . . . . .	185	Other forms . . . . .	244
Fabric 98: miscellaneous . . . . .	186	The pharmaceutical inscriptions . . . . .	244
'Long Wyre Street' ware (Fabric 98W) . . . . .	186	North Devon gravel-tempered ware (Fabric 56) . . . . .	245
Non-local slip-painted ware (Fabric 98S) . . . . .	186	English stonewares (Fabric 45) . . . . .	245
<b>Chapter 5. English wares: post-medieval (<i>c</i> 1550-1750)</b>		Wrotham slipware (Fabric 40D) . . . . .	247
Guy's-type ware (Fabric 55) . . . . .	187	Staffordshire-type slipware (Fabric 50) . . . . .	248
Post-medieval red earthenwares (Fabric 40) . . . . .	189	Staffordshire-type iron-streaked earthenware (Fabric 50A) . . . . .	249

**Chapter 6. English wares: modern (c 1750 onwards)**

Modern English wares . . . . .	250
Documentary sources . . . . .	250
Catalogue of modern wares . . . . .	251
Red stoneware (Fabric 48R) . . . . .	251
Nottingham/Derbyshire stoneware (Fabric 45G) . . . . .	252
Staffordshire-type white stoneware (Fabric 47) . . . . .	252
Jackfield ware (Fabric 48J) . . . . .	252
Whieldon-type wares (Fabric 48W) . . . . .	253
Creamware (Fabric 48C) . . . . .	253
Basalt ware (Fabric 49) . . . . .	253
Yellow ware (Fabric 48E) . . . . .	253
Staffordshire-type white earthenwares (Fabric 48D) . . . . .	253
English porcelain (Fabric 48B) . . . . .	254
Modern English stoneware (Fabric 45M) . . . . .	254
Late slipped kitchenware (Fabric 51A) . . . . .	254
Sussex inlaid slipware (Fabric 40E) . . . . .	256
Lustre ware (Fabric 48L) . . . . .	256
Flowerpot (Fabric 51B) . . . . .	256
Sanitary wares (Fabric 48V) . . . . .	256
Miscellaneous earthenwares (Fabric 48X) . . . . .	257

**Chapter 7. French wares**

An outline of contact with France . . . . .	258
Wheel-thrown Frankish sandy wares (Fabric 97F) . . . . .	258
'Pudding Lane'-type North French glazed ware (Fabric 95P) . . . . .	261
Unprovenanced French micaceous ware (Fabric 95M) . . . . .	261
Rouen-type ware (Fabric 28) . . . . .	261
Saintonge ware (Fabric 27) . . . . .	262
Beauvais earthenwares (Fabric 30) . . . . .	262
Beauvais stoneware (Fabric 45J) . . . . .	263
Martincamp flasks (Fabric 43) . . . . .	264
Normandy stoneware (Fabric 45N) . . . . .	264

**Chapter 8. Low Countries wares**

An outline of contact with the Low Countries . . . . .	265
Brunssum-Schinveld ware (Fabric 14B) . . . . .	265
Andenne ware (Fabric 17) . . . . .	266
Miscellaneous early medieval Low Countries white wares (Fabric 17X) . . . . .	266
Low Countries red earthenwares (Fabric 31) . . . . .	266
Jars: cauldrons and pipkins . . . . .	267
Skillets . . . . .	267
Dishes and bowls . . . . .	270
Strainers . . . . .	270
Porringers and drinking vessels . . . . .	270
Dripping pans . . . . .	270
Curfews . . . . .	270
Miscellaneous . . . . .	272
North Holland slipware (Fabric 31A) . . . . .	272
Low Countries white earthenwares (Fabric 23C) . . . . .	274
South Netherlands <i>maiolica</i> (Fabric 46C) Flower vases . . . . .	274

**Chapter 9. German and Rhenish wares**

An outline of contact with Germany . . . . .	276
Pingsdorf-type ware (Fabric 14A) . . . . .	276
Paffrath-type ware (Fabric 18) Fabric . . . . .	276
Rhenish stonewares . . . . .	277
Siegburg stoneware (Fabric 45B) . . . . .	277
Green-glazed Sieberg . . . . .	278
Langerwehe stoneware (Fabric 45A) . . . . .	278
Gothic (Saxony) stoneware (Fabric 45K) . . . . .	280
Raeren stoneware (Fabric 45C) . . . . .	281
Cologne and Frechen stonewares (Fabrics 45E and 45D) . . . . .	282
Westerwald stoneware (Fabric 45F) . . . . .	288
'Hessian' crucibles (Fabric 60) . . . . .	288
German slipwares (Fabric 44) Weser slipware (Fabric 44A) . . . . .	290
Werra slipware (Fabric 44B) . . . . .	292
Lower Rhine slipware (Fabric 44C) . . . . .	292
Nieder Selters-type bottles (Fabric 45S) . . . . .	293

**Chapter 10. Iberian wares**

An outline of contact with the Iberian peninsula . . . . .	294
Spanish lustrewares (Fabric 46B) Andalusian lustreware (Fabric 46B/1) . . . . .	294
Valencian lustreware (Fabric 46B/2) . . . . .	294
Seville ( <i>Cuerda Seca</i> ) (Fabric 46D/1) . . . . .	296
Seville ( <i>maiolica</i> ) (Fabric 46D/2) . . . . .	296
Olive jars (Fabric 29A) . . . . .	296
Miscellaneous Iberian green glazed wares (Fabric 29X) . . . . .	297
Merida-type ware (Fabric 57) . . . . .	297
Iberian/North African star costrels (Fabric 62) . . . . .	297
Portuguese <i>maiolica</i> (Fabric 46F) . . . . .	297
Iberian storage jars (Fabric 53) . . . . .	297

**Chapter 11. Italian wares**

An outline of contact with Italy . . . . .	299
Italian <i>maiolica</i> (Fabric 46E) . . . . .	299
Montelupo . . . . .	299
North Italian marbled slipware (Fabric 39) . . . . .	300
Italian oil jars (Fabric 54) . . . . .	300
Catalogue of Italian oil jars from Colchester . . . . .	301

**Chapter 12. Far Eastern wares**

An outline of contact with the Far East . . . . .	306
Martabani stoneware (Fabric 58) . . . . .	306
Chinese porcelain (Fabric 48A) . . . . .	306

**Chapter 13. Miscellaneous unsourced ?imports**

Unidentified foreign wares (Fabric 95) . . . . .	307
Mediterranean 'mercury' jars (Fabric 52) . . . . .	307

**Chapter 14. The stratified groups**

Introduction . . . . .	309
Selected stratified groups . . . . .	309
Group 1: (Hut 2) LWC HF63 (5th century) . . . . .	309
Group 2: (Hut 3) 1.81 BF4 (7th century) . . . . .	310
Group 3: CPS F106 (c 1000-1050) . . . . .	311



Group 4: LWC NF21 (c 1050-1300) . . . . .	311
Group 5: 1.81 HF365 (c 1125-1150). . . . .	316
Group 6: 1.81 GF163 (c 1175-1200) . . . . .	316
Group 7: COC F213 (c 1225-1275 or possibly c 1250) . . . . .	316
Group 8: COC F212 (c 1300-1325) . . . . .	322
Group 9: LWC MF22/F52/F53 (c 1382-1421) . . . . .	322
Group 10: LWC LF33 (c 1400-1450) . . . . .	323
Group 11: LWC BF45 (c 1425-1475) . . . . .	325
Group 12: LWC CF65 (c 1475-1525) . . . . .	325
Group 13: SPT F14 (c 1500-1525) . . . . .	328
Group 14: 1.81 EF14/F19 (c 1525). . . . .	328
Group 15: 1.81 HF39/F158 (c 1525-50) . . . . .	328
Group 16: LWC CF77/F22 (c 1550/75-1575/1600) . . . . .	331
Group 17: COC F61 (c 1625-1650) . . . . .	334
Group 18: LWC GF24 (c 1625-1650) . . . . .	334
Group 19: LWC VF2 (c 1650) . . . . .	334
Group 20: LWC BF14 (c 1650) . . . . .	337
Group 21: MID AF15 (c 1680-1700) . . . . .	344
Group 22: LWC RF18 (c 1730-1740) . . . . .	351

## Chapter 15. Conclusions

Introduction . . . . .	353
Development and supply of post-Roman pottery in Colchester	
Anglo-Saxon. . . . .	353
Norman . . . . .	353
Medieval . . . . .	354
Post-medieval. . . . .	354
English 'imports' as evidence for trade and cultural links. . . . .	354
Foreign imports and trade . . . . .	355
The broader picture. . . . .	355
Recommendations for future work . . . . .	355

## Appendices

### Appendix 1: Concordance of illustrated pottery . . . 357

### Appendix 2: Documentary evidence for potters and kiln-sites in the Colchester area

Introduction . . . . .	364
Sources . . . . .	364
Colchester and its borough . . . . .	364
Lexden. . . . .	364
Mile End . . . . .	365
Greenstead . . . . .	365
The walled town and intramural parishes . . . . .	366
Customs and ordinances affecting pottery . . . . .	367
Pottery and tile manufacture in adjacent parishes . . . . .	367
Great Horkesley . . . . .	367
Ardleigh . . . . .	367
East Donyland . . . . .	368
Wivenhoe. . . . .	368
Outlying areas . . . . .	368
Dedham . . . . .	368
Thorpe-le-Soken. . . . .	368
Tiptree . . . . .	369

### Appendix 3: Neutron activation analysis of redware pottery from north-east Essex, including Colchester-type wares *by M J Hughes*

Summary . . . . .	370
Introduction . . . . .	370
Selection of samples and reference analyses of pottery . . . . .	370
Neutron activation analysis and multivariate statistics. . . . .	372
Discussion . . . . .	372
Conclusions . . . . .	373

### Bibliography . . . . . 374

### Index . . . . . 380

### Colour photographs . . . . . 387

# Illustrations

## Chapter 1. Introduction

Fig 1	Location of sites . . . . .	2
2	The main sites: bar chart showing pottery quantities . . . . .	11
3	Key to drawing conventions . . . . .	14
4a-b	Ceramic phasing: bar charts showing sample size. . . . .	16

## Chapter 2. English wares: early to mid-Saxon

5	Saxon 'brickearth' wares . . . . .	21
6	Vegetable-tempered ware . . . . .	23
7	Ipswich ware. . . . .	26
8	?Mid-Saxon wheel-turned 'bottle' . . . . .	27

## Chapter 3. English wares: late Saxon and early medieval

9-10	Thetford-type wares . . . . .	29-30
11	St Neots-type ware . . . . .	32
12	Stamford ware . . . . .	34
13	Early medieval shelly wares without sand . . . . .	34
14	Early medieval slightly sandy shelly wares . . . . .	35
15	Early medieval sandy shelly wares (sand predominant). . . . .	37
16	Oolitic wares. . . . .	38
17	Early medieval sandy ware: bar chart showing percentages in stratified contexts. . . . .	41
18	Early medieval sandy ware: pie chart showing vessel assemblage . . . . .	42
19	Early medieval sandy ware: miscellaneous forms. . . . .	42
20	Early medieval sandy ware: cooking pots . . . . .	43
21	Early medieval sandy ware: manufacturing detail on cooking pot. . . . .	44
22-24	Early medieval sandy ware: cooking pots . . . . .	45-47
25	Early medieval sandy ware: storage jars. . . . .	48
26	Early medieval sandy ware: jars, spouted pitchers and skillets . . . . .	49
27	Early medieval sandy ware: diagram showing the main types of cooking- pot rim and date range . . . . .	50
28a-b	Early medieval sandy ware: bar charts showing diameters of cooking pot and jar rims . . . . .	51
29	Early medieval sandy ware: decoration details of storage jar and cooking pots. . . . .	52
30	Early medieval sandy ware: bowls . . . . .	53
31	Early medieval sandy ware: jugs and curfews . . . . .	54
32	Early medieval sandy ware: miscellaneous forms. . . . .	56
33-34	Middleborough kilns: cooking pots . . . . .	58-59
35	Middleborough kilns: selection of cooking- pot rims . . . . .	60

36	Middleborough kilns: spouted pitchers and bowls. . . . .	61
37	Middleborough kilns: storage jars . . . . .	62
38a-b	Middleborough kilns: bar charts showing rim diameters of cooking pots/jars . . . . .	63
39	Middleborough kilns: bowls . . . . .	64
40	Middleborough kilns: burnished jug sherds . . . . .	65
41	Middleborough kilns: miscellaneous forms. . . . .	66
42	Diagram showing timespan of the main forms in early medieval ware. . . . .	68

## Chapter 4. English wares: medieval

43	London-type ware: jugs and a louver fragment . . . . .	72
44	London-type ware: bar chart showing percentages in stratified contexts. . . . .	74
45	Scarborough ware . . . . .	74
46	Other Yorkshire wares. . . . .	75
47	Hedingham ware: bar chart showing percentages in stratified contexts. . . . .	76
48	Hedingham ware: jug sherds with plastic decoration . . . . .	77
49	Hedingham ware: early rounded jugs with plastic decoration . . . . .	78
50	Hedingham ware: Rouen-style jugs and stamped strip jugs . . . . .	80
51	Hedingham ware: jugs, lids and dripping pan . . . . .	82
52	Hedingham ware: diagram showing the timespan of the main Hedingham fine- ware jug forms . . . . .	85
53	Hedingham ware: distribution of Hedingham fine ware in East Anglia . . . . .	88
54	Medieval greyware: bar chart showing percentages in stratified contexts. . . . .	91
55	Medieval greyware: pie chart showing vessel assemblage . . . . .	92
56a-b	Medieval greyware: bar charts showing rim diameters of cooking pots/jars . . . . .	93
57	Medieval greyware: manufacturing detail of cooking pot . . . . .	94
58-59	Medieval greyware: cooking pots. . . . .	95-96
60	Medieval greyware: cooking pots, storage jars, and skillets or pipkins . . . . .	97
61	Medieval greyware: bowls . . . . .	99
62	Medieval greyware: bowls and frying pan. . . . .	100
63	Medieval greyware: manufacturing detail of rounded jug . . . . .	101
64-65	Medieval greyware: jugs . . . . .	102-103
66	Medieval greyware: miscellaneous forms . . . . .	105
67	Medieval greyware: miscellaneous forms c 1200-1350. . . . .	106
68	Medieval greyware: diagram showing the timespan of the main forms. . . . .	107

69	Colchester-type ware: bar chart showing percentages in stratified contexts . . . . .	111	109	Colchester-type ware: finials . . . . .	167
70	Colchester-type ware: pie chart showing vessel assemblage . . . . .	111	110	Colchester-type ware: roof furniture . . . . .	167
71	Colchester-type ware: baluster jugs . . . . .	114	111	Colchester-type ware: sgraffito-decorated forms — jugs, jars or cisterns, and condiment . . . . .	169
72	Colchester-type ware: baluster jugs with early style thick slip decoration . . . . .	115	112	Colchester-type ware: inscribed sgraffito jug sherd . . . . .	170
73-74	Colchester-type ware: baluster jugs . . . . .	116-117	113	Colchester-type ware: sgraffito-decorated forms — chafing dishes, crenellated lid and miscellaneous . . . . .	171
75	Colchester-type ware: squat jugs . . . . .	119	114	Colchester-type ware: bar chart showing slip usage (percentages of slipped sherds in stratified contexts) . . . . .	172
76	Colchester-type ware: jug handles . . . . .	120	115	Colchester-type ware: bar chart showing relative frequency of slip-application techniques . . . . .	172
77	Colchester-type ware: manufacturing details of jugs . . . . .	120	116	Colchester-type ware: miscellaneous forms . . . . .	173
78	Colchester-type ware: squat jugs . . . . .	121	117	Colchester-type ware: miscellaneous late forms . . . . .	174
79	Colchester-type ware: small round jugs, 'Cheam copy' jugs, conical jugs, and miscellaneous jug or measure . . . . .	123	118	Colchester-type ware: detail of late style decoration on small rounded jug . . . . .	177
80	Colchester-type ware: 'Cheam copy' jugs . . . . .	124	119	Colchester-type ware: distribution in Essex and adjoining areas . . . . .	178
81	Colchester-type ware: jug sherds with Rouen-style decoration . . . . .	124	120	Colchester-type ware: diagram showing estimated time span of the main forms . . . . .	179
82-83	Colchester-type ware: miscellaneous decorated jug sherds . . . . .	125-126	121	Mill Green ware: various jugs and decorated sherd . . . . .	181
84	Colchester-type ware: cisterns and cistern bung-holes . . . . .	131	122	Mill Green ware: bar chart showing percentages in stratified contexts . . . . .	182
85	Colchester-type ware: cisterns and cistern 'rosettes' . . . . .	132	123	Cheam white ware: jugs . . . . .	184
86	Colchester-type ware: cisterns with late style decoration . . . . .	133	124	'Tudor Green' ware: pedestal-footed cup . . . . .	184
87-88	Colchester-type ware: 'storage' jars . . . . .	135-136	125	Cistercian ware: cup, lid and stamped sherd . . . . .	185
89	Colchester-type ware: 'storage' jars and cooking pots or cauldrons . . . . .	137	126	Miscellaneous unidentified medieval English wares . . . . .	185
90	Colchester-type ware: cooking pots . . . . .	139	<b>Chapter 5. English wares: post-medieval</b>		
91	Colchester-type ware: cooking pots, jars and related forms . . . . .	140	127	Guy's-type ware: bowls and ?cauldron . . . . .	187
92	Colchester-type ware: jars, industrial vessel and pipkins . . . . .	142	128	Post-medieval red earthenwares: bar chart showing percentages in stratified contexts . . . . .	189
93	Colchester-type ware: pipkins, skillets, and small dishes or condiments . . . . .	144	129	The location of post-medieval potteries in Essex . . . . .	190
94	Colchester-type ware: small dishes or ?frying pans and large bowls or pancheons . . . . .	145	130	Post-medieval red earthenwares: pie chart showing vessel assemblage . . . . .	193
95	Colchester-type ware: detail of the interior of a decorated bowl . . . . .	146	131	Post-medieval red earthenwares: miscellaneous forms . . . . .	193
96-97	Colchester-type ware: large bowls or pancheons . . . . .	147-148	132	Post-medieval red earthenwares: dishes with decorated rims . . . . .	195
98	Colchester-type ware: handled bowls and miscellaneous bowls . . . . .	149	133	Post-medieval red earthenwares: dishes . . . . .	196
99	Colchester-type ware: cups and drinking vessels . . . . .	151	134-135	Post-medieval red earthenwares: large bowls or pancheons . . . . .	197-198
100	Colchester-type ware: chafing dish with anthropomorphic handles . . . . .	152	136	Post-medieval red earthenwares: large bowls or pancheons and medium bowls . . . . .	199
101	Colchester-type ware: anthropomorphic handles from chafing dishes . . . . .	152	137	Post-medieval red earthenwares: medium and small bowls . . . . .	200
102	Colchester-type ware: chafing dishes . . . . .	153	138	Post-medieval red earthenwares: small bowls, shallow bowls or dishes, and carinated bowls . . . . .	201
103	Colchester-type ware: strainers, ?curfew, firepot, water-sprinkler, bottles and bottles or costrels . . . . .	155	139	Post-medieval red earthenwares: bowls, porringers and cisterns . . . . .	202
104	Colchester-type ware: lids and dripping pans . . . . .	157			
105	Colchester-type ware: dripping pans, mortar, industrial vessels, ?candle-maker's troughs, and inkwells . . . . .	158			
106-107	Colchester-type ware: louvers . . . . .	160-161			
108	Colchester-type ware: roof furniture . . . . .	162			

140	Post-medieval red earthenwares: large storage jars . . . . .	204
141	Post-medieval red earthenwares: large and smaller storage jars . . . . .	205
142	Post-medieval red earthenwares: smaller storage jars and jars or chamberpots . . . . .	206
143	Post-medieval red earthenwares: chamberpots and tripod pipkins . . . . .	208
144	Post-medieval red earthenwares: tripod pipkins, tripod skillets and various jars . . . . .	209
145	Post-medieval red earthenwares: jugs . . . . .	211
146	Post-medieval red earthenwares: cups, mugs and tygs . . . . .	213
147	Post-medieval red earthenwares: miscellaneous forms . . . . .	214
148-9	Post-medieval red earthenwares: miscellaneous forms . . . . .	216-217
150	Pottery group from the Sheepen Civil War fort of 1648 . . . . .	218
151	Post-medieval red earthenwares: location plan of buried pots at Middleborough . . . . .	220
152	Three of the pots buried at Middleborough . . . . .	221
153	Metropolitan slipware: jug, small bowls or cups, tankard, dishes and bowl . . . . .	223
154	Metropolitan slipware: dishes and Dutch oven. . . . .	224
155	Border ware forms: bowls, dishes, skillets and tripod pipkin . . . . .	226
156	Border ware forms: miscellaneous . . . . .	227
157	Netherlands, Anglo-Netherlands and English tin-glazed earthenwares: bar chart showing percentages in stratified contexts . . . . .	229
158	Location of Lion Walk apothecary dumps and related topography . . . . .	231
159	Tin-glazed wares: drug jars . . . . .	233
160	Tin-glazed wares: simplified matrix of Lion Walk 'C' post-medieval pit complex . . . . .	235
161	Tin-glazed wares: Netherlandish, Anglo-Netherlands and English drug jars . . . . .	236
162	Anglo-Netherlands tin-glazed wares from Lion Walk: dishes or 'chargers' . . . . .	238
163	Anglo-Netherlands, Dutch and English tin-glazed wares: dishes, plates and saucer. . . . .	239
164a-f	Dutch tin-glazed wares: plates . . . . .	240-242
165	Tin-glazed wares: various forms . . . . .	243
166	Tin-glazed wares: the pharmaceutical inscriptions from drug jars . . . . .	244
167	North Devon gravel-tempered ware: bowl. . . . .	245
168	English stoneware: various forms . . . . .	246
169	Wrotham slipware: jug or jar sherd with applied decoration . . . . .	247
170	Staffordshire-type slipware: various forms . . . . .	248

**Chapter 6. English wares: modern**

171	Late slipped kitchenwares . . . . .	255
172	Sussex inlaid slipware: ?tobacco jar . . . . .	256

**Chapter 7. French wares**

173	Map showing the sources of medieval and post-medieval imported wares at Colchester . . . . .	259
174	French wares . . . . .	260
175	French wares. . . . .	263

**Chapter 8. Low Countries wares**

176	Brunssum-Schinveld ware . . . . .	265
177	Andenne ware: jar or pitcher base. . . . .	266
178	Low Countries red earthenwares: bar chart showing percentages in stratified contexts . . . . .	267
179	Low Countries red earthenwares: cauldrons and pipkins . . . . .	268
180	Low Countries red earthenwares: miscellaneous forms . . . . .	269
181	Low Countries red earthenwares: miscellaneous forms . . . . .	271
182	Low Countries red earthenwares: curfews . . . . .	272
183	North Holland slipware: bowls and curfew . . . . .	273
184	Low Countries white earthenwares . . . . .	274
185	South Netherlands <i>maiolica</i> . . . . .	275

**Chapter 9. German wares**

186	Paffrath-type ware . . . . .	276
187	Siegburg stoneware. . . . .	278
188	Langerwehe stoneware . . . . .	279
189	Gothic (Saxony) stoneware . . . . .	281
190	Raeren stoneware: bar chart showing percentages in stratified contexts . . . . .	282
191	Raeren stoneware . . . . .	283
192	Cologne and Frechen stonewares: bar chart showing percentages in stratified contexts . . . . .	284
193	Cologne and Frechen stonewares: mugs and jugs . . . . .	285
194	Cologne and Frechen stonewares: <i>Bartmann</i> jugs . . . . .	286
195	Cologne and Frechen stonewares: mugs and jugs . . . . .	287
196	Westerwald stoneware. . . . .	289
197	'Hessian' crucible . . . . .	290
198	German slipwares . . . . .	291

**Chapter 10. Iberian wares**

199	Iberian wares . . . . .	295
-----	-------------------------	-----

**Chapter 11. Italian wares**

200	Italian wares . . . . .	299
201	Italian oil jar . . . . .	302
202	Italian oil jars: stamps . . . . .	303
203	Italian oil jars: details of excavated sherds . . . . .	304

**Chapter 12. Far Eastern wares**

204	Martabani stoneware jar . . . . .	306
-----	-----------------------------------	-----

**Chapter 13. Miscellaneous unsourced ?imports**

205	(not used)	
206	Mediterranean 'mercury' jars . . . . .	307

**Chapter 14. The stratified groups**

207	Stratified Group 2 . . . . .	311
208	Simplified section through town ditch at Lion Walk . . . . .	312
209-213	Stratified Group 4 . . . . .	313-314, 315
214-215	Stratified Group 5 . . . . .	317-318
216-217	Stratified Group 6 . . . . .	319-320
218	Stratified Group 7 . . . . .	321
219	Stratified Group 8 . . . . .	323
220-221	Stratified Group 9 . . . . .	324-325
222-224	Stratified Group 10 . . . . .	326-328
225	Stratified Group 11 . . . . .	329
226-227	Stratified Group 13 . . . . .	330-331
228-229	Stratified Group 15 . . . . .	332-333
230-232	Stratified Group 17 . . . . .	335-337
233	Stratified Group 19 . . . . .	338
234-239	Stratified Group 20 . . . . .	339-344
240-244	Stratified Group 21 . . . . .	345-349

245-246	Stratified Group 22 . . . . .	350-351
247	Major local fabrics: bar chart showing percentages in stratified contexts . . . . .	352

**Appendix 3. Neutron activation analysis**

248	Plot of the first two discriminant analysis scores for six clusters of samples . . . . .	373
-----	---	-----

**Colour photographs**

Plate 1	Hedingham ware: late 12th- and 13th- century forms . . . . .	389
Plate 2	Colchester-type ware; group of early style white slipped jugs, c 1250-1350 . . . . .	389
Plate 3	Colchester-type ware: jug sherds with Rouen-style slip decoration (early style), c 1200-1250 . . . . .	390
Plate 4	Colchester-type ware: polychrome jug sherds copying Mill Green polychrome baluster jugs, c 1290-1325 . . . . .	390
Plate 5	Colchester-type ware: vessels with middle style slip-painted decoration, 1375-1450 . . . . .	391
Plate 6	Colchester-type ware: jug copying Saintonge <i>pégau</i> form with sgraffito 'merchant's mark', c 1375-1450 . . . . .	391

---

## Acknowledgements

---

Colchester Archaeological Trust acknowledges with gratitude the financial support of English Heritage in the publication of this volume. Smaller but no less welcome contributions have also been received from the British Museum and Colchester Museum.

Of the individuals connected with the preparation of this volume, the largest debt of thanks is owed to Carol Cunningham, former Director of Chelmsford Archaeological Trust, who was responsible for the inception of this study and who remained closely involved with the project during its early years. To her is due much of the credit for constructing the ceramic framework which forms the backbone of this study and she was closely involved with the analysis of some of the wares presented here — in particular the Middleborough kilns and Colchester-type ware.

Secondly, I would like to thank all the staff and volunteers of the Colchester Archaeological Trust, past and present, that were in any way connected with this project. Invaluable assistance was provided in particular by the Director Philip Crummy, by the finds specialist Nina Crummy, by the Roman pottery specialists Robin Symonds and Sue Wade, by computer technician Simon Garrod, and by Gillian Adams. The photographs were taken by Alison Colchester.

Thanks are due to the Manpower Services Commission for providing illustrators and assistants. The principal (MSC) illustrators were Raphael Nazroo, Alex Scott, and John Hepburn. Other drawings were done by the Trust's illustrators Robert Moyes and Terry Cook, and the remainder by John Callaghan, Simon and Fran Buxton, Sue Barnett (Canterbury Archaeological Trust), and the author. The Angel Yard louver was analysed and illustrated by Barbara Hurman, and the drawing of the king-shaped finial was taken from the late Gerald Dunning's unpublished survey of roof furniture now housed in the British Museum.

Day-to-day assistance was provided by Denise Young, Matthew Duckett and Alexandra Knowles-Green (all MSC).

A debt of gratitude is owed to a number of other Colchester establishments and individuals, principally to the staff of Colchester Museum for all their help in locating pots,

answering countless enquiries and making space and facilities available for study and illustration. I am particularly grateful to Paul Sealey for all his assistance, encouragement and hospitality.

Members of the Colchester Archaeological Group helped with the original washing and marking of countless thousands of potsherds and Dennis Tripp volunteered to enter the thousands of Colchester-type ware records on computer. The late Felix Erith (CAG) kindly showed me the location of the Ardleigh post-medieval kiln-site.

For help with documentary sources I am indebted to Richard Shackle of the Colchester Local Studies Library, to John Bensusan-Butt, Geoff Tan, Chris Thornton, Pat Ryan (Essex County Council), Dr A F J Brown, Dr Richard Britnell (University of Durham), and the staff of Colchester Public Records Office.

Particular thanks are due to Canterbury Archaeological Trust for releasing me to complete this study and for providing every facility needed to bring this task to completion (despite disruption caused to their own work schedules). Without their co-operation this report may never have been completed. Thanks are due to Canterbury staff members: Simon Pratt and Mark Duncan for computer work and producing the tables, to David Dobson for drawing the maps and plans, to Jane Elder for word-processing and to Tania Wilson for help with the concordance.

Thanks are also due to Sarah Jennings and Deborah Priddy (both of English Heritage) who arranged the funding of this report in its later stages and offered much useful criticism besides, and likewise to R G Thomson who acted as external referee.

Last but not least I would like to thank the dozens of pottery specialists from all over Britain and abroad who have seen and commented on the pottery from Colchester. Their individual comments are credited in the relevant chapters, but for repeated help and advice over the years I am particularly grateful to John Hurst, Alan Vince, David Gaimster, Beverly Nenck, Sarah Jennings, Michael Archer and Helen Walker.

*John Cotter,  
Canterbury 1997*

---

# Chapter 1. Introduction

---

## Aims of the report

The original aim of this report was to provide an account of the very large amount of post-Roman pottery produced by the Colchester excavations of 1971-85, and thus to complete the series of Colchester Archaeological Reports dealing with the excavations themselves and the various categories of finds recovered, such as the small finds, Roman pottery and glass, etc. This original aim, enshrined in the title of this report, remains at the centre of the work.

Implicit in this aim was the production — inasmuch as time and resources allowed — of an illustrated typology of pottery forms arranged by presumed source, date and fabric, together with a discussion on chronology supported by the illustration of stratified groups of pottery. From an economic point of view, it was — and still is — hoped that the report would serve as a reference work for future archaeologists excavating in the Colchester area, thereby diminishing the need for repeated illustration of the commoner forms of post-Roman pottery dealt with in this volume.

In the decade or so that this report has been in preparation, the original aims have been widened somewhat, while other originally peripheral aspects (eg documentary sources) have deepened. The need for a wider synthesis of Colchester's post-Roman pottery has become more apparent, and material outside the original 1971-85 excavation brief (eg museum material) has been added to the volume to fill gaps in the excavated assemblage. Documentary work on both published and unpublished sources has also allowed a deeper insight into the social and economic contexts in which the pottery was used and the community that used it.

In certain cases, material from Colchester has been used as a springboard for wider discussion of particular wares in Essex, East Anglia or even further afield. Here the purpose has been to draw attention to these wares and to stimulate future discussion. Thus the aim of the present report is now rather wider than that of the original. It aims to provide a synthesis of post-Roman pottery from the Colchester area, and to a lesser extent, a synthesis of certain categories of ware native to north Essex, and finally, in a few cases, a statement of our current knowledge of some minor wares occurring as imports at Colchester and elsewhere.

## The sites: general characteristics

[Fig 1]

This study is based on around two tonnes of post-Roman pottery from more than 80 sites and watching briefs in Colchester undertaken by the Colchester Archaeological Trust between 1971 and 1985. A few exceptional vessels from excavations up to 1989 are also included, together with

several dozen complete vessels recovered from various other findspots in the town (in the collection of Colchester Museum), plus a few vessels from elsewhere in north Essex.

Many of the sites are self-contained sub-sites within more extensive areas of excavation up to approximately four acres in extent. In terms of post-Roman pottery, the most important area excavations were those at Lion Walk, Culver Street and Middleborough (Fig 1), though some smaller sites also produced useful assemblages. The locations of the larger excavations, mainly in the southern intramural and the west and north-western extramural areas, were dictated by redevelopment which tends to occur in the commercial parts of town. By comparison, the relatively undeveloped northern and eastern areas of the walled town have escaped both large-scale redevelopment and consequent excavation.

Before listing the individual sites in more detail below, it will be useful to summarise the main characteristics of features on the 1971-85 excavations which produced post-Roman pottery. Detailed descriptions of these features and their interpretation may be found in other reports in this series (*CARs 1, 3, 6 and 9*).

Anglo-Saxon activity (5th to 7th century) is represented by three or perhaps four Anglo-Saxon sunken huts at Lion Walk and Culver Street, which have produced a small but significant collection of pottery. Definite late Anglo-Saxon features are extremely rare and confined to a few rubbish-pits probably of the early to mid 11th century on the Cups Hotel site in the High Street. Norman robber trenches and pits are particularly abundant and are the main source of the early medieval pottery recovered from the excavations.

In a town with no naturally occurring stone, the robbing of Roman foundations by means of digging trenches was a natural response to the demand for building materials. Extensive robbing of Roman ruins must have begun before 1066 as surviving late Saxon churches in Colchester already incorporate large quantities of Roman brick. At first, standing ruins must have been exploited, but as demand increased even the foundations of Roman buildings were robbed for the rubble. Most of the town's robber trenches are thought to date to the later 11th and 12th centuries, coinciding with the sudden enormous demand for building materials on ambitious Norman projects such as the castle, St John's Abbey, St Botolph's Priory and numerous parish churches (*CAR 1, 47-8*). A few robber trenches contain only 13th-century pottery, and one exceptional robber trench behind the town wall seems to have been dug as late as c 1400 (see Stratified Group 9).

Rubbish-pits or cess-pits were also abundant from the late 11th and particularly the 12th century, and some have produced particularly large and well-preserved groups of pottery (eg Stratified Groups 5 and 6). Right up until the 18th century, rubbish-pits continued to be the main repositories of discarded pottery. Only in the 13th to 14th centuries is there an apparent thinning-out in the frequency of pit-digging, a national trend thought to be related to plague-

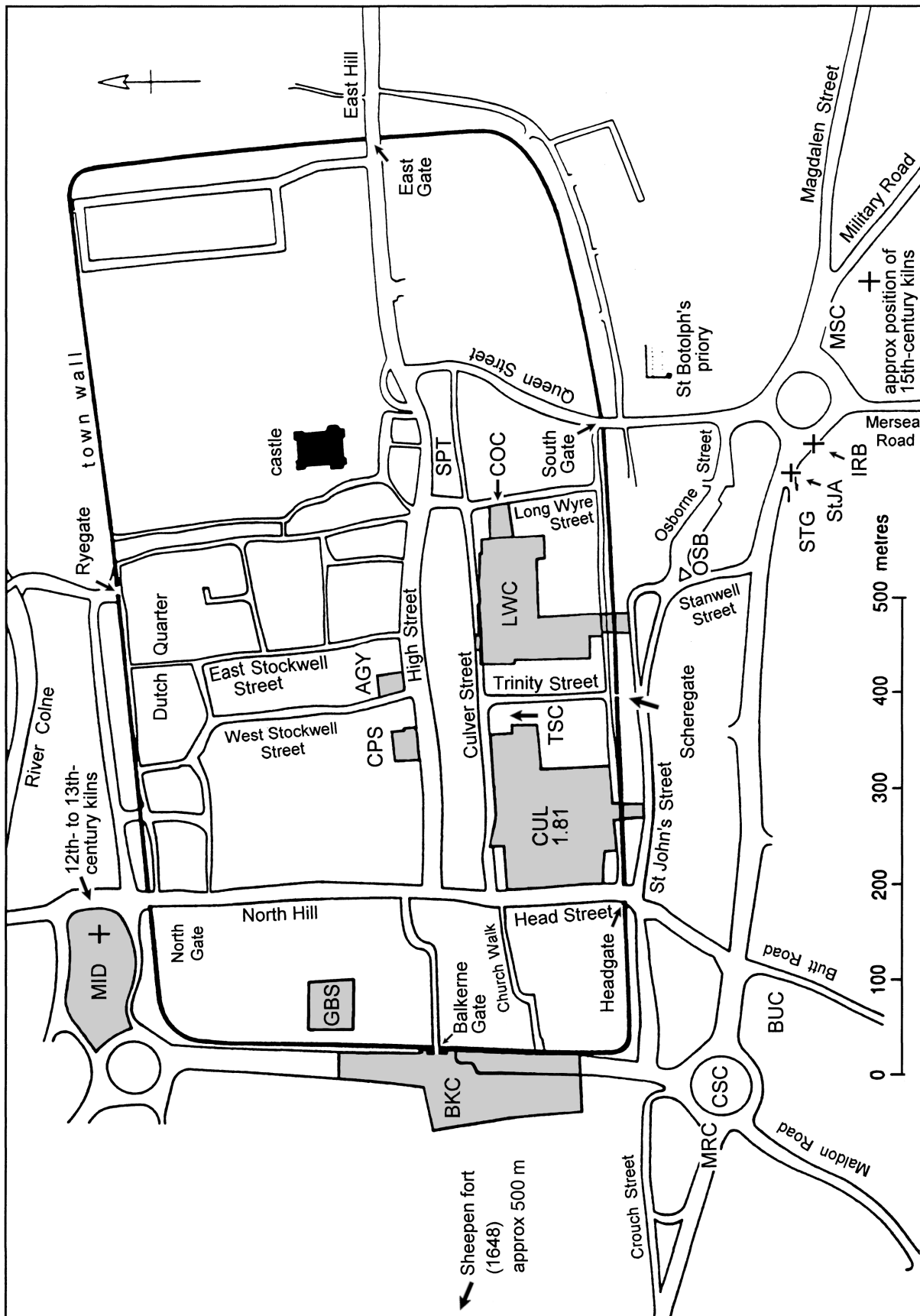

Fig 1 Location of sites of Colchester excavations which produced post-Roman pottery, 1971-85.



prevention measures (Platt 1976, 72). In the 15th and 16th centuries, stone-lined latrines were added to a number of Colchester houses, and these have also produced substantial groups of pottery (eg Stratified Group 13). Brick-lined latrines replaced these from the 17th century onwards.

At least a dozen medieval houses have been excavated. These are typically late medieval timber-framed structures standing on low walls or plinths of mortared tile, although a few earlier 'Norman' houses were built entirely in stone. Many of these medieval houses survived with alterations into the late post-medieval period. The remains of post-medieval houses, both timber-framed and brick-built, have also been excavated.

Military or defensive features excavated included the 11th-century town ditch at Lion Walk and a section through the adjacent Roman and medieval town wall. A much earlier excavation on one of the 1648 Civil War siege forts produced a small group of pottery which is also included in this report.

Industrial features include lime kilns, pottery kilns and a bronze-working oven (see below for details). There has been only limited excavation of medieval religious sites in Colchester and these have produced only very small assemblages of pottery. More recent excavations at St Botolph's Priory and St Mary Magdalen's church (a former leper hospital) have produced rather larger assemblages, but these lie outside the scope of the present report.

Pottery as evidence of trades, rather than purely domestic occupation, is almost certainly represented in the large dumps of post-medieval apothecaries' wares at Lion Walk (eg Groups 19 and 20), while at Middleborough, Lion Walk and perhaps other sites there is evidence of extensive rubbish-dumping from nearby inns or taverns (eg Stratified Group 21).

Apart from the pottery kilns and a few other instances, one can summarise the post-Roman archaeology and hence the pottery from the 1971-85 excavations as being overwhelmingly domestic in character.

## The site code reference system

This is basically the same as that described in *CAR 3* (pp 1-2). The earlier sites have an alphabetic code, eg LWC for Lion Walk, MID for Middleborough, and so on (see below). Some later sites have a museum accession code, eg 1.81 for Culver Street (unofficially CUL). Each sub-site within a larger site is referred to by an area code, eg LWC J, for Site J at Lion Walk. Each area is followed either by a feature number, eg F68, perhaps a pit or a trench etc, or by a layer number, eg L77, which could represent a spread of material or a layer within a pit. Where neither a feature nor a layer is concerned the finds number is given, eg B22 for finds number 22 from Site B. Finds numbers are the component parts of features or layers or else discrete contexts in themselves. Before 1973, finds numbers often equated with layers. Full site and context references therefore will usually appear in the following format:

LWC RF18: Feature 18 on Site R at Lion Walk  
 LWC KL101: Layer 101 on Site K at Lion Walk  
 LWC N3: Finds number 3 on area N at Lion Walk

The post-Roman pottery came predominantly from features, usually pits or trenches. The fills of these could be composed of several finds numbers which could represent layers within the features or else arbitrary spits.

To facilitate rapid recording for this report, pottery was catalogued by feature whenever possible. The bags of pottery from a single feature were assembled and examined to determine whether or not the finds numbers concerned represented fills of significantly different date or character within the context. Where no significant difference was detected, all the pottery from a single feature was merged and recorded and bagged by fabric. Apart from the element of time saving, this system had the advantage of allowing vessel profiles (often from several finds numbers) to be assembled quickly and selected for illustration.

## The sites: a gazetteer

### Lion Walk (LWC; *CAR 3*, 31-92, see also Fig 158)

The site lies in the southern intramural half of town, bounded by Culver Street to the north and the town wall to the south. The lane Lion Walk, running north-south, divides the site into eastern and western halves and continues northwards beyond Culver Street as a passageway through the Red Lion Hotel, a prominent, early Tudor building fronting onto the High Street.

The excavations revealed two large Roman courtyard houses and the eastern edge of the legionary fortress. Two Anglo-Saxon huts represent the earliest post-Roman features from the town (see below). A scatter of 10th- to 11th-century Thetford-type ware occurs across the site, and a concentration of this on Site J indicates some form of Late Anglo-Saxon activity in the area though no features of this date were identified. Pits and robber trenches of late 11th- to 12th-century date are prolific across the site, but the lack of features dug before c 1050/1100 is considered to reflect the distance the site lies away from the High Street, where occupation in the town was concentrated perhaps until the 12th century (*CAR 3*, 75). A concentration of tap slag in robber trenches and other features at the southern end of the site indicates 11th-/12th-century iron-working, but no associated industrial features were located (*CAR 3*, 91).

The most important medieval feature of the site was a 12th-century stone house (possibly two houses) at the northern end of the site (see below, Sites G and D). This remained an important feature throughout the medieval and post-medieval periods until its demolition in 1971, and had a significant influence on the nature of pottery assemblages in the immediate vicinity. The location of the house on the corner of Lion Walk and Culver Street demonstrates the existence of these two streets by the 12th century. Lion Walk is first recorded as a street c 1320 when it was known as Cat Lane (*CAR 1*, 79).

It is likely that much of the Lion Walk area was under cultivation in the medieval period. Convincing evidence for cultivation, perhaps in the 12th and 13th centuries, has been found at the southern end of the site (*CAR 3*, 92). Morant's 1748 map of Colchester shows only a few houses along the west frontage of Lion Walk, and behind these, the extensive ornamental gardens of Trinity House. The east

frontage remained as gardens and a timber yard until the building of Lion Walk Congregational Church at the southern end in 1765 (CAR 6, 381-4).

Details of land ownership in the area are unknown or un-researched for the medieval period. The builders of the stone house on the corner of Lion Walk are likely to have been fairly wealthy, possibly even members of the town's small Jewish community (CAR 1, 69), though there is no definite evidence for this. Later occupants of the house could have included wealthy artisans or merchants, and it is suggested that wealthy apothecaries may have owned the house in the late 16th and 17th centuries (see below, p 5). There is strong evidence that in the late 15th century both frontages of Lion Walk were owned by Lord John Howard, Duke of Norfolk and Constable of Colchester Castle. In 1481 or 1482, Howard built a hall at the northern end of Lion Walk street set back a little from the High Street (VCHE, 9, 44). After his death at the Battle of Bosworth in 1485, Howard's Colchester properties passed to his son Thomas, second Duke of Norfolk and Earl of Surrey. The original hall became the nucleus of an impressive timber-framed inn containing shop units. This 'New Inne', otherwise 'Le Whyght Lyon', was eventually called the 'Red Lion Inn'. Two documents of 1515 establish that the Earl of Surrey (Duke of Norfolk) was the owner and that considerable gardens and farms were annexed to the inn, some of which lay to the south (Stenning 1994, 155-6). David Stenning identified these gardens as the east frontage of Lion Walk (*ibid*, fig 1), but it is likely that the west frontage was also included. These gardens remained the property of the Red Lion Inn until the 18th century. David Stenning tentatively identifies the north-east frontage of Lion Walk as a piece of vacant land called 'Le Stalles' in a will of 1573 (*ibid*).

The excavations demonstrated that extensive late medieval or post-medieval pit-digging took place in the 'gardens' of the 'Red Lion Inn'. Much of the pottery and other finds recovered here is likely to represent rubbish from the inn itself and from the shop units on the High Street. It is known that the inn was owned by wealthy apothecaries, perhaps from the late 16th century until the 18th century, and that their shop occupied one of the High Street units. There can be little doubt too that the large numbers of tin-glazed apothecary jars recovered from Lion Walk also represent rubbish-dumping from this source (Chapter 5, pp 230-2).

The Red Lion was one of at least seven medieval inns in the market area of the High Street and it was abutted in 1515 by two other inns (Stenning 1994), which all probably disposed of their rubbish to the rear on the south side of Culver Street, in and around Lion Walk. Definite evidence of tavern waste is not easily distinguished from the mass of domestic rubbish but probably includes a 15th- or 16th-century brass spigot tap (CAR 5, fig 44) from Site B (east frontage).

By the end of the 19th century, most of the Lion Walk area had been built over by housing, almshouses and the rebuilt Congregational Church.

The sub-sites at Lion Walk are listed below (see CAR 3, fig 59 for general plan and figs 60 and 61, sheets 2a and 2b for detailed plans).

## 1) East frontage sites

### Sites A and R (LWC A and R)

These are adjoining and the most easterly LWC sites, lying approximately 45 m east of Lion Walk. Pits, robber trenches and lime kilns. The pottery is almost entirely post-medieval, but with a very large assemblage of 17th- to 18th-century wares including several tin-glazed 'chargers' from rubbish-pits LWC AF3 and AF6. Many complete profiles from these pits are illustrated in this report. A north-south robber trench or soakaway on Site R produced Stratified Group 22, c 1730-40 (LWC RF18). A large collection of Anglo-Saxon antler-working debris from LWC RF15 was accompanied by a single sherd of Anglo-Saxon pottery (CAR 5, 88-91).

On Morant's map of 1748, this area is shown as a large orchard or garden to the rear of houses set back a little from Culver Street. It probably lay beyond the area of Lion Walk owned by the Red Lion Inn (possibly on its eastern boundary). This fact appears to be expressed in the low numbers of pharmaceutical vessels from Sites A and R in contrast to sites further west. However, fragments of several glass alembics (distilling vessels) were recovered from one early 16th-century pit (LWC AF15), suggesting the presence of apothecaries (see p 232).

### Sites B and S (LWC B and S)

These are adjoining sites on the east frontage, with early medieval robber trenches, and medieval and post-medieval pits and trenches. The pottery is mostly post-medieval. The robber trenches include an unusually late, 13th-century example (LWC BF18) dated by a Paffrath-type ladle (Fabric 18), a North French green-glazed jug (Fabric 27), and local wares. There are 14th- and 15th-century rubbish-pits including Stratified Group 11, c 1425-75 or earlier (LWC BF45). A large north-south trench (LWC BF14) is interpreted as a boundary ditch, possibly shown on Morant's map of 1748. This feature produced a large collection of tin-glazed apothecary or pharmaceutical wares deposited c 1650 (Stratified Group 20), possibly discarded at the death of a prominent local apothecary in 1655 (see Chapter 5, p 232 and Stratified Groups 19 and 20).

### Site U (LWC U)

This is a very small site, east frontage, with medieval and later pits and trenches.

### Site V (LWC V)

Dispersed watching-brief. The most significant post-Roman feature was a large pit on the north-east frontage of Lion Walk which yielded Stratified Group 19 of c 1650 (LWC VF2). Like Stratified Group 20, approximately 40 m south, this pit produced an important collection of tin-glazed apothecary wares and a German crucible containing droplets of mercury. Nearby, a brick-lined latrine (LWC VF1) produced a range of pottery and clay pipes dating from c 1740 to 1840, including eight chamberpots in local and imported fabrics.

## 2) West frontage sites

All the sites listed below lie on the west frontage of Lion Walk except Sites M and N which lie adjacent to the town

wall, south of Eld Lane. Sites are listed roughly from north to south. Any changes to the excavator's original site or building phases (as listed in *CAR 5*, 4-5) are indicated where necessary.

#### Site G (LWC G)

This site occupies the north-west corner of the frontage at the junction of Lion Walk and Culver Street. The archaeology is dominated by Building 28, a Norman stone building which survived through many structural additions and alterations until its demolition in 1971 (*CAR 1*, 53-4; *CAR 3*, 75-82).

The revised site periods presented below are based on a careful study of the stratigraphic evidence in combination with architectural, numismatic and ceramic dating evidence. The original site periods have been refined and subdivided but not radically changed.

Period 1a	c 1100-1125	Pits and robber trenches
Period 1b	c 1125-1150	Pits and robber trenches
Period 2a	c 1150-1200	Building 28, Phase 1
Period 2b	c 1180-1350	Building 28, Phase 1
Period 2c	c 1350-1500	Building 28, Phase 1
Period 3	c 1500-1600	Building 28, Phase 2
Period 4a	c 1600-1680/1700	Building 28, Phase 3
Period 4b	c 1680/1700-1720	Building 28, Phase 3
Period 4c	c 1720-1972	Building 28, Phase 3

Some of the main dating evidence from the site may be summarised here as it affects the dating of a number of pottery fabrics discussed elsewhere in this report. Two episodes of robber trench- and pit-digging can be distinguished before both were cut by the foundation trenches for Building 28. The robber trenches of Period 1a produced two Norman coins: a cut halfpenny of William I from F233, struck c 1066-87 and probably lost by c 1095 (*CAR 4*, 65), while a penny of Henry I from F203 was struck c 1105 and probably lost by c 1115 (*ibid*). These contexts produced early medieval sandy ware (Fabric 13) together with Stamford and developed St Neots-type wares, a few possibly residual sherds of Thetford-type ware and a residual sherd of 10th-/11th-century North French glazed ware (Fabric 95P). The high percentage of imported regional wares in these contexts together with the two Norman coins suggests dumping from a fairly affluent source, possibly from buildings along the High Street.

Building 28 sealed these earlier pits and robber trenches. It was constructed of coursed rubble and probably took the form of a first-floor hall. A round-headed opening in the Phase 1 wall could date as late as c 1200 but could, on the evidence presented above, date anywhere between c 1115 and 1200. The excavator has suggested a date of c 1150 as a suitable estimate for the first phase of the building (*CAR 3*, 75).

In subsequent phases, new rooms and other adaptations were made to Building 28, the details of which are described in *CAR 3* and need not concern us here. Late in Phase 2, a chequerboard floor of Flemish tiles was laid in Room 3b. This has been dated to the 15th or 16th century, and it was repaired in places with local unglazed pavement tile of the mid 16th century or later (*CAR 3*, 81). Sherds of Cologne/Frechen stoneware (Fabric 45D/E) and a sherd of local Fabric 40 sealed by the floor suggest it was laid after c 1525 and had probably been abandoned as a room by c 1625, when extensive pit-digging occurred.

The quality of late medieval and post-medieval pottery from Site G (and adjoining Site E) reflects to a degree the status of its occupants at this time. The yard of Building 28 produced sherds of at least two Saintonge polychrome jugs (c 1275-1325), which are generally rare in Colchester. The south yard produced a sherd from a very rare German 'Gothic' stoneware drinking vessel (Fabric 45K; probably 15th century), the only example of its kind in Britain. Another luxury ceramic — a sherd of Sevillian *Cuerda Seca* (Fabric 46D/1) — was found in Room 8. A complex of large rubbish-pits was dug through the floors of Rooms 6 and 7 during the early 17th century, and these produced some substantial groups of pottery, among them numerous fragments of fine 16th- and 17th-century German stone-ware and slipwares, several Nuremberg tokens and Italian *maiolica*. One of these pits produced Stratified Group 18 (LWC GF24, c 1625-50).

There is no definite evidence available as to the identity of the builders or occupiers of Building 28, but there is little doubt that they must originally have been persons of some wealth to have owned a stone house in a town where stone was scarce and most buildings were of wood and daub. To what extent Colchester's stone houses can be connected with the small but wealthy Jewish community, present from c 1180 onwards, is unclear. It is certain, however, that in the 13th century Jews did own a number of stone houses in and near the High Street, so it is possible that Building 28 might also have once belonged to Jews (*CAR 1*, 69; Stephenson 1984-5, 50).

In the later medieval period, one would expect a house of this sort to have been occupied by fairly prosperous merchants or artisans. In the late 15th century or perhaps the early 16th century, the house, like much of Lion Walk, could have been part of the estate of the Duke of Norfolk together with the Red Lion Inn (*see above*), with both perhaps leased to tenants. There is circumstantial documentary evidence to suggest that, in the late 16th and 17th century, Building 28 may have been the home of the Buxton family — wealthy and influential apothecaries — who owned the Red Lion Inn and much of the Lion Walk frontage until 1655 (*see Chapter 5*, p 230). The later ownership of Building 28 is similarly unresearched.

#### Site D (LWC D)

The site is a westerly continuation of Site G along the south frontage of Culver Street. The eastern half of the site is occupied by the northernmost room of the stone Building 28 (mainly Site G, *see above*) and is phased as Site G. A north-south foundation was probably a party wall between Building 28 and Building 29 — apparently a timber-framed building later largely replaced in brick (*CAR 3*, 82). The pre-building period of Site D is similar to that on Site G, with pits and robber trenches containing an assemblage of pottery dating to c 1150-1200 and including sherds of Stamford and Andenne wares and glazed Hedingham ware.

The Phase 1 gravel floor of Building 29 sealed a sherd from a Hedingham stamped strip jug (G253) and sherds of early Colchester-type ware, giving a rough date of c 1250 for the start of Building 29. The following building phases are assigned by the excavator.

Phase 1:	c 13th/14th to 16th/17th centuries
Phase 2:	c 16th/17th century to c 1650-1700
Phase 3:	c 1650-1700 to 1972

There is less pottery and a more disconnected stratigraphy

than on Site G. There are some cross-joins between pottery from both sites in Phase 1, and a sherd from a 13th-century London-type ware *aquamanile* on Site D could indicate occupants of moderately wealthy status. Like Site G there is a fairly large collection of imported German stonewares in the 15th- to 17th-century levels. Both sites produced substantial parts of 15th- to 16th-century industrial vessels in Colchester-type ware (Figs 92.132 & 105.239), possibly connected with distilling or alchemical practices.

#### Site E (LWC E)

This site has some early medieval pits but mostly 15th-/16th-century pits probably representing dumping from Buildings 28 and 29 (above). Room 8, a 16th-century extension of Building 28, encroached on the site. Part of Building 30 (Trinity House), a brick building of the 18th to 20th centuries, encroached on the northern side of the site (CAR 3, 82).

#### Site H (LWC H)

An Anglo-Saxon sunken hut (Hut 2) produced Stratified Group 1 (5th century, see CAR 1, 5-6). The site also included early medieval to post-medieval pits.

#### Site J (LWC J)

On this site, early medieval pits and robber trenches yielded a higher than normal concentration of late Saxon Thetford-type ware. A medieval lime kiln contained 13th-century pottery. The site also included 16th- and 17th-century pits.

#### Site P (LWC P)

This site had early medieval pits and robber trenches, excavated by sample trenches only. The pottery has not been catalogued.

#### Site K (LWC K)

An Anglo-Saxon sunken hut (Hut 1) was dated to the 6th/7th century (CAR 1, 1-5). The site also included early medieval and later pits and trenches. Some large late 15th- to 16th-century rubbish-pits included F64, c 1525-50, possibly an early apothecary's dump (see Chapter 5, p 232). There was also an important apothecary's dump of c 1600 (F15) containing complete German stoneware vessels and tin-glazed Netherlands drug jars (p 232).

#### Site T (LWC T)

This site had early medieval pits and trenches. It was a very small site; the post-Roman features were not excavated.

#### Site Q (LWC Q)

Late 15th- to 17th-century pits, mostly unexcavated.

#### Site C (LWC C)

Early medieval pits and robber trenches. Complex of late medieval and post-medieval rubbish-pits including Stratified Groups 12 (LWC CF65; c 1475-1525) and 16 (LWC CF77/F22; c 1550-1600). Large number of tin-glazed drug jars probably indicating apothecary's dump (see Chapter 5, pp 235-43).

#### Site L (LWC L)

Early medieval pits and robber trenches cut by a complex of at least nine medieval lime kilns with five phases (CAR 3, 87-91). Although these have been described as being of 'later type', re-examination of the pottery associated with the kilns suggests Phase 1 began in the 13th century and Phase 5 probably ended in the 14th century, although the pottery could be a little residual.

The kilns were succeeded by a phase of pit-digging in the 15th century. This includes Stratified Group 10 (LWC LF33; c 1400-50), a large rectangular daub-lined pit that may have had an industrial function.

These features are in turn cut by pits containing 15th-/16th-century stoneware. Finally most of the site was sealed by Building 31, a group of almshouses built in the reign of Charles I and which fronted onto Eld Lane. They were rebuilt in 1897 (Building 32; CAR 3, 82).

#### Site M (LWC M)

Section across rampart behind town wall. Large robber trench for rear face of Roman town wall apparently an official undertaking connected with the refurbishment of the wall c 1382-1421. Produced Stratified Group 9 of this date (LWC MF22/F52/F53; see Fig 208). Other late and post-medieval pits.

#### Site N (LWC N)

Section through Roman and medieval town wall including medieval bastion (c 1382-1421) which was demolished after the siege of 1648. A section through late Saxon defensive ditch produced a sequence of deposits from c 1050-1300 (Stratified Group 4; LWC NF21, see Fig 208). Fifteenth- to 16th-century pits and foundations of house of same date, possibly destroyed in siege of 1648 (Building 33; CAR 3, 84).

#### Culver Street (1.81 or CUL; CAR 6, 21-205)

The Culver Street site lies to the west of Lion Walk, and also inside the town wall. The development covers about four acres and is the largest archaeological site ever dug in the town. Much of this large area was periodically under cultivation during the post-Roman period. Evidence for the accumulation of 'dark earth' (cultivation soil) was found on many of the sub-sites even as late as the post-medieval period (CAR 6, 122), and the site lies close to the south-western angle of the town wall where seasonal crops were grown in the 14th century (Britnell 1986, 10). Speed's map of 1610 and Morant's map of 1748 show the Culver Street area to have been largely composed of orchards, gardens and fields with relatively few houses along the Culver Street and Head Street frontages. These factors probably explain the relative lack of post-medieval pottery from the site, in marked contrast to Lion Walk where no site lay too far from a street frontage or a building. Shewell Road, which bisects the site at Culver Street, is of recent origin.

From the ceramic viewpoint, there are two chronological peaks at Culver Street, the 12th century and the 15th/early 16th century. The earlier material is heavily concentrated in the south of the site (Sites G and H), where it occurs in pits and robber trenches in the vicinity of a large wooden structure probably of early medieval date (Building 128). The considerable quantities of early medieval pottery recovered from these sites probably represents dumping to

the rear of houses on Head Street, though some of it may be associated with Building 128.

The 15th-/early 16th-century material is concentrated in the north of the site and probably represents dumping from houses on the south and perhaps the north frontage of Culver Street. Nearly all the pottery comes from large pits, some of which may be gravel pits while others may have been horticultural in origin before final use as rubbish-pits. The largest groups of 15th-/early 16th-century pottery came from the northernmost sites (Sites A, B and E), which also yielded three 15th-century coins. Large bowls, cisterns (for brewing) and drinking vessels predominate. Some of this could be ordinary domestic refuse, but the high number of vessels associated with drinking is suggestive of nearby inns. One pit on Site E (Stratified Group 14, 1.81 EF14/F19) produced a ceramic industrial base (Fig 105.238) and a piece of glass alembic, perhaps from the same distilling unit (Rachel Tyson, pers comm). A piece of glass flask or urinal came from the same context. All these are suggestive of apothecaries or the commercial distilling for liquor.

Besides the period/area concentrations outlined above, pottery of all dates between the 10th and 19th centuries occurs sporadically across the whole Culver Street site. Two instances of widely separated cross-joining sherds on Culver Street are worthy of note. The first of these concerns a distinctive Hedingham ware early rounded jug (Fig 49.1), of which most of the body and rim came from a pit on Site G (1.81 GF163; Stratified Group 6, c 1175-1200), while the handle was found over 50 m north-east in a contemporary layer on Site D (1.81 DL866). In the second instance, a rim sherd from a 17th-/18th-century mug in post-medieval redware (Fabric 40) was found on Site M (1.81 MF121) over 60 m north-east of the rest of the vessel on Site H (1.81 HF628). It is difficult to imagine the reasons for such a wide dispersal of the sherds from a single vessel. Perhaps the explanation is ploughing or the carting-away of topsoil or manure. One wonders how many other such instances have gone unrecognised.

Detailed descriptions of the sub-sites and post-Roman features at Culver Street have been published in *CAR 6* (overview pp 34-5, figs 3-9; detailed account pp 118-26). The following list will therefore be confined to the main pottery-producing features and the more significant post-Roman structures. Post-Roman pottery at Culver Street was almost entirely derived from isolated pits and robber trenches. Unlike Lion Walk with its substantial medieval/post-medieval buildings and sequences of lime kilns, Culver Street produced very few good sequences of post-Roman stratigraphy and hence cannot be phased in the same way. Sites A, B, C, D, E and M lie on the northern half of the site and J, G, H and K in the southern half. Site W was a watching brief along the west of the site behind the east frontage of Head Street (general site plan *CAR 6*, fig 1.2).

#### Site A (1.81 A)

Early medieval robber trenches. Numerous 15th-/16th-century rubbish-pits. Some later features.

#### Site B (1.81 B)

Anglo-Saxon sunken hut (Hut 3) yielding Stratified Group 2 (1.81 BF4, 7th century). Early medieval robber trenches, ?13th-/14th-century lime kilns. Large 15th-/16th-century rubbish-pits. Some later features.

#### Site C (1.81 C)

Very small site. Early medieval robber trenches. Some later pits. High proportion of Anglo-Saxon pottery probably derived from Site B.

#### Site D (1.81 D)

Early medieval robber trenches. Medieval and 15th- to 17th-century pits.

#### Site E (1.81 E)

Ambiguous ?Anglo-Saxon sunken hut (Hut 4; *CAR 6*, 120-22) or 12th-century timber-revetted storage pit producing a sherd of Anglo-Saxon vegetable-tempered ware (Fabric 1). Early medieval robber trenches and pits. Two c 13th-century ovens. Numerous 15th- to 17th-century rubbish-pits and latrines including Stratified Group 14 (1.81 EF14/F19, c 1525).

#### Site M (1.81 M)

Small site. Early medieval robber trenches and 15th- to 17th-century pits.

#### Site J (1.81 J)

Early medieval robber trenches and pits. Twelfth- or 13th-century oven. Several 15th-/16th-century pits. Some later features. Part of Building 128 (*see below*).

#### Site G (1.81 G)

Early medieval robber trenches and complex of large 12th- to early 13th-century rubbish-pits producing large amounts of pottery. These include Stratified Group 6 (1.81 GF163, c 1175-1200), identified on the basis of environmental evidence as a cess-pit (*CAR 6*, 124-5). In the northern part of Site G and extending into Site J, two east-west lines of pits have been interpreted as the footings of an early medieval building (Building 128; *CAR 6*, 122-3). Some 15th-/16th-century and later pits.

#### Site H (1.81 H)

Early medieval robber trenches, numerous 12th-century rubbish- and cess-pits including Stratified Group 5 (1.81 HF365, c 1125-50). In the south of the site was a group of probably three separate outbuildings of coursed rubble and peg-tile. These are referred to as Building 129 and probably represent ancillary structures of 15th- to 16th-century date in the garden of one of the houses on Head Street (*CAR 6*, 125). The main structure was a small cellar and adjoining rectangular pit for access by wooden stairs. These features produced Stratified Group 15 (1.81 HF39/F158, c 1525-50). Large amounts of 15th-/early 16th-century pottery were also recovered from the topsoil during site clearance. Some later features also excavated.

#### Site K (1.81 K)

This small site produced very few post-Roman features and only a relatively small amount of pottery. Much of this, however, was Anglo-Saxon and represented substantial parts of two or three 6th- to 7th-century vessels. Curiously these were found in a brick-built structure identified as a late

Roman ?corn-drying oven (CAR 6, 108-112; and see Fabric 1). The site produced a small collection of later pottery.

*Site W* (1.81 W)

Watching brief along west of site behind Head Street frontage. Medieval stone cellar (Building 130) but no associated pottery. A small collection of late medieval and post-medieval pottery was recovered, mostly unstratified. An unusual c 14th-century sgraffito-decorated tile from this site has been published (CAR 6, 260-61).

**Middleborough** (MID; CAR 3, 155-209)

Middleborough is a suburb on the north side of the town lying between the north-west corner of the town wall and the River Colne. A mill was located on the Colne, north of the excavated area, from at least c 1300 (Britnell 1986, 23). At least seven pottery kilns of c 1175-1225 were excavated here, and medieval and post-medieval animal bone from the site indicates that a tanning industry was located here (CAR 12, 51). The discovery of eight leaden cloth seals of late 16th- or 17th-century date, including an unused example, suggests that cloth-working or sealing may have taken place in the immediate locality (CAR 5, 35). Speed's map of 1610 and Morant's map of 1748 show houses along the southern and eastern frontages of the excavated area with fields or gardens to the rear (CAR 3, fig 191).

Four adult inhumations on the site, which were thought to be of probable late Saxon date, have been redated as Roman (CAR 6, 323). The earliest definite post-Roman features are robber trenches of the late 11th or early 12th century, though these produced very little pottery. The latest robber trenches date to the 13th or early 14th century; some of them cut the kilns of c 1175-1225.

A timber structure (Building 74) was associated with the pottery kilns and may have been a potter's workshop. Building 74 and the most easterly pottery kiln were in turn sealed by a timber-framed building (Building 75) for which pottery and numismatic evidence indicate a construction date of perhaps c 1300-1325.

Building 75 and its northern neighbour Building 76 occupied the eastern frontage of the site on Middleborough proper. Both were timber-framed buildings set on plinths of rubble and tile. Building 75 survived until c 1862 when a new cattle market was created on the site. A substantial part of Building 76 survived as the New Market Tavern until the site was redeveloped in 1978.

The post-Roman pottery is mainly derived from the early medieval kilns, from medieval and post-medieval occupation associated with Buildings 75 and 76, and from very extensive post-medieval rubbish-pits to the rear of these buildings and to the rear of (unexcavated) post-medieval houses along the southern frontage demolished in c 1862 (CAR 3, fig 190).

Middleborough was excavated as a series of sub-sites A, B, C, D, E and G, but a universal context numbering system was used for the site as a whole. Only Sites A, B, C and E are of relevance to the post-Roman pottery. Sites C and E correspond with Buildings 75 and 76 respectively. The early medieval kilns occur on Sites A and C (for convenience recorded as MID X). Sites A and B consist largely of post-medieval pits (for convenience recorded as MID Y).

Only one stratified group was selected for full publication, Stratified Group 21 (MID AF15, c 1680-1700). This produced over 100 clay tobacco-pipe bowls and may well have been a tavern dump. The pottery indicates that the occupants of the buildings were reasonably prosperous. Not unnaturally, most pottery from Middleborough is of local origin, supplemented in the period c 1270-1350 by Mill Green and Hedingham ware jugs from central and northern Essex respectively. Imports include a few Saintonge jugs (at least one polychrome) and, in the 14th and 15th centuries, two Spanish lustreware vessels. German stonewares are common from 15th- to 18th-century contexts along with German slipwares in the 16th to 17th century, a Mediterranean 'mercury' jar, an Italian Montelupo *tazza* and many Dutch slipware and coarseware vessels.

As unusual feature of the Middleborough buildings was the practice of burying whole pots under rooms with their rims set flush with the floor. In Building 76, a jug of c 1400 was set in the floor in before a hearth (Fig 73.15; CAR 3, fig 185), while in Building 75 six pots of c 1650-1700 were buried in various parts of the house (Fig 151, pp 219-21).

The phasing given here for MID C and E differs slightly from that given in earlier reports in this series (CAR 3, 189-208; CAR 5, 4).

*Site C* (MID C)

Period 1	c 1175-1225	Pottery kilns and Building 74
Period 2	c 1200/25-1270/1300	Robber trenches
Period 3	c 1270/1300-1325/50	Building 75, Phase 1a
Period 4	c 1325/50-1375	Building 75, Phase 1b
Period 5	c 1375-1450/1500	Building 75, Phase 2
Period 6	c 1450/1500-1580	Building 75, Phase 3
Period 7	c 1580-1770	Building 75, Phase 4a
Period 8	c 1770-1862	Building 75, Phase 4b
Period 9	c 1862-1978	Open livestock market

*Site E* (MID E)

Period 1	c 1150/1200-1270	Robber trenches
Period 2	c 1270/1300-1350	Building 76, Phase 1
Period 3	c 1350-1450/1500	Building 76, Phase 2
Period 4	c 1450/1500-1600	Building 76, Phase 3
Period 5	c 1600-1650	Building 76, Phase 4
Periods 6-7	c 1650-1862	Building 76, Phases 5 and 6
Period 8	c 1862-1978	Building 76 (New Market Tavern)

**Long Wyre Street** (COC; CAR 6, 355-65)

The site lies at the northern end of Long Wyre Street on the west frontage (nos 7-15) and occupies about a third of an acre. Redevelopment of the eastern side of the site in the 19th and 20th centuries resulted in the destruction of almost all traces of medieval occupation along the frontage, leaving little more than a succession of floors and foundations to the rear. These represent wings or out-houses added to the rear of houses during the medieval and post-medieval periods. The site phasing is presented below but, as fully considered pottery dates were not available at the time of phasing, the excavator's dates are in some cases rather too late. Periods 8 and 9 in particular could be up to a century earlier than the dates given here.

Periods 1-6	Roman	
Period 7	c 11th-c 14th century	Pits and robber trenches
Period 8	?c 14th/15th century	Building 149
Period 9	?c 16th century	Building 150
Period 10	?c 17th/18th century	Building 151
Period 11	c 19th/20th century	Modern buildings

Activity on the site commenced with the digging of robber trenches in the late 11th or more likely the 12th century. These trenches, and the site as a whole, produced quite a high concentration of late Saxon Thetford-type ware but all of this seems to be residual. An episode of pit-digging succeeded the trenches, probably in the 13th century. The pits were probably cess-pits relating to buildings on the street frontage. One of these pits produced Stratified Group 7 (COC F213, c 1225-75).

A layer of cultivated soil sealed both trenches and pits. In this soil were sherds of polychrome Colchester-type ware copying Mill Green ware and therefore datable to c 1300-1325.

In Period 8, the cultivated soil was cut by stakeholes representing Building 149. An oven and some cess-pits, some lined with stone, peg-tile and brick, are associated with this phase. The lined pits may represent 15th- or 16th-century structures, but the pottery is of the 13th, 14th and possibly early 15th centuries. One (unlined) cess-pit produced Stratified Group 8 (COC F212, c 1300-1325).

Building 150 (Phase 9) was a rear wing whose walls survived only as shallow robber trenches. Surviving features included ovens, drains and large cess-pits, some stone- or timber-lined. Associated pottery suggests a 14th- to early 15th-century date, and a coin of 1279-1350 reinforces this impression. An (unlined) cess-pit (COC F121) produced several almost complete vessels including a Saintonge *pégau* (Fig 174.7), a Dutch pipkin (Fig 179.4), and local wares of c 1400-1425.

In Period 10, a timber-framed building on low mortared plinths was constructed (Building 151). To the rear of this, a large pit produced Stratified Group 17 (COC F61, c 1625-50). Substantial groups of post-medieval pottery were associated with this phase and with the successive brick buildings of Phase 11.

### The Cups Hotel (CPS; CAR 6, 328-38)

A small but intensively-occupied site on the north side of the High Street. It lies next to the town hall, formerly the site of the Norman Moot Hall, which was the political heart of the medieval town. Most of the medieval frontage had been removed by post-medieval cellars. Consequently the main excavation trench was located 8 m further north, and a smaller trench a little north of this.

The following site phasing is slightly more subdivided than that published in CAR 6.

Periods 1-4	Roman	
Period 5	c 1000-1200	Pits
Period 5a	c 1100-1150	Robber trenches
Period 6a	c 1200	Layers
Period 6b	c 1200-1450	Buildings 155 and 157
Period 7	c 1450-1700	Buildings 156 and 157
Period 8	c 1700-1972	The Cups Hotel

Several sherds of early to mid-Saxon pottery were recovered from the main trench, and a stamped sherd of 6th-century or later date was found in a late Saxon context (Fabric 1; CAR 1, fig 21.1). A rim in Ipswich ware (c 725-850), the only definite example from the town, was found in a Norman robber trench (Fig 7.1; CPS F116), while another mid-Saxon sherd, either an Ipswich variant or a Frankish import, came from another late Saxon or Norman pit (Fig 8.1; CPS F46).

The earliest definite post-Roman features are a small number of large late Saxon pits, probably cess-pits, which include Stratified Group 3 (CPS F106, c 1000-1050). There are other pits of late 11th- and 12th-century date, while most of the robber trenches, some of which were exceptionally deep, seem to date to the 12th century. There is a high proportion of late Saxon Thetford-type ware from the site, most of it residual. Sherds of Stamford, St Neots-type and imported Andenne wares also occur in the robber trenches. A selection of early medieval sandy ware (Fabric 13) and Thetford-type vessels has been published, together with a discussion of the pits and robber trenches they came from (CAR 1, 34, figs 32-4).

Traces of the rear wall were found of a c 13th-century building which had probably fronted the High Street (Building 155). In the northern trench, the remains of a substantial stone building were found (Building 157), possibly early medieval or else c 13th century. Associated with this was a late medieval stone latrine producing a range of late medieval and post-medieval pottery. Both structures were probably demolished in the 19th century. The remains of a c 15th-century timber-framed building (Building 156) were found in the main trench. This fronted the High Street and may have been the original Falcon inn. This was mentioned from 1411 onwards, and was succeeded in the 18th century by the Cups Hotel, which was demolished in 1972 (CAR 6, 336-8).

### Balkerne Lane (BKC; CAR 3, 93-154)

The site lies along the western side of the town, outside and alongside the town wall. Despite the large size of this site, very little evidence of medieval occupation was found, most of the features being of Roman date. No features earlier than the 17th or 18th centuries were excavated, these being related to a few post-medieval houses that had stood here and to gravel-digging in the vicinity. The relatively small collection of pottery recovered was mainly post-medieval. This all confirms the impression from cartographic and other evidence that post-Roman occupation in the area was minimal until post-medieval times.

### Magdalen Street (MSC; CAR 6, 341-4)

A small extramural site lying on the south side of Magdalen Street some distance beyond the medieval South Gate. Phased as follows:

Period 1	11th/12th-14th/ 15th century	Hollow way
Period 2a	14th/15th-15th/ early 16th century	Building 158, Phase 1
Period 2b	15th/early 16th-c 1700	Building 158, Phase 2
Period 2c	c 1700-19th/early 20th century	Building 158, Phase 3
Period 3	19th/early 20th century-1974	Brick house

The site began as a sunken street or hollow way ('Grub Street') in the late 11th or early 12th century. Layers of gravel and sand accumulated in this until the 14th or 15th century. Sherds from two or three 13th-century Saintonge or North French jugs and from London-type ware jugs of similar date occurred in the fills and residually in later phases. Building 158, sealing the hollow way, was of three phases. The Phase 2 building was a typical 15th-/16th-century timber-framed structure, though only the mortared plinths survived.

From the ceramic point of view, the most interesting aspect of Magdalen Street was the evidence for nearby pottery production probably around the middle of the 15th century. No evidence of actual kilns was found, but numerous wasters of Colchester-type ware were found in pits and layers within the Phase 2 house. Finds of other pottery waste had been made in the vicinity since 1907 (see p 110). It is possible that pottery production predates Building 158 and could have ceased when a row of new houses was built on the Magdalen Street frontage probably in the 15th century. Brick floors distinguish the Phase 3 house. It was replaced later with a brick house.

**'Spendrite' (SPT; CAR 6, 995-7)**

A small site/watching brief at 61-62 High Street. Early medieval and later pits. The only significant post-Roman feature was the corner of a deep stone and ?brick-lined cess-pit or latrine which produced Stratified Group 13 (SPT F14, c 1500-1525).

**The Gilbert School (GBS; CAR 6, 127-39)**

A large site just inside the western wall of the town. Site of Roman legionary barrack blocks. The site was never intensively occupied in the post-Roman period and was under cultivation for much of this time. The post-Roman pottery assemblage is consequently small and dominated by modern wares from 19th-century sand-extraction pits. The few medieval features (mainly pits and trenches) include a lime kiln and a bronze-working oven for casting bells or vessels. The latter has an archaeomagnetic date of c 1050-1100.

An early medieval sandy-ware vessel (Fig 22.13) was associated with the oven (CAR 6, 137-8).

**St Giles's Church (STG; CAR 9, 221-35)**

The church stands to the south of the town in the grounds of the former St John's Abbey. It was founded in the 12th century and much modified in subsequent centuries. It is now redundant. Phasing is not provided here as the post-Roman pottery assemblage is very small and dominated by post-medieval wares. The most significant ceramic find from the church is a group of medieval floor tiles, possibly manufactured at or near Colchester (*ibid*, 231-4).

**St John's Abbey (StJA; CAR 9, 203-221)**

This includes the excavations in the abbey grounds (StJA), and those in 1972 for the Inner Relief Road B (IRB) which uncovered the late Anglo-Saxon church.

St John's church was a small stone structure demolished in c 1095 to make way for the construction of St John's Abbey. A small amount of pottery was associated with the destruction of the church including a bowl illustrated in this report (Fig 30.54). The Norman abbey of St John was destroyed by fire in 1133, but unfortunately no pottery was found directly associated with this event. A deep layer of soil was dumped on the site after the fire. Graves cutting this soil produced a small amount of pottery including a cooking pot illustrated here (Fig 20.5). The graves probably predate the construction of nearby St Giles' Church in

c 1150. A small amount of late medieval pottery was also recovered from the site.

The pottery from this site has been reported on by Carol Cunningham (CAR 9, 218 and microfiche pp 108-134) and was not recorded for the purposes of this report. The pottery illustrations, however, are published here.

**Butt Road (BUC; CAR 9, 41-63)**

Roman cemetery to south-west of the town. Few post-Roman features. Medieval oven, late post-medieval sand pits and houses. Small collection of post-Roman pottery from Anglo-Saxon onwards, mostly 19th century. Pottery scanned but not recorded.

**Crouch Street (CSC; CAR 6, 785)**

Small excavation/watching brief to south-west of the town. Late medieval and post-medieval pits. Possibly associated with nearby religious foundation of Crouched Friars, and successive post-medieval houses. Fragment of Tudor stove-tile (Fabric 42; Gaimster 1988a, fig 2.4). Pottery scanned but not recorded. Medieval pottery from Crouched Friars reported in CAR 9 (pp 255-6).

**Maldon Road (MRC; CAR 9, 236-44)**

Small excavation to south-west of the town. Roman inhumations. ?Late medieval and post-medieval pits, possibly associated with Crouched Friars and later house. One pit produced a fragment of Tudor stove-tile, possibly from the same stove as that from Crouch Street (Gaimster 1988a, fig 2.3). Pottery scanned but not recorded.

**Trinity Street (TSC; CAR 6, 347-54, 828)**

Intramural site located between Lion Walk and Culver Street sites. Small excavation and post-medieval building survey. Early medieval and later pits and a well. Remains of two 'kilns' built of peg-tile were found (CAR 6, 36 & 323); many of the tiles were warped and vitrified. Two identical 18th-century 'flower pots' were associated with the kilns and appear to be wasters (Fabric 40; Fig 149.182). The function of the kilns is uncertain. They may have been tile kilns which were occasionally used for pottery firing, or they could have been industrial furnaces, perhaps for metal-working. Small collection of Anglo-Saxon to modern pottery recovered from site. Pottery scanned but not recorded.

**Angel Yard (40.86 or AGY; EAH, 27, 35-83)**

Intramural site on High Street next to town hall. Early medieval features, medieval and post-medieval timber-framed building including former Angel Inn. Large assemblage of Anglo-Saxon to modern pottery. Not included in the brief of this report because the excavations began in 1986, but some exceptional vessels are illustrated here including substantial parts of a Colchester-type ware louver (Fig 107.245).



**Osborne Street** (5.88 or OSB; Shimmin 1994)

Extramural site south of town. Late medieval buildings and related features. The pottery is outside the scope of this report because of the date of the excavation, but an exceptional Colchester-type sgraffito sherd is illustrated here (Fig 111.261).

**Other watching briefs and findspots**

Individual items have been illustrated from a number of minor watching briefs and earlier findspots. Details are provided in the concordance of illustrations (Appendix 1) and in *CAR 6* and *CAR 9*.

**Methodology**

[Fig 2]

Quantities: some figures

The computer archive contains information on approximately 100,000 sherds, or around two tonnes, of medieval and post-medieval pottery. Actual totals are as follows:

No of sherds: 78,899 (*see below*)

Weight: 1,953.425 kg

EVEs: 820.72 (*see below*)

Total quantification for all 48 sites in the computer archive was not possible due to time and financial constraints, but pottery weight per fabric and context was always recorded. Data from the fully recorded sites suggest the figures presented above for sherd numbers and EVEs represent around 80% of the true totals. It must be emphasised, however, that all the chronological bar charts presented in this report are based only on contexts where 100% pottery quantification was carried out (*see below*, 'Ceramic phasing').

Because of the volume of post-Roman pottery from the 1971-85 excavations, a recording strategy was developed when it became apparent that full Level III recording of all the pottery would not be possible.

Pottery from 83 sites and watching briefs was available for examination. Initially all of this was briefly examined, spotted and roughly quantified by weight. Data from this initial quantification has not been used in this report. On the basis of this overview, 32 sites were eventually selected for full Level III recording in view of the large and well-stratified pottery assemblages that most of them produced.

The Level III computer record contains information on site code, context, fabric type, quantification (number of sherds, weight, EVEs), vessel part, vessel form, handle type, rim, base and spout type, rim diameter, glaze type and position, slip type and position, other decoration, traces of use, site or ceramic phasing and any other comments. The 32 sites selected for full recording were: LWC A-E, G, H, J-N, Q, S, U; 1.81 G; COC; CPS; BKC A, C, D, H, J, M, N, V; MID C, E, X; MSC; SPT; and STG.

In addition to these sites, all of the 22 Stratified Groups selected for publication were also fully recorded. The ceramic phasing file (*see below*) was drawn only from these fully quantified sites and contexts. Modern fabrics (ie mainly 19th-century fabrics, code Fabric 48) were not fully

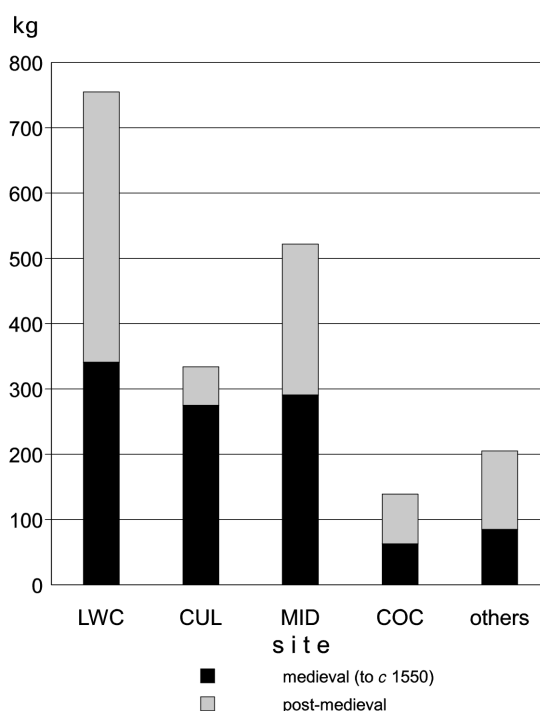

Fig 2 The main sites: bar chart showing pottery quantities by weight and date (medieval/post-medieval).

recorded. This would have been of dubious value, particularly as 19th-century levels were often machined off and these non-local wares of the industrial period have been the subject of numerous antiquarian books. Consequently, on those sites where the pottery was fully recorded, the modern wares were only identified by fabric code and quantified by sherd numbers and weight. On other sites modern wares were quantified by weight only.

Sixteen other sites out of the 83 received summary computer recording. At its most basic, the summary computer record contains information on site code, context, fabric code, vessel form, rim and base form, and the collective weight of all sherds of that fabric in that context. Occasionally more details have been provided. Summary computer recording was applied to the following sites: 1.81 A-E, H, J, K, M, W; GBS A, B; LWC R, V; MID A/B (MID Y).

The remaining 35 sites and watching briefs were 'scanned' simply to determine what fabrics were present and whether any items were worth adding to the illustrated vessel typologies or the fabric reference collection. This data was not recorded on computer (for list *see* 'The sites: a gazetteer' above).

In the fabric typologies set out below (Chapters 2-13), it should be borne in mind therefore that the quantities listed for each fabric will normally represent only about 80% of the true totals present (**indicated by an asterisk**, except weight where 100% is always given). In practice, however, fabrics represented by less than a hundred sherds have usually been presented together with their full quantification. This is particularly the case with the rarer foreign imports. Thetford-type ware (Fabric 9) has also been fully quantified, but nothing larger than this.

**Classification and methods**

[Fig 3]

The pottery in this report was recorded following a system for classifying post-Roman pottery from Essex first devised by Carol Cunningham during the late 1970s/early 1980s, but not fully published until 1985 (Cunningham 1985, 1-16). The basis of this system is a hierarchy of alpha-numeric codes allowing fabric, vessel form (eg bowl, jug etc), vessel sub-form (eg rim and base form), and other attributes to be recorded as a series of fields comprising a computer record. This system was expanded and adapted as necessary.

The list of fabric codes used for post-Roman pottery in Essex has, of necessity, been extended by the need to accommodate new fabrics recognised in the county in the decade or so since Carol Cunningham's 1985 report, so much so that it is now desirable to provide an enlarged and updated list which is presented below. Because this is an evolving system, tied to on-going research, the list presented below is itself only a reflection of current knowledge and it too will require revision as research progresses. Because it has evolved over several years with input from several individuals, the list is not entirely logical, but these inconsistencies are often only visible with hindsight. Fabric 23C, for example, a white ware from the Low Countries which is almost exclusively post-medieval in date, is inappropriately placed under the Fabric 23 heading, which otherwise comprises only English medieval white wares, but for the sake of maintaining record consistency over the years the decision was taken to leave it as it is.

Although the original 1985 list claimed to be a 'fabric list', this was not entirely correct. It was, and still is, a list of generic pottery names which include wares, ware types, fabrics and form/fabric associations (eg Marticamp flasks, Spanish olive jars etc). The revised list of pottery codes presented here contains the original 1985 codes, modified where necessary, together with new codes created by Helen Walker for the County Archaeological Unit and published in her reports between 1988 and 1995 (see bibliography), as well as many others created specially for this report — particularly for Colchester's wide range of foreign imports which remains unparalleled elsewhere in the county.

It must be stressed that the common names used for the 'fabrics' listed below and throughout this report are deliberately simplistic tending towards more established terminology. Terms such as 'Thetford-type wares', 'St Neots-type ware' and 'Saintonge ware' are often used here in a generic sense, though it is acknowledged that the reality is often more complex. There are, for instance, a number of 'wares' (ie products from specific kilns or production centres) sheltering under the Thetford- and St Neots-'type' labels, and within each 'ware' there may be a number of 'fabrics' and fabric 'variants', and so it is with many other such labels of convenience.

In general, the use of form and sub-form codes has been avoided in this report in favour of common names or simple descriptions, though in a few cases (eg Fabric 40, post-medieval red earthenwares), form codes and descriptions have sometimes been used together to make clear the basis of any larger form groupings under discussion and to allow cross-referencing back to the original computer archive, should this be necessary.

**Essex post-Roman pottery codes**

(Adapted from Cunningham 1985)

Note that only the codes indicated with an asterisk have been used in this report and are further considered in the main text. The other fabrics do not occur in Colchester.

Gaps in the numbering sequence indicate vacant codes.

- 1\* *Anglo-Saxon vegetable-tempered ware (general)*
- 1A *Early Anglo-Saxon vegetable-tempered fabric*
- 1B *Mid-Saxon hard vegetable-tempered fabric*
- 1C *Vegetable- and sand-tempered fabric*
- 2 *Saxon plain brickearth fabric*
- 3 *Saxon sand-tempered brickearth fabric*
- 4 *Other Saxon brickearth fabrics (general)*
- 4A *Haematite-tempered brickearth fabric*
- 4B *?Import, Schlickung-treated brickearth fabric*
- 4C *Chalk-tempered brickearth fabric*
- 7 *Maxey-type ware*
- 8\* *Ipswich ware*
- 8V\* *?Mid-Saxon wheel-turned 'bottle'*
- 9\* *Thetford-type wares*
- 10\* *St Neots-type ware*
- 11A\* *Stamford ware*
- 11B *Developed Stamford ware*
- 12\* *Early medieval shelly wares (general)*
- 12A\* *Shelly wares without sand*
- 12B\* *Slightly sandy shelly wares*
- 12C\* *Sandy shelly wares (sand predominant) — code used elsewhere to denote a sandy fabric like 13S (see below) with only superficial shell (see Walker 1991a, 29)*
- 12D\* *Oolitic wares*
- 13\* *Early medieval sandy wares (general)*
- 13S\* *Shell-dusted sandy ware (see 12C above)*
- 13T\* *Transitional sandy ware*
- 13St *'Stansted ware' (see Walker 1992b, 47)*
- 14A\* *Pingsdorf-type ware*
- 14B\* *Brunssum-Schinveld ware*
- 15 *Badorf-type ware*
- 16 *Tating ware*
- 17\* *Andenne ware*
- 17X\* *Miscellaneous early medieval Low Countries white wares*
- 18\* *Paffrath-type ware*
- 19 *Normandy (red-painted) wares*
- 20\* *Medieval sandy greywares (general) — elsewhere 'Medieval coarsewares'*
- 20A *Mile End (Colchester) coarseware — not used in this report*
- 20B *Great Horkesley (Colchester) coarseware — not used in this report*
- 20C *Mill Green coarseware*
- 20D *Heddingham coarseware*
- 20E *Rayleigh coarseware*
- 21\* *Medieval sandy orange wares (general)*
- 21A\* *Colchester-type ware*
- 21B *Colchester 'slip-painted' ware — not used in this report but has been elsewhere (see Walker 1988b, 78)*
- 21C *Sgraffito ware (Cambridge-style)*
- 21D *Harlow ware (see Walker 1988a, 181; 1991d, 109)*
- 22\* *Heddingham ware*
- 23\* *Medieval white wares (general)*
- 23A\* *Medieval Surrey white wares (general)*
- 23B *Coarse white wares, unclassified*
- 23C\* *Low Countries white earthenwares*

- 23D\* Kingston-type ware  
 23E\* Cheam white ware  
 23F\* Coarse Border ware  
 24A\* Scarborough ware: Phase I fabric  
 24B\* Scarborough ware: Phase II fabric  
 24X\* Other Yorkshire wares  
 25 Lincoln-type (developed splashed glaze) ware  
 26 Oxford-type ware  
 27\* Saintonge ware  
 28\* Rouen-type ware  
 29A\* Spanish olive jars  
 29X\* Miscellaneous Iberian green glazed wares  
 30\* Beauvais earthenwares  
 31\* Low Countries red earthenwares (general)  
 31A\* North Holland slipware  
 32 Low Countries greywares  
 33 Highly decorated Low Countries ware ('Aardenburg'-type)  
 34 Unclassified buff wares  
 35\* Mill Green ware  
 35B Mill Green-type wares (see Walker 1990b; Walker 1995)  
 36\* London-type ware  
 38 Grimston-type ware  
 39\* North Italian marbled slipware  
 40\* Post-medieval red earthenwares (general)  
 40A\* Metropolitan slipwares  
 40B Stock-type black glazed ware  
 40C\* Cistercian wares  
 40D\* Wrotham slipware  
 40E\* Sussex inlaid slipware  
 41\* 'Tudor Green' ware  
 42\* Surrey/Hampshire Border white ware ('Border' ware)  
 43\* Martincamp flasks  
 44\* German slipwares (general)  
 44A\* Weser slipware  
 44B\* Werra slipware  
 44C\* Lower Rhine slipware  
 45\* English stoneware (17th- to 18th-century types)  
 45A\* Langerwehe stoneware  
 45B\* Siegburg stoneware  
 45C\* Raeren stoneware  
 45D\* Frechen stoneware  
 45E\* Cologne stoneware  
 45F\* Westerwald stoneware  
 45G\* Nottingham/Derbyshire stoneware  
 45H Oriental stoneware  
 45J\* Beauvais stoneware  
 45K\* Gothic (Saxony) stoneware  
 45M\* Modern English stoneware (19th- to 20th-century types)  
 45N\* Normandy stoneware  
 45S\* Nieder Selters-type bottles  
 45X Miscellaneous unidentified stoneware  
 46\* Tin-glazed earthenware (general)  
 46A English tin-glazed earthenware  
 46A/C Anglo-Netherlands tin-glazed earthenware  
 46B\* Spanish lustrewares (general)  
 46B/1\* Andalusian lustreware  
 46B/2\* Valencian lustreware  
 46C\* South Netherlands maiolica  
 46D\* Other Spanish tin-glazed earthenwares (general)  
 46D/1\* Seville (Cuerda Seca)  
 46D/2\* Seville maiolica  
 46E\* Italian Montelupo maiolica  
 46F\* Portuguese maiolica  
 47\* Staffordshire-type white stoneware  
 48 Porcelain and late post-medieval factory wares (general)  
 48A\* Chinese porcelain  
 48B\* English porcelain  
 48C\* Creamware/Queensware  
 48D\* Staffordshire-type white earthenwares  
 48E\* Yellow ware  
 48J\* Jackfield ware  
 48L\* Lustre ware  
 48P Pearlware — not used in this report (see 48D)  
 48R\* Red stoneware  
 48V\* Sanitary wares  
 48W\* 'Whieldon'-type wares  
 48X\* Miscellaneous earthenwares  
 49\* Basalt ware  
 50\* Staffordshire-type slipware  
 50A\* Staffordshire-type iron-streaked earthenware  
 51A\* Late slipped kitchenware  
 51B\* Flowerpot  
 52\* Mediterranean 'mercury' jars  
 53\* Iberian storage jars  
 54\* Italian oil jars  
 55\* Guy's-type ware  
 56\* North Devon gravel-tempered ware  
 57\* Merida-type ware  
 58\* Martabani stoneware (south-east Asia)  
 60\* 'Hessian' crucibles  
 62\* Iberian/North African star costrels  
 95\* Unidentified foreign wares (general)  
 95M\* Unprovenanced French micaceous ware  
 95P\* 'Pudding Lane'-type North French glazed ware  
 97\* Saxon 'brickearth' fabrics (general) — see Fabrics 2-4C  
 97F\* Wheel-thrown Frankish sandy wares  
 98\* Miscellaneous unidentified medieval/post-medieval  
 ?English wares (general)  
 98S\* Non-local slip-painted ware  
 98W\* 'Long Wyre Street' ware

Unless otherwise specified, fabric descriptions in this report follow the standards used by the former Department of Urban Archaeology, London, now MoLAS (*DUA Pottery Archive Users' Handbook*, 1984). Fabric descriptions are based on visual and tactile examinations of sherd surfaces and fresh breaks, both with the naked eye and at x20 magnification. Discussion of inclusion size normally carries the following significance:

Very fine:	up to 0.1 mm
Fine:	0.1 to 0.25 mm
Medium:	0.25 to 0.5 mm
Coarse:	0.5 to 1.00 mm
Very coarse:	greater than 1.00 mm

Munsell colour names have not been used, only the apparent colour name.

## Reference collections and archives

All vessels illustrated in this report are stored for future reference in Colchester Museum, and a pottery fabric reference collection has been established at the Colchester Archaeological Trust. A large selection of Colchester and north Essex post-Roman pottery fabrics has been presented

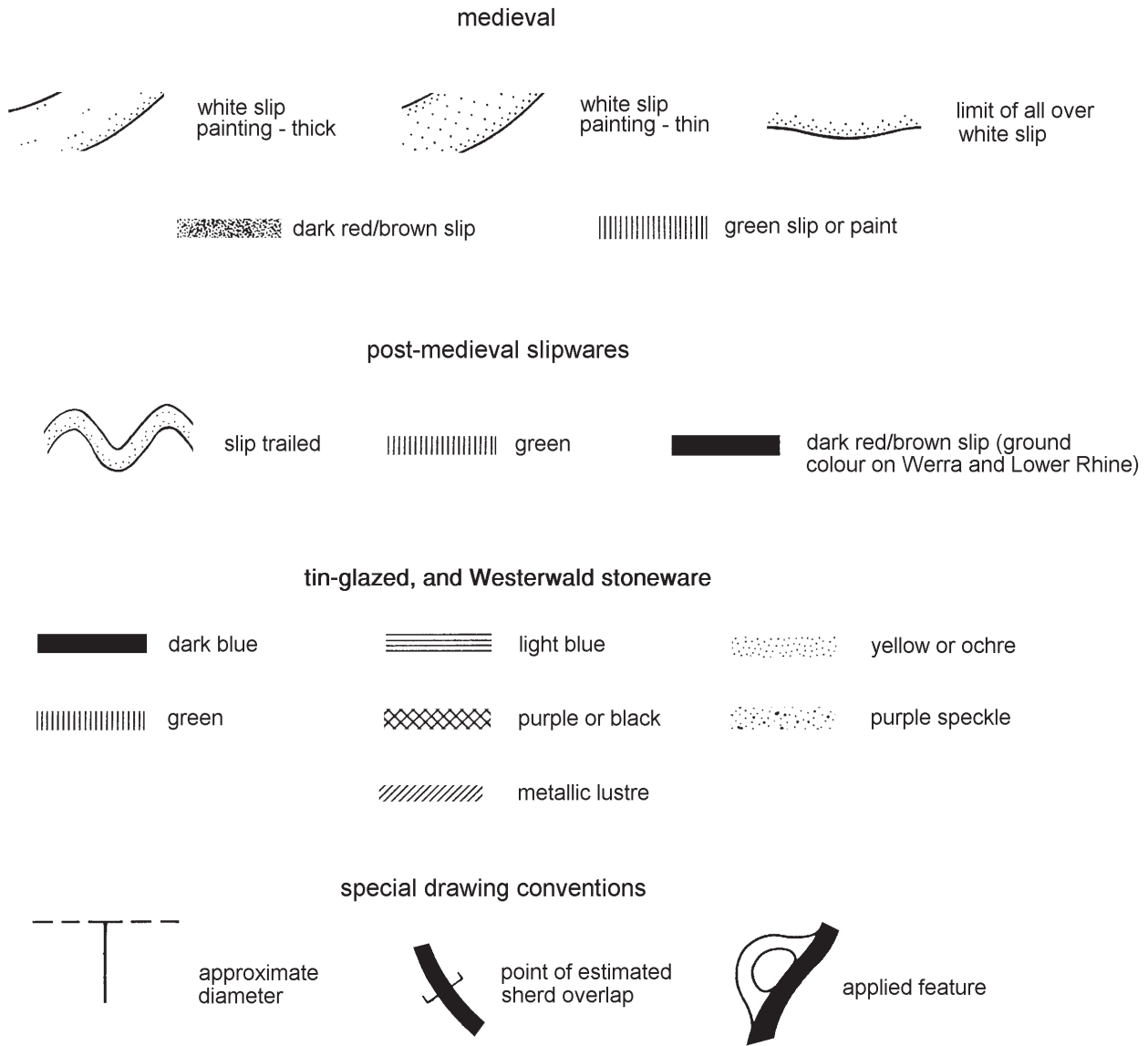

Fig 3 Key to drawing conventions.

to the British Museum reference collection of medieval and post-medieval fabrics and is available for inspection there.

**Pottery dating and ceramic phasing**

Unlike London and some other ports, Colchester has no excavated medieval waterfront sequences with associated dendrochronological and numismatic dating. The general sequence of pottery types present in Colchester, and detailed in this report, is not in doubt. The same broad picture is confirmed on site after site where the stratigraphy is deep enough to make such observations. What is less certain, however, are the historical dates that should be attached to the changing trends observable in the ceramic sequence, and here there still remains room for refinement when new information comes to light.

**Pottery dating methods**

Post-Roman pottery from the Colchester excavations has been dated by a combination of methods, most of them traditional and well-established. Relative dating of pottery types has been established by their stratigraphic position, and for this one of the most useful stratigraphic summaries is provided by the section through the early medieval town ditch at Lion Walk where a sequence from late Saxon to post-medieval is observable in a single section (Fig 208).

Dating by association has been used a great deal. Local pottery types have been dated by association with coins, tokens, leaden cloth seals, clay pipes and any other closely datable artefact in the same or a related context. Coins, however, are infrequent on the excavations, and are also just as subject to residuality as the pottery itself; they need therefore to be used with caution. Better-dated pottery types have also been exploited for their dating potential, particularly the various manifestations of London-type ware (Pearce *et al* 1985) and even its Heddingham ware

derivatives. Mill Green ware (c 1270-1350) is also sufficiently common to provide dating (Pearce *et al* 1982), and imported German stonewares have been heavily relied on for dating in the late medieval and post-medieval periods.

Dating by typological similarity has perhaps been used most of all, either because local pottery types have copied or come to resemble better-dated non-local wares (eg Heddingham copying London-type ware, Colchester copying Mill Green ware, etc), or because local vessels without good dating can be related typologically to similar local vessels with better associated dating. Ultimately dating by association lies at the root of most typological comparisons.

Absolute dating provided by documented events or scientific dating has been used least of all in Colchester. Colchester's wealth of municipal records hold considerable potential for identifying the history and ownership of excavated buildings and property, but for archaeological purposes this source has remained largely untapped.

A few document-dated contexts have been identified, including the remains of a small Anglo-Saxon church demolished in c 1095 in the grounds of St John's Abbey and deposits associated with the total destruction by fire of St John's Abbey in 1133, but these have produced only very small pottery assemblages. Rather more pottery was recovered from the large robber trench associated with the refurbishment of the town wall c 1382-1421 (Stratified Group 9), but remarkably little pottery can be associated with the 1648 siege of Colchester which destroyed nearly 200 houses in the town.

Only one scientifically dated feature has relevance to medieval pottery, and that is an 11th-century bronze-working oven on the Gilbert School site associated with a single cooking pot.

#### Ceramic phasing

[Figs 4a-b]

In order to establish a broad quantitative picture of the ceramic succession at Colchester, a system of ceramic phasing, or a dating framework, was established for pottery from the 1971-85 excavations.

Firstly, the most useful and reliable stratified sequences on each site were ascertained by an examination of all the relevant stratigraphic records. Dubious contexts were excluded and the better ones selected. If not already processed, pottery from the selected contexts was then fully recorded and quantified in terms of numbers of sherds, weight and EVEs.

The site phasing assigned by the excavator to individual sites was re-examined, and where necessary (particularly where dependent on earlier pottery spot-dates) the phasing was adjusted or subdivided (*see* 'The sites: a gazetteer' above). The relative date of site phases thus being established, absolute dates were then assigned to phases on the basis of the pottery itself and any associated dating evidence provided by coins or other artefacts.

Fully quantified data from these 'absolutely' dated contexts was then drawn off to a ceramic phasing database arranged in five broad periods (Periods 1-5, ie Anglo-Saxon, early medieval, high medieval, late medieval and post-medieval). Where possible, each of these was further subdivided into as many as four 'sub-periods' of anything between 25 and 100 years (*see* below). The inequality of the resultant period/

sub-period lengths and the need for broad cross-period codes (such as 3/4.1) were dictated by the archaeology itself, since some periods (eg late Saxon and the late 16th century) are only poorly represented in the town, while some contexts in otherwise useful sequences contained too little pottery to be assigned more definite dates.

The majority of contexts drawn from sites previously phased by the excavator represent occupation levels usually associated with buildings. In terms of quantity and preservation, however, the best ceramic assemblages often occur as isolated rubbish-pits or robber trenches which are rarely part of a useful stratified sequence. Twenty-two of these 'Stratified Groups' have been selected to illustrate the range of post-Roman ceramics from Colchester in each period. These have also been assigned absolute dates, sometimes on the basis of context but most often on the basis of typological comparison. The quantified data from these pit groups was then added to the same database as the occupation levels. The ceramic phasing database thus created comprises data from over 800 contexts, representing approximately 37% (by weight) of all the excavated pottery from the 1971-85 excavations (Fig 4).

The stringing together of more or less contemporary stratigraphic horizons on different sites around the town has the advantage of creating a larger period sample than could be obtained from any one site. Such a sample has the added advantage of reducing the biases present on any one site (eg status or functional bias) by balancing it against the data from several other sites, thus allowing a more representative picture of the town's ceramics to emerge for any given period. In terms of the bar charts presented in this report, the most useful periods are the eleven more or less consecutive periods (Periods 2.1, 2.2, 2.3, 2.4, 3.1, 3.2, 4.1, 4.2, 5.1, 5.2, and 5.3). These allow a clearer chronological overview of changing ceramic proportions to be obtained. Most of the other periods have a supplementary function and are usually referred to in the text only.

#### Colchester ceramic phasing

Period	Date
1	Anglo-Saxon
2	1000-1200
2.1	1000-1100
2.2	1100-1125
2.3	1125-1150
2.4	1150-1200
3	1200-1400
3.1	1150/1200-1250/75
3.2	1250/75-1400
4	1400-1550
4.1	1350/1400-1500
4.2	1450-1550/80
5	1550 onwards
5.1	1550-1600
5.2	1600-1675/1700
5.3	1680/1700 onwards

The following cross-period codes are sometimes referred to in this report:

Period	Date
2.2-3	1100-1150
2.2-4	1100-1200
3-4	1200-1550
3/4.1	1200-1400/1400-1500
4.2/5.1	1450-1550/1550-1600
4.2/5.2	1450-1580/1600-1675/1700

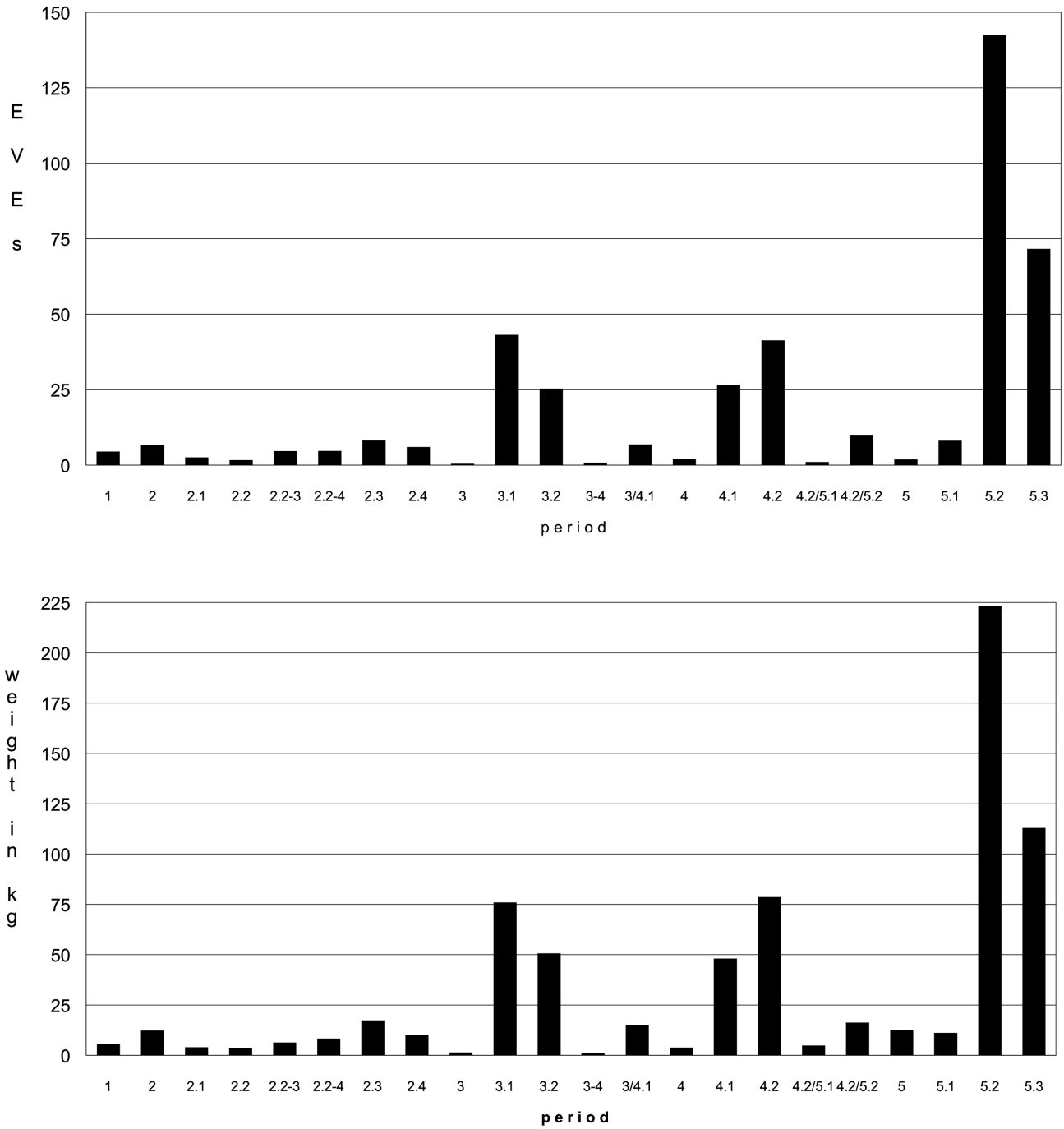

Fig 4a-b Ceramic phasing: bar charts showing sample size per period, by EVEs (above) and weight (below). Totals represented: 418.22 EVEs, 720.01 kg.

**Explanation of the bar charts**

With the exception of those bar charts where absolute quantities (weight/EVEs) are represented (Figs 4a & 4b) and the charts dealing with metrical data (ie rim diameter — Figs 23a-b, 38a-b and 56a-b), all the remaining bar charts in this report deal with the percentages of different wares in stratified contexts (ie the ceramic phasing). Such bar charts

are based exclusively on the fully quantified data from the ceramic phasing database discussed above. Unless otherwise indicated in the caption, all the pottery in a given ceramic period represents 100% of that ceramic period assemblage. In Figure 17, for example, 97% of all pottery (by EVEs) in Period 2.1 (c 1000-1100) is early medieval sandy ware (Fabric 13), while in Period 3.2 (c 1250/75-1400) it forms only 25% of the assemblage dated to that period.

## Historical background

Colchester was always an important regional town and saw its share of the major historical events that affected lowland England. Perhaps by virtue of its very ordinariness, the archaeology of medieval Colchester, including its pottery, has a special value in that it reflects what was commonplace and typical in a moderately prosperous English medieval town, rather than that which was exceptional.

The following outline of Colchester's post-Roman history is intended to give some impression of the topographical, cultural and political context in which the archaeology is set. Particular reference is made to economic history and other factors likely to be reflected in ceramic assemblages from the town. Unless otherwise stated the main sources from which this summary is drawn are *CAR 1* (*Aspects of Anglo-Saxon and Norman Colchester*, 1981); Richard Britnell's *Growth and decline in Colchester, 1300-1525* (1986); and the *Victoria County History of Essex, 9: Colchester* (1994). More detailed accounts of Colchester's overseas trade links (with full references) can be found at the start of each chapter on foreign wares (Chapters 7-12). Other documentary references to local pottery manufacture and trade are listed in Appendix 2.

The medieval town inherited the rectilinear shape of its Roman predecessor. The Roman wall enclosed a rectangular area of 109 acres, bisected by an east-west high street and, in the western half, by a north-south road known as Head Street. Roman roads linked Colchester with London, 50 miles away to the south-west, and with Norwich, the same distance to the north. On the north side of the town, the River Colne winds its way south and eastwards, widening into a muddy creek before entering the North Sea. The creeks around Colchester have long been famous for their oysters, which made a significant contribution to the town's later prosperity.

The Colne was navigable as far as Colchester's port at the Hythe which lay a little to the east of the town. The Hythe was never a major port; for all Customs purposes it came under the jurisdiction of the port of Ipswich, but it allowed Colchester a measure of direct sea trade. Owing to constant silting, the Hythe was often only accessible to smaller craft: larger sea-going vessels commonly had to unload further down river at Wivenhoe. Foreign goods, such as wine and mill-stones, were just as likely to have reached Colchester via the more important medieval ports of Harwich and Ipswich (Britnell 1986, 13).

To the south of the town, around Langenhoe and the Layers, lay the best agricultural lands for cereal growing and dairying. A belt of poorer soils marked by heath and woodland stretched from the west side of the borough of Colchester at Lexden through Mile End and as far as Ardleigh to the north and north-east. Here, in these marginal areas, where the London clay was interspersed with sands and gravel, most of the evidence for local pottery and brick-and-tile-making in the post-Roman period is concentrated (see Appendix 2).

After the Roman period, there are no historical references to Colchester until the 10th century. There is a passing reference to the town in the Ravenna Cosmography of c AD 700, but this is almost certainly retrospective. The town is presumed to have succumbed to Saxon invaders c AD 450. Evidence for Saxon occupation is sparse. Three Anglo-

Saxon sunken huts of the 5th to 7th centuries have been excavated (see 'The sites: a gazetteer' above). Anglo-Saxon pottery is mostly of the local hand-made types (Fabrics 1 and 97). Some vessels may have been imported from the kingdom of Mercia (Fabric 12D), and one vessel in Ipswich ware has been recognised (Fabric 8; c AD 725-850). Sherds from three or four imported Carolingian or Frankish vessels have also been found (Fabrics 8V and 97F).

Other artefacts of the Anglo-Saxon period are rare (*CAR 1*). Finds of any sort datable to the 8th to 9th century are so few that Philip Crummy has suggested that the town was either deserted during this period or that the population was minimal and perhaps aceramic (*CAR 1*, 72).

A Danish settlement may have been established in Colchester after the Treaty of Alfred and Guthrum in 879. Edward the Elder recaptured the town from the Danes in c 917, and later in that year returned to repair the damaged wall (*ibid*, 24). Edward was probably responsible for initiating the urban renewal of the town by the laying out of new streets and perhaps other works (*ibid*, 73-4). In 931, King Athelstan held a council at Colchester which was referred to as 'a town well known to all men' (*ibid*, 25). King Edmund also held a council here in 940 (*VCHE*, 9, 19), and a mint was established in the 990s.

Artefactual evidence for the late Saxon period is not particularly abundant and mainly limited to several hundred sherds of Thetford-type ware (c 850-1150) and a few other artefacts. The most impressive vestige of this period is the tower of Holy Trinity Church (probably early 11th century), constructed entirely of Roman brick and rubble. The only late Saxon features found on the 1971-85 excavations were a few rubbish-pits at the Cups Hotel site in the High Street and the foundations of a small church in the grounds of St John's Abbey.

As the distribution of Thetford-type ware indicates, occupation was concentrated on the High Street until perhaps the 12th century (see pp 30-1). Large areas within the walled town were under cultivation and this situation continued, on a diminishing scale, well into the post-medieval period.

Colchester and Maldon were the only boroughs in Essex mentioned in Domesday (1086), and Colchester was the more important of the two. It contained at least 419 houses and an estimated 2,500 or more inhabitants (*VCHE*, 9, 21). The Norman town was dominated by the castle, the largest Norman keep in the country. Other imposing Norman works included St Botolph's Priory and St John's Abbey to the south of town, and a fine Norman Moot Hall stood on the site of the present town hall until the 19th century.

By the 14th century there were at least two friaries and several chantries and religious hospitals around the town. Most domestic architecture was of wood and daub, but at least seven stone houses of the 12th century are known, and there may have been many more than this. Apart from the Moot Hall with its Romanesque doorway and windows, there was little in the way of fine architecture in medieval Colchester. Nearly all the parish churches, the castle and even the largest religious buildings were built of reused Roman brick and rubble embellished here and there with carved stones from outside the county.

The castle remained in royal hands for much of its life though it was intermittently in the possession of hereditary constables. It was the focus of some of the more significant

historical events in medieval Colchester. In 1216, for example, King John besieged the castle which was in the hands of a baronial partisan and a contingent of French soldiers.

On a national scale Colchester ranked as only the 27th most important provincial town in the 1130s. Two hundred years later it ranked only 46th (*VCHE*, 9, 21-3). Much of the town's early importance and prosperity lay in its role as a market for agricultural produce, its position on the route between London and East Anglia, and its ease of access to the sea.

The borough was granted its earliest known royal charter in 1189 (perhaps a modification of an earlier one) which conveyed significant privileges and liberties upon its burgesses (*ibid*, 48). These privileges were jealously guarded down through the centuries and were an enduring source of civic pride. A small but wealthy Jewish community appears in the town records between the late 12th and the early 14th centuries (Stephenson 1985). They had their own synagogue and owned several properties close to the market area (the High Street), particularly in the two Stockwell Streets where the Jewry is believed to have been located. The community was highly mobile and had connections and relatives in many other towns and cities, even in France and the Holy Land. Two exceptionally large 13th-century coin hoards, found in lead canisters, are thought to have been deposited by Jews. The canisters contained a total of 24,000 silver pennies and were found on the High Street, opposite the Moot Hall.

Up to 45% of the population may have died in the Black Death, but the town recovered quickly, mainly due to a flow of outsiders attracted by the town's growing cloth industry (*VCHE*, 9, 24). The sudden burst of Flemish names in records of the 1350s strongly suggests that foreign expertise played a part in invigorating this local industry (Britnell 1986, 72). Colchester was one of the most important English cloth towns in the Middle Ages and perhaps more so in the post-medieval period. Tanning, leather-working and fishing were also important local industries in the 14th century, but gradually cloth became the mainstay of the town's prosperity for several centuries.

'Colchester russet', a grey cloth, was much in demand for its quality and suitability where sombre attire was called for. As early as 1249, Henry III bought Colchester russets to clothe his servants (*VCHE*, 9, 28), and in the late 14th century the archbishop of Bordeaux also chose to clothe his household in Colchester cloth (Britnell 1986, 63).

Colchester cloth was known by name in most of northern Europe from France to Scandinavia and Prussia. In southern Europe, even as far as Damascus, Colchester cloth was sometimes recognised by name but more often lumped together with other Essex cloths (*ibid*, 53-68). Colchester merchants traded directly with the Baltic, the Low Countries and Gascony, cloth being the main export. Baltic imports consisted of fish, wheat and forest products such as wax, bitumen and timber from the east Baltic, salt and iron from Scandinavia, and linen cloth, thread and beer from north Germany. The Baltic trade in the later 14th century marked Colchester's most adventurous period of direct maritime trade, a venture in which it competed successfully with the more dynamic east coast ports of London, Norwich, Kings Lynn, Boston, Beverley and Hull, and with merchants from York and Bristol (*ibid*, 64). The parallel decline of Ipswich as a port in the 14th century may have benefited Colchester's position in these ventures (*VCHE*, 9, 31).

From the 1390s, German merchants of the Hanse dominated the Colchester cloth trade and the import of dyestuffs, particularly woad from the Low Countries. The peak of this activity was in the mid 15th century, when the town had a number of Hanseatic residents (*VCHE*, 9, 33-4; Britnell 1986, 173-6). Through the German link, Colchester cloth was traded as far as Russia (*ibid*, 169). The Germans chartered Dutch shipping to carry the cloth. The majority of foreign vessels visiting the Hythe were always from the Low Countries (a trend that increased in the post-medieval period). Imports from here included dyestuffs, hand cards, metal ware and cloth (*ibid*, 177).

The town's customary records for the late 14th century also demonstrate the importation of 'Flanders tile' and probably earthenware. Rhenish wine, stoneware and glass were also imported as was olive oil and soap from Spain and Portugal (see relevant chapters on imports and Appendix 2).

The trade with Gascony was a direct bilateral exchange of Colchester cloth for wine. Salt was also imported from the Bay of Bourgneuf (*ibid*, 63). A London merchant traded from Colchester in 1374 with Gascony and Spain, and at least one Colchester merchant was in Spain in c 1480. There was also some trade with Calais (*VCHE*, 9, 32). Trade with the Mediterranean was almost entirely conducted through Italian merchants based in London and Southampton (Britnell 1986, 65-7). Most Mediterranean goods would have been redistributed from these ports and perhaps from ports in the Low Countries.

Wool was brought considerable distances to supply Colchester's textile industry, even from as far as Gloucestershire. Colchester's merchant debtors and creditors in the late 14th century came from as far away as Southampton, Lewes, Norwich, Westminster, and York (*VCHE*, 9, 32). Merchants from Norwich, Kings Lynn and Yarmouth were trading in Colchester in the late 13th century, and French merchants from Amiens and St Omer traded here in 1305 (*ibid*, 30).

Road and coastal links with London were always important, particularly in the later 15th century when Colchester's trade with north-west Europe declined and trade with London intensified as a consequence (*ibid*, 34).

In 1357, four Colchester townsmen of substance acknowledged themselves bound to Thomas Crouchman, citizen and potter ('*ollarius*') of London, for £22 and 9 shillings debt (*JCR*, 50). The size of the debt suggests Crouchman was a dealer or founder of metal-ware rather than earthenware pots.

Coastal trade with other parts of Britain was a regular occurrence though not always in Colchester ships. An example of these complex links occurred in c 1387, when three Colchester merchants sailed from the town with a small boat of merchandise bound for Scone near Perth. Bad weather drove them off course to the Norwegian coast, where they were intercepted by Dutchmen who seized part of their cargo and took them as prisoners to Holland where they were eventually ransomed. The boat that they had sailed in from Colchester was Dutch, and this may have been the cause of the altercation (Cockerill & Woodward 1975, 3). Such complex coastal and overseas movements illustrate how goods from Colchester could end up almost anywhere in the North Sea region just as easily as foreign goods could reach Colchester.



A recurrent theme of the late medieval and post-medieval town was its political and religious nonconformity. At least one of the leaders of the Peasants' Revolt of 1381 was a local man, John Ball, and the other leader, Wat Tyler, may have been from Colchester but the evidence is inconclusive. St John's Abbey was attacked by rioters during the revolt and some of the Court Rolls were burnt (*VCHE*, 9, 24-6). In the 15th century the town was a centre of Lollardy (*ibid*), and during the reign of Mary in the following century many protestant martyrs were burnt at the stake.

Between c 1382 and 1421, the town wall was refurbished and new bastions added. This was partly a response to the revolt of 1381 and partly a defensive measure against the threat of French invasion. One of the stratified pottery groups (Stratified Group 9) is associated with these works.

The Duke of Norfolk, who was constable of both Colchester and Norwich castles, was a regular visitor and occasional resident of 15th-century Colchester, though most of his time was divided between his London and East Anglian residences. In his meticulous household accounts is recorded an order placed in 1466 for eleven dozen pots from the kilns at Great Horkesley near Colchester, where most Colchester-type ware was made (see p 110 and Appendix 2). Norfolk built a residence in the High Street just three or four years before his death at the Battle of Bosworth in 1485 (*VCHE*, 9, 44). The building was enlarged by Norfolk's heirs in the early 16th century and became the Red Lion Inn, an impressive and finely detailed timber-framed building that survives as a prominent feature of the modern High Street.

Significant economic growth continued through the 15th and 16th centuries, though not without setbacks. By c 1525, the town ranked as the ninth wealthiest in England although the population was only around 4,000 (*ibid*, 67 and 76; Britnell 1986, 262-8). Wealth became increasingly concentrated in the hands of a small oligarchy of ruling families who controlled the cloth industry and owned much of the surrounding land. Although Ipswich remained the principal town of the region in the 16th and 17th centuries, Colchester was by far the largest town in Essex (*VCHE*, 9, 70).

The Dutch or Flemish community was an increasingly significant element of the town's urban character and cloth prosperity. Flemings held official positions in the town from as early as the 12th century. Many of the approximately 38 aliens living in the town in the 1440s were probably Flemish (*ibid*, 61). The declining textile industry was revitalised in the 1560s and 1570s by the arrival of hundreds of Dutch refugees escaping from religious persecution in the Low Countries. The 'new draperies' introduced by the Dutch, particularly their 'bays, says and perpetuanas', were lighter and cheaper than anything manufactured in England before and found a ready market throughout Europe (*ibid*, 81-2).

The Dutch were granted considerable privileges in Colchester. They exercised tight control over the quality of manufactured cloth, thus making Colchester bays a byword for quality throughout the 17th and early 18th centuries. By the mid 17th century, the size of the Dutch community had stabilised at about 1,500 in a total population of some 10,500-11,000 (*ibid*). The Dutch maintained their own Dutch-speaking church in the town until 1728 (*ibid*, 351).

The town suffered badly during the Civil War. It was besieged by the Parliamentarians for eleven weeks in 1648 and at least 193 houses were destroyed. Several churches and the town wall were also badly damaged (*ibid*, 105-6). Plagues were recurrent in the 16th and 17th centuries.

The plague of 1665-6 killed approximately half the town's population, making it one of the most destructive outbreaks of plague ever experienced by an English town in the post-medieval period (*ibid*, 68). Remarkably the town soon recovered.

The market and fairs continued to be important, and besides the cloth industry there was a wide diversity of other manufacturing and agricultural trades. Hides and leather were important products and the Dutch stimulated the development of horticulture.

From the late 16th century onwards, most of Colchester's cloth exports were conducted through London, much of it destined for the Iberian peninsula, particularly in the 17th and 18th centuries. Colchester shared in the general rise of coastal trade and communicated with many British ports, but mainly London and other east coast ports. Apart from cloth, the main goods sent to the capital were cheese, butter, wheat, oats, malt, oysters, firewood and household goods. In return, London sent a great diversity of products, notably dyestuffs, soap, oil, groceries, ironware, glass, earthenware, tobacco, wine and exotic goods (*ibid*, 86; Willan 1938, 100, 204).

Large amounts of coal and salt were shipped from Newcastle and Sunderland to Colchester in exchange for wheat and rye. Nearly all the east coast ports, including London, supplied Colchester with raw wool for the cloth industry. Fuller's earth, for cloth processing, came mainly from Rochester and Faversham in Kent, and pipe clay for the clay-pipe industry came from Poole in Dorset (*VCHE*, 9, 86-7; Willan 1938, 136). Direct trade links with the Low Countries remained important. Many Continental goods were funnelled through the Low Countries, and through Rotterdam in particular, to Colchester. These goods included a variety of Continental cloths, foodstuffs and manufactured items, among them stoneware pots from Germany, and Dutch earthenware, pantiles and bricks. Colchester functioned as a centre for the consumption and redistribution of Dutch merchandise, much of which it shipped to London and neighbouring ports (*VCHE*, 9, 84-5). Some direct trade with Norway, France and the Iberian peninsula was maintained, but it was always over-shadowed by the trade with London and Rotterdam.

The cloth industry declined in the 18th century and was stagnant by c 1750. Among the numerous shop-keepers and entrepreneurs in the High Street at this time were two Staffordshire potters who acted as agents for the shipping of Staffordshire wares via Hull and Gainsborough (see p 251). The town was slow to industrialise, but did become a centre of engineering in the later 19th century.

### Earlier work

The earliest possible reference to post-Roman pottery from Colchester was in 1779, in a note published in *Archaeologia* by Edward King (King 1779). In this, one of the earliest references of its kind in the country, King reported on a discovery made by a workman near Colchester in 1776 of about 30 curious earthen bottles 'of coarse red earth' which he called 'lachrymatories', possibly believing them to be watering-cans. He did not attempt to date them, but the illustration provided shows a gourd-shaped vessel with a

long narrow neck, resembling a Martincamp flask (imported from Normandy in the 16th to 17th century). However, Philip Crummy (pers comm) believes that these are more likely to be Roman, as 'lachrymatories' are often referred to in old records describing the contents of Roman graves.

From at least the 1870s, items of medieval and later pottery were acquired by Colchester Museum. These acquisitions increased in frequency as Victorian building projects gathered pace. The building of the new Town Hall in the High Street in 1899 and the Wyre Street Arcade in 1930 added large numbers of whole vessels to the museum collection. From 1903 onwards, descriptions and sometimes photographs of these 'Bygones' appeared in the Museum reports.

Two substantially complete vessels in Thetford-type ware were found in the High Street in 1936 and reported on in the Museum reports (*CMR* 1935-7, 45). John Hurst included these vessels in his survey of Thetford-type ware published in 1957 (Hurst & West 1957, fig 6.1-2). More Thetford-type ware was identified by John Hurst in material from a late Saxon pit found in 1955 when St Nicholas' Church was demolished and a small excavation was carried out by M R Hull (Hull 1960, 301-328).

The first significant descriptions of late medieval and post-medieval pottery from Colchester were published in 1961 by John Hurst, who described an assemblage from excavations in West Stockwell Street which included Colchester-type ware associated with a sherd of Spanish lustreware and several post-medieval imports from other contexts (Hurst 1961a). The following year an important description of early medieval pottery from the Norman bank of Colchester Castle was published by G C Dunning based on material from excavations carried out in 1950 (Dunning 1962).

Still within the borough, though located two miles north of the town, road-widening and gas-pipe laying schemes in 1973 led to the discovery of late 12th- to 13th-century and

14th- to 15th-century kiln-sites at Mile End and Great Horkesley respectively (Drury & Petchey 1975), the types of pottery produced at these kilns being the dominant medieval coarsewares of Colchester and the surrounding area.

In more recent years, Philip Crummy has published a wide sample of Anglo-Saxon and early medieval pottery from the town, much of it from the excavations between 1971 and 1977 by the Colchester Archaeological Trust and the rest from earlier excavations or chance finds (*CAR* 1, 140 *passim*). This still remains a valuable synthesis, particularly for the early Anglo-Saxon period. Another valuable report was provided in 1982 by Carol Cunningham, who described the medieval and post-medieval pottery from various excavations in the vicinity of Colchester Castle (Cunningham 1982a). In this report, medieval 'Colchester ware' is defined for the first time (*ibid*, 365), and wasters of slip-painted Colchester ware from the 15th-century kiln-site at Magdalen Street are described and illustrated. A description of the seven or so early medieval kilns from the Middleborough site was published by Philip Crummy in 1984 together with a summary by Carol Cunningham of the pottery produced there (*CAR* 3, 186-9). In the same volume Carol Cunningham provided an appendix on Colchester ware louvers illustrated with examples from Colchester and Chelmsford (*ibid*, 211-14).

Work on the present volume was begun in 1984. Most of the text was written between 1987 and 1989. The introductory section and conclusions were written in 1994-5 and, at the same time, most of the fabric sections — particularly the local wares — were extensively revised and updated. Appendix 3 (neutron activation analysis) was written in 1996. The majority of personal communications (pers comms) cited in this report were made within 1990-95. A few pers comms which are older than this (date provided) have also been retained where there was no reason to suppose that the opinion given would have significantly changed.

## Chapter 2. English wares: early to mid-Saxon (c 450-850)

### Saxon 'brickearth' fabrics (Fabric 97)

[Fig 5.1-3]

Weight: 2.475 kg

Number of sherds: 178

EVEs: 1.67

Fabric 97 is a catch-all term for a heterogeneous category of early to mid-Saxon pottery presumed in the main to be locally produced, and with a basic 'brickearth' fabric with varying amounts of sand and grit tempering. This excludes the more obviously vegetable-tempered 'brickearth' (Fabric 1) which tends to be sand-free.

The code Fabric 97 was devised to facilitate the basic recording of 'brickearth' fabrics, pending more detailed examination. It thus corresponds to Fabrics 2-4 in the system devised by Carol Cunningham for the recording of post-Roman pottery in Essex (Cunningham 1985, 1-4) and elaborated for the Saxon wares at Heybridge (Drury & Wickenden 1982). In the event, due to the many subtle variations and hybrids observed, a detailed quantification by fabric sub-groupings has been avoided, although some of the more significant variations will be indicated.

Philip Crummy (*CAR* 1, 1-24) has brought together all the available information on early to mid-Saxon pottery in Colchester up to that date. This included most of the pottery under consideration here. Although there is little to add to this earlier discussion, the material from the excavations of 1971-76, as well as from the excavations up to 1985, is here fully quantified for the first time. Some more recent material may also be discussed and some recent views on these fabrics may be aired.

The bulk of Fabric 97 comes from residual or ambiguous contexts, mostly as isolated, generally small body sherds. However, over one-third of the fabric came from a 5th-century Saxon sunken hut from Lion Walk (Hut 2, Stratified Group 1; see pp 309-10), and a much smaller quantity came from another hut at Lion Walk, this time of the 6th/7th century (Hut 1, *CAR* 1, 1-5; see also p 311).

In the main, Fabric 97 comprises a hand-made 'brickearth' fabric, generally quite hard (not easily scratched with the fingernail), reduced and with a burnished outer surface, sometimes burnished on the inside as well. Vessels were probably fired in simple bonfire kilns. Most vessels were reduced to an even black or dark grey-brown colour, but the outer surfaces of some vessels have brown, weakly oxidised patches.

There is considerable variation in the nature and frequency of material added to temper the basic 'brickearth' fabric or perhaps occurring in it naturally. Such variations are suggestive of sporadic and small-scale potting activity mainly aimed at producing domestic vessels for individual households. No definite examples of funerary pots in this fabric have been found in Colchester (for these see Fabric 1).

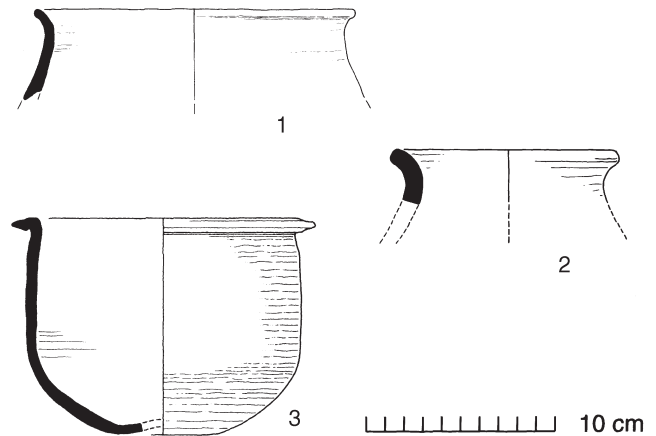

Fig 5 Saxon 'brickearth' wares (nos 1-3). 1:4.

Many of the fabric variants must have been contemporary; the earliest Saxon hut from Lion Walk (Hut 2, 5th century) produced at least seven variants of this fabric in addition to a few vegetable-tempered sherds. These variants include fine, well-made vessels with walls as thin as 3 mm in places, as well as coarser vessels with walls of up to 9 mm thick.

A small number of vessels from the excavations (six sherds) occur in a fairly pure, untempered, soft 'brickearth' fabric (Fabric 2). Around one-fifth (18%) of the assemblage has a sand-free or relatively sand-free fabric with varying amounts of calcareous inclusions (Fabric 4C). These inclusions vary in size from around 0.25-2.00 mm but are generally below 1 mm. Sometimes these are abundant (usually fine) and evenly distributed through the fabric but more often their presence is moderate and more sporadic (as in Fig 5.1). Where structure is visible, the calcareous inclusions appear to be finely crushed fossil shell and spherical chalk fossils or oolite. Oolitic limestone does not occur in Essex, but small amounts may have arrived in glacial deposits (Hunter 1979, 232). Often the shell has been dissolved away from the inner surface of the vessel leaving tiny voids. This probably occurred during the cooking of foods with some acidic content. Just as isolated calcareous inclusions may occur in sandier brickearth fabrics, small amounts of coarse angular quartz, earthy haematite, clay pellets, fine mica, coarse flint and even rare vegetable matter may occur in both calcareous and sandier fabrics.

The great majority of Fabric 97 occurs with a sand or quartz grit tempering (Fabric 3) corresponding to many similar 'grit'-tempered wares in southern England (Vince 1984, 431-2). Some of these vessels had a surprisingly fine fabric with relatively little fine sand, but generally vessels have a grittier fabric with moderate to abundant coarse angular

quartz grits up to 1 mm across. A few very coarse vessels have angular quartz grits between 1.0 and 2.5 mm with rarer sub-angular flint up to 4.0 mm (Fig 5.2, and a dish/shallow bowl from Hut 2 (CAR 1, fig 5.7; 5th century). Likewise a few vessels occur in an almost medieval-looking, uniformly sandy fabric with sub-angular quartz between 0.25 and 0.50 mm (also Hut 2).

One atypical vessel (Fig 5.3) appears to be wheel-turned or wheel-finished. In most cases, small body sherds from wheel-thrown vessels can be discounted as residual Roman material; however, in this case, where the vessel is reasonably complete and a Roman identification has been ruled out, it does appear to be a genuine instance of a sub-Roman or Anglo-Saxon wheel-turned vessel. It may be that the vessel is a regional or even a Continental import, but unfortunately it cannot be firmly identified and its archaeological context is of limited use for dating. For the present, it has been accommodated under the Fabric 97 code. The vessel (unstratified) came from Balkerne Lane, which produced almost entirely Roman and post-medieval deposits. Almost the whole pot was recovered. The fabric is hard, dark brown and sandy with a moderate scatter of coarse platy, shell, and limestone or chalk inclusions. The inner and outer surfaces are black and burnished in a horizontal direction, but much more random than on Roman pottery, and there is a white deposit on the inside. Despite its superficial resemblance to Roman forms, this is not considered to be a Roman vessel (Robin Symonds, pers comms), nor is it likely to be a Continental import although it could be a sub-Roman (5th-century) product (Mark Redknap & Nigel Macpherson-Grant, pers comm).

Philip Crummy (CAR 1, fig 5.5,7,8,9,11,12 & fig 7) has illustrated most of the more complete profiles and decorated pieces from the Anglo-Saxon huts and other contexts in the town found before 1980. Eight other plain vessels are illustrated by Dunnnett (1966, fig 12.22-9). The commonest forms are the jar (Fig 5.1 & 2) and the deep biconical bowl (CAR 1, fig 5.8 & 12). Both tend to have simple tapered or slightly thickened out-turned rims, almost 'cavetto' in profile. Thus it is difficult to distinguish the vessel form from the rim-herd alone, although the bowl rims may be more thinly potted. Figure 5.1 could therefore be from a bowl rather than a jar.

Excluding the wheel-turned jar and unusual or rare forms (eg dishes), an analysis of rim diameter from 20 vessels, from both earlier and recent excavations, reveals a diameter range of around 100-230 mm. There is an even spread of vessels between 100 and 160 mm except between 110 and 120 mm which was clearly the preferred size in this lower range (five vessels). Most of these are probably small globular jars, although one deep biconical bowl is present in this range (130 mm; CAR 1, fig 5.8). Another clear size preference is shown at 180-200 mm (eight vessels). The majority of deep biconical bowls belong to this higher range, but a few definite jars are also represented (eg CAR 1, fig 5.9). One vessel, if not distorted, could be as wide as 250 mm.

Bases of all vessel forms are predominantly flat, but not markedly so. Some have steeply flaring lower walls and a markedly flat, almost pad, base (not illustrated). Pedestal-footed bases such as occur on some biconical bowls (eg Hurst 1976, fig 7.3, no 1) have not been recognised at Colchester.

Rarer Fabric 97 forms include shallow bowls or dishes with flared or gently curved walls (CAR 1, fig 5.7). At least four of these have been found, three from a single Anglo-Saxon pit on North Hill (Dunnnett 1966, figs 12, 25-6, 28), the last of which is unique for its crudely hemispherical, slightly shouldered form. A smaller dish from Culver Street (1.81 GL1746; not illustrated) has a plain rim with a diameter of only 90 mm, and is in an untempered 'brickearth' fabric (Fabric 2). As this is sooted underneath, it could be a lamp or less likely a crucible or a heating tray (cf CAR 5, fig 96). A small bag-shaped vessel from North Hill has been described as a crucible (Dunnnett 1966, fig 12.22), but could equally be a lamp. Two rims from an earlier excavation on North Hill come from unusual, possibly gourd-shaped vessels with plain inward-sloping rims (CAR 1, fig 7.4-5).

The majority of jars must have served as cooking vessels. Several have sooty deposits on the outside, including a shoulder sherd from a biconical bowl. Large unsooted vessels, such as one from an Anglo-Saxon hut (*ibid*, fig 5.9; Hut 2), could have served as storage jars or water containers despite the resemblance of the latter to medieval cooking pots. Except for burnishing, the great majority of vessels are plain, although several decorative techniques may be seen. Three sherds, from as many vessels, have deliberately rusticated exteriors (*schlickung*), whereby a thin coat of lumpy clay and calcite grits was smeared over the surface of the vessel (LWC E12, LWC KF17, 1.81 JL1). Two of these have a calcareous-tempered fabric, while the third is sandy and comes from a wide flat-based vessel carefully burnished inside. Incised horizontal grooves on the shoulder and burnished horizontal lines giving a corrugated effect are probably the commonest form of decoration (CAR 1, fig 5.11-12). Oblique incisions occur on the shoulder of another vessel (*ibid*, fig 7.3), and one sherd has traces of what seems to be incised concentric circles (LWC KF59; not illustrated). One biconical bowl has a band of faceted, pyramidal studs or bosses at its widest point (*ibid*, fig 5.12), and another has vertically elongated bosses covered with deeply incised lines (LWC KF47, as *ibid*, fig 5.6 & Hurst 1976, fig 7.5, no 5). At least one vessel, burnished on both sides, has widely spaced, vertically elongated dimples (LWC E12; not illustrated).

## Dating

The evidence for this has already been discussed by Philip Crummy (CAR 1, 5-6, 22-3). This evidence has not radically changed but, in the light of fuller statistical information and more recently published parallels, a revised summary may be presented here.

Anglo-Saxon 'brickearth' fabrics (Fabric 97) exhibit stronger typological and decorative links with Continental Germanic forms than do the other early-mid Anglo-Saxon wares from the town (Fabrics 1 & 12D). The pottery from Hut 2 at Lion Walk (Stratified Group 1) is undoubtedly the earliest collection of post-Roman pottery from the town and consists predominantly of Fabric 97 (93% by sherds), the rest being vegetable-tempered ware (Fabric 1). Philip Crummy cautiously preferred to see Hut 2 as post-dating the collapse of Roman Colchester c 440-50, particularly as the hut had been dug through the floor of a Roman house (CAR 1, 22). Elsewhere, however, notably at Heybridge in Essex, very similar assemblages from Saxon huts have been dated to early in the 5th century (Drury & Wickenden 1982). Similar

assemblages from Anglo-Saxon huts at Mucking, Essex are dated more generally to the 5th century (eg Hamerow 1993, Grubenhuis 17, fig 93). Arguments for a pre- or post-c 450 date for Hut 2 are unlikely to be resolved until further huts of the 5th century are found in Colchester, preferably in association with better-dated finds.

At Mucking, faceted carinated bowls and biconical forms (in fabrics corresponding to Fabric 97) were mainly a 5th-century phenomenon (*ibid*, 42, 44). The use of coarse slip or *schlickung* at Mucking was also predominantly 5th century, and vessels treated in this way were large storage jars rather than cooking pots (*ibid*, 37, 54). One of the *schlickung* sherds from Colchester (LWC E12) is from a wide, flat-based vessel and, like the Mucking sherds, it is also carefully burnished on the inside. Such parallels appear to confirm a predominantly 5th- to 6th-century date for Anglo-Saxon 'brickearth' fabrics from the town.

The difficulty with undiagnostic and undecorated sherds of Fabric 97 is that they are impossible to date closely even when the rim or base is present. Close dating is only possible when associated with other datable artefacts. A small amount of Fabric 97 (18% of hut assemblage), mostly body sherds and plain everted jar rims, was found in the first Anglo-Saxon hut found at Lion Walk, and which is dated by other artefacts to the 6th/7th century (Hut 1: CAR 1, 1-5). The simple forms present show no typological development from the 5th-/6th-century forms.

Because vegetable-tempered ware (Fabric 1) is already the dominant local fabric in Hut 1 (6th/7th century), and because it is the only fabric present in a third hut of the 7th century (Hut 3, Stratified Group 2), it seems reasonable to surmise that Fabric 97 gradually went out of production during the 7th century.

### Saxon vegetable-tempered ware (Fabric 1)

[Fig 6.1-6, Fig 207.1-3]

Weight: 7.345 kg

Number of sherds: 455

EVEs: 5.05

Vegetable-tempered pottery occurs in all three or four Anglo-Saxon sunken huts in the town and in the post-Roman 'dark earth' layer which represents cultivation during the Anglo-Saxon and early medieval periods (CAR 3, 92). Most excavations in the town produce a sherd or two of this ware, which is normally residual. This type of hand-made pottery is common over much of England and is highly characteristic of early Anglo-Saxon domestic pottery (Hurst 1976, 294). It remains as the dominant fabric in Essex during the mid-Saxon period and may have continued in production into the start of the late Saxon period (c 850-1050), albeit on a much reduced scale.

### Fabric

Most specimens have a relatively sand-free 'brickearth' fabric which is barely scratchable with a fingernail. There is usually some mineral content, however slight, often in the form of rare and coarse quartz or flint grits. But the dominant inclusion is an added temper of coarsely-chopped vegetable matter — grass, straw, chaff and possibly dung. This usually burns out leaving a laminated, pitted or corky texture and frequently clear impressions of grass stems and seeds. Firing took place in simple bonfire kilns producing a

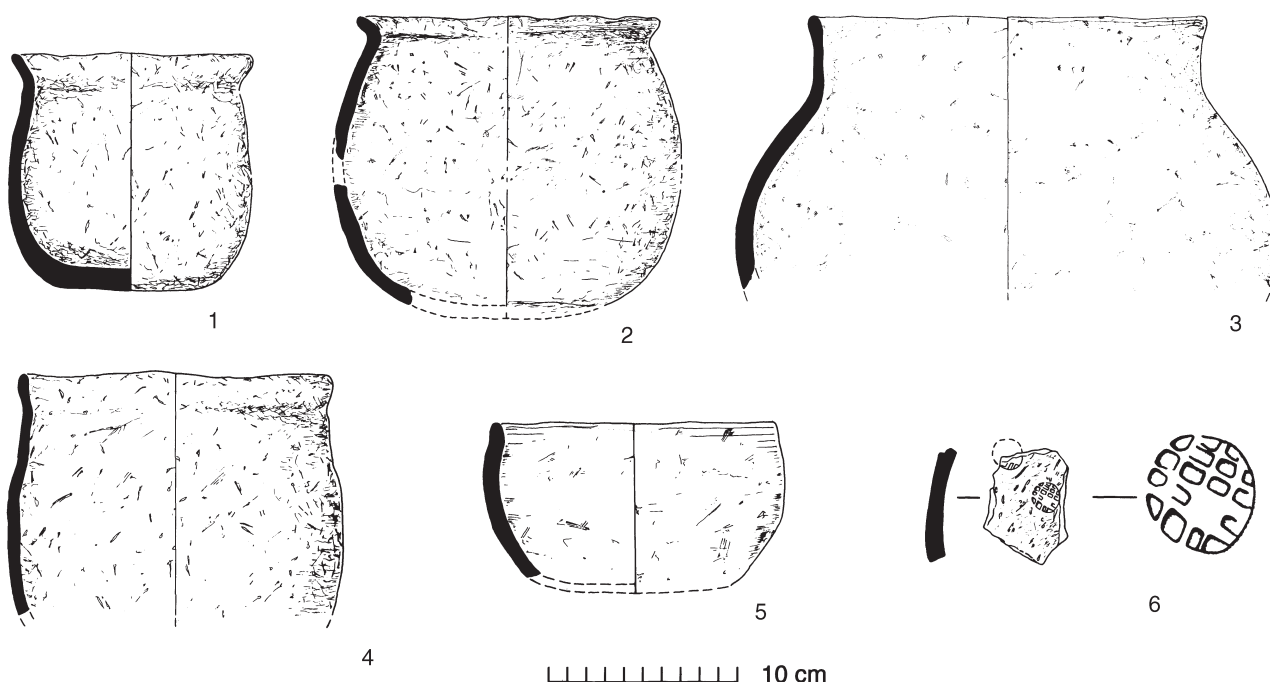

Fig 6 Vegetable-tempered ware (nos 1-6). 1:4. Stamp detail (no 6) at 1:1.

reduced dark grey or grey-brown colour, sometimes with lighter grey or even weakly-oxidised patches. External burnishing is common, sometimes extending to the inner surface of the rim; there is only a single possible example of a vessel burnished on both sides. The thickness of vessel walls varies from 4 to 13 mm. Three fabrics occur in Essex (cf Drury & Wickenden 1982, 13). These, simplified, are as follows:

- 1A. Vegetable tempering only ('early Saxon')
- B. Hard, vegetable tempering only ('mid-Saxon')
- C. Vegetable and sand tempering.

Except in a few special circumstances (see Stratified Group 1), the vegetable-tempered wares from Colchester were not examined or quantified in much detail, but it is possible to say that the dominant fabric appears to correspond to Fabric 1B, a hard fabric with much vegetable tempering and little or no sand. All three fabrics, however, are represented.

## Forms

Most of the more complete or decorated forms from the town have already been discussed and illustrated by Philip Crummy (*CAR 1*). These consist mainly of baggy, globular or ovoid jars with plain or slightly thickened and gently everted rims (*ibid*, fig 6.1-2, 4; see also Stratified Group 2, Fig 207.1-3). Bases, where present, are flat and poorly defined. A few larger examples have a cylindrical neck with a slightly everted rim (Fig 6.3). Most vessels are fairly crude with uneven surfaces and considerable variation in rim thickness on the same vessel (eg Fig 6.4). Taking all excavated examples into account, the rim-diameter range for jars is 90-230 mm with the great majority evenly distributed between 90 and 160 mm, with 90-95 mm being perhaps the most favoured size (four vessels out of a total of 22). Only two vessels (including Fig 6.3) are as large as 210-230 mm. A cremation pot from the Meanee Barracks and three other probable funerary vessels from the Mersea Road cemetery (*CAR 1*, figs 17 & 20.13-15) have markedly smaller diameters (110 mm) compared to the majority of vessels from more recent excavations. This may relate to the funerary function of the smaller vessels as opposed to a domestic function for the rest. Sooting on both sides of vessels is common. Heavy internal sooting and even carbonised matter was found on the insides of some of the vessels from Hut 3 (Stratified Group 2, see pp 310-11) and from the mid-Saxon activity on the site of a late Roman grain-drying oven (see below). This shows their use as cooking vessels, though others (as Fig 6.3) could have been used for storage or cooking.

Only one definite bowl is known in this fabric; it is small and hemispherical with a plain rim, and is burnished on the outside (Fig 6.5; see also *CAR 1*, fig 5.10). A bossed sherd from the 5th-century sunken hut (Hut 2, Stratified Group 1) could be from a biconical bowl (*CAR 1*, fig 5.6). There is a single rim sherd with a vestige of a crude, spout-like projection (not illustrated; 1.81 HF327), possibly a lamp (cf Mucking example in Hurst 1976, fig 7.3, no 9).

## Decoration

Except for burnishing, most vessels are extremely plain and decorated pieces are very rare. A bossed sherd with vertical grooves has already been mentioned (*CAR 1*, fig 5.6).

There are two stamped vessels. The first of these (*ibid*, fig 21.1), from the Cups Hotel site, is decorated with gridded, pear-shaped stamps, like tennis-rackets, and with horizontal and diagonal lines. Although quite small, the design on this can probably be reconstructed as a shoulder-frieze of pendant triangles with stamps both inside and outside the triangles. The stamps have been compared to those on a sherd of Ipswich ware from London (*ibid*, 19), but are better matched against the pear-shaped and other gridded stamps on a bossed biconical jar from a cemetery at Lackford, Suffolk and dating to the late 5th or early 6th century (Charleston 1976, pl 327). If not a derivative of this Illington/Lackford tradition, the Cups Hotel sherd could represent a genuine import from this area. There is a similar though undated vessel from Mucking (Hamerow 1993, fig 185.10) but, as it occurs in a sandy 'brickearth' fabric, it probably dates to before the 7th century. The second stamped sherd is from Culver Street Site C. It is thick-walled and faintly burnished with two circular gridiron stamps (Fig 6.6). It may be derived from the 7th-century sunken hut on the adjacent Site B (Stratified Group 2) but, unlike the vessels from this group, it has a distinctly sandy texture. Circular, gridiron stamps are common on Saxon pottery from the early Saxon period onward. As there is no trace of a linear pattern on this sherd, the design is probably random. Random stamping is generally put relatively late in the sequence of pagan Saxon pottery, so that a mid 6th- to mid 7th-century or an even later date could be suggested for this example (Catherine Hills, pers comm, 1986).

Two other sherds occur with vertically-elongated dimples (not illustrated; CPS F95 & LWC EF10), and one of these is unusually thick-walled (12 mm).

## Discussion and dating

Without associated artefacts and lacking decoration, it is impossible to date most of these plain wares any closer than their generally accepted range from the 5th to the 7th or 8th centuries. At Mucking, vegetable ('grass')-tempered pottery is present in the 5th-century sunken huts, but generally forms only 5-27% of hut assemblages of that date (Hamerow 1993, fig 17). A marked increase in the use of vegetable-tempered ware occurred at Mucking in the 6th and 7th centuries as shown in the 7th-century huts which produced 74-97% vegetable-tempered ware. A similar picture emerges from the three Saxon huts at Colchester (see below).

Typological developments noted in the vegetable-tempered forms at Mucking were few. Rim curvature becomes less marked through time so that rims become progressively shorter and more upright (*ibid*, 44). 'Straight-sided' ovoid jars also come into their own in the 7th century (*ibid*, 44 & fig 27). A number of the Colchester jars would seem to fit this last category including Figure 6.1 and 4 and one of the jars from the Mersea Road cemetery (*CAR 1*, fig 20.15).

The single hemispherical bowl (Fig 6.5) could be quite early. It came from topsoil over a Roman road ditch on Lion Walk Site E, a factor in itself suggestive of an early date. This form has close parallels at Heybridge dated to the early 5th century (Drury & Wickenden 1982, fig 7, 29, 46 & fig 8.57), but only one of these is vegetable-tempered. It is probably significant too that the Lion Walk bowl was found only a few metres from a 5th-century sunken hut (see below), from

which it could have derived. The fabric is hard, sand-free and densely vegetable tempered.

Apart from these isolated instances there are only four contexts in the town in which vegetable-tempered pottery occurs with any useful associations and/or in any quantity. These in rough chronological order are:

1. Lion Walk — Saxon sunken Hut 2  
(Stratified Group 1, see pp 309-10).

Five vegetable-tempered sherds (7% of hut assemblage) came from this 5th-century sunken hut. Dating evidence rests exclusively on their association with distinctive forms in Anglo-Saxon sandy brickearth fabrics (Fabric 97), including round-bottomed biconical bowls datable as early as the first quarter of the 5th century, although in this case not necessarily quite so early. The vegetable-tempered sherds display three fabric variants, two of which are notable for their fine calcareous inclusions, a characteristic not found in later groups of this ware. One sherd is decorated in typical early Anglo-Saxon style with a vertically-grooved boss (CAR 1, fig 5.6). The other sherds consist of a probable flattened base and three body sherds.

2. Lion Walk — Saxon sunken Hut 1 (CAR 1, 1-5).

Pottery from this hut was predominantly vegetable-tempered (82% of hut assemblage). Associated finds were an annular loomweight, a fragmentary bone comb and a spindlewhorl (*ibid*, fig 5.2-4). None of these items are datable closer than the 6th or 7th century. The vegetable-tempered pottery consist of plain burnished sherds including three plain everted jar rims (*ibid*, fig 5.1). The fabric was sand-free and heavily vegetable-tempered.

3. Culver Street — Saxon sunken Hut 3  
(Stratified Group 2, see pp 310-11).

This is the largest assemblage (234 sherds) of vegetable-tempered pottery from the town, accounting for just over one-half of the total number of sherds excavated in the town. Hut 3 contained only vegetable-tempered pottery in addition to a fine bone comb and a ring-headed pin which indicate an early 7th-century date for the group. Several substantially complete jar profiles were recovered including a whole reconstructible small jar (Fig 6.1). By themselves, the forms are not capable of close dating, and the variety of shapes and wall-thicknesses shown by the pots from this one hut illustrates the problems of dating by form alone. All the sherds have the same hard, sand-free and densely vegetable-tempered fabric as in Hut 1.

4. Culver Street Site K (1.81 KF12) — late Roman grain-drying oven (CAR 6, 108-112).

This multi-flued structure was constructed of used Roman brick bonded with clay. There can be little doubt as to its late Roman date but, most unusually, it appears that the structure was used in the mid-Saxon period in a way not entirely unrelated to its original function. The evidence for this is the presence of two, possibly three, Anglo-Saxon vegetable-tempered vessels (Fig 6.2 & 4) present as fairly large sherds scattered through the ashy stokepit fill and interior. Examination of wheat grains from the ashy soil has shown it to be of the free-threshing variety commonly used in the Anglo-Saxon period. Both vessels were sooted on the outside, and Figure 6.4 also had a thick lumpy carbonised deposit on the inside which may be food residues. Exactly what the nature of this Anglo-Saxon activity is not understood, nor why they should choose this Roman structure as the focus of this activity. Possibly the oven, though a century or two old, was still intact enough to be used for its original grain-drying function, or perhaps Anglo-Saxons prepared and baked bread here. It is tempting to see a 5th-century link between a sub-Roman community and the newly arrived Saxons but, although vegetable-tempered ware is present by the 5th century, the total dominance of this fabric at this site is more compatible with a later date. The vessel forms too are entirely in keeping with a 6th- or 7th-century dating (Helena Hamerow, pers comm, 1987).

The absence of excavated features in the town securely dated to the 8th-10th centuries makes it impossible to say for how long this fabric remained in production. It appears that, during the 7th century, the dominant early Anglo-Saxon fabric in the town (Fabric 97) went out of use leaving vegetable-tempered ware as the major (and possibly the only) local pottery type in use. Middle Saxon pottery is extremely rare in Colchester, and to date only one (residual) sherd of Ipswich ware (c 725-850) has been identified, together with a handful of oolitic-tempered sherds, probably from Northamptonshire, and one or two Continental imports. If Ipswich ware had been present in Colchester in any quantity then, by association, it may have been possible to say something concrete about the presence (or absence) of vegetable-tempered ware during the period c 725-850, but unfortunately this is not the case. Other non-ceramic finds of this period are equally rare, and none comes from useful contexts. There is, however, one instance where a rim sherd of vegetable-tempered ware occurred in the same context as one other sherd tentatively identified as a North French import of the 8th or 9th century (Fig 174.2; Fabric 97F). The context (LWC A119) has been identified by the excavator as a layer of late Roman or early medieval topsoil over a Roman tessellated pavement. If the two sherds are contemporary (there is little sign of wear), then this would constitute important evidence for the continuation of vegetable-tempered ware beyond the 7th century. However, on the basis of this one association, it cannot be said that the matter is proven.

Elsewhere in the south-east, there was clearly some overlap between vegetable-tempered and Ipswich ware. At Ipswich itself, vegetable-tempered ware occurs in quantities too great to be entirely residual, and the same is true at Wicken Bonhunt in north-west Essex (Keith Wade & Catherine Hills, pers comm, 1987). One of the more exceptional vessels from Wicken Bonhunt was a spouted pitcher in vegetable-tempered ware from a 9th-century context (Hodges 1981, 56). This would appear to represent the latest convincingly-dated example of the ware in the county, and must have implications for its dating at Colchester. At London, the concurrency of vegetable-tempered and Ipswich wares has also been demonstrated (Vince 1984, 433). Vegetable-tempered ware is rare at the Treasury site in London which appears to date to the late 8th century or later, and in general the evidence from the City of London supports the view that the fabric had ceased to be used for domestic pottery by the late 9th century (Vince & Jenner 1991, 48).

The next major fabric to arrive at Colchester was Thetford-type ware (c 850-1150), probably coming from Ipswich. Elsewhere it is argued that Thetford-type ware did not reach Colchester in significant quantities much before the process of urban revitalisation in the 10th century, that is to say it was mainly imported after c 950 (see pp 31-2). The impression is that vegetable-tempered ware is defunct by this period, and indeed it is difficult to imagine this crude, hand-made fabric circulating alongside the quality, wheel-thrown wares of the Thetford-type industry. It is possible to point to two or three contexts which are dominated by Thetford-type ware (and thus are datable to the 10th or 11th centuries), but which also contain one or two sherds of vegetable-tempered ware (notably CPS F95 and Stratified Group 3). But it seems much more likely, given their low numbers and small size, that the vegetable-tempered sherds are residual elements in these contexts.

Philip Crummy (CAR 1, 17-19) has drawn attention to some examples of vegetable-tempered pottery from the town which may be later than the 7th century. None of these, however, came from contexts that did not also contain Thetford-type ware or later wares. Their tentative late dating

rests on individual variations such as greater sandiness, harder firing, lack of burnishing, or the presence of rim forms resembling early medieval (Fabric 13) rim forms. One sherd (*ibid*, fig 21.1) had a stamp similar to gridded stamps found on Ipswich ware. However, the case for their late dating remains unproven. Nearly all these individual variations can be paralleled in the four dated assemblages of this ware discussed above. The stamped sherd, as mentioned earlier, probably has more in common with East Anglian funerary vessels of the 5th and 6th centuries than it does with Ipswich ware. The similarity of simple thickened everted rim forms in vegetable-tempered ware with those in early medieval sandy ware must be ascribed to coincidence and their shared simplicity; the notion that vegetable-tempered ware overlapped in date with early medieval sandy ware (c 1025-50+) is even less likely than its overlap with Thetford-type ware in the previous century.

It can just be conceived that there may have been a brief period of concurrency in the mid 9th century between vegetable-tempered vessels and the first trickle of Thetford-type vessels reaching Colchester. If this was not the case, then there must have been a ?brief aceramic phase during the 9th century, during which time pottery ceased to be made locally for perhaps the first time since the Iron Age. The volume of finds in Colchester datable to the late 8th and 9th centuries is so low that Philip Crummy has suggested either that the town was deserted at this time or that its population had dropped to an all-time low (*CAR 1*, 72). In the light of this and of all the foregoing facts at least four possible explanations emerge as to why, in practice, vegetable-tempered ware at Colchester cannot be dated any later than the 7th century. This is because:

1. Typologically the late vegetable-tempered ware is indistinguishable from the earlier ware.
2. The lack of late Saxon contexts makes it impossible to date any local wares to this period.
3. The town was deserted during the late 8th and 9th centuries.
4. The town was occupied but aceramic during the late 8th and 9th centuries (or that the population had contracted drastically and pottery use contracted accordingly).

Of these, (1) and (2) are almost certainly true; either of (3) or (4) seem quite likely but are difficult to prove either one way or another. If we accept the pottery from the late Roman grain-drying oven as 7th century or earlier, then two-thirds of all the vegetable-tempered ware from the town can be assigned to the 7th century or earlier. Of the remaining third (156 sherds), at least some proportion must represent residual earlier material, so that the volume of vegetable-tempered pottery which possibly dates later than the 7th century is really quite low indeed. This strengthens the likelihood that either (3) or (4) of the above explanations actually happened and that, if Colchester was not wholly aceramic for a time, then it was very nearly so.

By c 917, the town had been reoccupied for some time by the Danes, until they were expelled in this year by Edward the Elder. Elsewhere in England the Viking presence had a curiously beneficial effect upon the late Saxon pottery industry (eg at Stamford, Lincolnshire; Kilmurry 1980, 195, 201-2), and with their trading connections and the proximity of Ipswich they would hardly have used vegetable-tempered wares when wheel-thrown Thetford-type ware could be obtained. But what impact the Vikings really had on pottery production at Colchester can only be guessed at.

## Ipswich ware (Fabric 8)

[Fig 7.1]  
 Weight: 0.030 kg  
 Number of sherds: 1  
 EVEs: 0.11

Ipswich ware has a hard, sandy, grey fabric. Vessels were built up by hand, finished off on a turntable (often to a high standard), and fired in proper kilns. It is these characteristics that set Ipswich ware apart from earlier and contemporary Anglo-Saxon pottery. The only known kilns are in Ipswich itself (Hurst 1976, 299-303). Recent research suggests that the dating of Ipswich ware should be revised to c 725-850 (Blinkhorn forthcoming).

Figure 7.1 is, to date, the only known Ipswich ware from Colchester (identification confirmed by Paul Blinkhorn). This is from a ?cooking pot with a plain rim. It is well fired and well made with a grey, sandy fabric and a smooth surface finish, thus corresponding to type (a) of the four fabric types that have been distinguished (Hurst 1976, 299). The lip of the rim is worn in a curiously regular fashion and sooting is present, mostly on the inside. This piece was found at the Cups Hotel site in the High Street where it was residual in a robber trench of c 1100-50 (CPS F116).

Confusion over the presence of an Ipswich spouted-pitcher fragment in Colchester Museum (CM 48.1973/6) has caused the premature inclusion of Colchester in a distribution map of the ware (Dunmore *et al* 1975, fig 33 as pointed out in *CAR 1*, 24 note 24). Unfortunately the alternative attribution to Bradwell is also mistaken, since the sherd in question was actually found at St Osyth's Priory, Essex (Hurst 1959, fig 5.2).

The complete absence up till now of Ipswich ware in the town has always been rather curious. It is still curious that there is so little of it, given the proximity of Ipswich itself, only eighteen miles away, and the fact that sites further down the Essex coast, such as Maldon, have produced much greater quantities of the ware (Carol Cunningham, pers comm).

Although of interest, the very minor presence of Ipswich ware in Colchester does not significantly alter the picture of the town as a place of comparatively little activity in the middle Saxon period (*CAR 1*, 72).

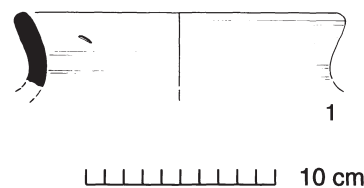

Fig 7 Ipswich ware (no 1). 1:4.



**?Mid-Saxon wheel-turned 'bottle' (Fabric 8V)**

[Fig 8.1]

Weight: 0.025 kg

Number of sherds: 1

The fabric is represented by a single sherd from the shoulder of a narrow-necked, wheel-turned jar or 'bottle' with incised wavy decoration on the outside (Fig 8.1). It has a dark grey, sandy fabric with some mica, and the surfaces are brownish, smooth and leathery. It was found in a robber trench of c 1000-1200 on the Cups Hotel site in the High Street, and was clearly residual in that context.

While the vessel is almost certainly of mid-Saxon date, opinion varies as to its identity. One suggestion is that it may be a Frankish import, perhaps a so-called 'Asthall-type' bottle (Keith Wade, pers comm, 1987; Evison 1979, 8-13), but the more favoured suggestion is that it may be an unusual variant of Ipswich ware (Paul Blinkhorn & Catherine Coutts, pers comm, 1987) similar in form and decoration to some unusual 'bottles' found in a kiln at Ipswich originally dated to c 800-50 (Blinkhorn 1989, fig 5.3-6), but now believed to date within the period c 725-850 (Paul Blinkhorn, pers comm).

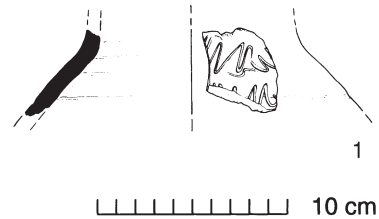

Fig 8 ?Mid-Saxon wheel-turned 'bottle' (no 1). 1:4.

**Oolitic wares (Fabric 12D)**

See early medieval shelly wares below, pages 37-9.

---

## Chapter 3. English wares: late Saxon and early medieval (c 850-1200)

---

### Thetford-type wares (Fabric 9)

---

[Figs 9.1-15, 10.16-19]  
Weight: 10.155 kg  
Number of sherds: 768  
EVEs: 8.47

These have a sandy, hard grey fabric made on the wheel. A range of textures and colour may be seen in the collection from Colchester:

1. A relatively fine fabric with a greyish-brown core and sparse black specks of magnetic iron oxide; the surfaces have a smooth, dark grey-black 'skin' on which the potters' fingerprints and other blemishes are often well preserved due to handling in the wet state.
2. A fabric with a coarser, sandier texture which may be uniformly grey-black throughout or display a single or double sandwich-effect section, grey-black margins enclosing a greyish-brown layer and a darker core; the surface is matt or slightly pimply.
3. A rarer dark orange-red fabric with dark grey-black surfaces.
4. Very rare completely oxidised pieces (accidental burning?).

No particular significance is attached to these variations in character, although they may in part reflect different production centres, whereas colour may simply reflect differing firing conditions.

Several locations in East Anglia have produced evidence for the production of Thetford-type wares, most notably in Norfolk at Thetford itself and Norwich, and in Suffolk at Ipswich (Hurst 1976, 314-20). Production of these wares continued for around three centuries between c 850 and 1150 with very little typological change. During this period, Thetford-type wares were widely circulated throughout East Anglia and south-east England.

### Vessel forms

By far the most common vessel type present is the jar, including plain jars or cooking pots, handled jars, storage jars and possible spouted pitchers. The only exceptions are four crucibles, two bowls and a costrel. It is reasonable to assume that all base fragments are also from jars. The following summary therefore relates only to jars.

Jars of various sorts in Thetford-type wares account for approximately 99% of all identifiable forms from the excavations. The diameters of jar rims range from 80 to 300 mm. These appear to fall into three approximate size groupings (by EVEs):

80-110 mm	14%
111-170 mm	73%
171-300 mm	13%

The most common single diameter is 160 mm (21%), and more than half of all jar diameters fall between 130 and 160 mm (54%). Of the bases (50 examples), 66% are flat (one-third of which are wire-marked), and 34% are sagging.

The typical Thetford-type jar found in Colchester is plain with an ovoid body and flat base. Almost without exception, rims are of simple flanged/everted form often slightly hollowed internally; the lip may be rounded, slightly flattened or sometimes bevelled externally. The commonest rim diameter encountered (130-160 mm) roughly corresponds to jars of 'medium' size (120-150 mm) at Thetford, where this is the commonest size of the commonest form (Rogerson & Dallas 1984, 120). The same appears to be true for Thetford-type ware from kilns at Ipswich (Smedley & Owles 1963, figs 70-74), and to a considerable extent at Norwich (Jennings 1983, 77-88). Twenty per cent of rim sherds at Colchester have girth grooves on the shoulder.

Large numbers of Thetford-type jars have been illustrated in recent Colchester publications (*CAR* 1, figs 32-34; Cunningham 1982a, fig 26.1-5). It is therefore unnecessary to illustrate more than a few typical examples here (Fig 9.1-7). Despite the absence of spout fragments from recent excavations, there can be little doubt that some of the handled rims are from spouted pitchers. Figure 9.8 may be a spouted pitcher or a handled storage jar. This piece is unique among the Colchester material on account of its plain, thickened, everted rim and the fineness of its fabric. An almost whole, two-handled spouted pitcher was found in 1936 at 30-31 High Street (*CAR* 1, fig 32.1; originally published Hurst & West 1957, fig 6.1). This was found with the small jar illustrated here (Fig 9.1). A second spouted pitcher fragment from the town has been published (Dunning 1961a, fig 10).

Rims with diameters in excess of around 170 mm are more likely to represent larger storage jars than the 'standard' jar or cooking pot. Storage jars are indicated by large and robust fragments, sometimes with applied thumbled strips for added strength (Fig 9.10-13). Figure 9.13 must have come from a very large vessel. The internal vertical shaving marks seen on this base, and many other large fragments, appear to have been caused by thinning the vessel walls with a convex-bladed tool. Such markings appear to be a characteristic of very large storage jars and have been observed on vessels from Thetford itself (Rogerson & Dallas 1984, fig 166.250).

Bowls are very rare, with only two examples known (Fig 9.14-15). Figure 9.14 is not closely paralleled and is quite similar to local Roman forms. Although a Roman identification for this bowl seems unlikely (Robin Symonds, pers comm, 1986), this possibility should not entirely be ruled out. The closest parallel for this is a much thicker bowl from Norwich (Jennings 1981, fig 4.88). The other bowl (Fig 9.15) comes from earlier excavations at St Nicholas' Church (see below).

Fragments of four possible crucibles have tentatively been

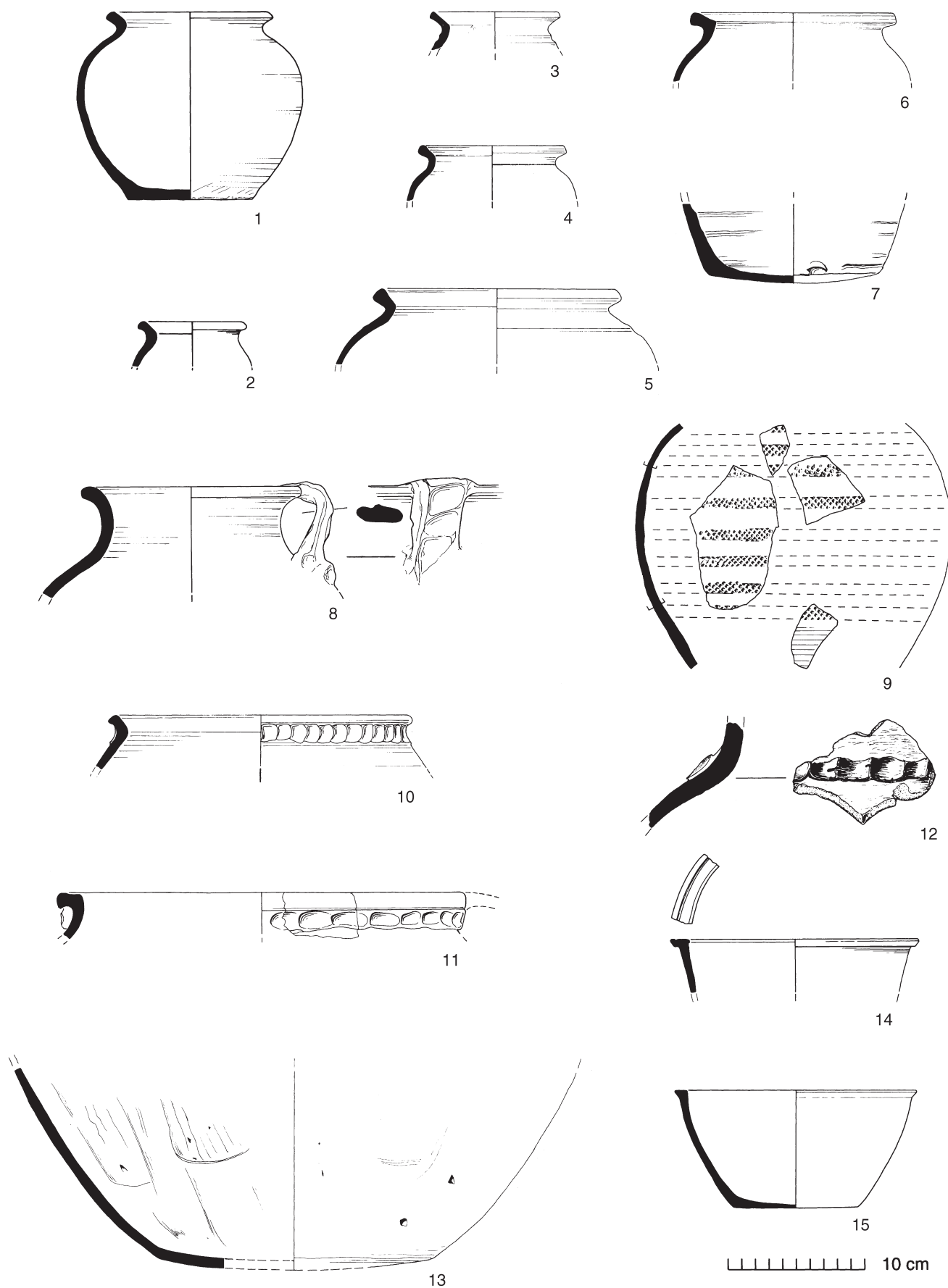

Fig 9 Thetford-type wares: cooking pots (nos 1-7); ?spouted pitcher (no 8); rouletted jar (no 9); storage jars (nos 10-13); bowls (nos 14-15). 1:4.

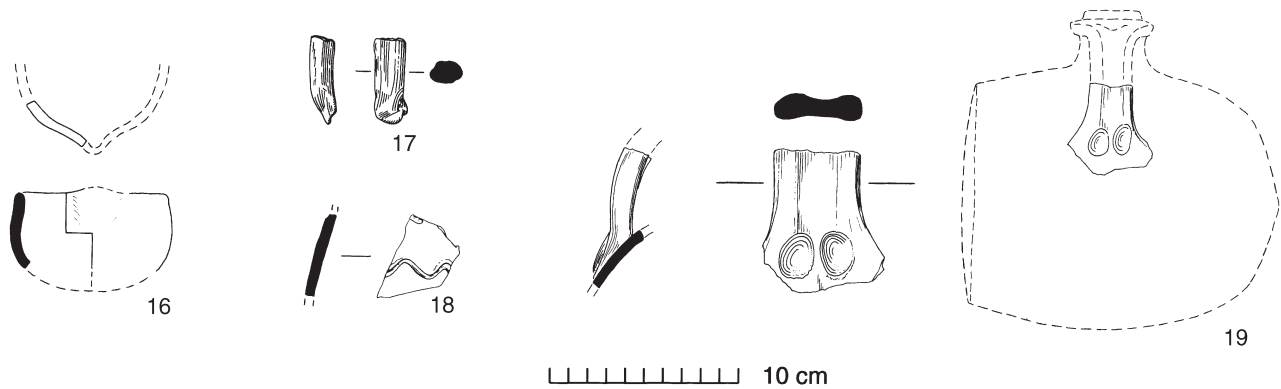

Fig 10 Thetford-type wares: crucible (no 16); miscellaneous object (no 17); combed sherd (no 18); costrel and reconstruction (no 19). 1:4.

identified as Thetford-type wares. However, due to the exceptionally high temperatures endured by crucibles and the effect that this had upon the vessel fabric, one cannot always be sure that the fabric has been correctly identified. All four were examined by Justine Bayley of the Ancient Monuments Laboratory, who concluded that only two had been used as crucibles. These include the crucible in Figure 10.16 (Period 2), which had slight traces of metal, suggesting it may possibly have been used to melt silver; the second crucible (LWC DF162) was represented by a body sherd with an added extra outer layer of less refractory clay. X-ray fluorescence detected slight traces of copper which had coloured the vitrified surface red. Despite the appearance of having a pinched-out lip, the remaining two vessels showed no other evidence that they had been used as crucibles. They may therefore have been lamps (LWC GF220, Period 2.3 & COC L69, Period 3.2).

Unique among the assemblage is a costrel fragment (Fig 10.19; Hurst 1976, fig 7.15, no 1). This is recognisable on account of its internal throwing lines which have a direction parallel to that of the vertical strap handle. Otherwise it would have to come from a large storage jar with a horizontal strap handle, which seems less likely. Another unusual item is Figure 10.17, a rod-like object flattened on one side where it was attached to something else. It may be part of an unusually high relief applied strip or a structural element from a large storage jar (eg *ibid*, fig 7.16).

### Decoration

The majority of vessels are plain unless the characteristic girth grooves are considered as decoration. Thumbled applied strips gave added strength to larger vessels but was clearly also used to some decorative effect. Colchester, however, has nothing to compare with the relatively complex strip decoration found on some vessels of this ware. Thumbled strips are vertical or somewhat diagonal in direction, while rarer horizontal strips occur below the rim (Fig 9.10-11) and, in one case, on the shoulder of the vessel (Fig 9.12). Most strap handles have a single thumbled strip running centrally down the length of the handle (Fig 9.8). Plain horizontal grooves occur singly below the rim of one or two jars and on the body wall of some storage

jars. A single body sherd (Fig 9.18) is decorated with incised wavy lines. The most highly decorated specimen of Thetford-type ware yet known from the town is a jar with multiple horizontal bands of lozenge roller-stamping (Fig 9.9). Towards the base, the surface of this vessel has been carefully shaved or smoothed in a manner reminiscent of burnishing on some Roman pottery, and the fabric too is somewhat finer and slightly more micaceous than usual, although it could still be Ipswich Thetford-type (Paul Blinkhorn, pers comm, 1987). The possibility that this piece might be Roman or a Continental import was investigated but deemed unlikely (Robin Symonds and Catherine Coutts, pers comm, 1987). Lozenge roller-stamping is not uncommon on Thetford-type wares from other localities, but normally occurs as a single band on the shoulder of the vessel. Although less common, multiple roller-stamping does occur on some jars at Ipswich (Smedley & Owles 1963, fig 70, d, f) and at Norwich (Jennings 1983, fig 41.153, 174).

Thetford-type wares from the High Street excavation at Angel Yard (1986-7) include at least two large storage jars with several circular gridiron stamps on the body and also on the raised areas of applied strips (40.86 F285 & F364; as Rogerson & Dallas 1984, fig 166.241).

### Distribution of Thetford-type wares in Colchester

Closer examination of material from sites excavated in the 1970s and material from sites excavated subsequently (up to 1987) has identified much larger quantities of Thetford-type wares in the town than was hitherto supposed. Despite some new dots on the map, the essential distribution pattern remains largely unchanged by this new evidence (*CAR 1*, fig 29). Outside of the Roman town wall, Thetford-type wares occur only sparsely and are entirely confined to the south-east, mainly from the grounds of St John's Abbey. The distribution is clearly an intramural one, with an emphasis along the principal thoroughfares of the town, particularly the High Street where the highest density of sherds occurs. Colchester's Roman town wall encloses a playing-card-shaped area roughly bisected along its long axis by the east-west running High Street. Most excavations in recent years have been located to the south of and set back from the High Street, between Culver Street and the town wall (Culver Street being parallel to and south of the High Street). In the Saxo-Norman period, these areas are

believed to have been arable land, and only sparsely populated. On the two major sites here, at Lion Walk and Culver Street, Thetford-type wares have a 'background' presence of around 0.22% and 0.23% respectively of all post-Roman pottery recovered. One of the sub-sites within this area (LWC J) has a much higher concentration of Thetford-type wares (1.64%), suggesting some activity here during this period. Sites fronting secondary roads running north and south from the High Street have also produced high concentrations of Thetford-type wares (eg 1.72% at Long Wyre Street). Towards the east end of the High Street, the Spendrite site had a concentration of 1.66% but, moving closer to the central section of the High Street (the political and commercial heart of Colchester), the amount of Thetford-type wares increases sharply to 6.03% of all post-Roman pottery recovered. This figure comes from the Cups Hotel site which lay next to the site of the Norman Moot hall (site of the present town hall). On the other side of the Moot hall, the site at Angel Yard also produced large quantities of the ware.

### Dating and origins of Thetford-type wares in Colchester

The Thetford-type tradition is generally dated to the period *c* 850-1150. Within this date range, however, the appearance and disappearance of the wares may have varied considerably from place to place. Thetford-type kilns at Norwich are dated to the later 10th or 11th century (Jennings 1983, 91), while those at Thetford seem to have been in production between the 10th and 12th centuries (Rogerson & Dallas 1984, 117, 126). Torksey-type wares, which are closely related to the Thetford-type industry, occur at York before *c* 900 though not in significant quantities (Mainmann 1990, 426-7). The earliest evidence for production comes from Ipswich, where the circulation of Ipswich Thetford-type ware in the mid to late 9th century can be demonstrated (Paul Blinkhorn, pers comm and forthcoming). Production of the ware could have continued at Ipswich as late as *c* 1100-1200 (Keith Wade, pers comm, 1987) and at Norwich possibly even as late as *c* 1200 (Jennings 1983, 91). At London, Ipswich Thetford-type ware is very rare before *c* 1025-1050 and may be intrusive. By *c* 1075-1150 the ware seems to be residual in London (Vince & Jenner 1991, 89).

Fifty-four per cent (by EVEs) of all Thetford-type ware from Colchester, not surprisingly, occurs in Period 2 (*c* 1000-1200). In Period 2.2-3 (*c* 1100-1150), the figure is 26%. No rims occur in Period 2.2-4 but, in Period 3.1 (*c* 1150/1200-1250/75), this figure has declined sharply to 5.5% and must represent residual material. Thetford-type wares comprise 46% of the assemblage in Period 2 (but only 13% by weight), 32% in Period 2.2-3, and 42% in Period 3 (*c* 1200-1400), but only 0.7% in Period 3.1.

Exactly when Thetford-type wares appeared and disappeared in Colchester is a question that cannot easily be answered. On historical grounds, they are unlikely to have been introduced before the expulsion of the Danes in *c* 917. This began the process of urban renewal with the layout of new street systems, and by 931 Colchester is referred to as 'a town well known to all men' (*CAR* 1, 24-5). By *c* 930-50 then, Thetford-type wares may have been reaching the town in some quantity. The continual use in the town beyond

*c* 1100-1125, however, seems unlikely. The difficulty in dating Thetford-type wares at Colchester lies in the great scarcity of contexts securely datable to the late Saxon period, coupled with the high degree of conservatism exhibited by Thetford-type forms and the degree to which sherds of the ware may or may not be residual.

There are three fairly certain late Saxon contexts in which Thetford-type wares are present:

1. St Nicholas' Church, High Street (*CAR* 1, 39). A group of nine fairly large sherds of Thetford-type wares (including the bowl Fig 9.15) was found in a pit on the site of the church in 1955. The apparent absence of early medieval sandy ware (Fabric 13) points to a date in the 10th or early 11th century. It is very rare for Thetford-type wares to occur in contexts that do not also contain early medieval sandy ware (or later wares). The two wares must have been contemporary for a time, as early medieval sandy ware probably appears in Colchester *c* 1025-1050, but it is difficult to determine to what degree the Thetford-type wares are residual in these contexts.

2. St John's Abbey. A small, late Anglo-Saxon church was excavated in the grounds of this abbey. The church was demolished *c* 1095 to make way for the Norman abbey (*CAR* 9, 213-15). The disturbed natural sand inside the church produced a sherd from the shoulder of a Thetford-type jar. Another sand layer associated with the church produced only early medieval sandy ware (*ibid*, 218). No Thetford-type wares were associated with the destruction of the abbey by fire in 1133 or found in contexts immediately post-dating the fire. However, the entire pottery collection from this site was quite small.

3. Stratified Group 3, the Cups Hotel site (CPS F106, p 311). This pit produced 77 sherds, 63 of which were Thetford-type ware and the rest early medieval and residual Saxon wares. A date of *c* 1000-1050 seems likely.

Philip Crummy has reviewed the evidence (up to 1981) for the dating of Colchester's Thetford-type wares (*CAR* 1, 32-40), so that it only remains here to summarise this evidence and add some new details. One of the Angel Yard stamped storage jars (40.86 F364) was found with a coin of Cnut (1016-1035), but as this context also produced a glazed sherd of Hedingham ware, it is unlikely to predate *c* 1150 at the earliest, unless the glazed sherd is intrusive. A small group of Thetford-type wares (four rims) from the 'tumble and robbing' context of the castle bank excavations has been argued to date no later than *c* 1000 (*CAR* 1, 40). Later groups from the castle bank, a mixture of Thetford-type and early medieval wares, are attributed on the basis of documentary evidence to *c* 1050-75. Although Thetford-type wares are absent from the lowest fill of the town ditch at Lion Walk, also dated *c* 1050-75 (Stratified Group 4), three small sherds do occur in the overlying fill dated *c* 1075-1100, but they could be residual. Five abraded sherds of Thetford-type wares came from the Period 1a pits and robber trenches (*c* 1100-1125) at Lion Walk Site G (see p 5). In the successive Period 1b contexts (*c* 1125-50), sealed by a 12th-century stone building, Thetford-type ware was entirely absent.

Evidence from the Cups Hotel site, which produced the largest collection of Thetford-type wares from the town, still shows Thetford-type wares comprising up to 27% (or 18% weight) of the 12th-century robber-trench assemblages (F112 & F116), but the levels of residuality at this site are likely to be higher than elsewhere in the town.

Although definite evidence for the local end-date for the use of Thetford-type wares may never be found, the impression gained at Colchester (and even more so from London) is that Thetford-type wares ceased to be used by c 1100-1125 if not before.

On geographical grounds the most likely source of the Thetford-type wares found in Colchester would be Ipswich, since this is the nearest known production site (Smedley & Owles 1963). Several typical jars illustrated here have been examined by Paul Blinkhorn (1987), who concludes that an Ipswich origin is likely. Figure 9.10, however, is unlikely to be an Ipswich product on account of its thumbled strip and gritty fabric. Other forms are more typical of Norfolk Thetford-type products, in particular the large storage jars. Figure 9.11 is exactly paralleled at Norwich (Jennings 1983, fig 39.105). Figure 9.12 has a coarser fabric similar to middle Saxon Ipswich ware, but the thumbled strip must date it to a later period (Paul Blinkhorn, pers comm). Large coarseware storage jars of this kind were produced in the 12th-century kilns at Sible Hedingham, and this alternative identification has not been ruled out. Convincing evidence of a Norfolk origin for at least some pieces is provided by the presence of the costrel fragment (Fig 10.19); this is a form known almost exclusively from Thetford (Rogerson & Dallas 1984, 121, fig 176). Costrels are extremely rare in Ipswich where there is no evidence of their production (Keith Wade, pers comm, 1987), likewise in Norwich (Jennings 1983, 90-91). Crucibles (Fig 10.16) and storage jars with circular gridiron stamps (see above) are also forms particular to Thetford (Rogerson & Dallas 1984, fig 175 & fig 166.241).

It is not impossible that an alternative source for Thetford-type wares may one day be discovered in Essex itself. Thetford-type wares from Wicken Bonhunt and from Sudbury near the Essex-Suffolk border do not have the characteristics of that from Ipswich (Keith Wade, pers comm, 1987). However, no evidence has been found to suggest that Thetford-type wares were ever produced at Colchester itself. Some general Thetford-style characteristics may be seen in the early medieval kiln material from Colchester at Middleborough and Mile End. These similarities are even more marked in the technically superior 12th-century coarseware products from the kilns at Sible Hedingham in north Essex. Material from these kilns could almost be classed as a sub-Thetford-type industry, particularly on account of its large storage jars and girth-grooved cooking pots, and its hard, grey fabric which closely resembles true Thetford-type ware.

Quite how (and if) the origins of the Hedingham ware industry relate to the Thetford-type industry can at present only be guessed. It has been suggested that undiscovered Thetford-type kilns may have been located at Bury St Edmunds (Suffolk), and that this late Saxon urban centre, rather than the rural Hedingham kilns, is more likely to have been the source of the unrecognised Thetford-type variants along the Essex-Suffolk border (Sarah Jennings, pers comm).

### St Neots-type ware (Fabric 10)

[Fig 11.1-4]  
Weight: 0.695 kg  
No of sherds: 56  
EVEs: 0.80

Next to Thetford-type and Stamford-type wares, St Neots-type ware is one of the best-known Saxo-Norman wares to have circulated in south-east England. Several detailed studies have been published (Hurst 1976, 320-23; McCarthy 1979, 156, 226-8; Hunter 1979, 230-40). St Neots-type ware is characterised by a fairly soft, almost sand-free fabric with a smooth or 'soapy' feel, and abundant coarse plate-like shell inclusions of fossil origin, including distinctive bryozoa which are common in Jurassic limestones. The core is dark grey while the surfaces are commonly pale or purplish-brown, although other tones exist. All vessels are wheel-thrown. In addition to the 'classic' fabric just described, a sandier fabric also occurs at Colchester which may be 'developed St Neots ware' (Hurst 1976, 323). This has many characteristics of the 'classic' fabric except that it contains common inclusions of quartz sand, both clear sub-angular and dark brown rounded grains. These are normally between 0.3 and 0.5 mm across. All the sandy sherds were examined under the microscope (at x20), but no fossil bryozoa was observed.

The distribution area of St Neots-type ware suggests its production at several points along the Jurassic limestone belt in the south-east Midlands, roughly along a SW-NE axis between Oxfordshire and Cambridgeshire (Hunter 1979, fig 105). It has been suggested that the source or sources of St Neots-type ware are the Oxford (Jurassic)

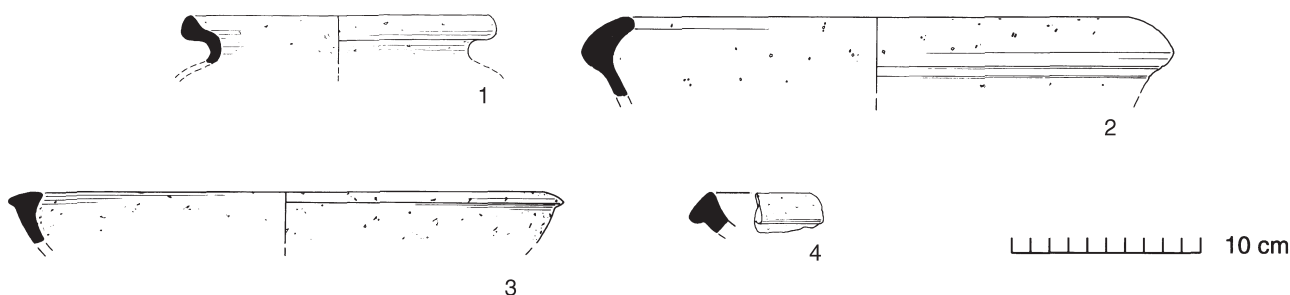

Fig 11 St Neots-type ware: cooking pot (no 1); bowls (nos 2-4). 1:4.

clay outcrops in Bedfordshire, Huntingdonshire and Cambridgeshire where the core distribution of the ware occurs (Vince & Jenner 1991, 55). Both the appearance and demise of St Neots-type ware cannot be dated with any great precision. It is known that the ware was in circulation by the late 9th century and enjoyed a floruit in the 10th century, but merged almost imperceptibly with local shelly ware industries during the 12th century (Hurst 1976, 323). Lying well to the south-east of the production area, it is hardly surprising that St Neots-type ware has only a minor presence at Colchester. In a major Roman settlement such as Colchester, difficulties exist in distinguishing body sherds, and even sometimes rim sherds, of St Neots-type ware from identical late Roman shelly wares (*CAR* 10, 458-63). Both industries must have been utilised the same clay sources along the Jurassic belt. (Late Roman shelly wares are known, for instance, from the Nene valley, well inside the St Neots-type ware distribution area.) It is now known, for instance, that a St Neots-type rim from Colchester published by Dunning is actually Roman (Dunning 1962, fig 2.2). Only a degree of familiarity with the forms found in both wares coupled with stratigraphic considerations will limit this confusion. However, the two most distinguishing characteristics of late Roman shelly ware at Colchester are that it has a fine external rilling and that vessels appear to have exclusively flat bases. Both of these features are rarely seen in St Neots-type ware.

A minimum of ten St Neots-type ware vessels occur in the 'classic' fabric, representing at least five cooking pots and three bowls. Cooking pot rims are either plain and everted, slightly thickened or flanged and hollowed internally (Fig 11.1). Bowl rims are either thickened and flat-topped, slightly inward-leaning with a short angular external flange, or sharply intumed (Fig 11.2). By weight and sherd number, the sandier fabric accounts for two-thirds of all St Neots-type ware, although a minimum of only eight or nine vessels is represented. Bowls are the only identifiable form in the sandier fabric, and these have a distinctive flat-topped rim form (Fig 11.4) possibly descended from the intumed rims. The greater percentage of this fabric taken together with its smaller minimum vessel number might suggest that vessels in the sandier fabric were larger than those in the 'classic' fabric, but it may simply be an anomaly caused by the recovery of a greater number of basal, and hence heavier, sherds.

None of the Colchester examples of St Neots-type ware occur in contexts securely datable before the 12th century. At the Cups Hotel site, sherds in the 'classic' fabric occur in contexts either with or stratigraphically later than sherds of Andenne ware (CPS F46, F83), and so only a broad general date of *c* 1000-1200 can be ascribed. In the series of robber trenches below the 12th-century stone house on Lion Walk Site G (see p 5), the sandier St Neots-type fabric occurs in a context of *c* 1100-1125 (LWC GF232). Several sherds from a cooking pot in the 'classic' fabric (Fig 11.1) were found with a Stamford ware pitcher, but in a post-medieval pit cutting the robber trenches. Like the pitcher, which joins sherds in the GF232 robber trench, the cooking pot is almost certainly derived from the same trench, and would therefore be contemporary with the sandier fabric. On the same site, only sandier St Neots-type ware occurs in a robber trench dated *c* 1125-1150 (LWC GF231), although it could derive from the earlier context. Later examples occur in Period 3.1 (MSC L25, L26), and other examples (LWC UF10, JF53) occur with Fabric 20

suggesting a late 12th- or 13th-century survival. The simpler, relatively restrained rim form found on the sandier bowls is paralleled by examples from Bedford from late 11th- to early 12th-century contexts (Baker 1974, fig 5.1-3).

St Neots-type ware appears, then, to have come relatively late to Colchester. Vessels in the 'classic' fabric may have arrived here in the 11th century to be replaced gradually by the sandier fabric in the 12th century, as happened in many other areas (Hurst 1976, 323). Forty-seven per cent (by weight) of all St Neots-type ware in Colchester occurs in Period 2.2 (*c* 1100-25). If we include sherd Figure 11.1, which as we have seen must be derived from a Period 2.2 context, this total can be revised to around 71% and St Neots-type ware would then comprise 7.7% of the Period 2.2 assemblage. However, it comprises only 0.1% of the assemblage in Period 2.

### Stamford ware (Fabric 11A)

[Fig 12.1-3]  
Weight: 0.410 kg  
Number of sherds: 55  
EVEs: 0.73

Stamford ware is characterised by a very fine, virtually untempered white fabric, although off-white and buff shades may also occur. The glaze is pale yellow or pale olive green and quite uniform in application. This high-quality ware was produced at Stamford in Lincolnshire at least by 900 and enjoyed a wide British circulation particularly in the 11th and early 12th centuries (Hurst 1976, 323-6; Kilmurry 1980). After the middle of the 12th century, Stamford ware was gradually succeeded by developed Stamford ware with a mottled green glaze. This type, however, has not been found in Colchester.

The only identifiable form present in Colchester is the two-handled jar (Fig 12.1). These may well be spouted pitchers (Kilmurry 1980, form 5, fig 52.68-86), although no spouts were found. Figure 12.3 is decorated with strong vertical fluting giving a segmented effect. One small sherd (CPS L22, not illustrated) may be decorated with short vertical notches, perhaps in groups (as Jennings 1981, fig 11.235), or forming a horizontal band. A single horizontal groove is the only other decoration present. Figure 12.2 is a typical Stamford pitcher handle. Perhaps Figure 12.1 is a third handle.

A minimum of around twelve vessels is represented. One other probable Stamford sherd comes from the earlier castle excavations (Cunningham 1982a, 362). The bulk of the collection (38 sherds) comes from two adjoining areas of Lion Walk (Site D and especially Site G). Here they occurred in robber trenches predating a 12th-century stone building (see pp 5-6). In one robber trench (LWC GF233), Stamford ware occurred with a coin of William I, lost *c* 1095, while a continuation of this feature (GF203) contained a coin of Henry I, lost *c* 1115. Both contexts have been assigned to the Period 1a complex on this site, dated *c* 1100-25. At least two vessels (six sherds) came from robber trenches on the Cups Hotel site, and one sherd

*Stamford ware (Fabric 11A)*

came from St John's Abbey, the only extramural site to have produced this ware.

By EVEs, half of the Stamford ware from the excavations occurs in Period 2.2, but this is probably a single vessel. The other half of this vessel comes from a post-medieval soakaway (LWC GF62, Period 5.2) which disturbed pottery from the early medieval robber trenches. A revised figure would therefore place 100% of all Stamford ware in Period 2.2 (or 66% by weight) where it would comprise 38% of the assemblage from Period 2.2 (or 6% by weight). In Period 2.2-3, the fabric comprises only 0.8% (by weight) of the assemblage and only 0.3% in Period 2.4.

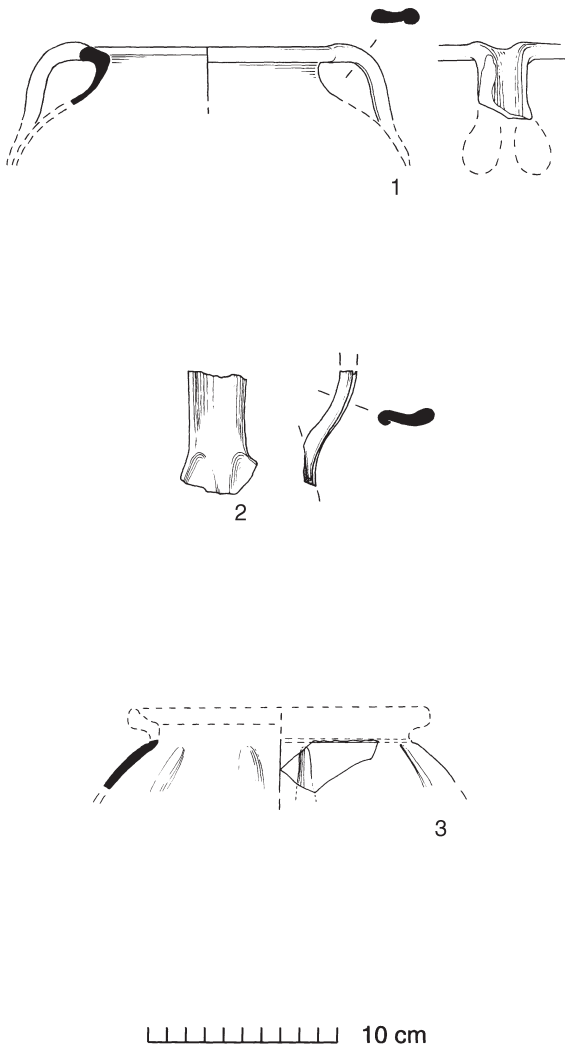

Fig 12 Stamford ware: spouted pitchers (nos 1-2); fluted jar (no 3). 1:4.

**Early medieval shelly wares (Fabric 12)**

This is a fairly wide category which embraces a variety of Saxon and Norman shell- and sand-and-shell-tempered fabrics. It has here been divided into four general types which are each considered in detail.

**Early medieval shelly wares without sand (Fabric 12A)**

[Figs 13.1-2]  
 Weight: 0.785 kg  
 No of sherds: 44  
 EVEs: 0.30

**Fabric**

This distinctive fabric has a smooth paste containing moderate coarsely-crushed shell, including some mussel but mostly unrecognisable fragments (perhaps oyster), which form prominent plates on the surface. There are also small, but significant, inclusions of iron oxide. The vessels are soft, having been fired at a low temperature, and the shell content has not vesiculated. While some examples are grey throughout, most have a medium grey core with light brown surfaces. The vessels are hand-made to a reasonably high standard, perhaps with wheel-finished rims.

**Form**

The form is that of a cooking pot with wide heavily sagging base and short upright slightly everted rim which is slightly thickened, flat-topped or beaded, above a square shoulder (Fig 13.1-2). The form is entirely undecorated.

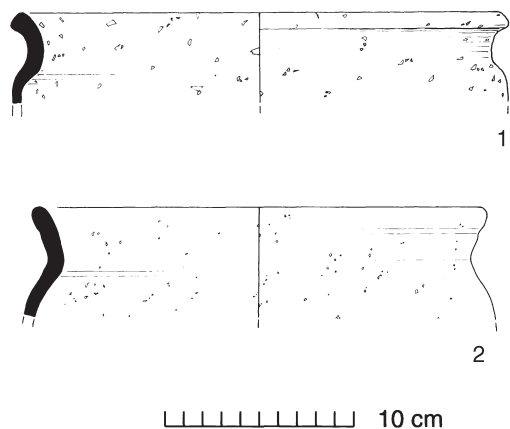

Fig 13 Shelly wares without sand: cooking pots (nos 1-2). 1:4.



## Dating

There is no strong independent site dating evidence for this type. Only one sherd (CPS F46) is phased in a contemporary context of Period 2 (c 1000-1200), but, as it always occurs with other early medieval pottery types, especially Fabric 13, there can be little doubt that Fabric 12A is current within this time. As Fabric 12A is rare here, it is unlikely to have been made in the Colchester area. It occurs with similar shelly wares and Fabric 13 at Asheldham Camp in the Dengie peninsula (Walker 1991a, fig 14.11-13), and elsewhere in central Essex, at Rivenhall. Here, it has been suggested, Fabric 12A appeared in the early 11th century (slightly preceding Fabric 13), and may have disappeared by the mid 12th century (*ibid*, 31; Drury *et al* 1993, 80). The simplicity of the rims illustrated from Colchester is reminiscent of Fabric 13 rims in the lower fills of the town ditch at Lion Walk (Stratified Group 4). A late 11th- or early 12th-century date might therefore be suggested.

Five sherds may be an overfired or burnt version of the main fabric. Again, the fabric contains moderate coarsely-crushed shell; mostly mussel, some gastropod and possibly oyster. Some red iron oxide also occurs. On the vessel surfaces the shell has vesiculated to a large degree giving a corky appearance. The dark grey-brown colour and brittleness are also suggestive of overfiring. All but one sherd came from the same site and no more than two or three vessels can be represented. The only form represented in

this overfired fabric is the cooking pot (Fig 13.2), with a plain slightly everted rim above a more rounded squared shoulder.

All four sherds from Long Wyre Street (COC) occur in contexts accompanied by Thetford-type ware and Fabric 13 (including a curfew, Fig 31.68, and a thumbled rim). The Thetford-type ware may be a little residual, but an early 12th-century date for these contexts seems likely. One sherd of this ware occurred with a cooking pot in a slightly different shelly fabric (Fabric 12B, Fig 14.1).

### Early medieval slightly sandy shelly wares (Fabric 12B)

[Fig 14.1-4]  
Weight: 0.540 kg  
No of sherds: 22  
EVEs: 0.43

The fabric is very similar to that of Fabric 12A, but the matrix is slightly sandy, and the vessels appear to be wheel-finished and are fired to a slightly higher temperature, giving a harder surface texture. Like Fabric 12A, they are normally grey or have light reddish-brown external surfaces.

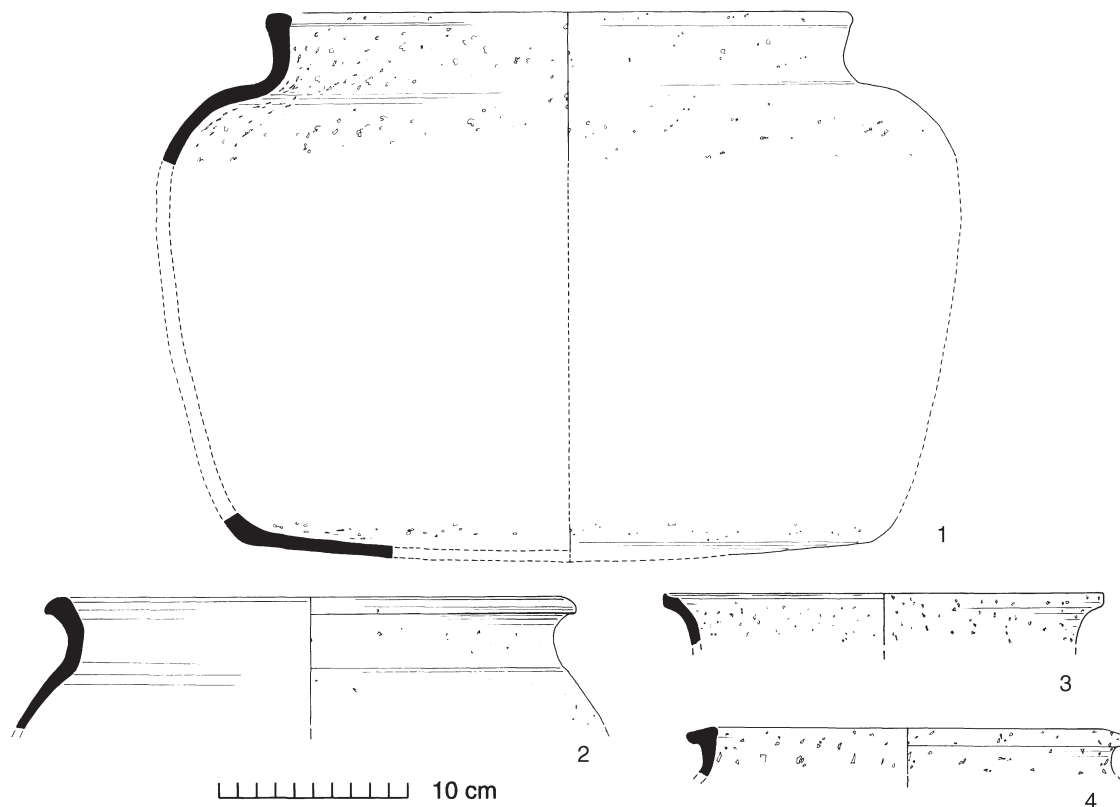

Fig 14 Slightly sandy shelly wares: cooking pots (nos 1-4). 1:4.

The forms include exceptionally large cooking pots with rim diameters up to 330 mm. They may have relatively simple thickened rims and squared shoulders like vessel Figure 14.1 (and Cunningham 1982a, fig 26.6), or an externally thickened rim-like vessel Figure 14.2, which may have been added separately to a hand-made body. Another rim sherd (1.81 GF293) is more irregular, and is either thickening to a handle or is a waster. Smaller vessels also occur: Figure 14.3 has a pointed rim (sooted), while Figure 14.4 (Period 3.1, c 1150/1200-1250/75) has a surprisingly developed rim more typical of 13th-century greywares.

Again, most of these are residual in their contexts. The earliest phased example is a single body sherd from the town ditch at Lion Walk (LWC NF2103, Period 2.4, c 1150-1200), followed by LWC NF2104 (c 1200-1225), and many others of Period 3.1 or later. Figure 14.1, an unphased example, is from an early 12th-century robber trench.

There is no obvious chronological difference between 12A and 12B types, except that 12B seems to continue later in use. As the main distinction is in size and quantity of temper in the fabric, one is tempted to wonder if 12A is the normal fabric for smaller pots, while a sandier matrix 12B is necessary for larger ones. Both these fabrics have some petrological and typological similarity to Early Medieval Shelly Ware at London. The latter is thought to come from north-west Kent and dates from the early to mid 11th century, but is commonest in the late 11th and 12th centuries (Vince & Jenner 1991, 63-8). While example Figure 14.4 does resemble shelly rim forms found in north-west Kent, the others are probably of more local origin (Nigel Macpherson-Grant, pers comm).

#### Early medieval sandy shelly wares (sand predominant) (Fabric 12C)

[Fig 15.1-5]  
Weight: 3.020 kg  
No of sherds: 119  
EVEs: 0.77

The fabric is heavily sandy, very much like Fabric 13, with sparse shell in fairly large pieces distributed more or less evenly through the fabric. Some shell fragments are recognisable as cockle and possibly oyster, but the majority of shell inclusions are calcined and unrecognisable. Red iron oxide is commoner in some examples than others but always present to some degree. The quartz sand element is coarse, with rarer very coarse sub-rounded and opaque grains. The vessels appear to have been made in two halves, the base and lower body which is hand-made and the rim and upper body which is much finer and more regular. Firing is rather uneven, not normally producing very hard surfaces; like Fabric 13 they usually have reddish-brown surfaces with a grey core.

Cooking pots are the only vessel form represented in 'standard' Fabric 12C. They usually have fairly simple thickened or slightly beaded everted rims (Fig 15.1-2) and generally resemble Fabric 13 forms. One rim from the castle is flat-topped (Cunningham 1982a, fig 26.8), while two others have thumbled rims (*ibid*, fig 26.9-10); the latter

example is notable for its neckless form and squared rim resembling late 13th-/14th-century greyware forms. Apart from thumbled rims, decoration occurs on only three examples. The first (not illustrated) has girth grooves like some Fabric 13 vessels from the Middleborough kilns; the second (Fig 15.3) has bands of incised vertical lines, while a third vessel from the castle is decorated with an incised horizontal wavy line (*ibid*, fig 26.7).

Inevitably, a small number of variant fabrics exist within the 12C category and these deserve some mention. Four sherds are distinctive in that, rather than platelets of coarse shell, they are tempered with a finer 'peppering' of sub-rounded calcareous particles normally around 1 mm or less. This variant, which includes the bowl Figure 15.4, is now known to be a London area fabric (see below). One rim (CAR 1, fig 32.19) has a very compact fabric with abundant red iron oxide. A sagging base (CPS F46), lacking in iron oxide, is tempered consistently with rounded grains of orange-red tinted quartz. Four sherds, including a thickened flat-topped rim (1.81 C3, not illustrated), have some of the characteristics of Fabric 20 greyware: hardness, wheel-thrown etc. One unique sherd (Fig 15.5) has a finely rilled outer surface and what may be a wavy, combed band. The fabric is hard with abundant ill-sorted shell and some fine sand set in a dark grey matrix; the surfaces are a very pale brown.

#### Dating and discussion

Both stratigraphic and associated ceramic evidence point to the currency of this fabric in the 11th and in particular the 12th century, continuing to some extent into the 13th century. Shelly wares never comprise much more than 1% (by weight) of any period assemblage they occur in. The earliest incidence of the ware is represented by two sherds from a pit context of c 1000-1050+ associated with a large quantity of Thetford-type ware and a smaller quantity of Fabric 13 (Stratified Group 3). One of the Fabric 12C sherds has a plain everted rim (not illustrated). A second rim sherd (Fig 15.1) came from the lowest fill of the Lion Walk town ditch, dated to c 1050-75 (Stratified Group 4). In addition to Thetford-type ware and Fabric 13, it occurs in other contexts with St Neots-, Stamford- and Andenne-type wares (CPS F46, Period 2, c 1000-1200; CPS F112, Period 2.2-3, c 1100-1150). An almost whole cooking pot (Fig 15.2) came from a pit of c 1125-50 where it was one of at least 30 vessels, mainly in Fabric 13, but including a sherd of Hedingham ware (Stratified Group 5). In several instances, the fabric occurs in Period 3.1 (c 1150/1200-1250/75), but only once in Period 3.2 (c 1250/75-1400). Some degree of survival into the 13th century is therefore possible. Both 'standard' and 'peppered' fabrics appear to be contemporary, while the hard, greyware-like fabric is not present until Period 3.1.

'Standard' Fabric 12C is by far the commonest shelly fabric in Colchester, and it represents an industry that parallels the Fabric 13 sandy-ware industry in many respects. Nevertheless it is vastly overshadowed by Colchester's native Fabric 13 industry, which included a shell-dusted variant, Fabric 13S (see p 40). However, only thirteen miles away to the west and south-west, the situation is totally reversed. Here at sites along the Brain Valley, between Braintree and Witham, shelly wares dominate while Fabric 13 is in a minority. This impression is based upon the examination of

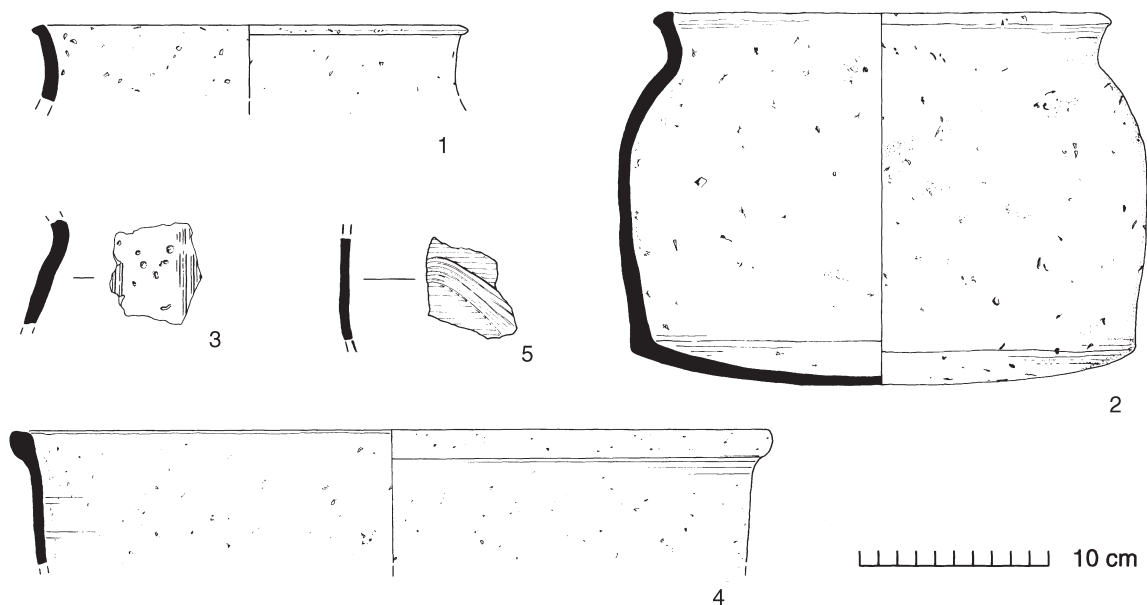

Fig 15 Sandy shelly wares: cooking pots (nos 1-3 & 5); London EMS bowl (no 4). 1:4.

the pottery from Cressing Temple (unpublished), and an examination of the pottery from an early medieval earthwork at Blunt's Hall, Witham, now in the Colchester Museum (Trump 1961). The shelly wares at these sites compare favourably with Fabric 12C and, to some extent, Fabric 12B at Colchester. At Cressing Temple, the shelly wares have thumbled rims and combed and incised decoration in much the same manner as Fabric 13. Thumbled rims and rim forms very similar to Colchester's Fabric 12C occur at Blunt's Hall (*ibid*, fig 2, 'ware A'), and a deeply fire-reddened trench-like feature on this site was interpreted as a clamp kiln. It was choked with charcoal and contained some sherds of the shelly ware 'ware A' (*ibid*, 37). Whether or not this was actually a kiln remains open to question. The earthwork at Blunt's Hall was interpreted as an 'adulterine' castle of the Anarchy Period (1135-1150) of Stephen's reign and, while this too remains open to question, the dating is quite consistent with the style of pottery present. At Cressing Temple, the absence of early medieval imports and the occasional association with Hedingham stamped strip jugs pointed to a rough currency of c 1125-1225/50 for the shelly wares there.

The interesting fact is that, here in the Brain Valley, there appears to have been a thriving shelly ware industry in the 12th and early 13th centuries, only a few miles from Colchester where a completely different situation prevailed. There seems little reason to doubt that most of Colchester's shelly wares also had their origin in the Brain Valley.

Early medieval shelly wares do not appear to predominate in north-east Essex during the 11th to early 13th century as they seem to over much of the county. They are common, as we have seen, in the Brain Valley and at Rivenhall (Drury *et al* 1993) and they predominate at sites further south such as Writtle, near Chelmsford (Rahtz 1969, fig 52.1-10), at Hadleigh Castle on the Thames estuary (Drewett 1975, 112), and at Waltham Abbey in the south-west of the county (Huggins 1988, 136). It is probably

significant from a dating point of view that only a single sherd of shelly ware (Fabric 12B) was recovered from excavations at Harwich, in the extreme north-east of the county, where all the excavated pottery is datable to after c 1175/1200 (Walker 1990a). The low frequency of true shelly wares in the Colchester area may have been due to the competition presented by locally produced shell-dusted ware (Fabric 13S).

Some of the Fabric 12C variants in Colchester may have been produced outside the county. The rare calcareous 'peppered' variant which includes the bowl Figure 15.4 was thin-sectioned and proved to be very similar in fabric and form to bowls in Early Medieval Sandy Ware (EMS) at London (Alan Vince and Jane Young, pers comm). This fabric, which contains algae rather than shell, is believed to have been made in the Thames Valley and dates from the late 10th or early 11th century through to the mid 12th century (Vince & Jenner 1991, 56-9). The orange-red tinted sand grains in the base fragment from the Cups Hotel site could suggest a Surrey origin (CPS F46, Period 2, c 1000-1200). The pale-firing sherd with combed decoration (Fig 15.5) could be a regional or Continental import.

#### Oolitic wares (Fabric 12D)

[Fig 16.1-5]  
Weight: 2.085 kg  
Number of sherds: 77  
EVEs: 0.99

Among the post-Roman shelly wares, this is a distinctive, if minor, category. The fabric is virtually sand-free and

dominated by abundant calcareous ooliths mostly around 1 mm in diameter. These erupt through the surface of the vessel giving a finely speckled effect. It is clear, in several cases, that the nucleus of these ooliths is a microscopic fossil gastropod. Interspersed with the ooliths, other inclusions of fossil shell origin appear sub-square or sub-rectangular and may be of larger size. Quartz grains, when present, are fairly large, sub-rounded and clear, often iron-tinted, but these are generally rare. A little red iron oxide occurs in some examples. The matrix has a pasty brickearth-like character with much very fine mica. Most examples have a dull oxidised outer surface and a reduced inner surface and core; some are completely reduced, and several show variations in tone reflecting poorly-controlled firing conditions. The fabric is, however, compact and hard and cannot be scratched with a fingernail. Another distinguishing characteristic is the external striations caused by random wiping of the surface of the pot which dragged the ooliths and other particles across the wet surface, possibly covered with a clay wash. All the vessels appear to be hand-made, probably coil-built.

Initially it was thought that this was a late Saxon or early medieval fabric, although it was noted that at least one vessel (Fig 16.1) bore a strong resemblance to the shape of some mid-Saxon vessels. Most of the more complete examples were bereft of useful associations, while the majority of sherds generally occurred singly or in pairs in 11th-/12th-century robber trenches and pits. This gave the impression that the fabric was already residual in these contexts. Secure Anglo-Saxon contexts are very rare in Colchester, and only one produced an example of this fabric (see below). It was therefore inferred that this was an early medieval ware of perhaps the 10th-11th centuries, and this seemed confirmed when sherd Figure 16.4 was subsequently identified as probably 11th century (Alan Vince, pers comm, 1987). At a late stage in the preparation of this report, however, information was received which suggested that this was not a single fabric, but at least two, comprising a middle Saxon element and an early medieval element (Terry Pearson, pers comm, 1987).

Technically it should be possible to divide this collection into its earlier and later elements. The middle Saxon ware has a rather sparser distribution of ooliths along with a greater number of limestone inclusions. The Saxon brickearth

character of the fabric is a little more in evidence as are the external striations. The early medieval ware is more heavily charged with ooliths.

Vessel form is undoubtedly the best guide to distinguishing between the two fabrics, but in practice this is rarely possible. Time did not permit a complete re-examination of all the sherds, but a trial sample revealed the difficulty of distinguishing clearly between one fabric and the other, particularly when most of the specimens are featureless body sherds. Pending further investigation, it has not therefore been considered worthwhile to attempt a detailed quantification of the sherds in terms of the two or more industries represented, and indeed it may transpire that these are simply different phases of the same industry. It is possible to say, however, that the 77 sherds were recovered from 19 different sites (although some of these adjoined) and probably represent at least 19 vessels. On the evidence of rim sherds, it is possible to distinguish with certainty a minimum of four vessels in each fabric, and this may be a crude indication that they occurred in roughly equal quantities.

### Mid-Saxon forms

[Fig 16.1-3]

Three cooking pots and one lamp or small bowl have been distinguished. The only complete cooking pot profile (Fig 16.1) has a baggy form with a rounded base and an everted flat-topped rim, a form shared by the other two examples (Fig 16.2). On these vessels the oolith content is noticeably more random in its distribution than in the early medieval fabric. Figure 16.1 varies considerably in thickness and is clearly hand-made. The fabric of this vessel is coarser than usual with a greater presence of fossiliferous limestone (up to 2 mm) including fossil gastropod and rare crinoid. It is heavily sooted (or burnt?) on the inside and on the rim, and this internal sooting is seen on other examples. Rim diameters are fairly small, around 105-170 mm.

Figure 16.3 is sooted inside and is almost certainly a lamp, which thus makes it the earliest post-Roman example of this form from the town.

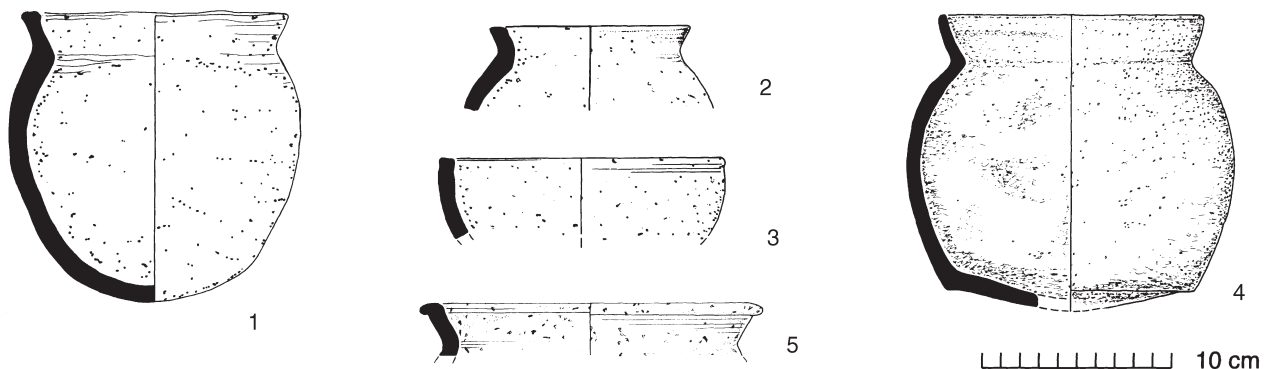

Fig 16 Oolitic wares — mid-Saxon forms: cooking pots (nos 1-2); bowl or lamp (no 3) — early medieval forms: cooking pots (nos 4-5). 1:4.

## Early medieval forms

[Fig 16.4-5]

Only cooking pots are present. The most complete example (Fig 16.4) has a more globular body with a clearly defined sagging base and a slightly flared neck with a plain rim. Two other examples have a very similar rim, except that on one the lip has been slightly flattened. These pots are also hand-made, but with more regularity than the mid-Saxon fabric. Figure 16.4, and particularly the other two rims (not illustrated), bear a series of slight depressions on the lower outside surface which appear to be thumb impressions produced during the attachment of a separately-made rim. Rims are generally of larger diameter than the earlier fabric, with a range of around 140-280 mm.

Oolitic inclusions are much commoner on the upper half of vessel Figure 16.4, and particularly common on the underside of the base where they may have been added as an external gritting. The base is a little sooted, but heavy sooting is confined to the shoulder and to the rim, ending just inside in a straight line (perhaps protected by a lid?).

One other cooking pot (Fig 16.5) has a flattened beaded rim. Its greater regularity suggests it may have been wheel-finished.

## Source and dating

Occasional ooliths, such as are found sporadically in some mid-Saxon pottery at Colchester, may derive from the local recent glacial deposits brought to East Anglia from areas further to the west (Hunter 1979, 232). But the abundant oolitic inclusions seen in the fabrics under discussion here must derive from areas with outcropping oolitic limestone, and there are no such outcrops in Essex. Outcrops of oolitic and other fossiliferous limestone occur in the belt of Jurassic strata that sweeps across southern England from Dorset to Lincolnshire. The closest the oolitic series in this belt get to Colchester is approximately 68 miles away to the north-west near Harrold, between Bedford and Northampton. Coincidentally, this area lies within the core distribution area of that better-known shelly ware, St Neots-type ware (*ibid*, figs 104-5), but there is little similarity between that wheel-thrown industry and these hand-made oolitic wares. It is interesting, however, to compare the mid-Saxon oolitic forms from Colchester with the very similar forms of 9th-century hand-made vessels from Eaton Socon, Bedfordshire. These occur in a fabric resembling St Neots-type ware, but their plain everted, often flat-topped rims, together with external wiping, provide an interesting parallel (Addyman 1965, 53-4, fig 8, 6-11 & 32). Curiously, oolitic ware of the type known from Colchester is unknown from the town of Bedford (G Brine, pers comm, 1987).

Opinions vary as to the precise source of this ware. It has been suggested that the baggy cooking pots and lamps (Fig 16.1-3) could be products of a Mid-Saxon oolitic tradition operating somewhere in Northamptonshire (Terry Pearson, pers comm). Mid-Saxon here is taken to mean c 650-850. The globular sagging-based cooking pots, with their more heavily-charged oolitic fabric (Fig 16.4-5), more closely resemble products of the much later Lyveden-Stannion industry, also in Northamptonshire (Terry Pearson and Alan Vince, pers comm). Lyveden and related oolitic/

calcareous wares are known from excavations at St Peter's Street, Northampton, but none can be dated there before c 1100 (McCarthy 1979, 156-7). However, Colchester's oolitic wares are also very like another fabric occurring at Northampton known as Cotswolds-type oolitic ware which could start c 900 but is mainly current c 1100-1300 (Paul Blinkhorn, pers comm). Whatever their source(s), Figure 16.4 on form alone probably dates to the 11th century (Alan Vince, pers comm), while Figure 16.5 with its more developed rim could be 12th or even 13th century (Terry Pearson, pers comm, 1987).

There is some dating evidence from Colchester but it is of limited value. Most of the baggy pot Figure 16.1 was recovered from a robber trench for a Roman building on Culver Street Site B (1.81 BF810), while other fragments of the same pot appeared to be intruded into apparent Roman contexts (BF108 and BL375). However, it could be argued that because this robber trench produced no other post-Roman pottery, and the rest of the pot came from presumed Roman contexts, then the robber trench may itself be an Anglo-Saxon feature, and thus the close association of the other sherds with Roman contexts represents the earliest post-Roman occupation on this site. It may be no coincidence either that a 7th-century sunken hut was also found on this site (Hut 3, Stratified Group 2).

Figure 16.3 occurred as a residual element in an 11th- or early 12th-century pit containing only early medieval sandy ware (Fabric 13) and Thetford-type ware. A sherd of this fabric also occurred in Stratified Group 3 (c 1000-1050). Figure 16.4 occurred alone in a small pit with no useful associations (and was perhaps votive).

Oolitic wares in Colchester have an entirely intramural distribution. They are common on the extensive Lion Walk and Culver Street sites as well as the Cups Hotel site, and one sherd occurs on the Long Wyre Street site (COC). All these sites produced evidence of Anglo-Saxon occupation. It is interesting to note that the extensive Middleborough site, which lies outside the town wall, did not produce a single sherd of this ware and there is no firm evidence of post-Roman activity on this site until the 12th century.

## Early medieval sandy wares

(Fabrics 13, 13S and 13T)

[Figs 17-32 & 247]  
Weight: 386.495 kg  
No of sherds: 28,335\*  
EVEs: 145.17\*

In terms of sherd numbers, this is the most common post-Roman fabric from excavations in Colchester.

## Fabric

This is typically hard and sandy with weakly oxidised, dull brown or grey-brown surfaces and a grey core. Tonal variation is common, occasionally within the same vessel, and completely oxidised or reduced examples are not infrequent. There is abundant quartz sand of medium-

coarse size, rounded and sub-rounded, clear and opaque. The distribution of orange- (oxidised) or grey-tinted (reduced) quartz grains depends to some degree on the firing colour of the surrounding matrix. Moderate and coarse earthy inclusions of red and black iron oxide are likewise influenced by matrix colour. Fine brown mica is common. Rarer material includes earthy iron-rich or grey clay pellets and/or mudstone, calcareous particles, black organic matter or striated voids and occasional flint inclusions.

Fabric 13S is simply a shell-dusted version of the same fabric. The difference between Fabric 13S and other local shelly fabrics (Fabric 12) lies in the superficial nature of the shell element. Rather than an even distribution throughout the fabric, the shell appears to have been dusted onto the surface of the pot so that the rim, shoulder and the central floor area of the vessel receive the bulk of the shell while less exposed areas remain shell-free. Wiping may have distributed the shell a little further and embedded it more securely in the surface. Where it has dissolved out, the surface is pock-marked with flattened voids.

The shell itself consists of coarse and finely crushed platelets commonly about 1-4 mm across. Shell species cannot be distinguished easily but, as no distinctive cockle fragments have been observed, it is likely that the shell consists predominantly of oyster and mussel. Crushed oyster shell was the main ingredient noted in the medieval lime kilns at Lion Walk (CAR 3, 30), whereas the lime kiln at the Gilbert School site contained predominantly cockle with some oyster and mussel (CAR 6, 288-9). Possibly the Fabric 13S potters obtained their shell from the many lime kilns around the town.

Because of the limited extent of shell-dusting on any one vessel, quantification by rim EVEs provides the only reliable gauge of its frequency compared to the larger undusted element of the industry since the rim is always shell-dusted when this operation takes place. Rim EVEs indicate that shell-dusted ware accounts for 18.5% of the whole Fabric 13 industry. The wider significance of shell-dusted ware and its parallels will be considered in the discussion below.

A gradual chronological development in fabric character is discernible but, in terms of dating value, it is secondary to more diagnostic characteristics such as vessel form, rim form, decoration, etc. Of particular value in this respect is the Lion Walk town ditch sequence of *c* 1050-75-*c* 1300 (Stratified Group 4), which allows the evolution of the fabric to be traced in one stratigraphic section. The following summary is based on this sequence and supported by other dated groups from around the town. In the lowest fill of the ditch (*c* 1050-75), 90% of Fabric 13 sherds have brightly oxidised surfaces and reduced grey cores (CAR 1, 39), the fabric is soft and underfired with powdery surfaces and the quartz sand inclusions are well-sorted and medium-sized (generally under 0.5 mm). From early in the 12th century, the fabric becomes harder, denser, more coarsely sandy (grain size 0.5-1.00 mm+), and sometimes reduced. Fabric 13S has also appeared by this time (*c* 1075-1150 in ditch and *c* 1100-25 in LWC G robber-trench complex).

As the 12th century progressed, there appears to have been an attempt to produce thinner-walled, hard grey vessels. Eventually it becomes difficult to distinguish between Fabric 13 and its greyware successor, Fabric 20; this transitional fabric has been called Fabric 13T and comprises 11.2% (by EVEs) of the whole Fabric 13 assemblage. Fabric 13T may, however, also include some accidentally overfired/reduced

Fabric 13 from earlier stages. The transition to Fabric 20 occurred later on in the 12th century and, as shell-dusting is virtually unknown on the transitional fabric, it seems likely that the practice died out at this stage. Just as the grey, reduced fabric developed into Fabric 20, there appears to have been a parallel, if slightly later, development of well-fired oxidised fabric into the sandy orange medieval Fabric 21. The 11th-/early 12th-century vessels often exhibit differences in colour tone within the same vessel, and this is sometimes gradual and sometimes patchy. This suggests a lack of control over the firing conditions such as would prevail in a primitive clamp kiln. By the second half of the 12th century, the regularity and lack of tonal variation suggest the use of more efficient kilns. Several of these kilns have been discovered and excavated (see below, p 57).

At present no petrological studies have been undertaken to determine whether Colchester's Fabric 13 can be distinguished from similar fabrics all over Essex. Superficially they all look very similar.

## Dating

[Figs 17 and 147]

Fabric 13 belongs to that broad pottery tradition known as 'early medieval wares', which depart from late Saxon wares in both quality and form. The principal differences lie in the poorer quality of early medieval wares and in the appearance of the generally larger, broader, sagging-based cooking pot that remained the basic shape of cooking pots throughout the middle ages. This transition occurred in rough terms about AD 1000 (Hurst 1976, 342-3). Similar pottery is found over much of England at this time and those industries most relevant to Colchester are discussed below (pp 69-71). At Ipswich, eighteen miles north-east of Colchester, local sand and shelly wares of poorer quality were already present by the early 11th century, co-existing alongside the wheel-thrown Thetford-type ware industry (Keith Wade, pers comm, 1987). At Maldon, fourteen miles south of Colchester, a local variant of Fabric 13 also occurs in 10th-century levels in the form of small, simple hand-made vessels (Carol Cunningham, pers comm). The Maldon vessels provide the closest parallels in fabric and form to the earliest Colchester Fabric 13, but there is no evidence that the Colchester fabric was current before the 11th century.

There is no doubt that Fabric 13 was for some time contemporary with late Saxon Thetford-type wares, which were the dominant ceramic type in 10th- and early 11th-century Colchester. With rare exceptions, Thetford-type ware is always accompanied in its contexts by Fabric 13 or later wares, although residuality partly accounts for this. Thetford-type ware is believed to have gone out of use in the town early in the 12th century, but the process by which it was displaced by Fabric 13, which then became the dominant ceramic type, had begun well before this date.

The earliest occurrence of Fabric 13 is in a pit off the High Street (Stratified Group 3) dated to *c* 1000-50 on the basis of a significantly larger percentage of Thetford-type ware (74% by weight; 81% by sherds). Only one rim sherd in Fabric 13 was found and this comes from a cooking pot with a flattened or internally-bevelled rim (Fig 20.1). This small group of Fabric 13 (seven sherds) is rather harder

and duller than the earliest sherds from more reliable sequences (see below), although at least one of the High Street sherds was intensely burnt.

Apart from one sherd of Fabric 12C, the lowest layer in the Lion Walk ditch contained only Fabric 13 (Stratified Group 4: LWC NF2101, see p 311). The absence of Thetford-type ware has been taken to imply that this ware had been ousted from the market by this time (CAR 1, 40), or at least that its presence locally was in serious decline. More convincing is the similarity between the Fabric 13 at the bottom of the ditch and that found (with Thetford-type ware) in the 'old turf line' under the bank of Colchester Castle (*ibid*, fig 34.80-82) which is dated c 1050-75 on the basis of documentary evidence (*ibid*, 26, 30, 32 & table 1). On the strength of these similarities the lowest fill of the Lion Walk ditch is likewise dated to c 1050-75 and could even be slightly earlier as the rim and vessel forms are typologically simpler than those (admittedly few) sherds from the castle bank. Further examples of the ware were recovered from the castle rampart over the old turf line (*ibid*, fig 34.88-9 & 92-5), and four sherds are said to have been found in the foundation trench of the castle keep (Dunning 1962, 62), both of which features are datable to c 1075.

Fabric 13 was the only pottery found in contexts associated with the destruction, in 1095, of a small Saxon church demolished to make way for St John's Abbey (CAR 9, 218). On the Gilbert School site, most of a large cooking pot (Fig 22.13) was found in close association with an early medieval bronze furnace and casting pit, possibly for the manufacture of bronze vessels or small bells. A daub

sample from this furnace produced an archaeomagnetic date of 1050-1100 (CAR 6, 137-8). The fabric of the pot is perfectly consistent with the soft, early fabric from the lowest fill of the Lion Walk ditch. Figure 20.5 is from a grave at St John's Abbey post-dating the fire of 1133 but predating the construction of St Giles' Church c 1150 (see p 10). The fabric of this pot is sandier than 11th-century specimens; the upright neck suggests a date of c 1150+.

The percentage which Fabric 13 forms of dated assemblages is shown in Figure 17. The transition from Fabric 13 to the medieval sandy greyware (Fabric 20) and the sandy oxidised ware (Fabric 21) has already been mentioned. This was undoubtedly a gradual event beginning with the appearance of these wares in Period 2.4 (c 1150-1200) and ending with their domination of ceramic assemblages in Period 3.2 (c 1250/75-1400). By c 1225 the production of early medieval sandy ware had probably ceased.

### Vessel forms

[Figs 18-19]

#### Cooking pots/jars (Figs 20-24)

Predictably, cooking pots and similar jar-shaped vessels are the commonest Fabric 13 forms, accounting for 90% of all recognisable forms (Fig 18). No significant difference could be detected between cooking pot forms in Fabric 13 and Fabrics 13S and 13T, although there is some difference in the frequency of rim types and rim decoration (see below).

Cooking pots fall into two basic shapes. The most common shape by far is a fairly squat form, wider than it is high, with a sagging base and a somewhat squared appearance due to the presence of a shoulder. Rims tend to be gently everted (eg Fig 20.3-8). Shouldered forms such as this comprise around 70% of all vessel forms (or around 77% of all cooking pots). The second form is as the first but is shoulderless and globular (eg Fig 22.17 & Fig 23.18-21). This comprises around 20% of all vessel forms (or around 23% of all cooking pots). The distinction between shouldered and globular cooking pots is not always a clear one and sometimes, even with a full profile, a distinction cannot be made.

Chronologically both cooking pot forms appear to be current from the start of the industry until its demise, and little typological development can be discerned. However, the impression gained from the stratified groups and the Middleborough kilns is that globular forms were more common in the early and late stages of the industry, but shouldered forms were dominant for most of the 12th century. Upright necks and a variety of more developed rims become more common after c 1150 (see rims below pp 47-9).

A number of sub-types or variants exist within the cooking-pot category, none of which was ever common. Shallow cooking pots or perhaps cooking 'bowls' (Fig 22.11-12 and Stratified Group 5, Fig 214.3-4) are a minor but recurrent form that may have appeared in the 11th century (and is current c 1125-50 in Stratified Group 5), and may have been produced in the late 12th-century Middleborough kilns. As they were also produced in Heddingham coarseware at the Hole Farm kilns near Sible Heddingham, they almost certainly remained in production c 1175-1200. Small

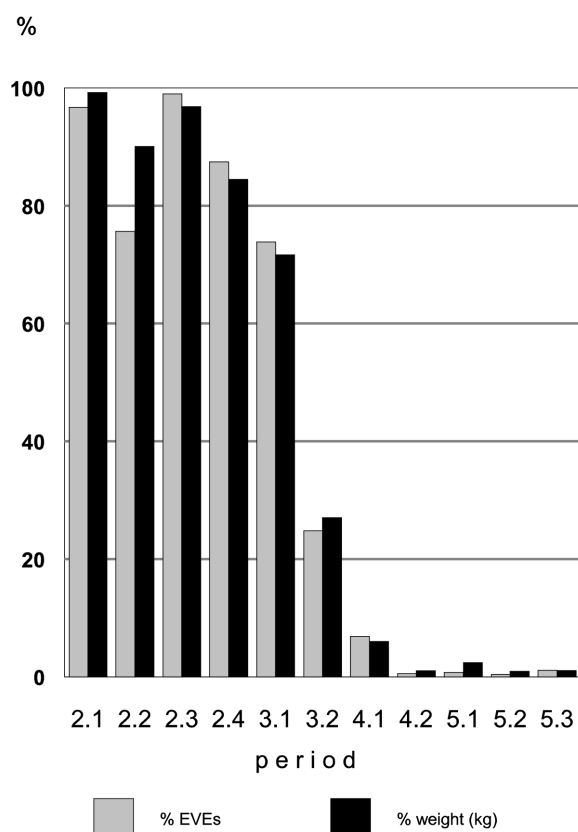

Fig 17 Early medieval sandy ware: bar chart showing percentages in stratified contexts (ceramic periods).

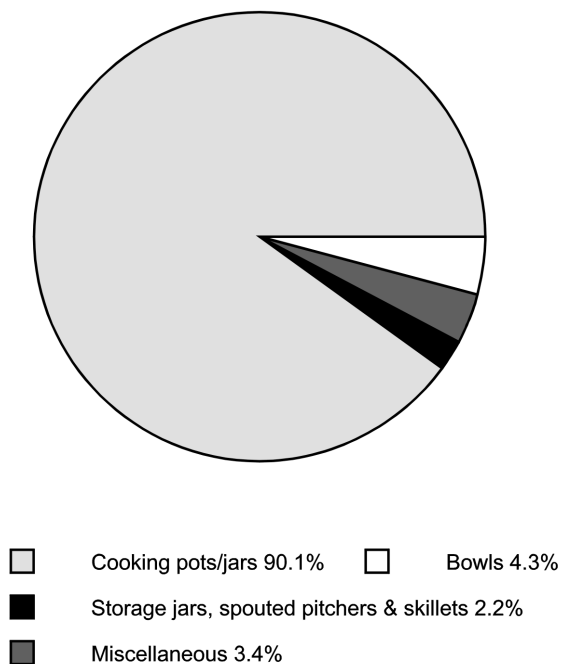

Fig 18 Early medieval sandy ware: pie chart showing vessel assemblage by EVEs.

or miniature cooking pots (Fig 23.22-23, 28 and kilns Fig 33.1-2) were also produced throughout the lifetime of the industry. Other unusual cooking-pot forms such as Figure 22.9 (a 'waster') with its flaring lower walls and the archaeomagnetically-dated deep 'bowl' form Figure 22.13 (c 1050-1100) may be specialised forms (the latter was associated with a bronze-working oven), or else the products of idiosyncratic potters.

All Fabric 13 cooking pots have hand-made bodies often characterised by undulations and internal diagonal smoothing marks (eg Fig 20.8). The regularity of the rims, however, suggests these were turned on a wheel or turntable and subsequently joined to the body. A series of indentations, sometimes visible internally at neck/shoulder level, is the result of this luting process (eg Fig 20.4, Fig 21 and Stratified Group 5, Fig 214.3, which is wholly hand-made). Rims commonly break off at this line of weakness. Rarer tall vessels (storage jars, eg Fig 25.43) may show a seam of small regular indentations internally, which suggests that they were made in sections. It is apparent that virtually all cooking pots continued to have hand-made bodies and wheel-turned rims for as long as the ware remained in production. Within this tradition, it was still possible to produce a reasonably competent product. At a late stage, it is evident that the whole vessel was finished on the wheel or turntable, even though the body was hand-made. The results are often difficult to distinguish from wheel-thrown vessels, as is the case with the majority of pots from the kilns at Middleborough which display regular girth grooves. Bases are commonly knife-trimmed externally. Most basal sherds are sooted underside from their use as cooking vessels over an open fire.



Fig 19 Early medieval sandy ware — miscellaneous late 11th- and 12th-century forms, mostly cooking pots except: pierced-lug bowl (top centre); storage-jar rim (top right); handled skillet (bottom right); fragment of tubular-handled bowl (front right); shell-dusted pots (front centre and back left; height of largest pot 220 mm, from the castle bank excavations, CM 53.52).



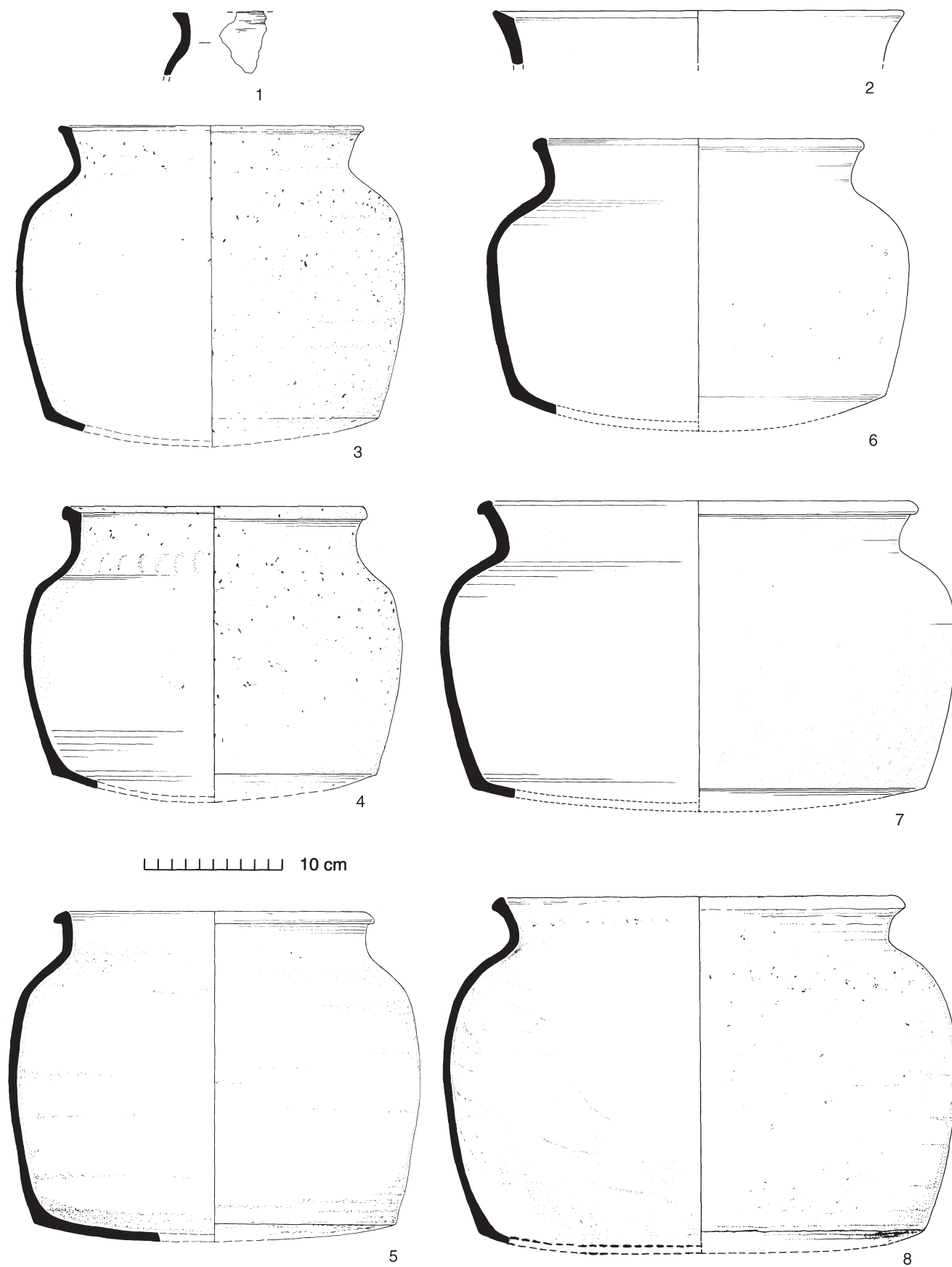

Fig 20 Early medieval sandy ware: cooking pots (nos 1-8). 1:4.

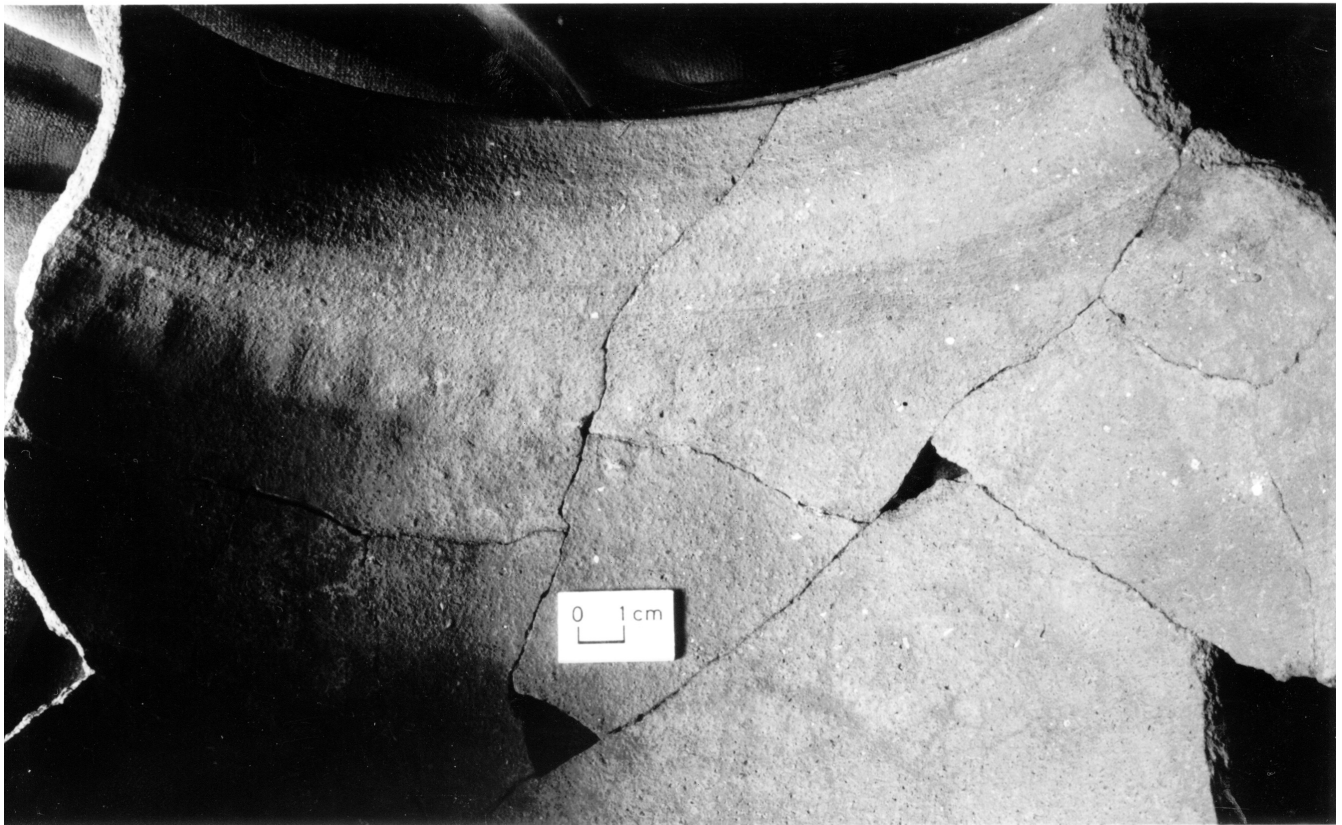

Fig 21 Early medieval sandy ware: internal detail of a shell-dusted cooking pot (no 4) showing evidence of composite manufacture.

#### Storage jars (Fig 25.37-44)

Large robust jars, frequently with lid-seated rims and strengthened by bands of applied thumbed strips, were probably used for storage rather than cooking. Smaller jars in this category, but with plainer rims and no applied strips, would be difficult to tell apart from cooking pot rims were it not for the recovery of one unique vessel of significantly greater height than width (Fig 25.42; Stratified Group 5, c 1125-50). Combed and stabbed decoration are common. Thumbed strips were applied to the body vertically, diagonally and sometimes as intersecting diagonals, all joining a horizontal strip below the rim. An exceptionally large vessel of this type was found in the kilns at Hedingham and is now displayed in Colchester Museum (unaccessioned). This vessel must have a capacity of ten or more gallons, and has a vertical and intersecting diagonal arrangement of thumbed strips in 'IXIXI' fashion. The earliest storage-jar sherd is from a context of c 1075-1150 (Fig 210.24, Stratified Group 4), and a decorated lid-seated rim occurs in a context of c 1100-25 (LWC GF233, not illustrated). Several late examples are known from the Middleborough kilns (see below). The whole lower part of one jar (Fig 25.43, Period 3.1) came from the stokehole of a lime kiln of late 12th- or early 13th-century date and could therefore have been a container for some ingredient used in lime production, although it shows no traces of use.

#### Straight-sided jars (Fig 26.45-47)

A small number of medium-sized jars are without necks and have almost vertical sides. The rim is developed with a horizontal flange which commonly bears combed decoration. The exterior may also be decorated. Figure 26.47 is particularly highly decorated with combing and applied strips with stabbing, all characteristic of material from the Middleborough kilns. Figure 26.46 is from a context of c 1175-1200.

#### Spouted pitchers (Fig 26.48-50)

Spouted pitchers (Form C22) represent a modification of the basic jar form to enable the pouring of liquids, such as wine, ale, etc. They are not very common; only 22 short tubular spouts are known, but a further fourteen vessels with handles are also probably from this form. As in the case of skillets, it is impossible to distinguish fragments of spouted pitchers from those of ordinary cooking pots if the spout and handle are not also recovered. The earliest dated example (Fig 215.17; Stratified Group 5) is from a context of c 1125-50 and is already covered with combed decoration. A later spouted pitcher from the Middleborough kilns (Fig 26.49) is profusely decorated with combing and comb-stabbing. Strap handles are normal; those from the kilns often have raised thumbed edges (kilns, Fig 36.84-85). All the spouts are plain with the exception of another kiln example, which has a collar formed from an applied thumbed strip (Fig 36.89).

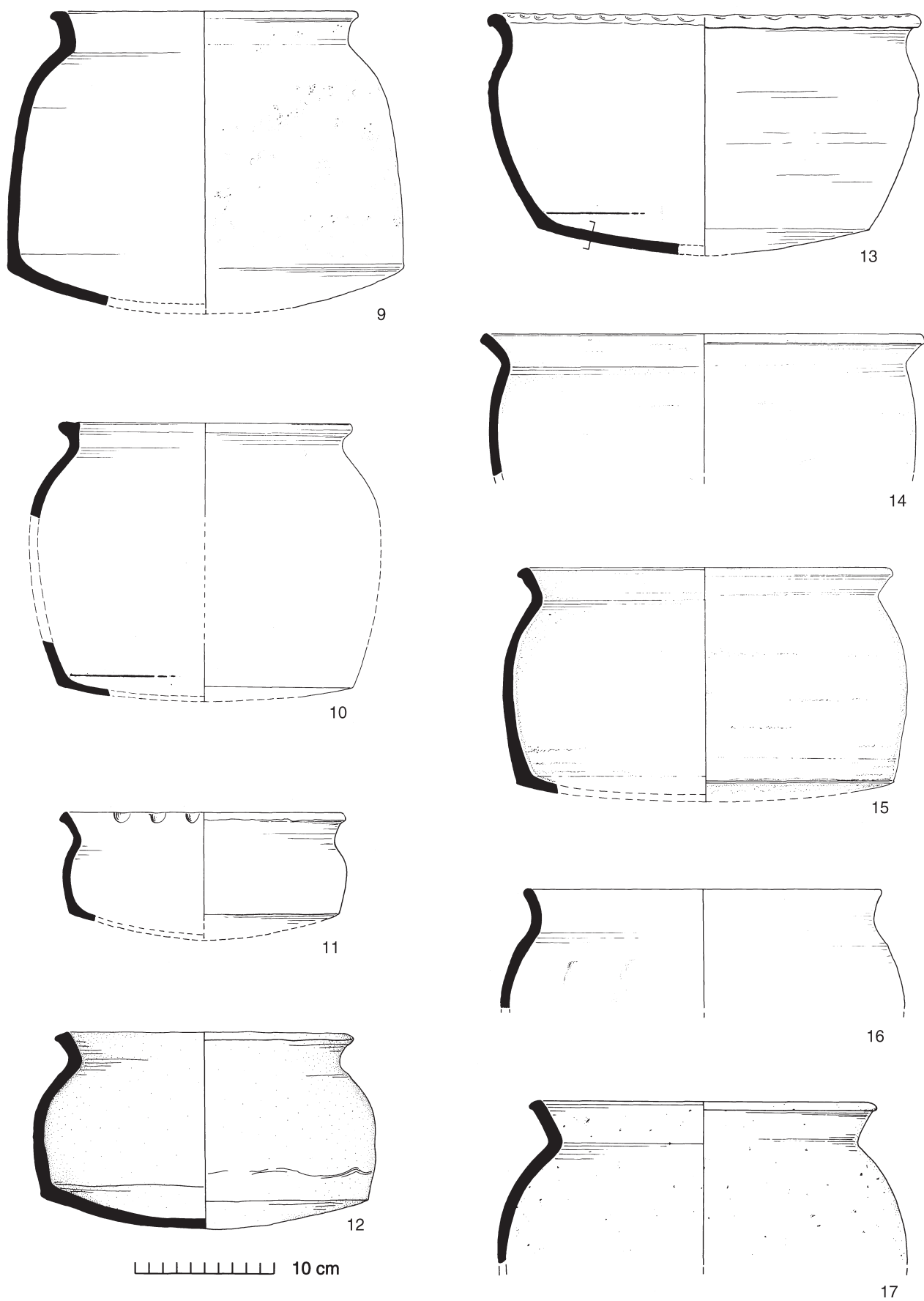

Fig 22 Early medieval sandy ware: cooking pots (nos 9-17). 1:4.

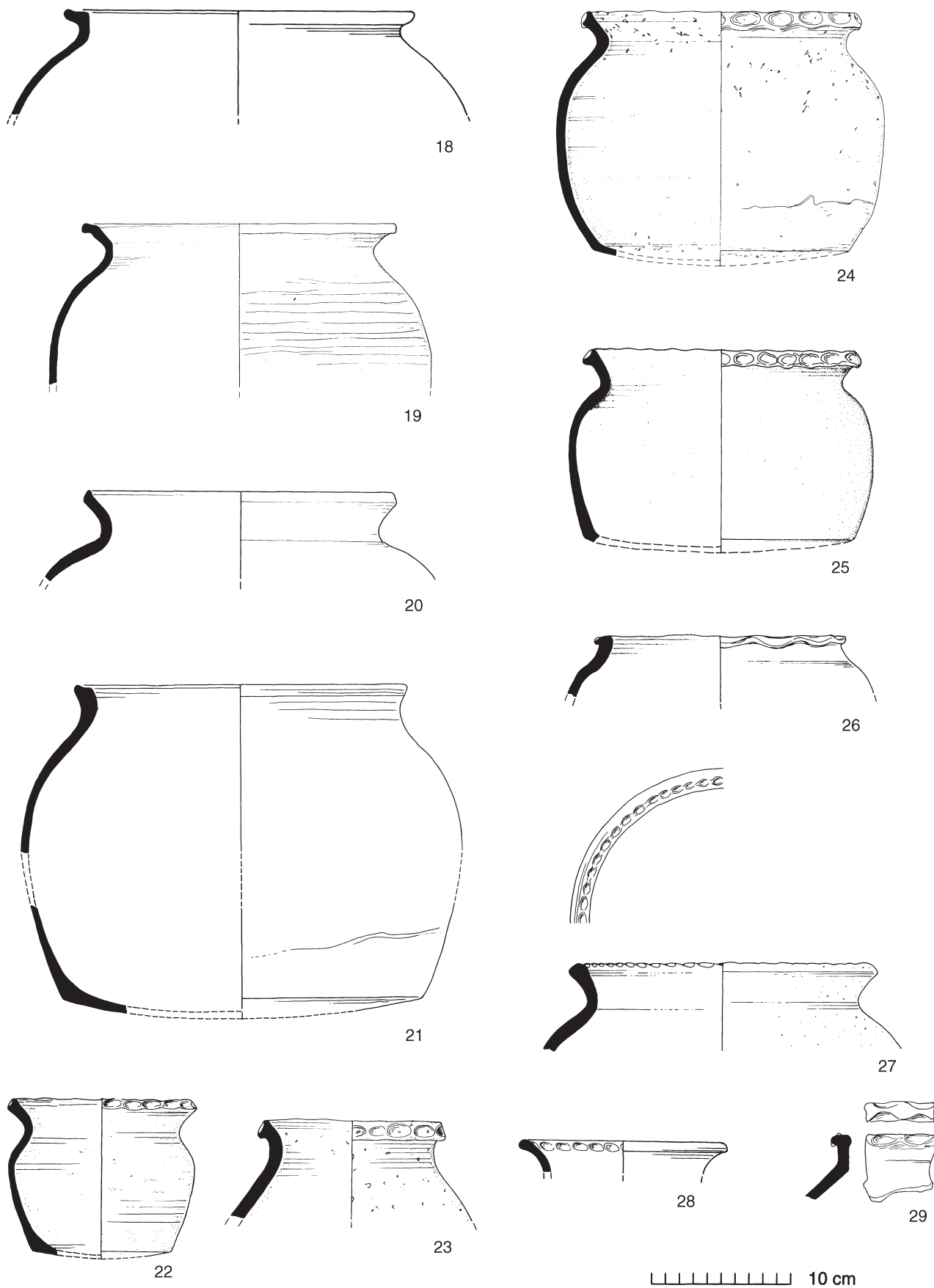
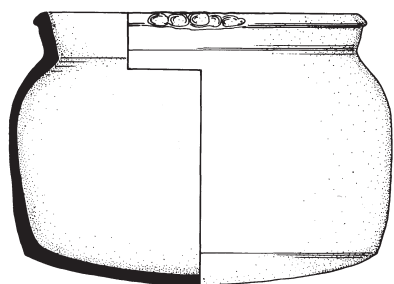
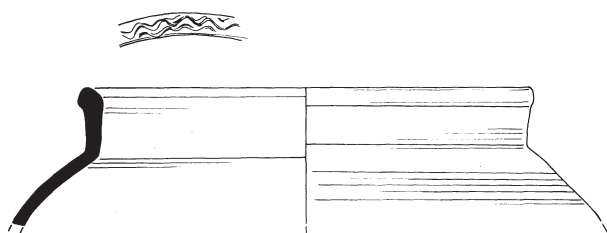

Fig 23 Early medieval sandy ware: cooking pots (nos 18-29). 1:4.



30



31

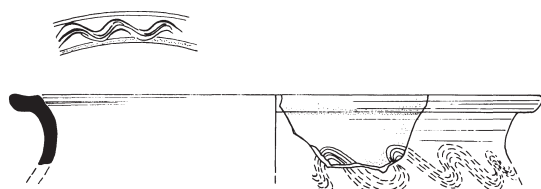

32

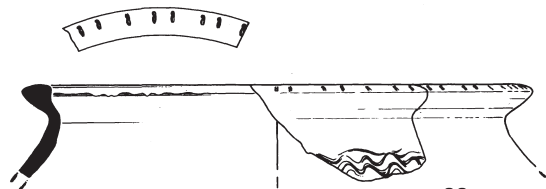

33

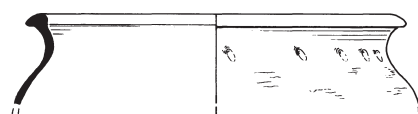

34

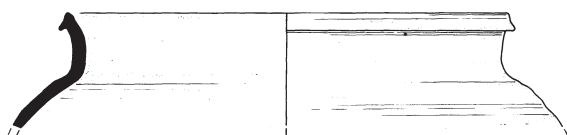

35



36

10 cm

### Handled skillets (Fig 26.51-53)

Handled skillets are rare, with no more than three or four examples identified. Basically, skillets are shallow cooking pots with a pouring-lip and a horizontal handle. Without these distinguishing features, there is little way of telling skillets apart from cooking pots. The earliest probable skillet (Fig 26.53) is from a context of c 1150-1200. The developed rim of Figure 26.51 and its associated pottery suggest it is fairly late in the Fabric 13 date range. Figure 26.52 (Period 3.1) is sooted externally and comes from the ?potter's workshop on the Middleborough site (Building 74).

### Rims (Fig 27)

Simple externally-beaded rims (C1) are the commonest single type of rim found on cooking pots (19.3% by EVEs), followed by thickened, flat-topped, slightly everted rims (B2: 15.3%) and its variant with an internal bead (B2A: 8.8%). Simple, thickened everted rims (B1B: 11.6%) occur with virtually the same frequency as plain everted rims (A1A: 11.3%). Other common plain variants are: plain flat-topped (A2: 3%); rims externally bevelled to produce an incipient bead (A4B: 2.9%); and plain externally bevelled rims (A4A: 2.7%). The remaining 25% comprises several minor rim types (mostly variants of the above and more developed rims), individually accounting for much less than 1% of all cooking pot rims. Lid-seated rims (F1) are made by adding a tongue of clay to a thickened rim to make an internal shelf.

Taking a broad overview, rim types on cooking pots can be reduced to five main groups as follows:

1. Thickened flat-topped types (B2 & B2A) approx 25%
2. Beaded types (C1) approx 20%
3. Plain types (A1A, A2, A4A, A4B) approx 20%
4. Plain thickened types (B1B) approx 10%
5. Other types approx 25%

Separating out Fabric 13S from this overview, the preference here is clearly for the simplest rim types: thickened beaded (B1B), beaded (C1) and plain (A1A), in that order; all other types being insignificant, even the thickened flat-topped rims so common in ordinary Fabric 13. This preference for simple, normally-everted rims in Fabric 13S is understandable when one considers that rims in this fabric are more likely to have thumb-decorated, and this is a technique virtually confined to simple rims. Fabric 13T shows a clear preference for thickened flat-topped rims (B2), and the squared rim (H1) so common on its successor Fabric 20, showing clearly the late and transitional nature of Fabric 13T.

Only the broadest chronological trends can be discerned in the development of rims throughout the 200 years or so of their production. There are some specific rim types which may have a relatively short life span but these are rare. Rim developments, based on the dated contexts from Colchester and on the evidence of dated parallels elsewhere, are summarised in Figure 27. The evidence for dated parallels is considered in more detail in the discussion on pages 68-71 below.

Nearly all the commonest rim types (C1, B2, B1B, A1A, A2, A4B) are present from the 11th century until the end of the industry, though in varying proportions. The most

Fig 24 Early medieval sandy ware: cooking pots (nos 30-36). 1:4.

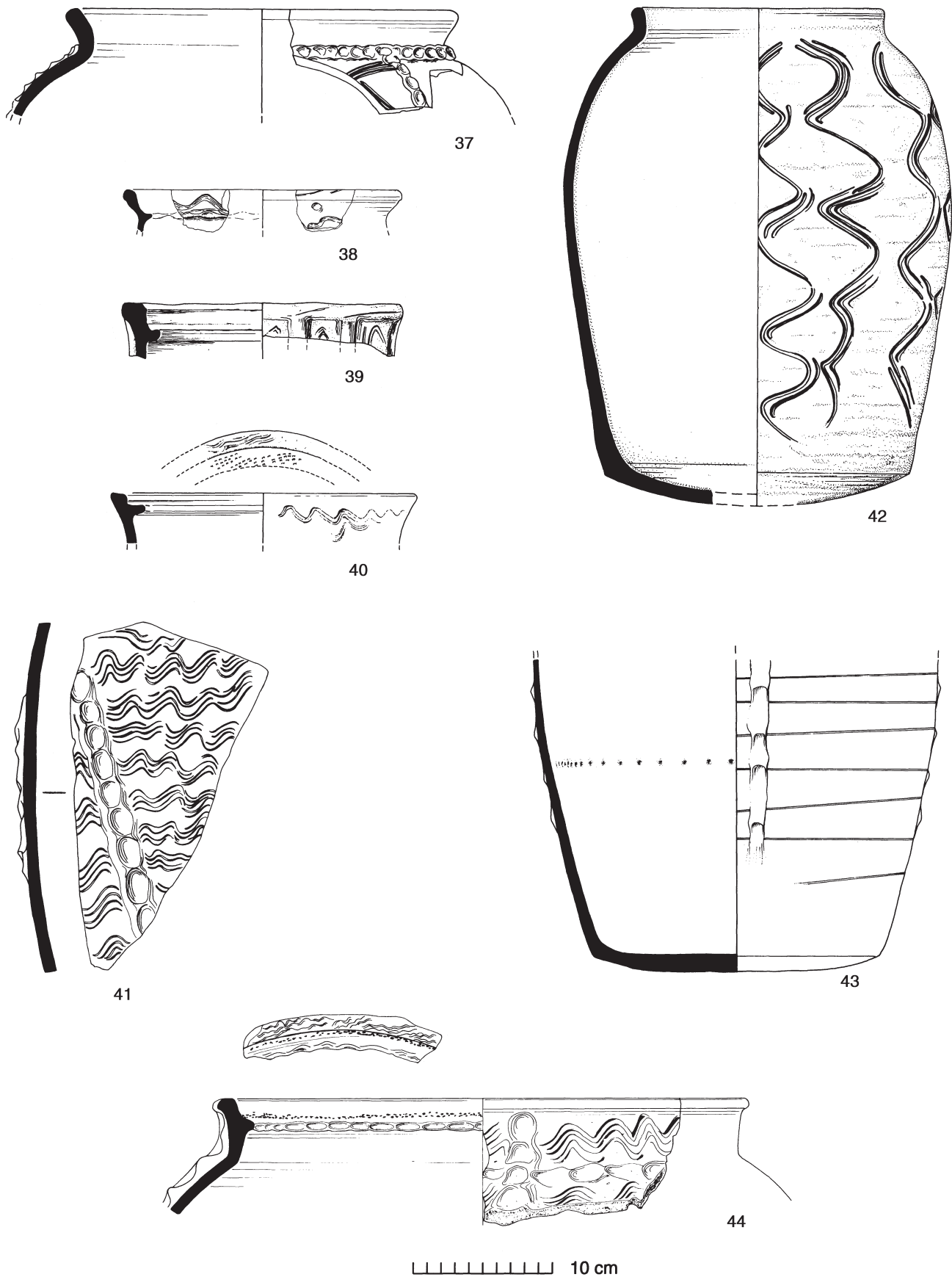

Fig 25 Early medieval sandy ware: storage jars (nos 37-44). 1:4.

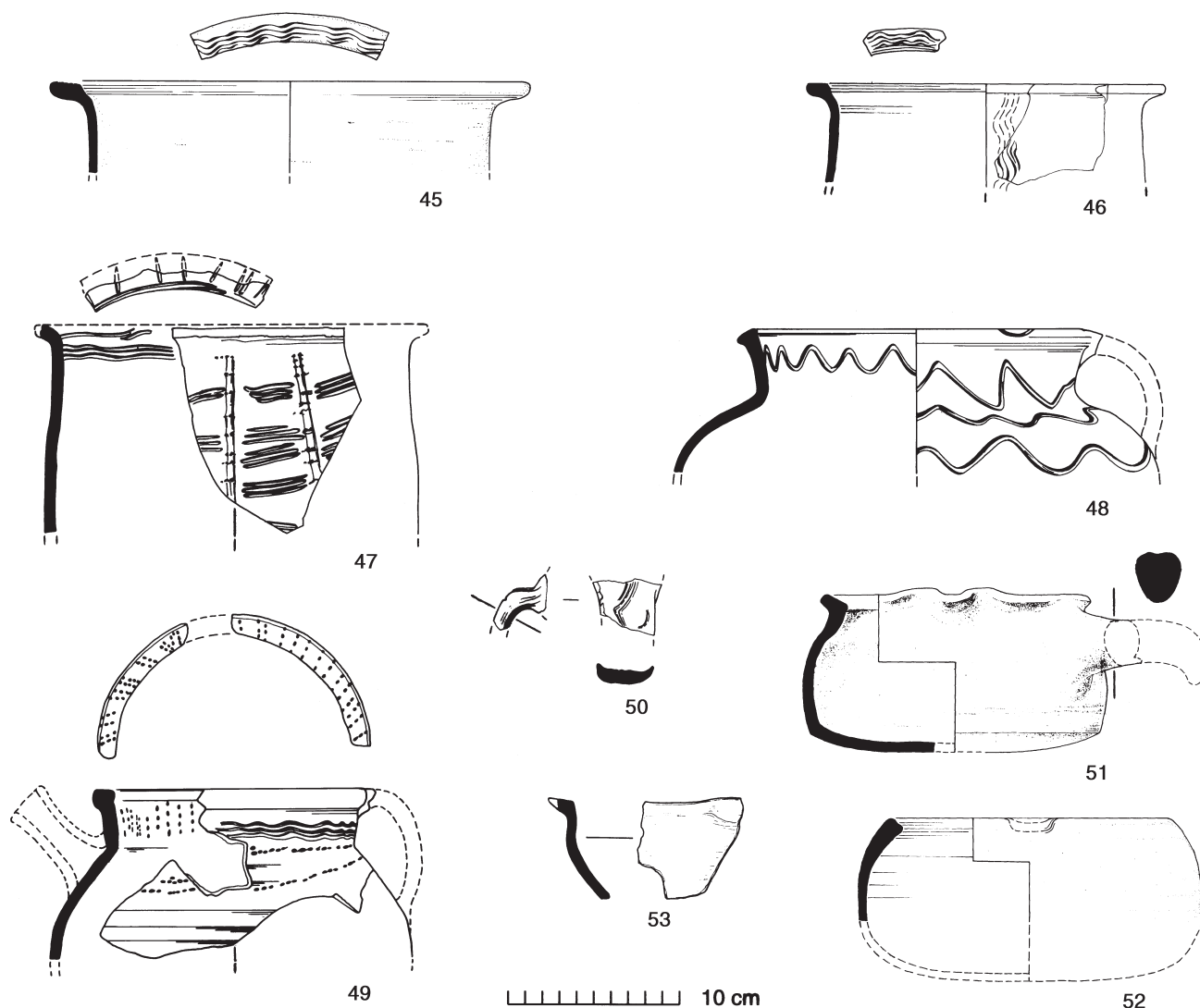

Fig 26 Early medieval sandy ware: straight-sided jars (nos 45-47); spouted pitchers (nos 48-50); handled skillets (nos 51-53). 1:4.

unambiguous trends appear to be the early dominance of plain rim types (A-), followed by their gradual decline. Plain types constitute around two thirds of all rims in circulation in the 11th and early 12th century, but only around one third by the end of the 12th century. Beaded rims (C1) and plain thickened rims (B1B) always seem to have been common but declined a little in the second half of the 12th century, as thickened flat-topped (B2 and B2A) and a variety of more developed rims became commoner.

#### *Cooking-pot and jar diameters (Fig 28)*

Cooking pots and related jar forms have a rim diameter range within 100-380 mm with an emphasis clearly centred around 220 mm. This centring around 210-220 mm is a phenomenon that occurs again in the successor Fabric 20 (Fig 56), and has been observed in other Essex coarseware industries, eg at Gosfield near Hedingham (Petchey 1976, 177-8) and at Mill Green (Meddens & Redknapp 1992,

fig 6.1). Some sort of size standardisation was apparently in use. Rare instances occur of vessels as small as 60 mm (kiln, Fig 34.24), and one or two greater than 380 mm, although these could be bowls.

#### *Decoration: cooking pots and related forms (Figs 29 & 40)*

Twenty per cent (by weight) of the whole Fabric 13 assemblage has some sort of decoration (or 26% by EVEs). Being much fewer in number, forms other than cooking pots or jars are less conducive to the sort of analysis given here and have been omitted.

Twenty-six per cent (by EVEs) of all cooking pot/jar forms are decorated (excluding applied strips). Fabric 13S tends to be the most decorated (30% of Fabric 13S compared with 27% of ordinary Fabric 13), whereas only 9% of Fabric 13T is decorated, illustrating the decline of decoration in the transition to medieval greywares (Fabric 20). The commonest type of decoration is the thumbled rim. Thumbling

RIM TYPE	DATE RANGE							%*	
<b>A1a</b> Plain everted								C	
<b>A2</b> Plain flat-topped								R	
<b>A3</b> Plain internal bevel								R	
<b>A4</b> A. Plain external bevel B. Plain incipient bead								M	
<b>B1b</b> Plain thickened everted								C	
<b>B2</b> Thickened flat-topped								VC	
<b>B2a</b> Thickened flat-topped internal bead								C	
<b>B2c</b> Thickened incipient flange								R	
<b>C1/B1b</b>								R	
<b>C1</b> Beaded								VC	
<b>C3</b> Larger club bead								R	
<b>F1</b> Lid-seated								R	
<b>H1</b> Flanged and upright neck								R	
	1025	1050	1075	1100	1125	1150	1175	1200	1225

Fig 27 Early medieval sandy ware: diagram to show the main types of cooking-pot rim and their estimated date range.  
KEY: % = frequency: R = rare; M = moderate; C = common; VC = very common.

may also occur along the raised edges of handles and, of course, on applied thumbed strips. Fabric 13S is more likely to have thumbed rims than plain Fabric 13 (28% compared with 18%, respectively), but is less likely to have body decoration. Only 3% of Fabric 13T has thumbed rims. Normally thumbing occurs only on the everted lip of beaded and simple thickened rims (eg Fig 23.22-26), although

instances do occur of this on the inner face (eg Fig 23.27-29). The lid-seated rims of large storage jars are usually thumbed along the projecting inner shelf (eg Fig 25.44). The earliest occurrence of thumbing is inside the rim of a cooking pot with an associated archaeo-magnetic date of 1050-1100 (Fig 22.13). Thumbed rims are also present in a context of c 1075-1150 (Stratified Group 4,



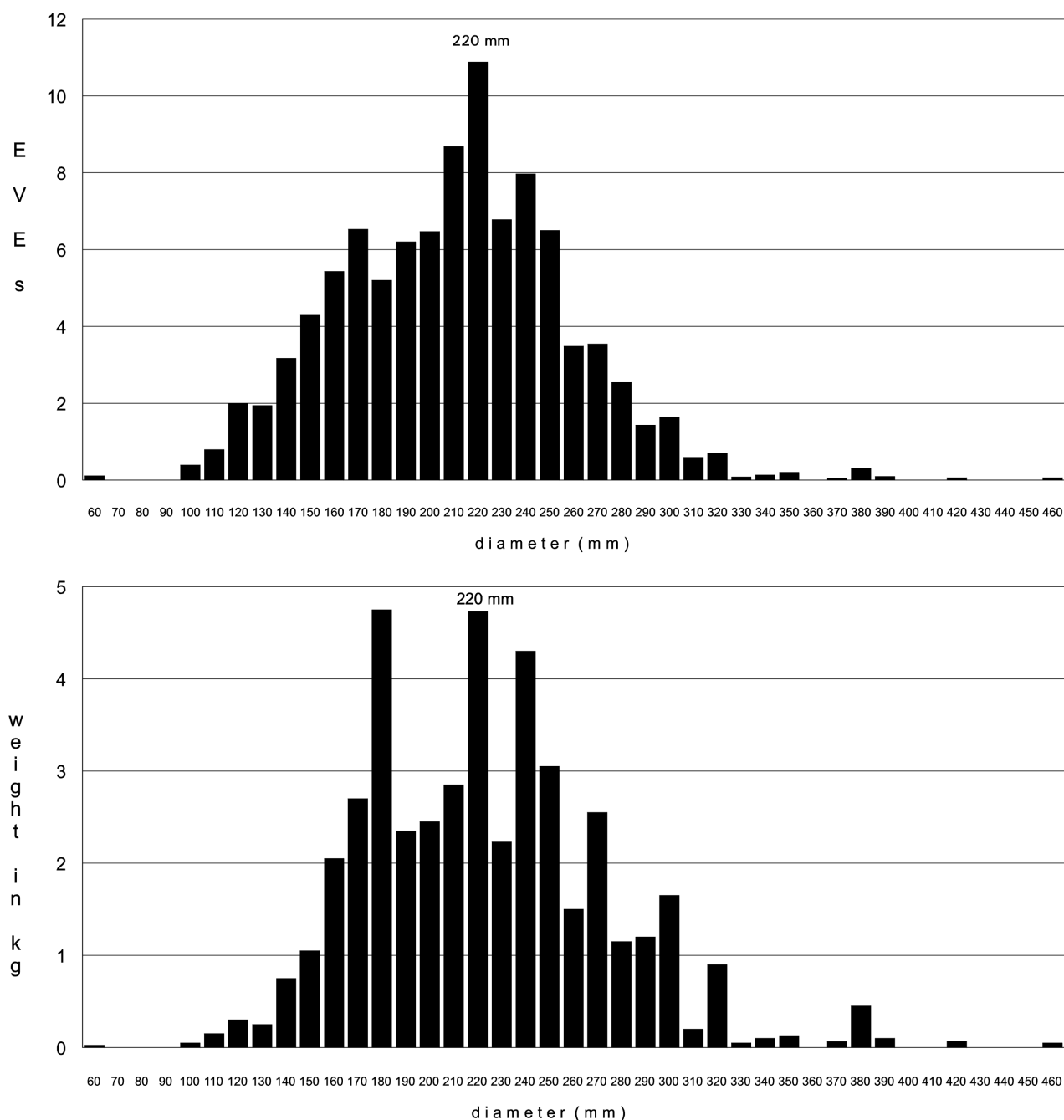

Fig 28a-b Early medieval sandy ware: bar charts showing diameters of cooking pot and jar rims by EVEs and weight (excluding Middleborough kilns).

Fig 210.21) and are plentiful in contexts of *c* 1100-25. On late rim types — such as the flat-topped sub-squared rim (B2) of the Middleborough kilns — thumbing, when it occurs, tends to be superficial and is more likely to occur on the top or the inside edge of the rim rather than the outside (kilns, Fig 34.23 & Fig 35.38, 56 & 76).

Combing (Fig 29) is the second most common form of decoration and perhaps the earliest, being present in the 11th-century contexts from the Lion Walk ditch (Stratified Group 4, Fig 209.14) and the castle bank (CAR 1, fig 34.82), both *c* 1050-75. It is much commoner on ordinary Fabric 13 jars (3.2% being combed, compared with 0.8% on Fabric 13T and 0.5% on Fabric 13S). Undulating bands are

created using a three- or four-pronged tool. Horizontal wavy bands externally below the rim and on the shoulder are particularly common. They also occur on the top of the rim and sometimes even inside it (eg Fig 24.31-33, and kilns Fig 34.25-29). Combing is less frequent on ordinary cooking pots than it is on more unusual forms such as spouted pitchers (eg Fig 26.49), and it is extremely common on large storage jars (eg Fig 25.37-44). On such forms, it frequently covers the whole body.

By Period 3.1 (ie after *c* 1150), several other decorative styles had appeared occurring either singly or in combination. None is particularly common and all are much rarer than pierced or comb-stabbed decoration (1.8% of all

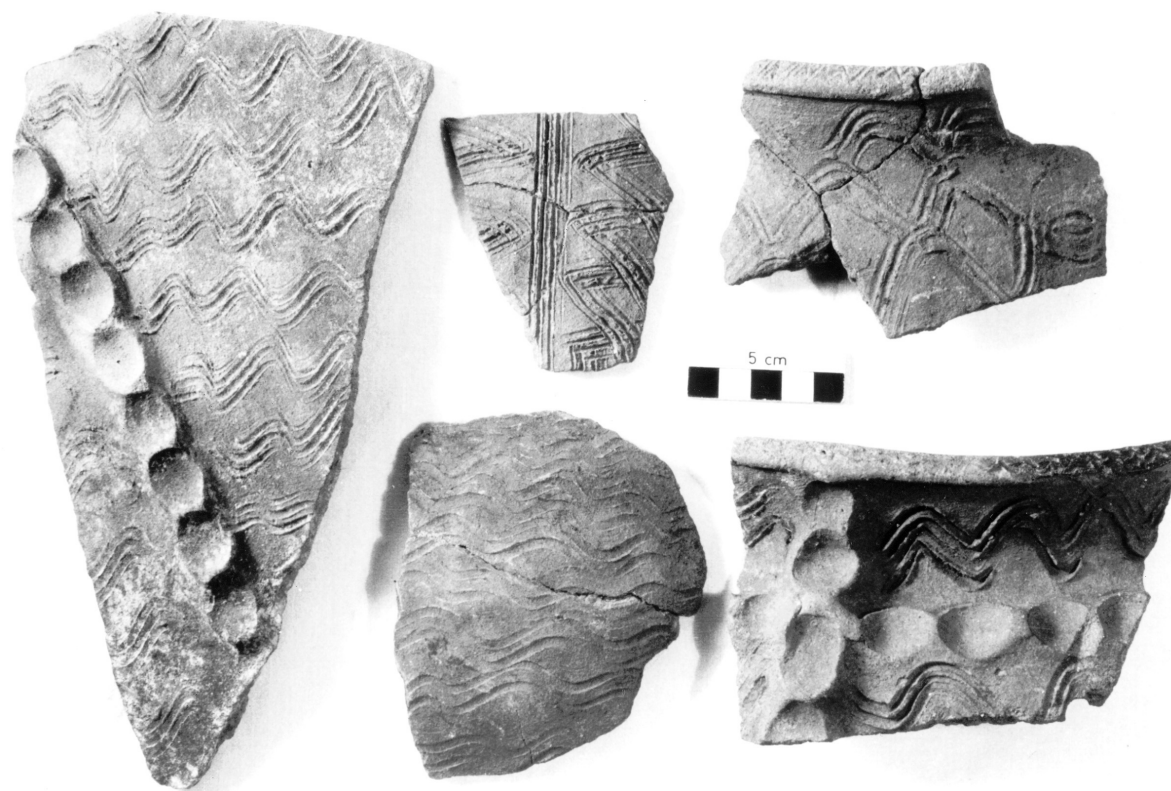

Fig 29 Early medieval sandy ware: storage jar and ?cooking-pot sherds with applied thumbed strips and/or combed decoration (centre and top right sherds from Middleborough kilns).

cooking pots/jars); this is already present on a storage-jar rim in a context of c 1100-25 (LWC GF233). Piercing nearly always occurs in linear groups of three or four small punctures, presumably made with the prongs of the same tool used for combed decoration and with which it normally occurs. It is particularly common on products of the Middleborough kilns (eg Fig 34.25 & Fig 36.82). In a few instances (Fig 24.33, Fig 26.47 & Fig 32.75), the piercing seems to have been made with a bifid or trifid terminal, possibly a bird bone. On a few examples, the same effect seems to have been achieved with a hollow plant stem (kilns, Fig 33.5).

Girth grooves, characteristic of the kiln material, occur on 3% of cooking pots/jars (or nearly 7% of all forms and sherds, by weight). Burnishing (Fig 40) occurs on 0.44% (by weight) of all forms and sherds but seems confined to pitchers or jugs. Rarer decoration on cooking pots/jars includes horizontal or spiralling grooves (Fig 25.43), incised lines (Fig 26.48, wavy; Fig 32.84 and kilns Fig 34.31, zig-zag), and at least one example with dimples on the neck (Fig 24.34), a technique more associated with Fabric 20. Stamped decoration is unknown on Fabric 13 at Colchester.

Applied thumbed strips are both decorative and functional in that they give added strength to large vessels and may be arranged in a decorative scheme. With very few exceptions (Fig 32.83), thumbed strips do not occur on ordinary cooking pots but are confined to large thick-walled forms such as storage jars and curfews. The fact that bowls never occur with thumbed strips supports this observation. Unless the sherd is large enough or sooted internally, it is not usually possible to distinguish between storage jars and curfews from body sherds alone. Thumbed strips are found

on 3.7% (by weight) of all forms and sherds (1.5% by sherd number). Scored lines, sometimes visible on either side of the strip, were either guide-lines made by the potter before attaching the strip or more likely were caused by the potter's fingernails during the latter operation. Normally thumbed strips are accompanied by combed decoration.

#### Bowls (Fig 30.54-65)

Bowls are comparatively uncommon, accounting for around 4% of all forms (by EVEs and weight) and occurring in all three varieties of Fabric 13. The earliest example from the town (Fig 30.54) comes from destruction debris associated with the demolition, c 1095, of the Anglo-Saxon church in the grounds of St John's Abbey (CAR 9, 203-218). Most bowls are wide and relatively shallow with gently curving sides and sagging bases (eg Fig 30.55 and Stratified Group 6, Fig 217.25-27, all c 1175-1200). Some have straight, almost conical, sides (Fig 30.56-58), including several examples from the kilns (kilns, Fig 39.101-104). A few presumably late examples in Fabric 13T have a constriction below the rim in the manner of some Fabric 20 bowls (eg Fig 30.59, which is also shell-dusted). Thickened flat-topped rims (types B2 & B2A) are commonest, followed by plain or simple thickened rims. More developed rims, such as everted flanged rims, occur later on (eg Fig 30.65 and Stratified Group 4, Fig 213.39, c 1225-1300). All bowls appear to be hand-made, but later examples may, however, have been finished on the wheel. One bowl from the Middleborough kilns has been improvised from a cut-down decorated jar before firing (kilns, Fig 39.106). Bowls with

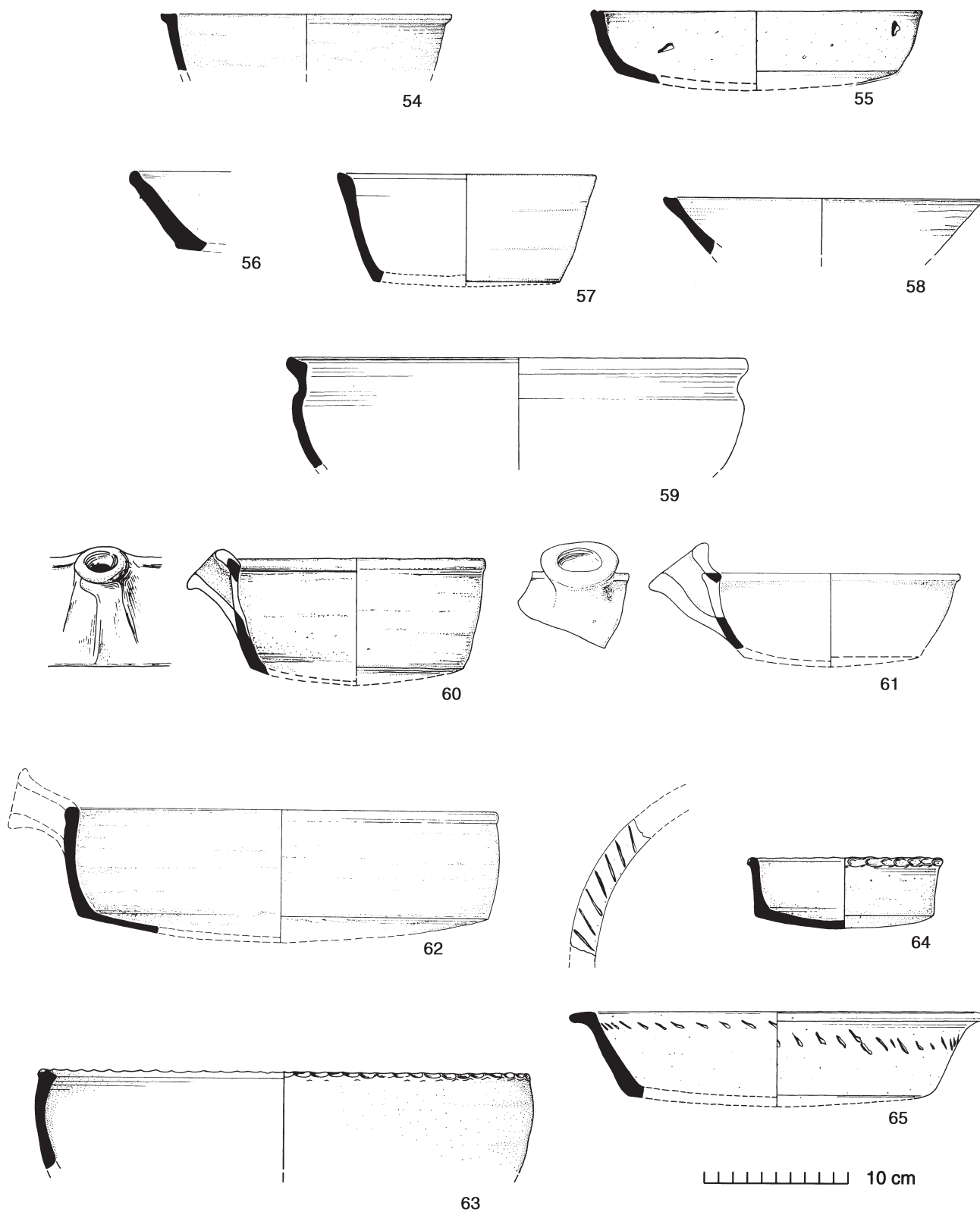

Fig 30 Early medieval sandy ware: bowls (nos 54-65; no 54 from destruction of St John's church c 1095). 1:4.

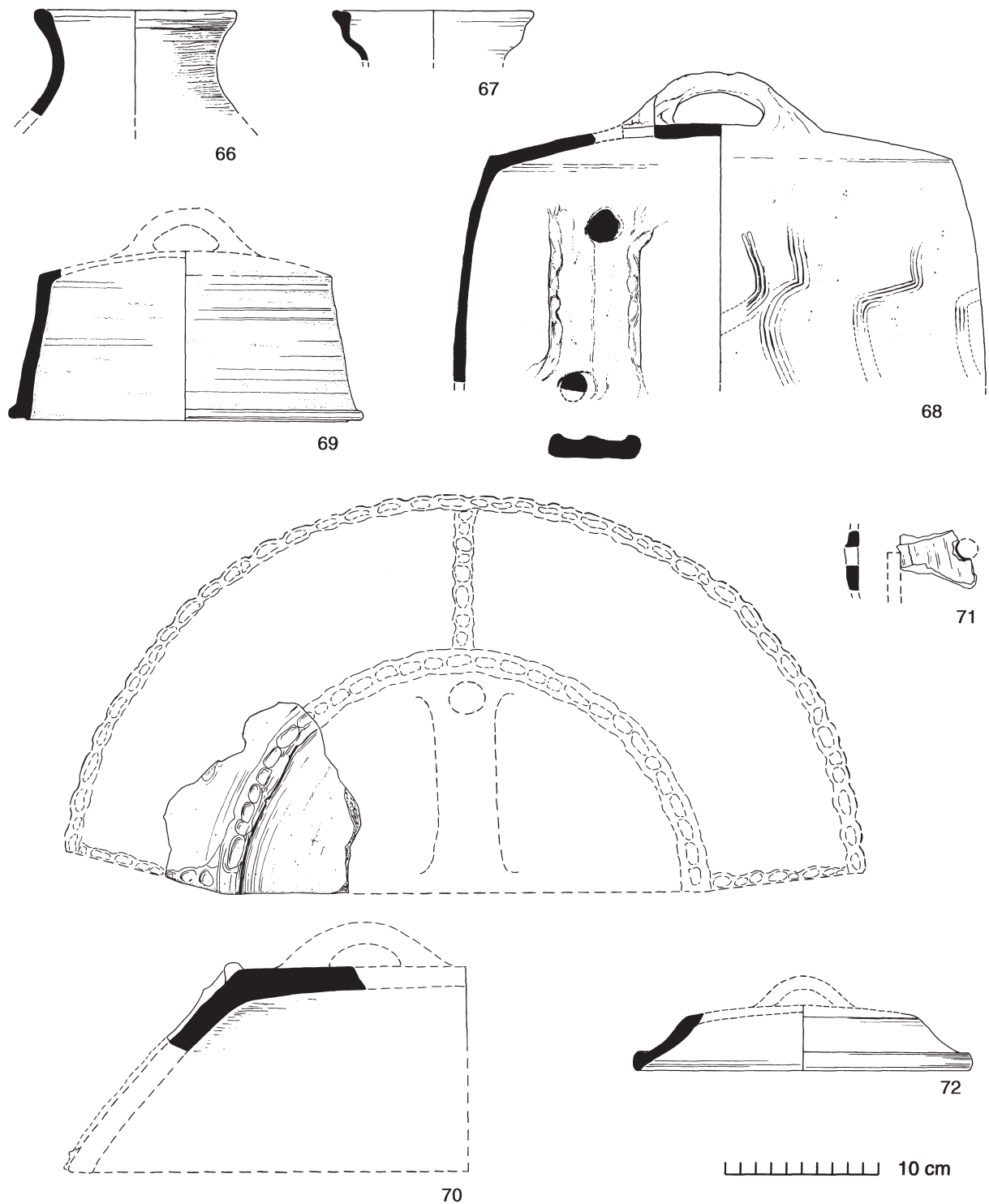

Fig 31 Early medieval sandy ware: jugs (nos 66-67); curfews (nos 68-72). 1:4.

tubular handles (Fig 30.60-61) are relatively rare with only seven or eight certain examples. Probably they are commoner than this but, without the handle, they are indistinguishable from any other bowl. Curiously, most tubular-handled bowls came from only one site on Culver Street (1.81 G), and there from a single pit complex dated c 1175-1200 (including Stratified Group 6). There is some evidence from this last complex (ie association with fish

bones) that tubular-handled bowls may have served as frying pans (see p 316). A tubular handle (with a lightly thumb lip), from another site, comes from a context of c 1100-25 (LWC GF232).

The majority of bowls are plain but thumb rim may occur (Fig 30.63-64), and stabbed or combed decoration can occur on the more developed examples but is uncommon

(Fig 30.65, and Stratified Group 4, Fig 213.39). Bowl diameters range from 100-640 mm but occur principally within the 100-300 mm range. Unlike cooking pots and jars there is no clear size preference.

#### *Pierced-lug bowls (kilns, Fig 36.90-92)*

This unusual form is probably a deep bowl rather than a jar and appears to have had three or four pierced upright lugs. The form is unique in Colchester to the Middleborough kilns where no more than three examples have been recognised. All seem to be hand-made and are decorated with an applied thumbed strip running below the rim linked to an arch-like strip over the handle perforation and continuing down the sides. The rims are flat-topped and thickened with combed or notched decoration. Combed decoration on the body was made subsequently to the applied decoration. Parallels for this form exist beyond Essex and are considered in the discussion below (p 69).

#### *Less common forms*

##### *Curfews or fire-covers (Fig 31.68-72)*

What may be the earliest curfew (Fig 31.69, Period 2) is rather small and plain, and its identification rests on the presence of heavy internal sooting near the rim. A second possible curfew, sooted internally, is known from Stratified Group 5, of c 1125-50 (Fig 215.18). There is no doubt, however, about the identification of Figure 31.68 which is sooted and came from an apparently 12th-century context. The semicircular curfew (Fig 31.70, Period 3.2) came from a layer sealing a coin lost c 1280-1320 in Building 75 (CAR 4, 66). It occurs in Fabric 13T and was presumably made by cutting a whole circular curfew in half. Semicircular curfews were made to fit against a wall hearth, unlike normal curfews which covered a central open hearth. In Britain they are quite rare, though now slightly more common than the three original examples reported by Moorhouse (1983a, 101-7). A large lump of broken pottery (grog) projects from the surface of this curfew. Another curfew fragment (Fig 31.71, Period 3.1), sooted inside, has a circular perforation and a ?vertical slot which may have been covered by a hood. Curfews were among the products of the Middleborough kilns (see below).

##### *Jugs (Fig 31.66-67)*

True jugs, with a pouring-lip and a handle, first make their reappearance in England in the late 11th century (Hurst 1976, 325). Jugs do not generally become common, however, until well into the 12th century; they are probably current, but rare, in London c 1140 (Pearce *et al* 1985, 19), and jug sherds of Heddingham ware occur in Colchester at about the same time (c 1125-50). About sixteen vessels are represented in the material from Colchester; most occur in the late Fabric 13T. At least four Fabric 13 jugs were found in, or derived from, the Middleborough kilns (kilns, Fig 41.110-113), and a similar burnished jug (Fig 31.66, Period 3.2), was found nearby, together with fragments from a burnished sagging base (Fig 40). If anything, the Middleborough jugs are cruder than their related counter-

parts, the spouted pitchers. The jugs differ from these in having taller, generally sloping necks and very simple rims with pouring-lips. Figure 41.110 (unburnished) appears to be wheel-finished whereas the other burnished kiln jugs are hand-made. Burnishing is all over externally and even, to a lesser extent, internally. Burnishing has not been recognised, so far, on any form other than jugs.

The majority of jugs, which are not from the Middleborough kilns, occur in Fabric 13T and have more developed near-triangular section rims and possibly ribbed necks. These are more typical of medieval greyware jugs (Fabric 20), and the distinction between the two fabrics at this point is sometimes vague. There is no doubt, however, about the fabric identity of Figure 31.67 (Period 3.1), ie Fabric 13. Other stratified examples (Fig 213.38; Stratified Group 4, c 1225-1300) occur in late 12th- and 13th-century contexts.

##### *Crucibles or globular lamps (Fig 32.73)*

All four crucibles/lamps are in a hard, relatively fine, fairly micaceous, sandy fabric. The outer surface has been wiped while wet and is quite smooth. They generally have dull oxidised surfaces with a grey core and inner margin; some sooting occurs externally. Rims are simple or slightly thickened (Fig 32.73). None bore obvious traces of metals and the unvitified fabric and the presence of sooting suggests they could be lamps (Justine Bayley, pers comm). However, sherds from two other vessels, which may be heavily vitrified Fabric 13 (occurring with unvitified examples), bore traces of silver on one and a mixed alloy of copper, zinc, tin and lead on the other (LWC R53). Two of the ?lamps (not illustrated) are datable to the 12th century. One belongs to Period 2.2-3 (CPS F118), and the other came from a large, timber-lined storage pit associated with the stone house in Lion Walk (Building 28) dated to the second half of the 12th century (LWC GF234).

##### *Other lamps (Fig 32.74-77)*

A cresset lamp (Fig 32.74), heavily sooted inside and with a thumbled rim, comes from a High Street context of c 1100-50. Preliminary examination of material from the nearby Angel Yard site, also on the High Street, has produced further examples. Figure 32.75, with rows of bird-bone stabbing, may be another unusually small example of this form but is unsooted. A rare, hand-made, flat-based vessel, with a crudely cut-down rim, is also likely to be a lamp although it is sooted only on the outside (Fig 32.76; Stratified Group 5, c 1125-50). Figure 32.77 from the same context is a unique conical form which is sooted internally and might be another unusual type of lamp.

##### *Miscellaneous (Fig 32.78-87)*

Inevitably, there exist a number of pieces of uncertain form and function. Those for which a reasonable interpretation exists are described below:

Figure 32.78, a very thick hand-made cylinder, could be a piece of kiln-furniture derived from the Middleborough kilns (see below), possibly a prop or separator, or perhaps even a vent from the dome of a kiln. If so, it is the only piece of kiln-furniture recovered from the kilns. The cylinder was found in a pit beneath Building 75 (early 14th century),

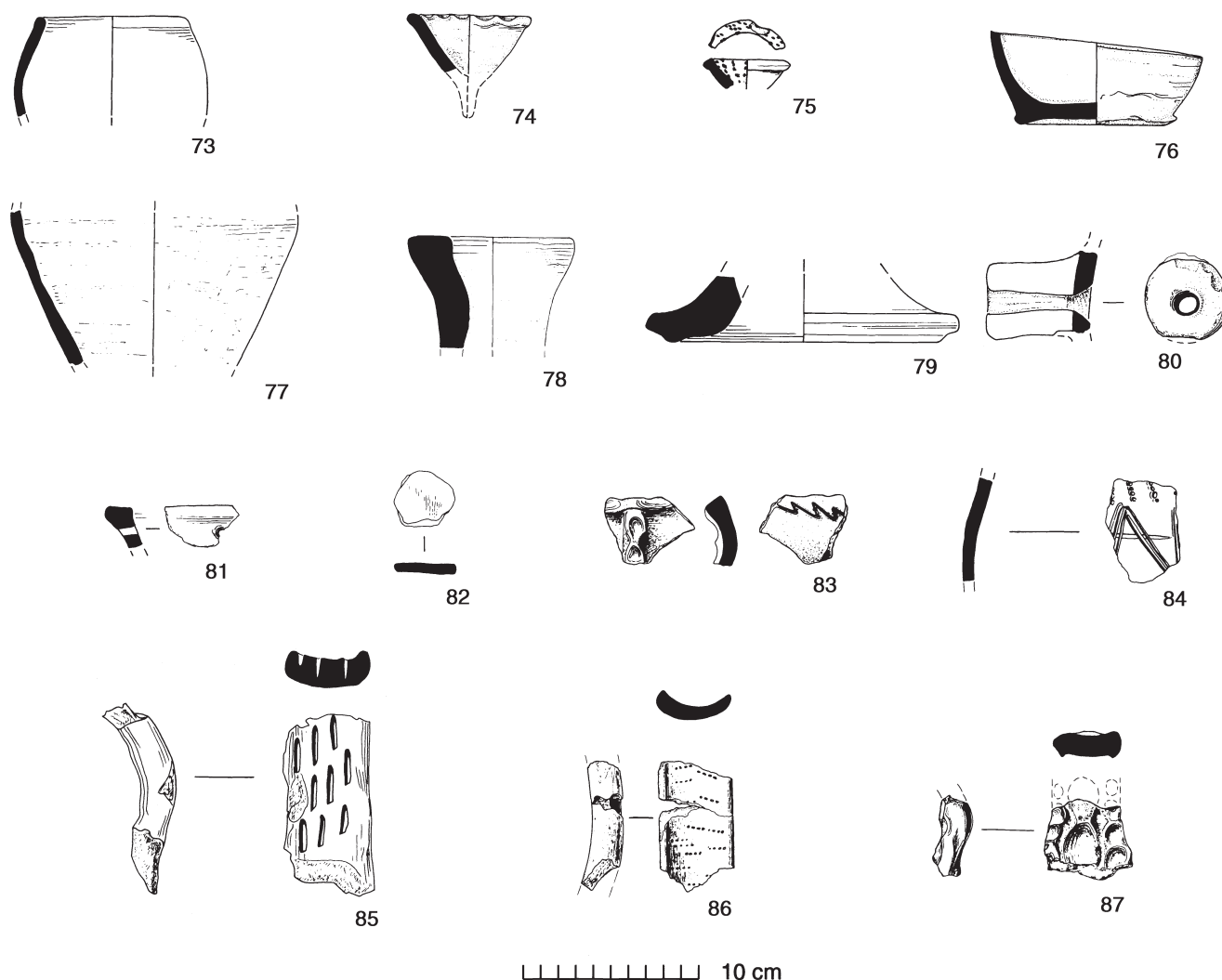

Fig 32 Early medieval sandy ware: miscellaneous forms — crucible or lamp (no 73); cresset lamps (nos 74-75); miscellaneous ?lamps (nos 76-77); ?kiln-furniture (no 78); ?chimney pot (no 79); tubular handle or ?cistern bung-hole (no 80); pierced rim (no 81); gaming counter (no 82); miscellaneous decorated sherds (nos 83-87). 1:4.

about 4 m north-east of kiln F371 and the associated building (Building 74). The same pit contained possible cross-joins with kiln F349.

Figure 32.79 (Period 2.4, c 1150-1200) is from the ?base of a similar crude hand-made cylinder in a very hard, dark grey fabric (Fabric 13T). There were no kilns from this site (Culver Street) and, although very narrow, the cylinder may be part of a chimney pot similar to decorated examples from the kilns at Mile End near Colchester (Drury & Petchey 1975, fig 11.61-4).

Figure 32.80 (Fabric 13T). Thick tubular attachment, clearly once luted on to the body of some robust vessel, quite possibly a cistern, in which case it would be the earliest example from the town; otherwise a large skillet. From a mid 13th-century context.

Figure 32.81 (Period 3.2). Rim sherd perforated before firing. Function unknown but not unique.

Figure 32.82 (Period 2) is one of three gaming counters in Fabric 13 with crudely-chipped edges. One occurs in a context of c 1150-1200 (CAR 6, 45). A spindlewhorl made from a perforated sherd of Fabric 13 also occurs in a context of c 1150-1200 (*ibid*, fig 34.1929).

Figure 32.83-87 represent miscellaneous sherds and handle fragments with unusual decorative features, some of which have been mentioned above in the discussion on decoration. Figure 32.87 is notable for its resemblance to Thetford-type jar handles.

### Textile and other impressions

Two very small textile impressions are preserved on a sherd of Fabric 13T from Long Wyre Street (COC L49, Period 3.2). The weave is plain.

Two sherds from kiln F349 preserve impressions of plants. A basal sherd has an impression of a small feathery plant with seeds, which is possibly a meadow-grass flower (*Poa*). A body sherd has a small ovate leaf impression (about 2 cm long), possibly representing common chickweed (*Silene media*) or petty spurge (*Euphorbia peplus*). Both are common weeds of cultivation.

## Medieval pottery kilns at Middleborough

[Figs 33-42]

### The kilns and related structures

Middleborough lies just outside the North Gate of the town between the Roman town wall and the River Colne. Excavations here in 1978 uncovered the remains of at least seven and perhaps as many as nine small, single-flue up-draught pottery kilns (F11, F12, F13, F349, F354, F371, F497, & possibly F495 & F553). These conform to Musty's kiln type 1a (Musty 1974, 44). A description of the kiln structures and a preliminary study of the pottery have been published in *CAR 3* (186-9, figs 172 & 174-5). The account given here supersedes the earlier pottery summary.

None of the kilns survive to the level of the firing chamber floor. In plan they are little more than horseshoe-shaped depressions, extended at the round end by a stokehole. Each had a tongue-like central clay support. The largest kiln (F349), which shows evidence of at least one rebuild, has a clay lining. The kiln walls were probably of clay with Roman tile and were found in the kilns. These may have continued upwards as a clay dome, or alternatively, the loaded kiln may have been roofed over with turves. Four of the kilns (F354, F12, F13 & F371) were orientated with their stokeholes facing east. F349 and F497 were orientated with their stokeholes to the south and, although much damaged, F11 and the sterile kiln F495 appear to be likewise orientated. The possible kiln F553 was too damaged to determine its orientation. The reasons for these orientations are unknown but in all cases the stokeholes point in the direction of the coast, perhaps to take advantage of coastal winds.

To the east of the kilns, and only 3 m from F371, stood a timber structure of uncertain plan consisting of many post-holes, stake holes and slots (Building 74; *CAR 3*, 189, figs 172 & 176). The remains of this structure produced a large quantity of pottery, almost certainly derived from the kilns, perhaps from F371. In addition to this, there were several sherds of Hedingham ware (Fabric 22), and a few sherds each of Fabric 20 (or over-fired Fabric 13) and Colchester-type ware (Fabric 21A). It is possible that the remains represent the south-east corner of a rectangular room, but this interpretation is far from clear. Both the timber structure and kiln F371 were sealed by an early 14th-century building (Building 75). There is thus good reason for believing that the timber structure was associated with the Middleborough pottery industry. As potter's workshops of this date are not very common (Musty 1974, 57), it is unfortunate that the Middleborough workshop is so uninformative.

### The pottery

The seven certain kilns produced a total of 108,745 kg of pottery (9,478 sherds, 33.67 EVEs). The bulk of this (53.6% by weight, or 42.5% by EVEs) came from kiln F349, well over twice the volume of any other kiln. Early medieval sandy ware (Fabric 13) was the only product of these kilns, although all but the least well preserved (F497) also produced a small quantity of shell-dusted ware (Fabric 13S; 2.4% of the whole kiln assemblage).

Dark grey reduced sherds predominate, but several fully-oxidised sherds occur, and intermediate grey-browns in still greater numbers. Colour variation, even within the same vessel, is not uncommon but tends to be gradual. Extreme colour variation exists between joining sherds of a few vessels (such as the spouted pitcher Fig 36.82). This may arise when a vessel stacked high up in the kiln becomes broken, due to some defect or mishap during firing, and fragments of the vessel fall to a lower part of the kiln where differing atmospheric conditions prevail (van der Leeuw 1975, 75). Overfiring is common but obvious wasters are few and take the form of warping or surface shrinkage and cracking; rims have a tendency to split along the vertical plane. The fabric is only marginally different from the 'late' Fabric 13T, and although there are many 'developed' features about the kiln material, it is still, as a whole, unmistakably Fabric 13.

Overall, the proportions of the main vessel forms from the kilns are a microcosm of those given earlier for Fabric 13. Cooking pots/jars (including storage jars, etc) account for 94.5% (by EVEs) of all forms from the kilns (compared to 92.3% of the whole assemblage), and bowls account for 5% (compared to 4.3%). Minor forms account for the remainder. As usual, ordinary cooking pots are the commonest single form (89.0%). Due to the very fragmentary nature of the material, only a few near-complete vessel profiles could be reconstructed.

#### *Cooking pots and related forms* (Figs 33-36.89 & Fig 37.93-100)

The larger cooking pots do not have very pronounced shoulders and can be quite rounded (Fig 33.8-13 & Fig 34.23 & 25). A few, however, are gently shouldered and the body has a sub-square outline, a feature which aligns it with the most common cooking pot form found in this fabric (C3). Miniature cooking pots (ie those with a diameter under 150 mm) are markedly globular; at least eight of these exist (eg Fig 33.1-2). The smallest miniature jar (Fig 34.24, only 60 mm in diameter) is highly decorated and clearly too small to have served as a cooking pot, and thus may not be from a jar form at all. The small shallow oxidised pot (Fig 33.7) is a lone example and could be intrusive.

Cooking pots, storage jars and spouted pitchers have short upright or slightly everted necks. In general, necks are more upright than on the vast bulk of non-kiln rims and this probably reflects the later dating of the kilns. The most common rim is the externally thickened, flat-topped variety with an internal bead (B2A), eg Figure 35.32-33 and 41-43. This comprises 38.3% of all cooking pot/jar rims from the kilns. Next in importance is the externally beaded rim (C1, 24.3%; eg Fig 35.36-39). This is followed by another type of externally thickened, flat-topped rim that lacks an internal bead but is often slightly hooked externally and slightly

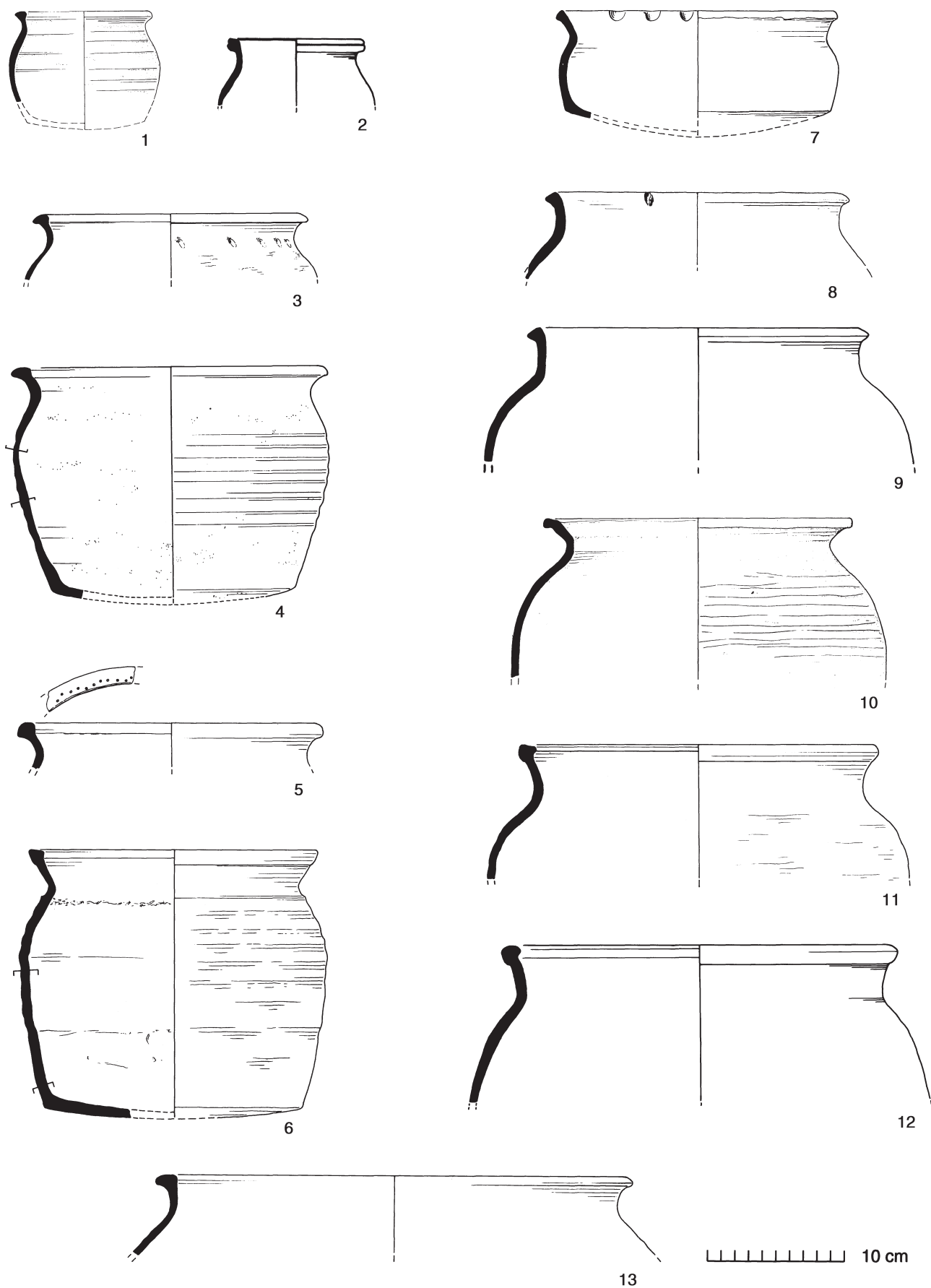

Fig 33 Early medieval sandy ware: Middleborough kilns — cooking pots (nos 1-13). 1:4.



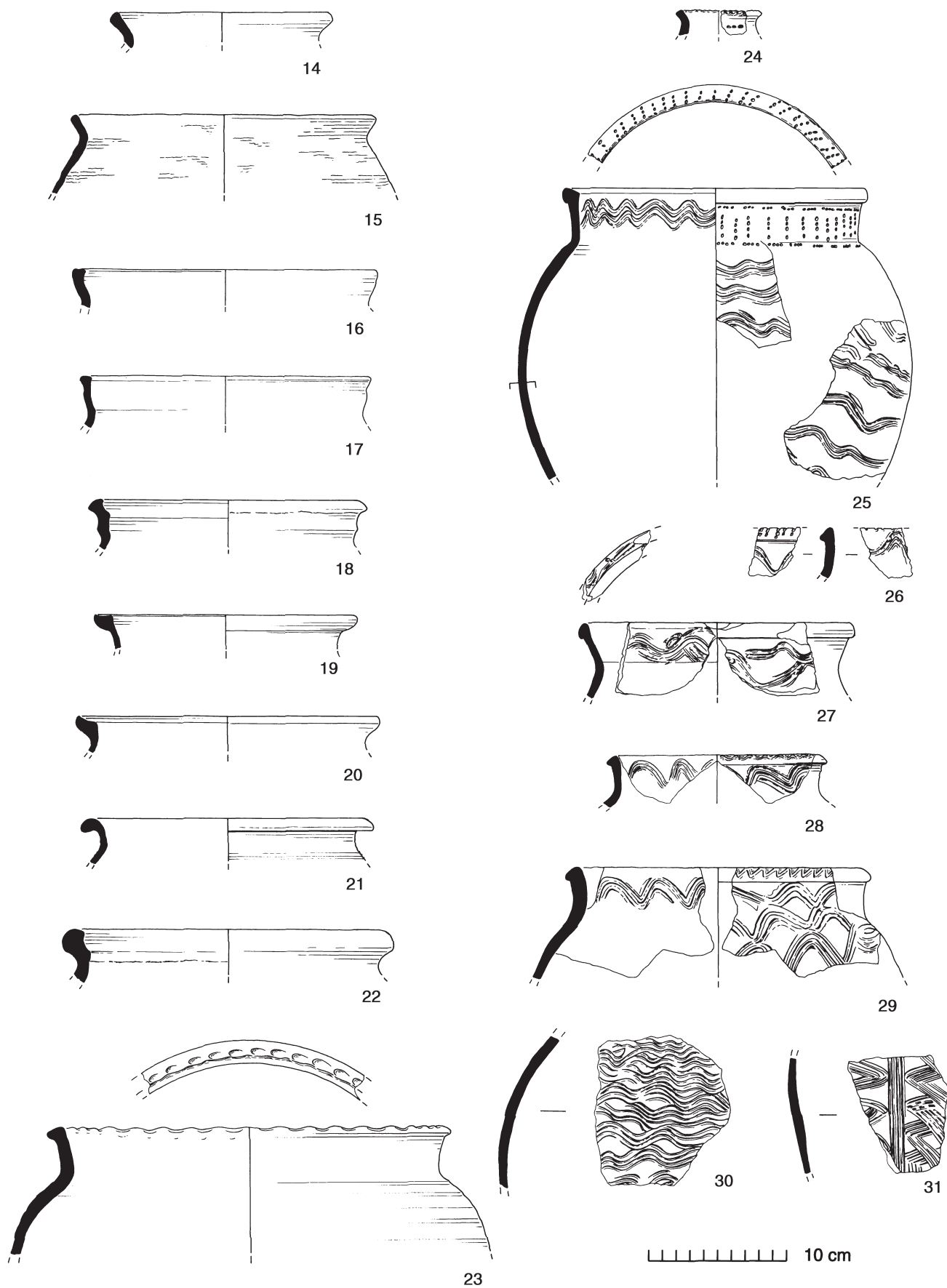

Fig 34 Early medieval sandy ware: Middleborough kilns — cooking pots (nos 14-31). 1:4.

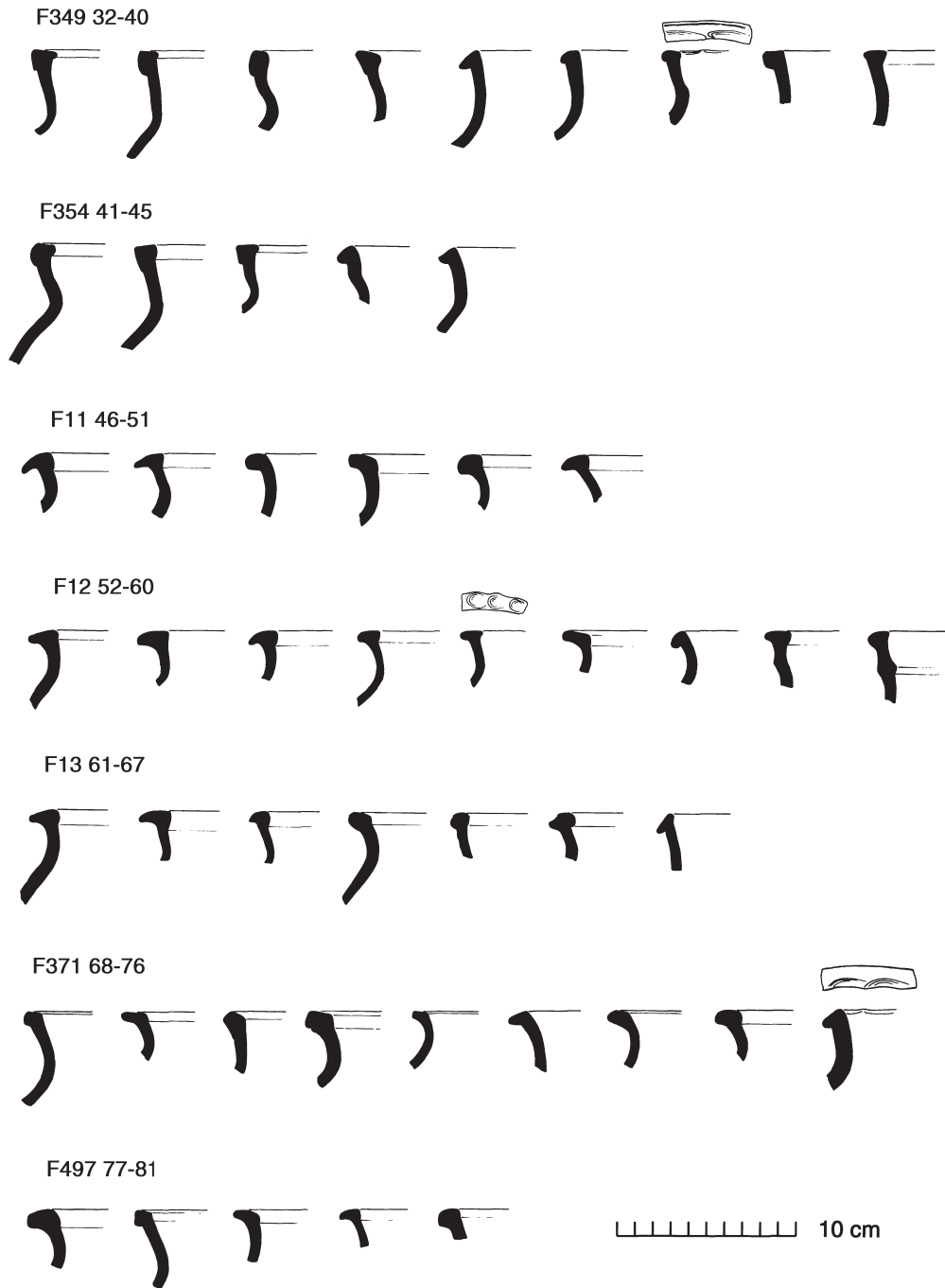

Fig 35 Early medieval sandy ware: Middleborough kilns — selection of typical cooking pot rims from each kiln (nos 32-81). 1:4.

bulbous internally (B2, 21.5%; eg Fig 35.46-49). The only other type of numerical significance is an externally beaded/ internally thickened rim (C3, 7.1%; eg Fig 35.50). The remaining 8.8% are of comparatively little significance: the plain flat-topped rims (A2) belong to the pierced-lug bowls originally thought to be a type of jar; lid-seated rims (F1) belong to the large decorated storage jars; and the remainder are either more developed or simplified variants of the more common rim types. The rim classifications used here serve to bring out the main trends in rim frequency and are, of necessity, rather simplified. Rims in particular are

often very similar in form: the 743 rim sherds progress from the most simple to the most complex with every conceivable hybrid in between. This variation is discussed below at greater length in relation to the similarity of the various kilns.

Forms other than normal cooking pots have already been described in the main catalogue of Fabric 13 forms and are not, therefore, discussed at great length here. Spouted pitchers (Fig 36.82-89) comprise 2.98% of all kiln products (assuming that the handled jars are also spouted pitchers). These occur with the externally thickened, flat-topped rim

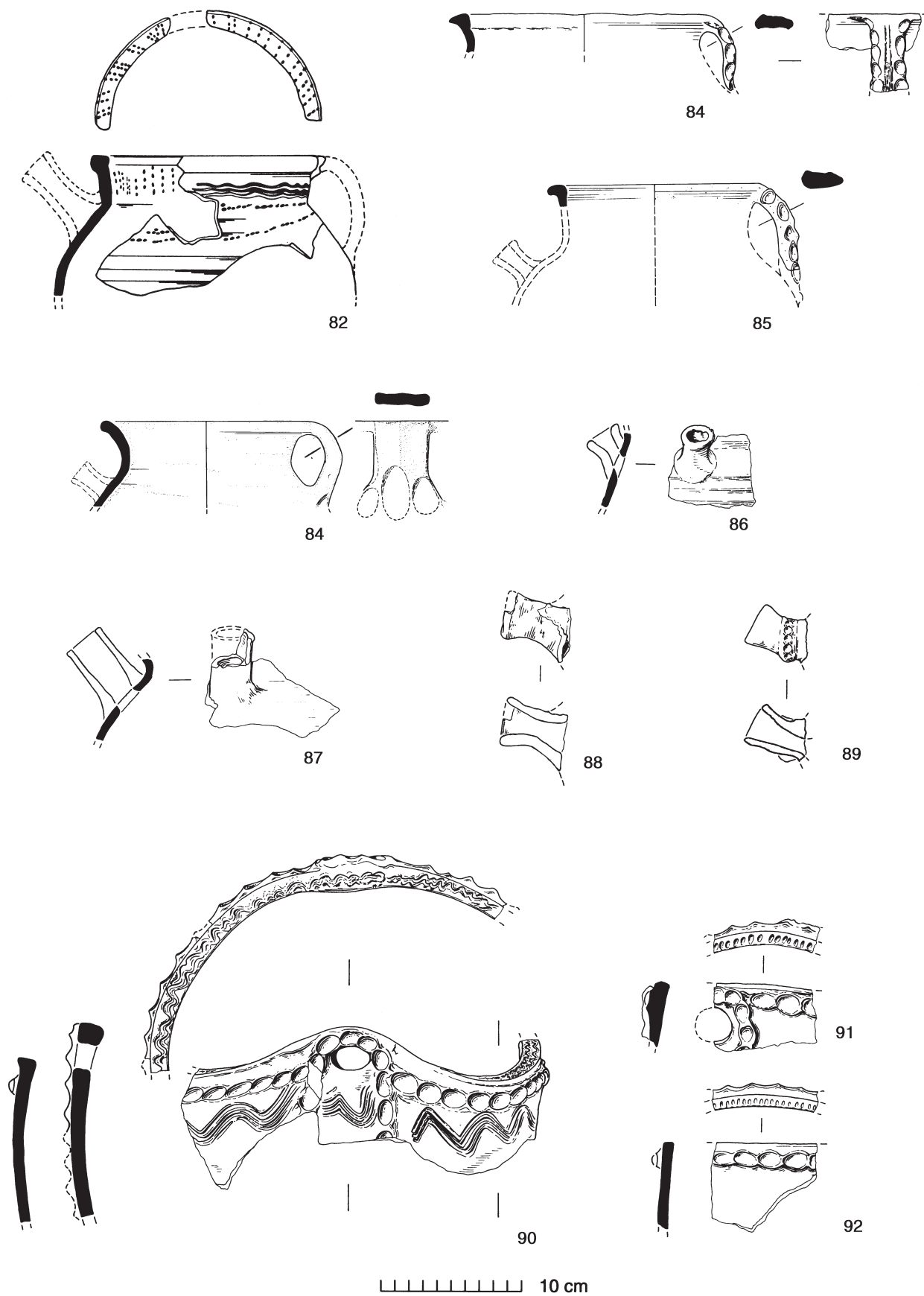

Fig 36 Early medieval sandy ware: Middleborough kilns — spouted pitchers (nos 82-89); pierced-lug bowls (nos 90-92). 1:4.

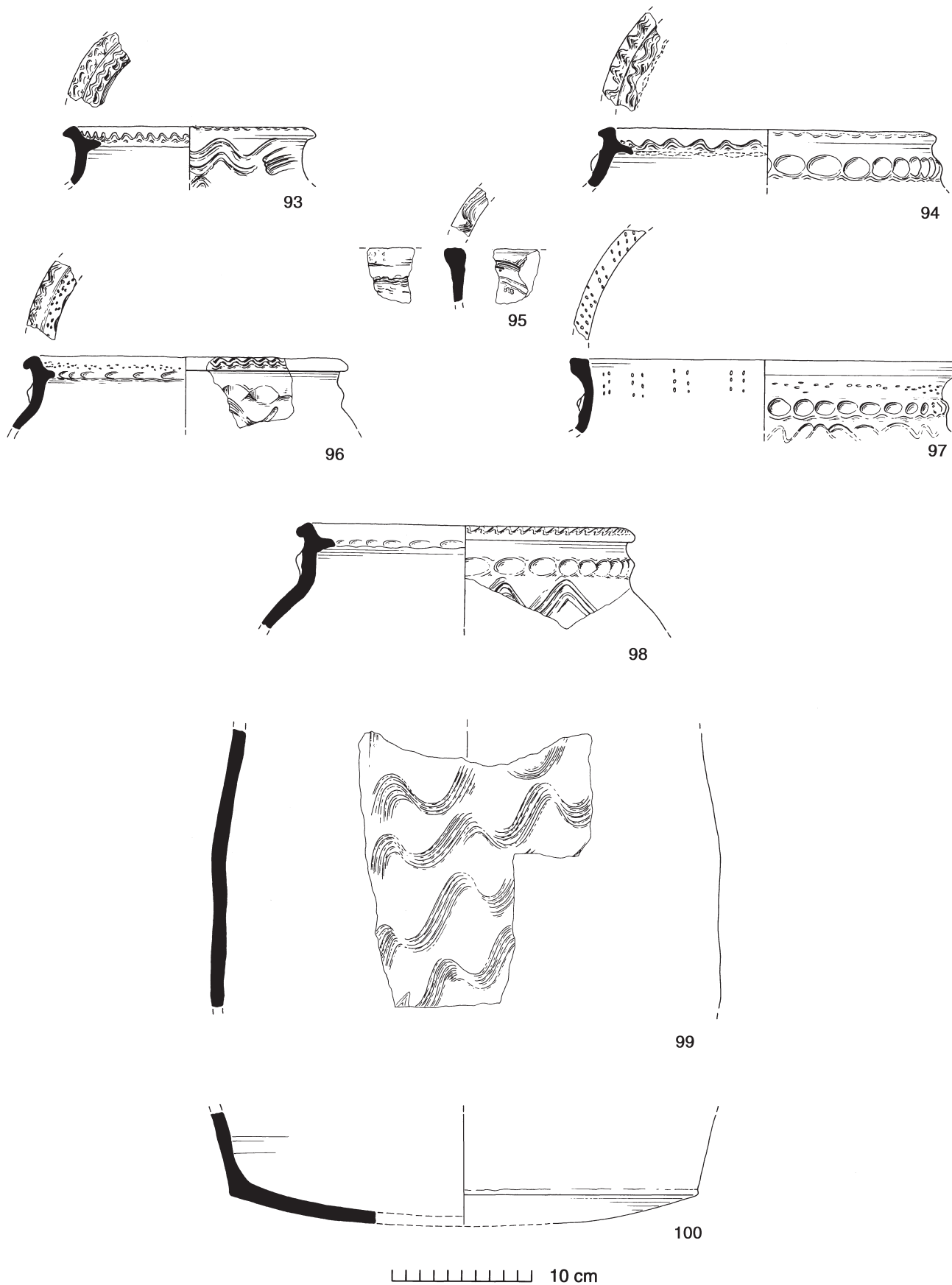

Fig 37 Early medieval sandy ware: Middleborough kilns — storage jars (nos 93-100). 1:4.

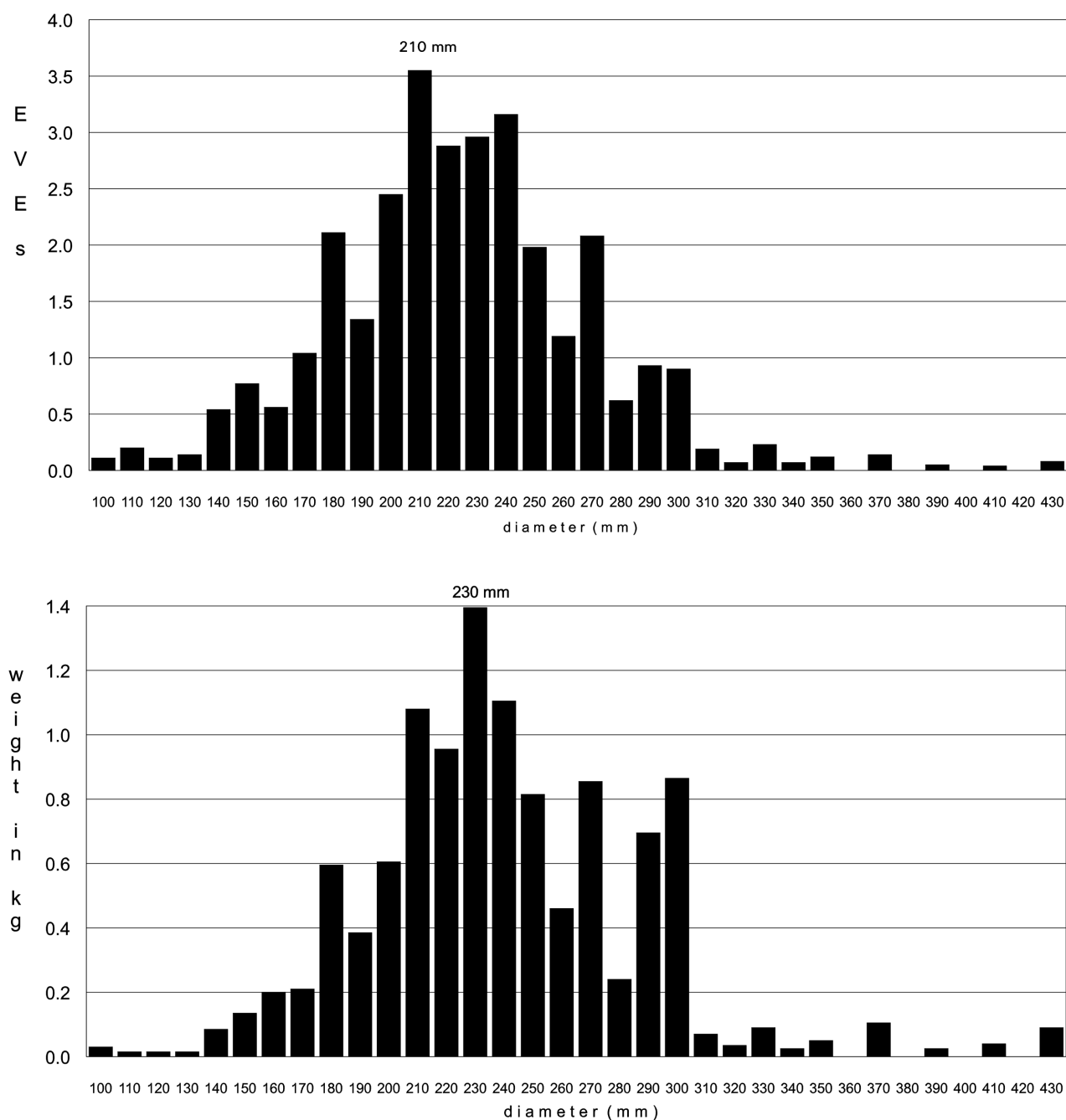

Fig 38a-b Early medieval sandy ware: Middleborough kilns — bar charts showing diameters of cooking pot and jar rims by EVEs and weight.

with internal bead (B2A), with simple and pointed variants of the thickened flat-topped rim (B2), and with plain everted rims. Handles with raised thumbled edges are characteristic of spouted pitchers from the kilns. Storage jars (0.77%) are mostly of the usual kind with a lid-seated rim (F1, Fig 37.93-100), although at least one example has a thickened rim (Fig 37.97). Some of the more highly decorated cooking pots may also be storage jars although not enough of the profile exists to be sure (eg Fig 34.29; compare with Fig 25.42). Likewise, many large decorated sherds are undoubtedly from storage jars (Fig 37.99).

The diameters of cooking pot/jar forms (Fig 38a-b) have an extreme range of approximately 100-430 mm, falling mainly within the 100-300 mm range and peaking at 210 mm. They therefore conform largely with the range already given for Fabric 13 as a whole (Fig 28), and differ only in having a slightly greater emphasis (by EVEs) on vessels of large diameter (200-240 mm), probably the storage jars. This picture is roughly the same for each kiln where the sample of pottery was large enough to make such comparisons.

*Decoration (cooking pots and related forms) (Figs 29 & 40)*

Twenty-seven per cent (by weight) of all forms and all sherds from the kilns had some sort of decoration (excluding thumbed strips). This figure is significantly higher than that for Fabric 13 (20%). The commonest type of decoration is girth grooves (4.2% by EVEs, 12.6% by weight, around 40% in each kiln by weight). These may be quite pronounced (Fig 33.4) and begin a few centimetres above the base and end at the shoulder. Combed decoration is next in importance and is noticeably commoner than usual (7.4% of EVEs compared with the normal 3.6%). Thumbed rims, normally the commonest type of decoration, have decreased dramatically in significance, dropping to 5% (compared to the overall 19.2% of EVEs). Thumbed decoration from the kilns is noticeably different from the earlier style of thumbing which was impressed deeply into a fairly simple everted rim, deforming it considerably in the process. Although a very small number of such rims was found in the kilns (possibly, like the small quantity of Roman pottery, of a residual nature), the majority of thumbed rims differ in the superficial nature of the thumbed decoration which is usually executed lightly on the upper/inner surface of a now more developed rim (Fig 34.23 & Fig 35.38, 56 & 76). Pierced or stabbed decoration is again more common than usual (4.3% compared with 1.8% of EVEs). This normally occurs with combing, and these characteristically cover as

much of the shoulder/rim zone as the potter could manage, on the outside, inside and top (Fig 34.24-29 & Fig 36.82). Applied thumbed strips occur on storage jars and, it would seem, to a lesser extent on cooking pots or spouted pitchers, an observation based on the presence of thin-walled sherds with girth grooves and thumbed strips. Thumbed strips also occur on curfews and pierced-lug bowls. Such sherds comprise 5.3% of the total weight.

*Manufacture (cooking pots and related forms)*

It is clear that the Middleborough potters were familiar with the potter's wheel or turntable, but for some reason none of the kiln vessels appears to be wholly wheel-made. Evidently the Fabric 13 tradition of hand-made bodies and wheel-made rims was continued at Middleborough and employed with considerable skill to produce some vessels of surprisingly good quality. The wheel played a secondary role in vessel manufacture. It was employed either wholly or partially to make the rim and then to smooth over the join between the rim and the body. At this point, the body was evened-up on the wheel and given its characteristic girth grooves which are rarely perfectly horizontal or regular. From within, the many dents and undulations, particularly near the base and at the rim/shoulder junction, reveal the true hand-made nature of the pot.

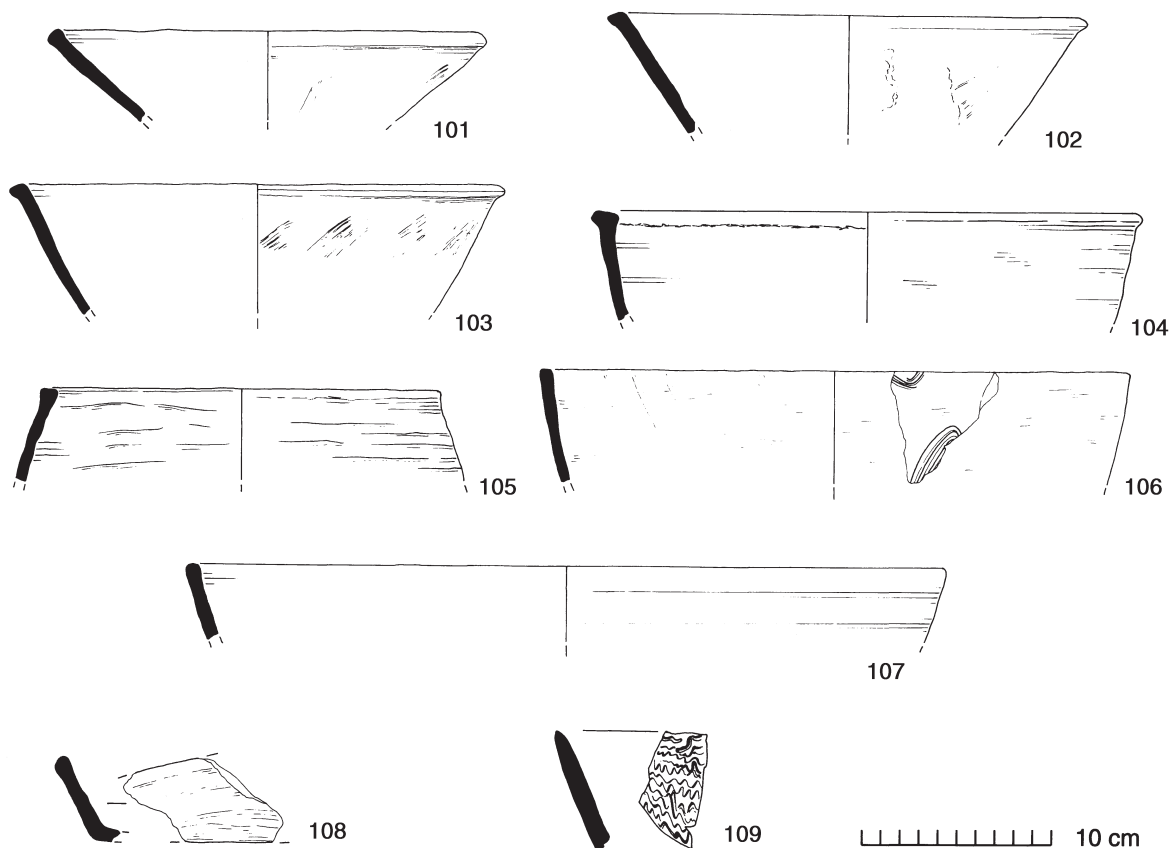

Fig 39 Early medieval sandy ware: Middleborough kilns — bowls (nos 101-109). 1:4.

*Bowls* (Fig 36.90-92 & Fig 39.101-109)

After cooking pots and related forms, bowls are the second commonest form. There are at least six and possibly as many as ten bowls from the kilns, or thirteen if the pierced-lug bowls are included. The normal type is straight-sided and almost conical with a thickened, flat-topped or beaded rim (Fig 39.101-104). All of these appear to be hand-made, and possibly tidied up on the wheel. Although plain, those from kiln F349 have a series of crude and indefinite diagonal striations around the outside which could be an attempt at decoration. Figure 39.106 (with combed decoration) and possibly Figure 39.105 are made from cut-down cooking pots at the leather-hard stage and could be considered as bowls. Figure 39.108 and 109 are crudely-made shallow bowls, trays or possibly very early dripping-pans with very uneven rims. Figure 39.107 is of unusually large diameter (approx 400 mm) and is either wheel-made or considerably improved on a wheel. Possibly this is also a bowl, tray or dripping-pan or even (though less likely) a curfew rim.

The three pierced-lug bowls (Fig 36.90-92) have already been discussed (see p 55). These singly comprise 1.72% of all forms and are unique to kilns F13 and F349.

*Jugs* (Fig 41.110-113 & Fig 40)

Jugs or pitchers with pouring-lips and handles comprise 2.15% (by EVEs) of all vessels from the kilns. At least four jugs are present. All but one of these (Fig 41.110, kiln F13)

comes from kiln F371, including the two burnished jugs (Fig 41.111-112). This was the only kiln to produce burnished sherds (17.5% of this kiln by weight), and these are almost certainly from jugs. Fragments of burnished jug handles from the town are of oval section. Figure 41.113 is the only Fabric 13 jug with combed decoration. The burnished jugs appear to be hand-made whereas the others show some degree of wheel-treatment.

*Curfews* (Fig 41.114-116)

Curfews occur in kilns F11 and F13. The fabric is noticeably coarse. It is possible that the other kilns also produced curfews, but it is almost impossible to distinguish body sherds of curfews from those of large storage jars (particularly among kiln waste where there is no evidence of use). The known curfews have fairly closely-set applied thumbled strips in a vertical fashion. If it is assumed that all large body sherds (ie without rims, etc) with thumbled strips are either from storage jars or curfews, then curfews must constitute a smaller figure than the 3.6% (weight) that these sherds comprise.

*Miscellaneous* (Fig 41.117)

Two sherds, probably from the same vessel, come from an unidentifiable vessel form, possibly a wide jar or bowl with an applied thumb-decorated horizontal cordon.

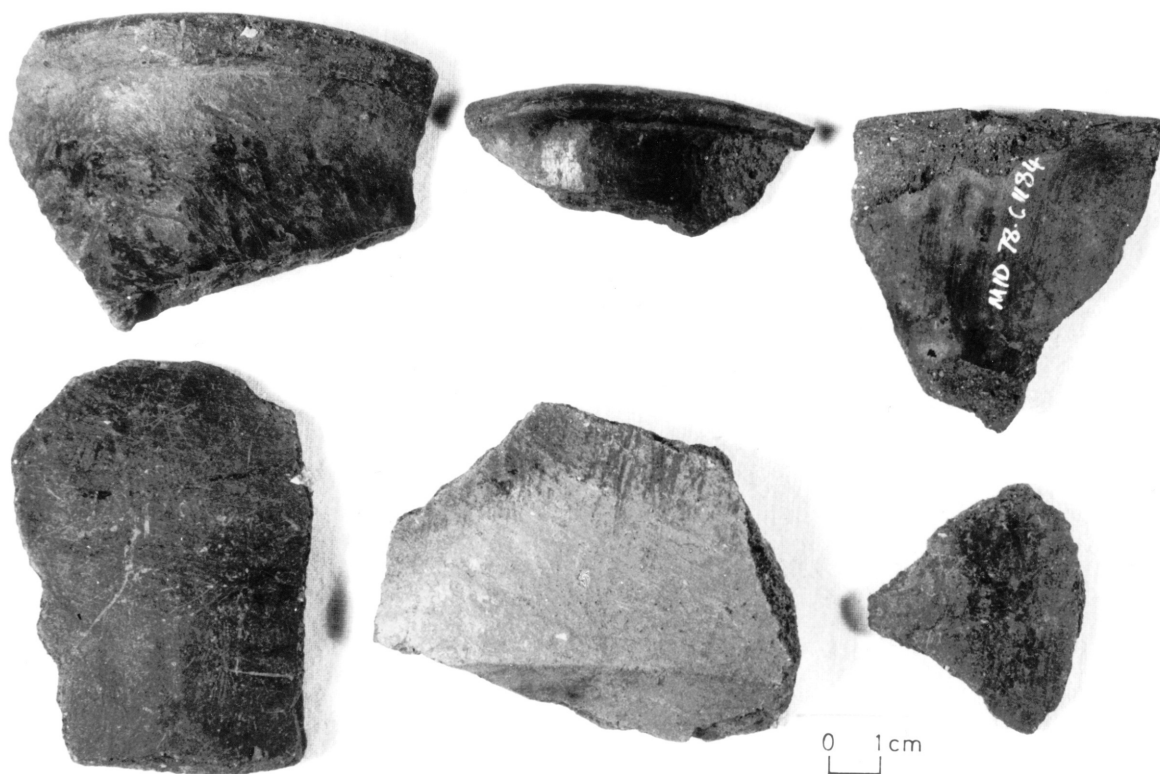

Fig 40 Early medieval sandy ware: Middleborough kilns — burnished jug sherds from (or derived from) the kilns.

**Similarity of the kilns**

[Fig 35.32-81]

Comparisons between the kilns reveal a broad division into those kilns that produced a high proportion of decorated products (F354 & F349), and those producing plain products (F11, F12 & F13). This distinction may simply be a reflection of product specialisation between kilns of the same date, or it may be a reflection of two or more groups of kilns of differing date. It is felt that this last possibility is the more likely, and that the decorated group of kilns could be somewhat earlier than the plain group.

Of the decorated group, kiln F349 cut the stokehole of F354 and so is later than it. The products of these two kilns have

much in common with each other. Rims decorated with piercing and combing are relatively common. The commonest rim in both kilns is the externally thickened, flat-topped rim with an internal bead (B2A: 53% in F354; 61% in F349). Three distinctive variants of this occurring in kiln F354 (Fig 35.41-43) occur again in kiln F349 (Fig 35.32-35).

Kilns of the plain group share several characteristics. Excluding thumbbed rims (which have a minor presence in all seven kilns), decoration is rare. Pierced decoration is absent save for one rim in kiln F11 (Fig 33.5). Combed decoration is represented by only one rim in kiln F13 (Fig 34.27) and a very small number of combed body sherds in each kiln. The commonest rim is the externally thickened, flat- or round-topped rim (B2) which accounts for between 37-53% of all the rims in these kilns. The internally

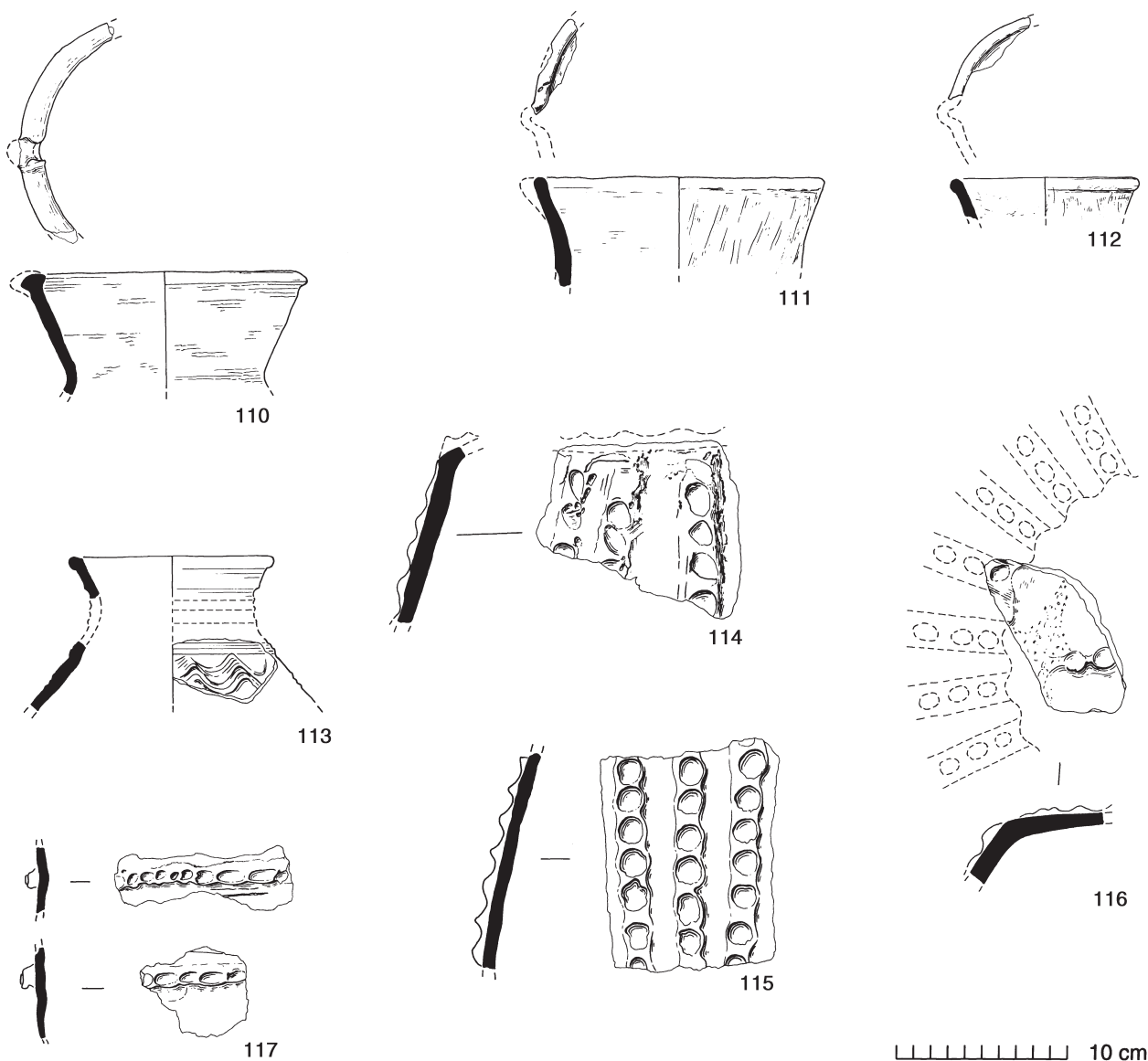

Fig 41 Early medieval sandy ware: Middleborough kilns — jugs (nos 110-113 (nos 111-112 burnished); curfews (nos 114-116); unidentified form (no 117). 1:4.



beaded rim is relatively rare, and quite unlike the distinctive varieties in F354 and F349. Most rims, however, have a slight internal thickening defined by a lightly scored line (eg Fig 35.46-55). Pointed external thickening occurring on many rims may develop into a hook-like flange (Fig 35.46-47); on others this thickening develops increasingly into a pronounced flange which begins to resemble the squared flange found on greyware Fabric 20 cooking pots (Fig 35.52-57). Pottery, almost certainly derived from the kilns and found in the potter's workshop described above, is, if anything, more developed and includes fully-developed squared flanged rims (H1).

No kilns of the plain group produced definite storage jars with the kind of lid-seated rim common to the decorated group, although they did produce some unusual complex rims which could be capable of receiving a lid (kiln F12, Fig 35.59-60; kiln F13, Fig 34.18-22). Similarly, curfews were found only in kilns of the plain group.

The remaining two kilns F371 and F497 do not fit very neatly into either of the kiln groups described above. Kiln F371 is unique in producing burnished sherds and an exceptionally high number of jugs. Although burnishing might link kiln F371 with the decorated group of kilns, its rim types, their proportions and the presence of jugs also link it to the plain group. Kiln F497 produced so little pottery that comparisons with other kilns can only be tentative. The presence of storage jars and a high proportion of decorated pieces appear to link it to the decorated group, but its rim types have more in common with the plain group and even more in common with F371. Because of these similarities, kilns F371 and F497 could, perhaps, be separated out into a third group bridging the typological gap between the decorated and plain groups of kilns.

### Dating and life span of kilns

On the basis of internal comparisons and only one significant stratigraphic relationship, it is suggested that the kilns which produced the more decorative wares (F354 & F349) are somewhat earlier in date than those which produced plainer wares (F11, F12 & F13), with F371 and F497 perhaps being intermediate in date. Despite some typological differences, there is a large degree of similarity between the products of the various kilns and also between the kiln structures themselves. All this is taken to imply that the difference in date between the earliest and the latest kiln is not particularly great.

Information on the longevity of individual medieval kilns or groups of kilns is scarce. A group of nine 13th-century kilns at Laverstock in Wiltshire is estimated to have operated over a period of 50 years, with each kiln lasting around five years (Musty 1974, 53), although more recent opinions suggest the kilns could have lasted longer (McCarthy & Brooks 1988, 46). The Laverstock kilns, however, were of more sophisticated construction than those at Middleborough and produced a more sophisticated product to supply a royal palace. Given their simpler nature, the life span of a Middleborough kiln could well be less than five years, perhaps as little as two or three years. Assuming that each kiln operated consecutively, the length of time during which the Middleborough kilns could have been in operation would be about 25 years.

A small number of sherds found in the kilns are in fabrics other than Fabric 13. Kilns F354, F349 and F371 each produced a sherd of Hedingham ware (Fabric 22); that in F349 is from a green-glazed strip-jug. The stokehole of F349 produced a fragment of a thumbled jug base in Colchester-type ware (Fabric 21A). Two more sherds of this fabric came from kiln F13, including one with a thin stroke of white slip and specks of green glaze. Kiln F13 produced, also, a sherd of shelly ware (Fabric 12) and one or two possible sherds of medieval greyware (Fabric 20). Cleaning over F11 produced further sherds from a Fabric 20 jug. Despite their limitations, these alien sherds are useful for providing a general date for the kilns, although the possibility that some represent intrusive material cannot be ruled out. Hedingham ware first appears in Colchester *c* 1140/50 and is probably not in wide circulation after *c* 1300. Fabrics 20 and 21A appear to have developed from reduced and oxidised Fabric 13, respectively, during the late 12th century, although Fabric 21A should date to after *c* 1200. Both fabrics have a long life span.

Typological comparison with excavated material from elsewhere in the town can also contribute to the dating of the kilns. Outside of Middleborough, exact parallels to rim forms and the characteristic stabbed and combed decoration of the decorated group are few and usually poorly stratified. Stratified Group 5, *c* 1125-50, provides reasonably good parallels in the form of a combed spouted pitcher and a conical bowl (Fig 215.17 & 14). The dominance of simple cooking pots with plain rims, however, suggests this group is earlier than the kiln material. Pottery from the plain group of kilns is somewhat easier to parallel. Both in character and form there are parallels between pottery from the kilns and from the upper fill of the Lion Walk ditch (Stratified Group 4; Fig 212.35, *c* 1200-25 & Fig 213.38-39, *c* 1225-1300). From a sequence of contexts of *c* 1150-1200 (LWC G, Period 2A: F81, F214 & F256), there are particularly good parallels for: the curfews from the kilns; burnished sherds; squared, and thickened, rims of kiln-type; and even a waster of the latter. On the basis of these typological comparisons and the other fabrics associated with the kiln, a date range from the second half of the 12th century to the early 13th century is suggested, perhaps within a bracket of *c* 1175-1225. The plain group of kilns would thus be broadly contemporary with the Period I kilns at Mile End (Drury & Petchey 1975). Three of the Middleborough kilns (F495, F497 & F553) were cut by robber trenches (F33 & F38). Kiln F11 was cut by two ?robber pits (F22 & F26). These features contained much pottery derived from the kilns and other pottery indicating a general 13th-century date. It seems highly probable that the robber trenches were dug to provide building material for the stone-mortared plinths of Building 75 which sealed the ?potter's workshop (Building 74) and whose westward extension partially destroyed kiln F371. After the abandonment of the kilns, the ?potter's workshop and the surrounding topsoil layer (L188) became buried by another layer of topsoil (L114). This layer contained two coins, the latest of which was a virtually unworn farthing of Edward I, most likely lost between 1280-1320 (CAR 4, 66). This layer was in turn cut by a pit (F422) associated with the earliest phase of Building 75 which was itself cut by the service room wall (F86). These relationships, the coins and the Mill Green ware from F422 (current *c* 1270-1350) suggest an early 14th-century construction date for Building 75. By this time, perhaps *c* 1300-25, the Middleborough pottery industry had been out of action for nearly a century.

**Origins and affinities of Colchester Fabric 13 and summary of main developments**

[Figs 27 & 42]

Early medieval sandy ware (Fabric 13) seems to have made its appearance at Colchester before the middle of the 11th century, perhaps by c 1025, when it was a contemporary of Thetford-type ware (c 850-1150), the dominant late Saxon fabric in the town. Unlike the latter ware, Fabric 13 vessels were hand-made, though the rims were either made separately on a wheel or turntable and then joined to the hand-made body, or the whole vessel was hand-made and trued-up on a wheel. Fabric 13 became the dominant fabric used in the town in the 11th and 12th centuries. In its later stages it was produced in simple updraught kilns in the town's northern suburb of Middleborough. The industry died out around 1225 or, more likely, it evolved into sandy medieval greyware (Fabric 20).

Although it is not susceptible to close dating, some of the more significant datable features of Fabric 13 may usefully be summarised here (see also Figs 27 & 42). By c 1100 cooking pots and bowls were well-established forms. By c 1100-1125, tubular-spouted bowls and storage jars with thumbled strips and comb-stabbed rims were also current. Spouted pitchers, lamps of various sorts and probably curfews were around by c 1125-50. Late forms such as skillets and jugs may not have been produced until c 1175. The main decorative features of Fabric 13, ie combed decoration and thumbled rims, had appeared by c 1100, as had the shell-dusted variant of the fabric (Fabric 13S). Later features of decoration, probably after c 1150, included Middleborough kiln-style comb-stabbed decoration (now on forms other than storage jars), pronounced girth-grooves, and combed decoration on the top of the rim which was often flanged or at least flattened. Thumbing on rims is usually fairly deep on the exterior of beaded rims c 1100-75 and after this more superficial, often on the top or inside of more developed squared/flattened rims.

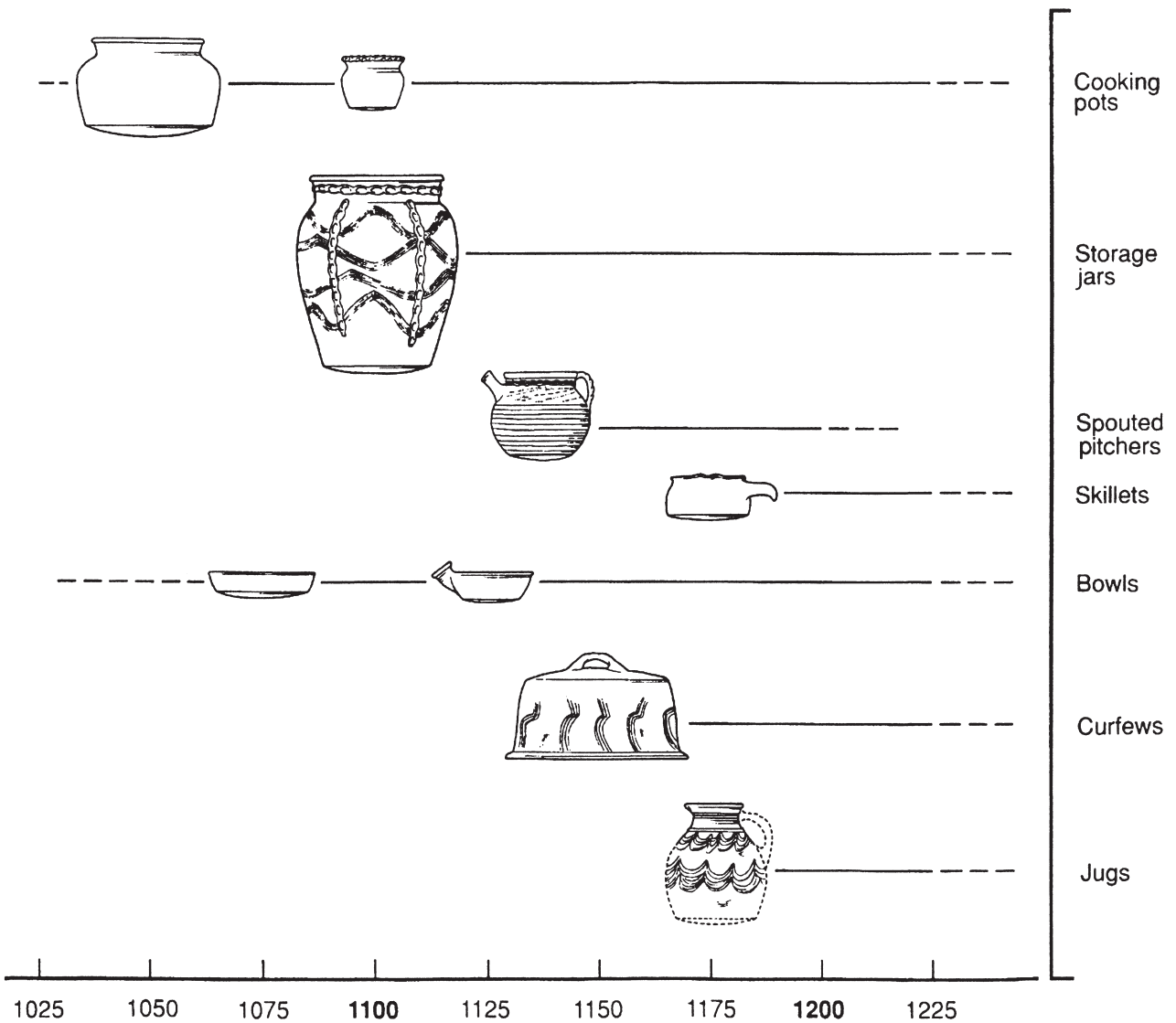

Fig 42 Diagram showing the estimated time span of the main forms in early medieval sandy ware at Colchester.

Fabric 13, as mentioned in the dating section above (p 40), is part of the wider phenomenon of (mostly hand-made) early medieval wares that appeared over much of England broadly around 1000 (Hurst 1976, 342-3). General parallels for the early medieval sandy ware forms seen at Colchester are numerous, but the simplicity of such semi-hand-made forms make most comparisons of little practical value. Comparison of decorative and typological traits holds a little more potential for establishing chronological and cultural affinities, especially with neighbouring areas where early medieval wares were produced. Ideally, more single-industry studies of this period need to be published from south-east England before parallel-searching proves more effective. To be of any real use, comparisons with neighbouring early medieval industries have been made with the following questions in mind:

- a. Where did Colchester's early medieval pottery industry come from?
- b. Which other industries was it most influenced by?
- c. Can better-dated industries assist in the dating of similar traits in Colchester's industry?

As to the first question, Colchester seems not to have had its own ceramics industry in the later 9th and 10th century. If hand-made Saxon vegetable-tempered ware (Fabric 1) did continue in production after c 850, there is no evidence to show this. However, the change from hand-made vegetable-tempered to hand-made sand- (or shell-)tempered fabrics was probably made at a number of locations in Essex at about this time. Colchester may not have been one of these locations, but Maldon most probably was as a local Fabric 13 existed here by the 10th century (Carol Cunningham, pers comm). Colchester and Maldon were the only Essex boroughs mentioned in Domesday Book. One can speculate that perhaps commerce between the two boroughs at the start of the 11th century led to the migration of a few potters from Maldon to Colchester, attracted perhaps by the recent 'urban renewal' of the latter and presumably by its expanding population and consequent demand for cheap locally produced pottery (CAR 1, 72-4).

Hand-made Fabric 13 cooking pots circulated alongside wheel-thrown Thetford-type ware brought from Ipswich eighteen miles away. Due to the increasing availability of the former and/or the demise of the latter, Fabric 13 became the dominant ceramic type in 11th-century Colchester. While cooking pots in this fabric can be seen as a development of Saxon hand-made pottery from native Essex traditions, it seems likely that more complex forms such as storage jars with thumbled strips, spouted pitchers, tubular-spouted bowls, and possibly other forms, were all copied from the more advanced Thetford-type industry and perhaps to a lesser extent from those other old East Anglian wheel-thrown industries, the St Neots-type and Stamford industries. In time, the easy availability of locally produced 'copies' or substitutes removed the need to import on a large scale from outside the area.

As for the cultural affinities and dating, there are few reliably dated assemblages of early medieval wares from Essex with which Colchester's Fabric 13 may usefully be compared. Comparisons are either too general, or the dating too vague, or else it starts too late in the 12th century (as at Writtle, and at Pleshey and Hadleigh castles). The closest local comparison is with both the sandy wares (ware B) and shelly wares (ware A) at the moated earthwork at Blunt's Hall in Witham, thirteen miles south-west of Colchester,

which may be an 'adulterine' castle of the Anarchy Period 1135-50 (Trump 1961). The shelly wares there show a range of simple, thickened, beaded and incipient beaded rims (some thumbled), and a shouldered cooking pot profile much the same as 12th-century forms at Colchester (*ibid*, fig 2, ware A, and pl iv). The sandy ware rims at Witham also include comparable beaded and thickened rims though some of these already show signs of development typical of the second half of the 12th century (ie squaring and incipient flanges; *ibid*, fig 2, ware B).

There are numerous parallels between the Middleborough kiln products at Colchester and those of the Heddingham coarseware industry located fifteen miles west of Colchester. At present, however, the Hole Farm kilns near Sible Heddingham, where Heddingham coarseware (Fabric 20D) and fine ware (Fabric 22) were produced, remain unpublished. This is unfortunate as the Heddingham and Colchester coarseware industries appear to be closely related. Small groups of Heddingham coarseware have been published (13th century; eg Drury 1976a, figs 8-9), but the start of the industry there cannot yet be established before c 1140/50 (see pp 83-4). Most of the forms seen in the Middleborough kilns, and in Fabric 13 generally, also occur at Heddingham, though there are fewer jugs at Colchester. Heddingham (Hole Farm) cooking pots can have squared rims with superficial thumbing or combed decoration on the top; comb-stabbed decoration also occurs (as at Middleborough) on the rims, outer neck and handles of storage jars.

A Fabric 13 jug with Middleborough kiln-style characteristics has been found at Highfield Farm, Bures (Suffolk), seven miles north-west of Colchester (private ownership). Although not exactly paralleled at Middleborough, the jug has a corrugated cylindrical neck with comb-stabbing on the shoulder, a raised neck cordon, and combed lattice decoration on the body. If the Bures jug is not a Colchester product there must be some additional closely-related industry serving this area, though the chances are that it is a Colchester product.

For other parallels one needs to look beyond Essex. Parallels with storage jars, spouted pitchers and tubular-spouted bowls in Thetford-type ware have been mentioned already (Rogerson & Dallas 1984, figs 160-74). On early medieval sandy ware, bands of comb-stabbing may be in imitation of roller-stamping on Thetford-type and other late Saxon wares. The distinctive bowl from the Middleborough kiln with pierced upright lugs (Fig 36.90) has parallels in several early medieval industries. There is an example in late Thetford-type ware from Great Yarmouth, Norfolk in a phase dated c 1175-1225 (Mellor 1976, fig 54.23). The form also occurs at a production site near Denham, Buckinghamshire where it is probably 12th century (Farley & Leach 1988, fig 17.9-10). Better parallels, with applied thumbled strips, occur at London in Early Medieval Sand and Shell-tempered ware (EMSS; Vince & Jenner 1991, fig 2.39, no 88) and Early Medieval Shelly ware (EMSH; *ibid*, fig 2.47, no 113); both these fabrics have a currency from the early 11th to the mid 12th century. At Canterbury, in Kent, there are also rare examples of this form in local shelly fabrics from late 12th-century contexts (EM3A; unpublished).

The development of rim forms on Canterbury Early Medieval Sandy ware (Canterbury fabric EM1, probably made at Tyler Hill) appears to have been more extensively

researched than for any other early medieval ware industry in south-east England. This is due to the presence of a number of pottery assemblages with associated documentary dating, and other assemblages with close stylistic resemblance to the former (Wilson 1982; Macpherson-Grant 1982, 1990 & forthcoming). These Canterbury wares provide some useful parallels for the dating of early medieval sandy wares at Colchester and elsewhere, and although it cannot be assumed that the appearance of individual traits at Canterbury was simultaneously marked by their appearance in other industries, it does probably serve as a reasonable indicator for the south-east at least.

Late 11th-century cooking pots at Canterbury are wide, sagging-based, globular vessels with a rounded shoulder and a distinctive straight flaring neck ending either in a variety of simple thickened or beaded rims, of which the commonest are an externally flattened D-shaped bead (eg at St Gabriel's Chapel in Canterbury Cathedral, c 1070; Macpherson-Grant 1990, fig 60.27, with thumbled rim), and a distinctive internally bevelled rim (eg *ibid*, fig 60.30, c 1070 & fig 61.31, c 1070-96). These rim types also occur at Colchester in early medieval contexts but are not particularly common, eg the flattened bead occurs at Colchester Castle in a context of c 1050-75 (CAR 1, fig 34.80, and in Stratified Group 4, c 1075-1150, Fig 210.17). Furthermore, the flaring rim with internal bevel occurs in Stratified Group 3 (c 1000-1050, Fig 20.1) and Stratified Group 4 (c 1050-75, Fig 209.2); it also occurs on a shell-dusted cooking pot (Fig 20.3) and so must continue after c 1100. In general, however, cooking pots at Colchester do not have such pronounced flaring necks. This is either because the vast majority of Fabric 13 cooking pots excavated date to the 12th century rather than the 11th century, or because flaring necks and internally bevelled rims are a more south-easterly feature; they are seen for instance on Early Medieval Sandy ware at London which has a mainly 11th- to mid 12th-century currency (Vince & Jenner 1991, fig 2.33, no 48.50).

Early medieval sandy ware assemblages of the mid 12th century at Canterbury show the demise of the flared neck on cooking pots and its replacement by more upright or gently everted necks, like the majority of those from Colchester. The most important mid 12th-century assemblage from Canterbury is that sealed by the Aula Nova in the cathedral precincts, constructed c 1160/5 (Macpherson-Grant forthcoming). This sequence of deposits shows the presence, probably by c 1140-50, of larger beaded or club-like cooking pot rims, sometimes with superficial thumbing, and often with an external point or hook and an internal beading. These club-like rims are typical of Canterbury cooking pots of the second half of the 12th century. Late 12th- and 13th-century groups show these club-like rims becoming progressively 'flat-topped' until the squared flanged rim of early 13th-century wares is finally achieved c 1175-1200.

This sequence of events appears to occur in Essex as well, though perhaps in places lags a decade or two behind Canterbury. Parallels with London are harder to draw for the period c 1150-1200. This could be due in part to the greater number of sources supplying London with cooking pots and the consequent difficulty of seeing a clear trend. Club-like rims are present on Colchester cooking pots, at least by the last quarter of the 12th century (Fig 24.33-34), and particularly on products of the Middleborough kilns, where the progression from flattened bead or 'club' to incipient flange

can be clearly seen (eg Fig 35.46-81). Similar cooking pot rims occur over much of Essex at about the same time, eg at Rivenhall (Drury *et al* 1993, fig 39.37), at Pleshey Castle (Williams 1977, fig 31.8-10 & fig 32.21-8), and in Heddingham coarseware (Walker 1991b, fig 16.4). A similar sequence of events affected other early medieval industries in East Anglia and beyond.

That some quite simple thickened and beaded rims persisted on the latest Fabric 13 cooking pots is demonstrated by many examples from the Middleborough kiln. Figure 34.23, for instance, with its simple bead and superficial thumbing on top, is very closely paralleled by several examples from the Tower of London in a context of c 1220 (EMSS; Redknap 1983, fig 11.83-92).

Combed decoration, while present in the 11th century, became a marked feature of the Middleborough kiln products in the later 12th century, particularly in combination with comb-stabbed decoration, concentrated mainly in the rim area. Combing and comb-stabbed decoration on the inside of jar rims (eg kilns, Fig 34.25-29) is a recurrent and distinctive feature at Colchester, though it was never very common. This is already present in the town c 1050-75 at Colchester Castle (CAR 1, fig 34.82). There are few early medieval industries in south-east England where such extensive use of combed and stabbed decoration can be paralleled, and the internal rim/neck decoration is difficult to parallel outside of north Essex (though it is quite common in Devon and Somerset). All these features can be seen on Heddingham coarseware in the late 12th century, particularly on large storage jars. Rims with internal combing also occur at Saffron Walden and Elmton in the north-west corner of the county (Cunningham 1982b, fig 42.21 & fig 43.25; Couchman & Eddy 1979, fig 21.19). Beyond Essex, these features are best paralleled in Buckinghamshire and Hertfordshire. The extensive use of lattice-combed decoration on an Early Medieval Chalky ware vessel from London (Vince & Jenner 1991, fig 2.54, no 137) is reminiscent of jars from the Middleborough kilns (eg kilns, Fig 34.29-31) and the Bures jug mentioned above. The former fabric probably comes from the St Albans area (Hertfordshire), where it is common in the late 11th or early 12th century and which continued to supply London until c 1150 (*ibid*, 70-72).

A 10th- to 11th-century jar from Walton in east Buckinghamshire is combed on the inside of the neck, on top of the rim and on the body outside in exactly the same fashion as many Colchester jars (McCarthy & Brooks 1988, fig 91.277). In south-east Buckinghamshire, the early medieval wares produced at the kilns near Denham, mentioned previously, also included storage jars with ledged rims and thumbled strips similar to those from the Middleborough kilns (Farley & Leach 1988, fig 19.6-8). Other, more unusual storage jars produced at Denham had slightly flaring cylindrical necks, ledged rims and external stabbed decoration (*ibid*, fig 22.1-2). These could not be paralleled elsewhere in Buckinghamshire, but this form and decoration are closely matched at Colchester (Fig 25.39-40). Many other less obvious form and decoration parallels with Denham are evident. The significance of shell-dusted ware (Fabric 13S), one of Colchester's most distinctive early medieval products, is only poorly understood. This fabric variant had appeared by c 1100 and was in marked decline by c 1175, but may have lingered on a very small scale into the early 13th century. Apart from Colchester, the only other location where shell-dusted wares are known to have been produced was at the Tyler Hill kilns near Canterbury, Kent

(Macpherson-Grant 1981 & pers comm), where the ware was in production from *c* 1175 to *c* 1250. Clearly the Tyler Hill fabric is too late to have influenced events in Colchester. Like Colchester, however, Canterbury lay near the fringes of an extensive shelly-ware domain, which seems to have stretched along the Thames estuary as far as London and then along the opposite (Essex) side of the estuary as far as Colchester. At both locations, perhaps, though at slightly different dates, shell-dusted wares may have been produced with the intention of keeping true shelly wares from flooding the local market in areas where (perhaps for geological reasons) true shelly wares could not be produced on a commercial scale.

The distribution of shell-dusted wares in Essex has not been established. Cooking pots with 'superficial shell' (sometimes recorded as Essex Fabric 12C) have been reported from Asheldham in the Dengie peninsula (Walker 1991a, 29) and at Rivenhall (Drury *et al* 1993, 78). A beaded-rim cooking pot in a shell-dusted fabric has also been found at Duxford, Cambridgeshire (Cambridge Archaeology Unit). Whether these more distant occurrences

of shell-dusted fabrics represent traded Colchester products or more local industries has yet to be established.

In conclusion, the evidence of parallels provides few definite answers as to the origins and affinities of early medieval sandy ware at Colchester, but it does provide some useful clues. The industry seems to have grown out of native hand-made Saxon pottery traditions, probably re-introduced to the town in the early 11th century, just possibly from Maldon. In the course of the 11th century, perhaps late in the century, the pottery industry was probably influenced by the declining late Saxon wheel-thrown industries, Thetford-type ware in particular. Thereafter Colchester's pottery industry developed on similar lines and at a similar pace to most other early medieval ware industries in south-east England. Evidence for 'cultural' affinities, beyond the loose copying of Thetford-type ware, appears limited. If there were other typological/cultural affinities, outside the obvious similarities with the Heddingham coarse-ware industry of north central Essex, then these lay to the west with the east Chiltern areas of Buckinghamshire and Hertfordshire rather than southwards with London and Kent.

## Chapter 4. English wares: medieval (c 1200-1550)

### London-type ware (Fabric 36)

[Figs 43-44]

Weight: 2.430 kg

Number of sherds: 127

EVEs: 0.23

This ware has already been the subject of a detailed survey (Pearce *et al* 1985) which renders it necessary only to illustrate some of the more interesting pieces from Colchester and to describe the types present here. Its occurrence here is minimal, but represents a standard cross-section of London-type ware. Both the 12th-century and the mainly 13th-century fine-ware fabrics are present. The fabric is

basically sandy with characteristically dull reddish-brown surfaces and a grey core. Clear or green-flecked glaze is common, often over a white slip (*ibid*, 2-5). It is usually finer and duller than Colchester-type ware, but brightly oxidised London fine ware has on occasion been confused with Hed-ingham ware.

London-type ware (LCOAR & LOND) is now thought to have been in circulation (in London at least) during the mid to late 11th century, but it is uncertain whether jugs were produced in this fabric as early as this (Vince & Jenner 1991, 83-5). It was not very common until c 1140; it reached full production and widespread distribution in the 13th century and ceased production by the late 14th century (Pearce *et al* 1985, fig 7; 127-37).

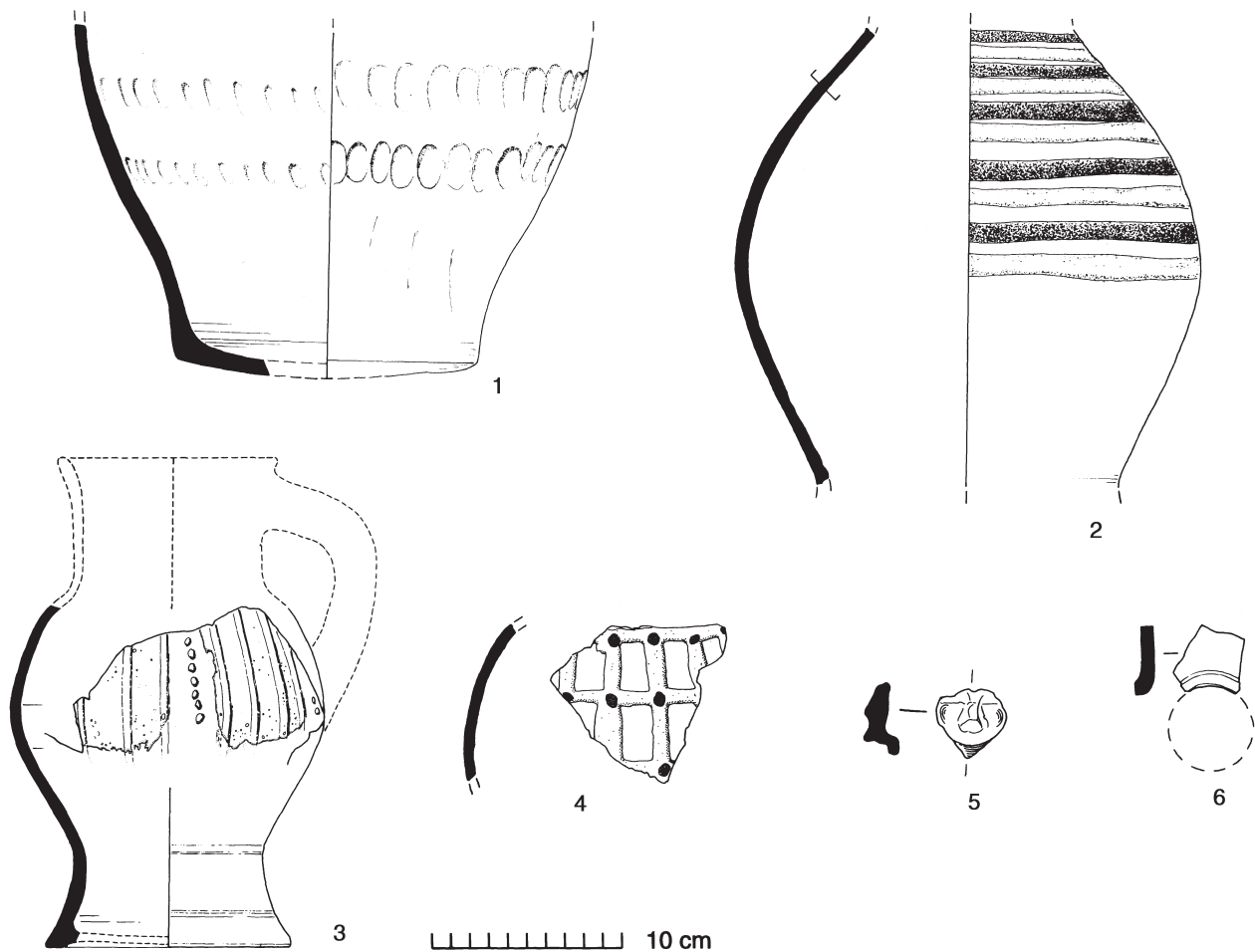

Fig 43 London-type ware: early rounded jugs (nos 1-2); Rouen-style baluster jug (no 3); decorated jug sherd (no 4); anthropomorphic jug spout (no 5); louver aperture (no 6). 1:4.

## Form and decoration

All of the main styles of London-type jug are present at Colchester, including 12th-century early rounded jugs which had not been recorded when the London-type survey was compiled (*ibid*, fig 1; p 7).

### 1. Early rounded jugs (Fig 43.1)

Six sherds in Coarse London-type ware (LCOAR) come from early rounded jugs with heavily rilled necks. Most have an external white slip under a splashed glaze. One example has an applied lattice decoration in white slip almost identical to plate I in Pearce *et al* 1985, while another has applied scales in the body clay beneath a green glaze as figure 17.28 in Pearce *et al* 1985.

The other jugs occur in London fine ware (LOND), and include Figure 43.1 with its rows of horizontal thumbing thumbed directly into the body clay and covered with a clear glaze with green flecks (as *ibid*, fig 18.32). The precise form of Figure 43.2 is uncertain and it could come from a rounded jug or a Rouen-style baluster jug. It is decorated with horizontal strips of red and white clay, and, although this scheme is not exactly paralleled in the London material, it is commonly encountered on Hedingham ware. Its identification as a London-type product is, however, not in question (Alan Vince, pers comm, 1987).

### 2. Squat jugs

Several sherds of this form occur. The base of one came from the Lion Walk ditch section (LWC NF2105; Fig 213.37, Stratified Group 4, c 1225-1300). This has a recessed base with lead pellets embedded in the underside, and on the outside are traces of applied vertical strips in very high relief. Another vessel (LWC GF81, Period 2.4, c 1150-1200) is decorated with a lattice pattern of red horizontal and white vertical strips which is exactly paralleled, but in reverse, by a London example (Pearce *et al* 1985, fig 20.39).

### 3. Rouen-style baluster jugs (Fig 43.3-4)

This type is characterised by red-painted zones outlined with contrasting squeezed strips of white clay and studded with white pellets. It is the commonest variety of London-type ware occurring at Colchester, there being at least fourteen vessels represented. The classic Rouen-style decoration is represented (Fig 43.3, Stratified Group 7, c 1225-1275; cf *ibid*, fig 30.78), and also some of the less common designs at London (Fig 43.4; *ibid*, fig 31.84).

### 4. Other jug types

These are represented mostly by small fragments. Among these are jugs in the North French style with red strips, sometimes rouletted, applied over an all over white slip under a green glaze (*ibid*, fig 40, fig 51.182-3, *passim*). Only tiny fragments from jugs in the highly decorated style survive, such as a sherd (possibly from an *aquamanile*) with an applied bunch of grapes in white clay, terminating in a decorative strip (LWC DF74; *ibid*, fig 41.142, 43.145). Figure 43.5 (residual in Stratified Group 11, c 1425-1475) comes from the spout of an anthropomorphic jug, and is

unslipped, with external green glaze (*ibid*, fig 56.215 & 222). Fragments of white slipped and green glazed rod handles probably come from tall tulip-necked baluster jugs (*ibid*, fig 37), and there is a complete example of this form in the Colchester Museum (Acton Collection, no accession number). Angular combing occurs on a couple of other fragments (LWC JF86), a common and long-lived technique on London-type ware (*ibid*, fig 61, 267-71).

### 5. Other forms

The only non-jug form identified was a circular louver aperture in London fine ware with a clear external glaze (Fig 43.6; *ibid*, fig 83; Alan Vince, pers comm, 1987). It was found in the same context as fragments of a louver in local sandy greyware (Fabric 20; see Fig 66.65-66), and is of interest in showing that at least some of the more unusual (and bulky) London forms also travelled. No London-type coarsewares, cooking pots, bowls, pipkins or similar vessels have been identified from Colchester.

## Dating and discussion

[Fig 44]

London-type early rounded jugs appeared c 1140, became common c 1150-70, and lasted into the start of the 13th century (*ibid*, 127, fig 84). Rouen-style baluster jugs were first produced c 1210, or slightly earlier, and are current throughout the first half of the 13th century (*ibid*, 131-2, fig 86). The North French style also appeared c 1210 but, along with the highly decorated style, it is more typical of the mid 13th century and early 14th centuries (*ibid*, 135, fig 87).

The evidence from Colchester is entirely consistent with this. Period 2.4 (c 1150-1200) produced sherds of a large early squat jug, together with a fragment of base apparently from a (Rouen-style) baluster jug. In Period 3.1 (c 1150/1200-1250/75), Rouen-style baluster jugs dominate the London-type assemblage, and the North French types, always a minority, do not appear until Period 3.2 (c 1250/75-1400). At its peak, in Periods 3.1 and 3.2, London-type ware never formed more than 0.48% (by EVES) of the assemblage.

Minor though its presence may have been, London-type ware appears to have had a profound effect upon contemporary and emerging Essex glazed ware industries. The contemporary Hedingham ware industry was deeply influenced by developments in London-type ware and appears to have evolved through the major London trends from early rounded jugs to Rouen-style baluster jugs and finally North French style/highly decorated jugs. Colchester-type ware (Fabric 21A) also appeared in time to reflect the fashion of Rouen-style jugs.

It also seems likely that the style for all over white slipped vessels under a green-flecked glaze was introduced to Essex by the influence of London-type ware. This style, which was embraced by all but the Hedingham industry, became a major characteristic of medieval Essex slipware industries including Colchester-type ware and Mill Green ware.

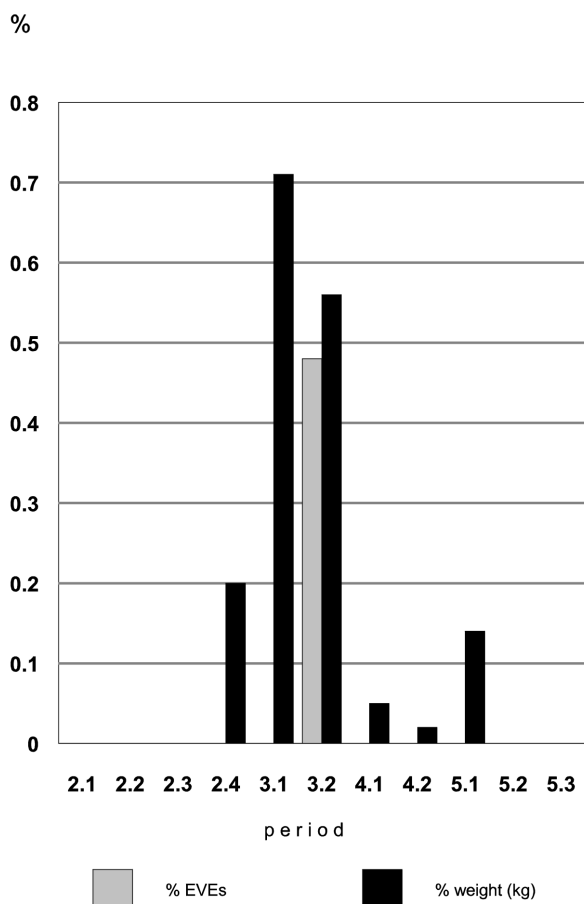

Fig 44 London-type ware: bar chart showing percentages in stratified contexts (ceramic periods).

### Scarborough ware (Fabric 24)

[Fig 45]

	Phase I (Fabric 24A)	Phase II (Fabric 24B)
Weight:	0.250 kg	0.020 kg
Number of sherds:	21	3
EVEs:	0.34	0

Scarborough, on the Yorkshire coast, was the centre of an

important pottery industry whose products were widely traded across Britain and the nearby Continent, including Scandinavia. Two fabrics, corresponding to two production phases, have been recognised: Phase I wares have a soft, friable, sandy pinkish-red fabric, dated to the period c 1135-1225; Phase II has a hard, smooth fabric ranging from pink and buff to white and dated to c 1225-1350. Vessels in both fabrics were normally covered in a good-quality green glaze. The popularity of Scarborough ware may be attributed to its production of highly decorated wares such as knight jugs and *aquamaniles* with finely modelled plastic decoration (Farmer 1979). In recent years, however, the dating of Scarborough ware has been called into question (Farmer *et al* 1982), particularly the early dating of highly decorated vessels. Although the excavators of the kilns vigorously defend the dates they have proposed for the Scarborough industry, they have pointed out that the appearance of the highly decorated wares did not occur until c 1200, a date which seems to mark the beginning of Scarborough as an export industry (*ibid*, 84). Although significant, these arguments and counter-arguments are complex and of little relevance to the situation in Colchester, where it seems likely that the small amounts of Scarborough ware present are almost entirely residual in their contexts.

A minimum of ten vessels has been identified on excavations covered by this volume: seven in the earlier Phase I fabric; three in Phase II fabric. A Phase I vessel from the 1986-7 Angel Yard site and a piece in the Colchester Museum brings the total number of Scarborough ware vessels from Colchester to twelve. For the most part these occur as small, abraded, isolated sherds, suggesting they are not contemporary in their contexts. The only two certain forms represented from the excavations are jugs (Fig 45.1-4; all Phase I) and a possible lid (Fig 45.5; Phase I). Figure 45.2 and 4 probably come from the same vessel. All of these have a deep green glaze, apart from the plain jug base (Fig 45.3) which is clear glazed. Decoration is represented by an incised rim (Fig 45.1), some grooved neck/shoulder sherds and a single Phase I sherd with narrow vertical applied strips in the pale Phase II fabric (COC L1). Highly decorated products are represented by a curved rod-like sherd which was clearly an applied feature (such as a human or animal limb) from a knight jug or an *aquamanile* (MID L537; not illustrated). To this may be added a second piece, almost certainly the trunk and mane of an applied horse from a knight jug (40:86 L194; not illustrated; Angel Yard). One other sherd appears to come from a tubular spout or similar element of square section with a circular bore (CPS L22; not illustrated).

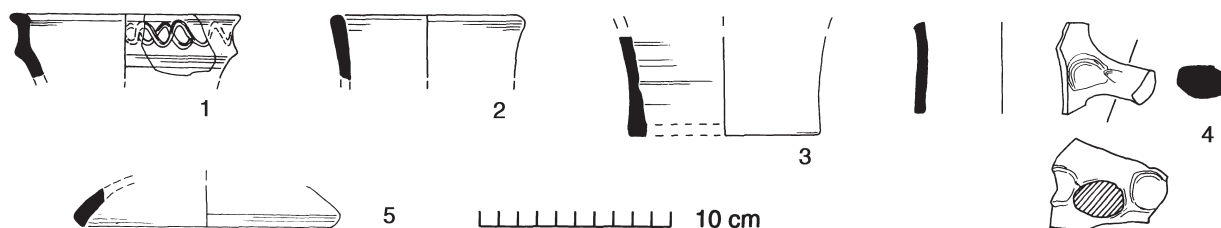

Fig 45 Scarborough ware: jug sherds (nos 1-4); ?lid (no 5). 1:4.



There is an unusual hollow and green glazed anthropomorphic figure in Colchester Museum from Queen Street (CM 588.1903; not illustrated), which also appears to be Scarborough Phase I. This is wheel-thrown, with pierced-through eyes and a featureless helmet-like head badly abraded in the facial area. The tops of the arm/shoulder stumps are deeply grooved like many Scarborough and Yorkshire jug handles. This unusual figure (surviving height 87 mm) might represent a knight seated on an *aquamanile* or possibly the knob of an elaborate lid.

Vessels in Phase II fabric include a horizontally grooved sherd and a thumbled jug base (not illustrated; base MID 707).

The significance of Scarborough ware in Essex and its influence on the north Essex fine-ware industry at Heddingham have been discussed at length elsewhere (Cunningham *et al* 1983). The Heddingham industry was largely contemporary with that of Scarborough, and certain Scarborough products, *aquamaniles* for example, were directly imitated by Heddingham potters (see pp 83 & 87-9).

#### Other Yorkshire wares (Fabric 24X)

[Fig 46]

Weight: 0.730 kg

Number of sherds: 16

EVEs: 1.14

This category includes vessels originally thought to be Scarborough ware but subsequently discounted by those more familiar with this industry (Peter & Nita Farmer, pers comm, 1987; Alan Vince, pers comm, 1987). It seems likely that the vessels in question are products of some lesser-known Yorkshire industries perhaps influenced by Scarborough ware. Only three vessels fall into this category. Figure 46.1, a tall baluster strip jug, has been identified as Beverley ware (c 1225-1350) from the town of that name near the Humber estuary (Gareth Watkins, pers comm, 1987). It has

a visually similar fabric to Scarborough Phase I but perhaps with the addition of some moderate white (calcareous?) inclusions. The applied strips occur in the same body clay and avoid the spout and handle area. Only a trace of the handle remains but enough to see that it was probably of rod section and secured to the body by impressed 'ears' on either side. The outside is covered by a deep green glaze which has pooled and thickened into a droplet on the rim, showing clearly that the vessel was fired upside-down. It came from a cess-pit (LWC BF5) which appears to have been contaminated with some modern sherds. However, the great bulk of associated pottery consists of local 13th-century wares including Heddingham ware.

Figure 46.2 is in an even, sandy, pale grey fabric with oxidised orange-pink surfaces covered externally with a patchy dark green copper-flecked glaze. Superficially the fabric resembles that of Scarborough Phase I. The stylised applied face mask has similarities with Grimston ware from Norfolk but it is not this fabric (Alan Vince, pers comm, 1987). One other sherd, part of a jug handle in a creamy-buff fabric covered with green glaze, has also been identified as a Yorkshire product, perhaps York glazed ware or Brandsby-type ware (Stratified Group 7, Fig 218.5, c 1225-75; John Hurst, pers comm).

#### Heddingham ware (Fabric 22)

[Figs 47-53]

Weight: 15.515 kg

Number of sherds: 938\*

EVEs: 7.2\*

Heddingham ware has long been recognised as the most distinctive medieval fine ware of northern Essex. Kilns at Sible Heddingham, and near Gosfield and Halstead, some fifteen miles (24 km) west of Colchester, have been excavated between 1958 and 1971 (Wilson & Hurst 1958, 211 & 1959, 325; Wilson & Hurst 1965, 215-17; Webster & Cherry 1972, 205 & 1973, 184 & 1974, 220).

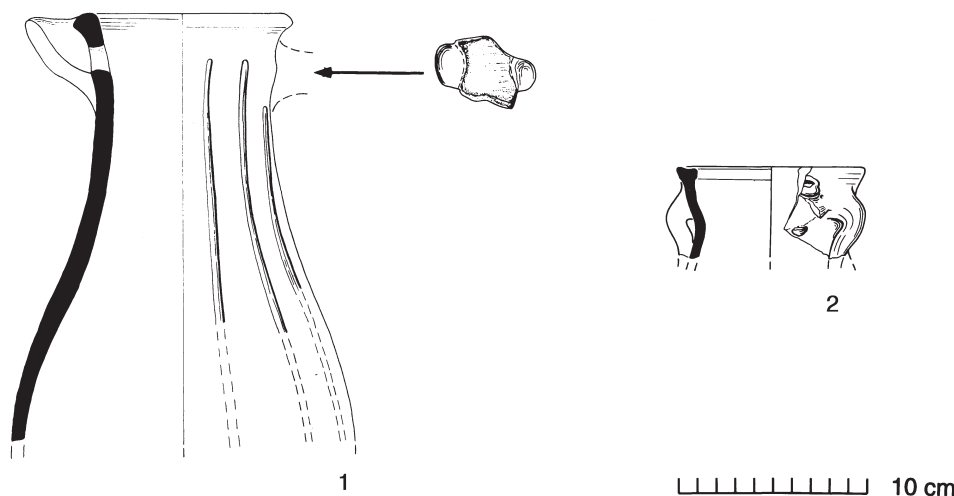

Fig 46 Other Yorkshire wares: Beverley ware strip jug (no 1); Yorkshire-type anthropomorphic jug (no 2). 1:4.

Remarkably little Hedingham ware has found its way into publication until now. Published groups containing more than a handful of sherds are limited to King John's Hunting Lodge, Writtle (Rahtz 1969); Naylinghurst, Braintree (Drury 1976a); Harwich (Walker 1990a); and an important assemblage from Denny Abbey, Cambridgeshire (Coppack 1980). A most useful assemblage from Rivenhall, written up by P J Drury in 1976-77 and extensively revised in 1983 by C M Cunningham, has now been published (Drury *et al* 1993). A report on an interesting group from Thetford in Norfolk remains in archive (Rogerson & Dallas 1984, 124-5). Other sites in Chelmsford have produced small but chronologically significant groups of Hedingham ware (Cunningham forthcoming), but the assemblage from Colchester, for the first time, provides a fairly detailed introduction to the ware.

**Fabric**

The characteristic fine ware is normally soft, smooth and fine, containing much very fine white mica. Thin-sectioning shows it also contains abundant fine quartz, sometimes with medium quartz sand, and small quantities of iron oxide, red clay pellets and altered glauconite. There are two distinct variants. The first is fine and smooth, often light buff or even off-white, and is mostly associated with early rounded jugs. The second tends to be orange or pink with a sandier, more open texture, and is mostly seen in the stamped strip jugs.

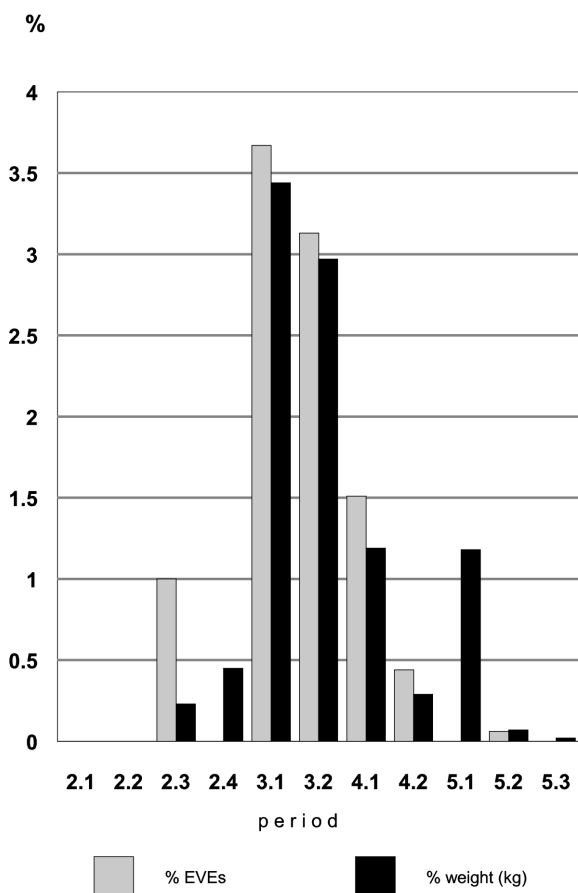

Fig 47 Hedingham ware: bar chart showing percentages in stratified contexts (ceramic periods).

In addition to this distinctive fine ware, there is visually similar but much coarser fabric. It is also light buff to orange in colour, but with very little mica and containing moderate quantities of fine to coarse quartz, giving a much harsher texture. There are also sparse quantities of flint, iron oxide, and white, red and buff clay pellets. This type was first recognised at Thetford, where its close resemblance to standard Hedingham fine ware suggested that it was a product of the same industry. However, it is not impossible that this type was produced somewhere in Suffolk in the early Hedingham-ware tradition, and its occasional occurrence in Colchester and northern Essex does not preclude this.

The main output of the Sible Hedingham kilns appears to have been coarse greywares: cooking pots, bowls, storage jars, pitchers and the like. No definite examples have been identified at Colchester, although some may be present among the Fabric 20 (see pp 101-4).

**Form and decoration**

[Pl 1 & Fig 48]

Owing to its fragmentary nature, the material from Colchester does not always provide the best examples known to exist in Hedingham fine ware, nor can it be claimed that the full range of forms and decoration is represented here. Nevertheless, the general picture here seems to be borne out by material in (largely unpublished) museum and site collections seen by Carol Cunningham and the author. The Colchester material must then be regarded as an introduction to Hedingham ware, and any attempt to set the study of this industry on a firmer typological footing must await full publication of the kiln material.

Jugs are virtually the only form present. These show a strong mixture of influences from both London-type and Scarborough ware which are sometimes difficult to disentangle in terms of one industry or the other, but ultimately this gives Hedingham ware its distinctive character.

Association of particular types of vessel form and decoration have suggested the groupings presented below, but a fair degree of overlap is apparent, with most types of decoration occurring on most forms of jugs. Exceptions to this seem to occur in both the early and late stages of the industry, ie in the earliest ('London-style') early rounded jugs and the much later pear-shaped jugs, where a more restricted range of decoration is employed. The smaller rounded jugs and the squat jugs (which are closely related 13th-century forms) exhibit more variety in their choice of decoration although one style, the stamped strip jug, tends to predominate.

1. *Early rounded jugs* (Fig 49.1-13)

This class is characterised by a full rounded ovoid body which tapers downwards to a slightly splayed sagging base, normally plain (Fig 49.1 & Pl 1 rear) but sometimes continuously thumbled (Fig 49.2). The neck is slightly flaring and on many examples typically ribbed or rilled. Rims may be collared (Fig 49.1) or sub-collared (Fig 49.3, 5), or thickened and flat-topped, somewhat triangular, or hammer-headed (Fig 49.2, 4, 6, 8, 12-13). In rare cases the rim is



Fig 48 Hedingham ware: jug sherds with high-relief plastic decoration including red pellets (sherd to far left from Witham, CM 151.56).

almost flanged (Fig 49.9). Wide sub-squared strap handles are associated with ribbed necks (Fig 49.1), while more crescent-section straps are associated with slacker early rounded forms or forms with thumbled bases (Fig 49.4, 12-13). Pouring-lips sometimes occur; these are usually quite superficial or incipient with a light finger indent on the inside of the rim and a pair of flanking indents on the outside (Fig 49.4, 6). Applied bridge spouts occur on a few jugs (Fig 49.7-8), and short tubular spouts are known from the kiln-site (*see below*).

The ribbed necks, collared rims and simple geometric designs and blobs in dark red clay are closer in appearance to London early rounded jugs and commonly occur in the fine off-white or light buff fabric either with a clear or a pale olive-green glaze. When thick and glossy, this glaze has something of the Saxo-Norman 'look' of Stamford-type ware and other early glazed wares. Some of these glazes were definitely coloured green by the addition of copper, which is standard on the later stamped strip jugs (*contra* Pearce *et al* 1985, 129).

#### Decoration

Other than its micaceous fabric, the most distinctive feature of Hedingham ware is its use of polychrome, achieved by painted and high-relief plastic decoration. On early rounded jugs, the neck is normally treated as a separate decorative zone from the body. Necks may be ribbed (Fig 49.1) or may have rows of applied pellets, either in contrasting dark red/brown clay (Fig 49.3) or in the body clay (Fig 49.5), which on this last example have been smeared on as crude scales.

On the body of the collared, pale-firing jugs and on some slacker jugs with plain necks, there is often a simple geometric frieze of X-shaped or lattice form in dark red slip (Fig 49.1) or a hybrid lattice/chevron frieze joining a

horizontal line at the neck (Fig 49.4). A large early rounded jug, from a kiln at Gosfield and now in Colchester Museum, has a line of dark red loops around the shoulder below which are attached fan-like groups of red strokes which in places branch and overlap with adjacent groups (Pl 1, rear).

The distinction between polychrome slip painting (which was probably applied in a semi-plastic state) and high-relief plastic or strip decoration is not always a clear one, although in general high-relief plastic decoration is normally carried out in body clay with minor details in red clay. Figure 49.2 has thick horizontal lines or bands of red and white slip on the neck and traces of a single vertical white strip to one side of the handle. The body decoration of this jug is unfortunately missing although the surviving neck decoration and the use of vertical white strips is on a smaller Rouen-style jug (Fig 50.15), so perhaps Figure 49.2 was also decorated in this style. The form too is somewhere between an early rounded jug and the Rouen-style baluster form.

High-relief plastic decoration occurs on early rounded jugs of larger or squatter form and on narrower or slacker forms. In both cases, this type of decoration is usually associated with applied bridge or tubular spouts and highly stylised anthropomorphic decoration (Pl 1). The larger squatter jugs (as Fig 49.1) with plastic decoration are not well-represented among the Colchester material, but probably occur none the less. These are best represented at the Hole Farm kilns, Hedingham by the 'Pig Jug', so-called after its snout-like short tubular spout attached below the rim (Walker 1986, fig 2). This possibly unique jug is decorated on the neck with horizontal rows of red pellets or pads (as Fig 49.3). On either side of the tubular spout, there are groups of stabbed impressions representing eyes and beneath the spout is an applied 'bib' or chin stabbed (like Fig 49.7) to resemble a beard. The body of the 'Pig Jug' has a decoration of running scrolls or tendrils in red clay (similar to Pearce *et al* 1985, fig 21.43), which have been stabbed,

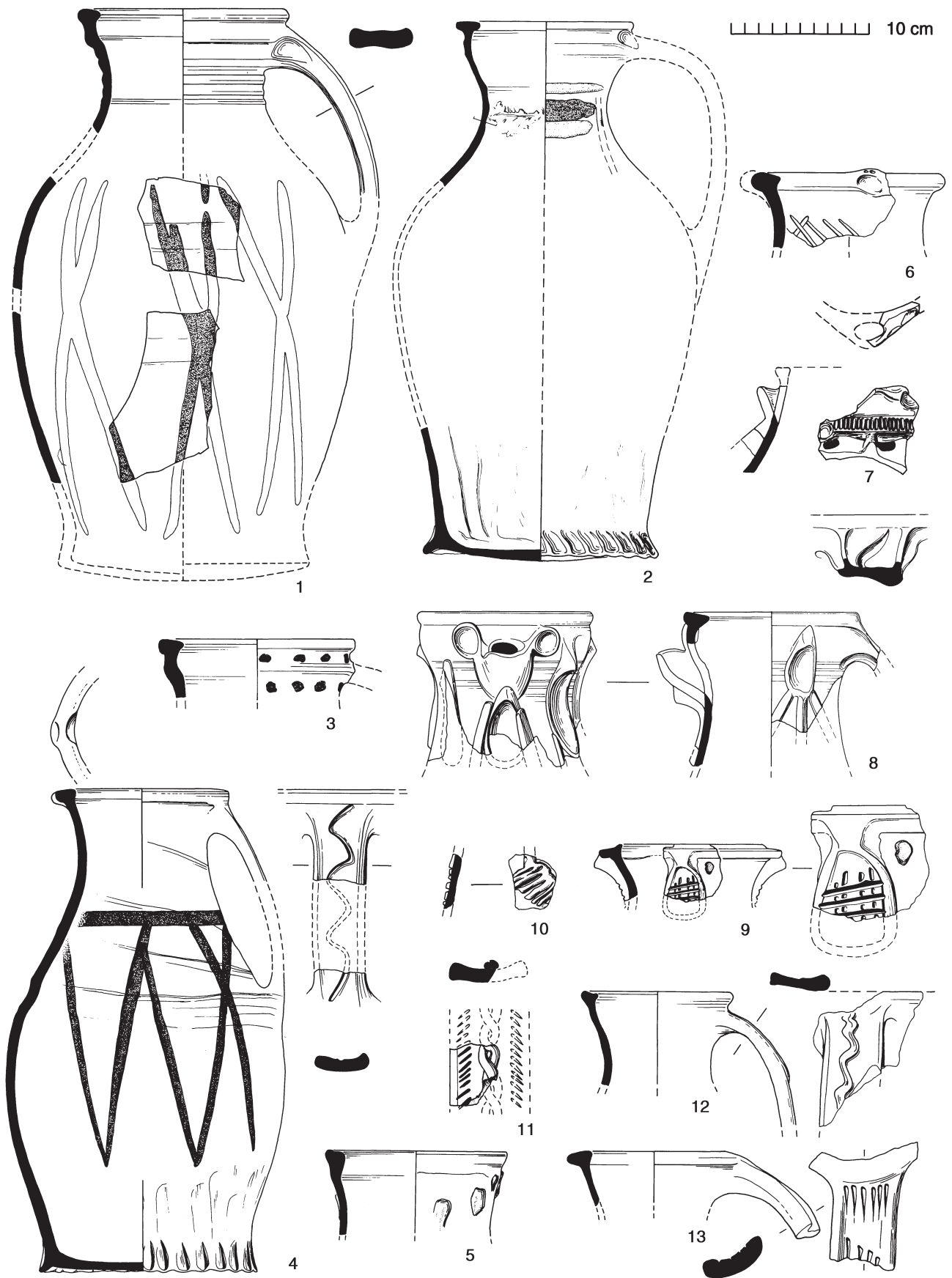

Fig 49 Hedingham ware: early rounded jugs with slip or high-relief plastic decoration (nos 1-13). 1:4; no 9 detail at 1:2.

and above the thumbled base there is a separate zig-zag frieze. A strap handle with an incised wavy line probably comes from the same vessel. The scroll decoration on this jug marks the first appearance in Essex of a design that persisted on Essex pottery into the 16th century.

A large early rounded jug sherd from Naylinghurst, Braintree is entirely covered with a complex arrangement of notched vertical strips in body clay which entwine at intervals in a twisted cable-like effect. A twisted strip also runs up the centre of the (broken) strap handle (as Fig 49.11), and some of the elliptical zones created by the strips are filled with red pellets (see Fig 52 for reconstruction). The overall effect is something like a fusion between Scarborough and Rouen-style decoration (Drury 1976a, fig 8.15; McCarthy & Brooks 1988, fig 180.1118). Similar but smaller fragments of this design are known from Colchester (not illustrated, LWC CF113 & CPS L44).

Most fragments from Colchester with high-relief plastic decoration appear to come from slacker early rounded jugs (Fig 49.5, 7-11). Probable anthropomorphic jugs are represented by Figure 49.7-10 but the 'face' is so highly stylised on jugs that in some cases it is uncertain whether the anthropomorphic effect was intended in the first place. The main anthropomorphic elements, probably representing ears and/or noses, are in body clay and are often associated with spouts. The eyes are sometimes suggested by the position of red pellets (Fig 49.7, 9) but, as on the 'Pig Jug' and Figure 49.3, the pellets are sometimes simply part of an overall polkadot pattern. On Figure 49.7, the pellets seem to represent eyes on either side of a fragmentary nose. Above these, under the spout, is a projecting cordon or fringe which may represent hair, or on other examples perhaps a beard. Applied pear-shaped pads, either plain (Fig 49.8) or with slashed decoration (Fig 49.9), are a characteristic feature of Hedingham early rounded jugs and are known from the kiln-sites at Sible Hedingham. On a sherd from Witham (Fig 48, left), the slashed pad clearly represents a stylised nose/mouth flanked by a pair of larger than usual eye-like red pellets with a central hole. As on Figure 49.8, three high-relief strips radiate downwards from the pear-shaped pad but, on the Witham sherd (as on the Naylinghurst sherd above), the strips have notched decoration possibly done with a bird bone. A bird bone or other serrated point was used for the stabbed decoration on Figure 49.11, the only strap handle from the excavations with a centrally applied twisted strip. Figure 49.10, a more shapeless slashed pad, could represent the terminal of a stylised limb, perhaps a hand. One example of a simple circular applied pad with vertical slashes occurs on the Angel Yard (1986-7) site. This was on the neck of a jug and may be a precursor of the applied circular stamps on later Hedingham jugs.

Incised wavy lines occur down the strap handles of both slip painted and plastic decorated early rounded jugs (Fig 49.4, 8, 12). Groups of stabbed or slashed ('cat's claw') decoration occur down the backs of one or two handles from Colchester (Fig 49.13), also on a handle from Pleshey Castle (Williams 1977, fig 31.16) and on a squat Hedingham jug from Whittlesford, Cambridgeshire (Rackham 1972, pl 88).

Incised decoration occurs on the bodies of a few early rounded jugs (Fig 49.6, pale fabric), and combed decoration might also occur on this form (Fig 51.25-26) but this is less certain. Both at Colchester (MID CL127) and Rivenhall,

there are rare sherds, probably from early rounded jugs, which have strips of dark red clay applied over a previously green glazed body. If intentional, such overglaze decoration would almost certainly require two firings; alternatively it could represent a kiln accident, perhaps the detachment of an applied strip from an adjacent vessel in the kiln.

## 2. Rouen-style jugs (Fig 50.14-16)

This type of jug, which originated in the Rouen area of north-west France (Barton 1965), is well demonstrated in London-type ware (Pearce *et al* 1985, figs 25-32). The evidence from Colchester is too fragmentary to be certain about the appearance of the vessels when complete. No flat or recessed bases (as at London) are present, so it must be assumed that these continued to have simple sagging or thumbled bases, and it is likely that the baluster form was a looser interpretation of its London-Rouen prototype. Figure 50.15, which is closest in spirit to Rouen designs, could be a baluster jug or alternatively it could be a smaller, more globular-bodied version of the smaller rounded jug which was the standard form for 13th-century stamped strip jugs (eg Fig 50.17). Unlike the latter, however, Figure 50.15 retains the stabbed strap handle of early rounded jugs. The similarity between the slacker early rounded jug Figure 49.2 and the decoration on Figure 50.15 has already been noted, and perhaps originally the missing body area of Figure 49.2 was decorated in the Rouen style. The tapering lower walls and splayed base of the latter also have something of the character of a baluster jug, the usual London-Rouen form, and the impressed 'ears' on either side of the (?strap-)handle are also matched on Figure 50.15.

The 'wasp' design of Figure 50.14 is probably derived from Rouen-style designs, although similar designs are found on London early rounded jugs (eg Fig 43.2). This is almost certainly a jug of smaller rounded form rather than baluster form. Exactly this design occurs on a small rounded Hedingham jug from Barrington, Cambridgeshire now in the Cambridge Museum of Archaeology and Anthropology (accession no 1947.610). The Barrington jug has a plain sagging base, a gently collared rim and incipient pouring-lip as Figure 50.17, and significantly it also has a twisted rod handle as on the stamped strip jugs (Fig 50.17 and 23). The plain rod handle on Figure 50.14 is the usual handle-type on London-Rouen jugs. This and the simpler rim form could indicate that it is slightly earlier in date than the Barrington jug. Hedingham Rouen-style jugs are thus significant in providing the link between early rounded jugs and stamped strip jugs.

## Decoration

As with London-type ware, the classic Rouen-style effect is achieved by the use of thin red-painted zones delineated by thicker squeezed white strips and pellets. Unlike some later Rouen copies in London-type ware (*ibid*, 28), the Hedingham decoration is always carried out against the natural orange background of the body clay and not against an over all application of white slip. Designs are always accompanied by a thin clear glaze sometimes tinged light green. Classic Rouen-style is limited to the vertically-striped or ladder-like design (Fig 50.15; cf *ibid*, fig 30.78, 80 & fig 32.94), and possibly the oval, crudely shield-shaped design (Fig 50.16; cf *ibid*, fig 29.73).

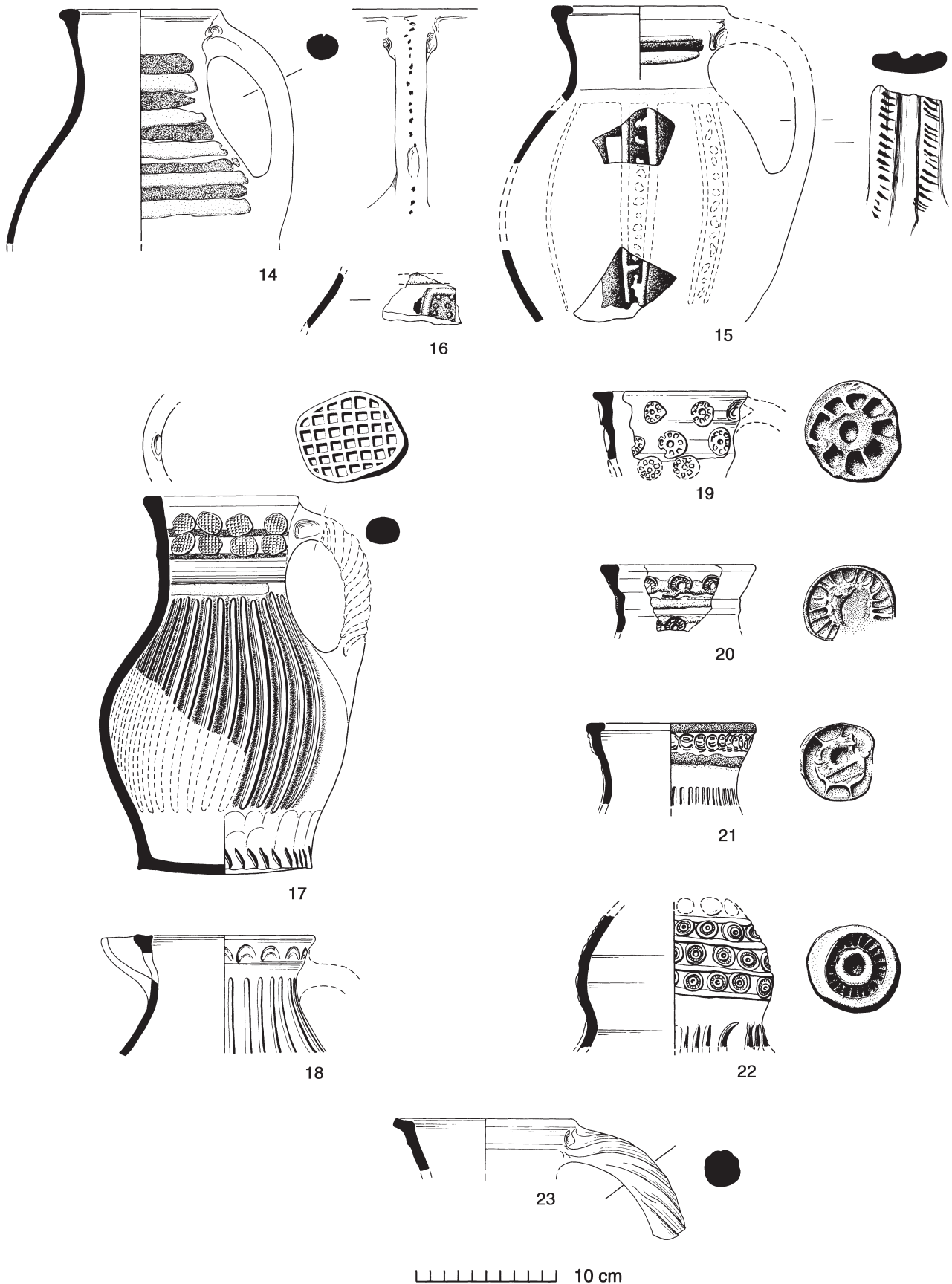

Fig 50 Hedingham ware: Rouen-style jugs (nos 14-16); stamped strip jugs (nos 17-23). 1:4; stamp details at 1:1.

'Wasp' designs of alternating horizontal red and white strips, as on Figure 50.14 and the Barrington jug, are not exactly matched in the London Rouen-style type series which generally prefers more complex decorative schemes. However, the general idea of alternating red and white zones of slip decoration is so fundamental to the Rouen style that there can be little doubt that this was the inspiration behind the Hedingham 'wasp' design. The design is very closely approached on a few London Rouen-style jugs (eg *ibid*, fig 31.86-7), but never gets quite as simple.

### 3. Stamped strip jugs (Fig 50.17-23)

These are mostly rounded jugs, very similar in form to the early rounded jugs but smaller and now provided with a rod handle, usually twisted. Vessels are often thick-walled and occur in the sandier orange-pink fabric commonly beneath a dark mottled green glaze. Rims are simple, thickened and flat-topped or somewhat triangular, sometimes with a hint of a collar below this. Figure 50.20 is typical of the majority of jug rims. Bases are either plain and sagging or continuously thumbbed, sometimes as a sequence of deep nicks made with the thumb-nail (Fig 50.17). Incipient pouring-lips occur on a few examples (Fig 50.17), and bridge spouts too are not unknown (Fig 50.18).

#### Decoration

The neck, and rarely the whole body, is decorated with rows of stamps. Three main types of stamp occur at Colchester: gridiron or pastille (Fig 50.17), horseshoe or crescent (Fig 50.18), and a variety of cartwheel stamps (Fig 50.19-22). Simpler ring-and-dot stamps are known elsewhere (Rahtz 1969, fig 52.15, 15A; Drury *et al* 1993, fig 43.128, 130-2). Their method of application varies, however. Sometimes these are in the form of applied pads (Fig 50.17, 19, 22), sometimes they appear to be impressed into a ribbon of dark red clay applied to the neck (Fig 50.20), and in some cases the surplus ribbon clay around the stamp has been peeled off leaving the stamps to contrast with the lighter body clay (Fig 50.21). Others are stamped directly into the body clay (Fig 50.18).

Figure 50.17 is typical of the decorative scheme seen, with minor variations, on the majority of Hedingham stamped strip jugs. The two ridges on the neck have been highlighted with dark red horizontal stripes or applied ribbons, and the same dark red slip covers the entire body of the jug except for the base and handle areas. Twenty circular gridiron stamps in a paler body clay have been applied around the neck, partly overlapping the red stripes and partly the natural body clay. Below this, the neck is finely grooved or rilled horizontally, and below this is a broad applied ribbon of pale-firing body clay the same colour as the stamps. On the body of the jug proper, vertical-oblique strips of pale-firing body clay have been applied over the red-slipped area to create a contrast. Due perhaps to firing conditions, the colour contrast on this particular jug is not as marked as was probably intended. It is not impossible, furthermore, that the red body slip was applied after the application of the vertical strips. The bleeding of colours in the kiln has blurred this distinction, but the 'slip before strips' technique appears more likely. A mottled green glaze covers the outside of the vessel, ending 60 mm above the base.

All the stamped strip jugs from Colchester normally occur with both stamps and strips in natural body clay or a slightly

paler body clay. Stamps are only red when, as described above, they are stamped into a red clay ribbon or broad strip. Applied vertical strips in darker red clay are less common, but some of these (present as smaller sherds) probably come from jugs of this class. There are also a few sherds from the excavations with vertical strips in white clay on a red-slipped background. Some of these could be from Rouen-style jugs, but the closely-set strips must come from stamped strip jugs. Confirmation of this colour scheme is provided by sherds of a Hedingham jug from Feering, Essex (CM 165.1976) and a complete unprovenanced Hedingham jug in the Cambridge Museum of Archaeology and Anthropology (Z.20737). Both of these have applied cartwheel stamps and vertical strips in white clay on a red-slipped background.

Perhaps the most unusual Hedingham shape from the Colchester excavations is Figure 50.22. The body is waisted or gourd-shaped with at least four rows of cartwheel stamps and intervening horizontal strips in the bulbous upper(?) part of the vessel, and, possibly, groups of vertical strips in the wider lower part. It may come from a waisted pear-shaped jug such as those occurring in the North French or highly decorated style in both the London-type and Kingston-type industries (Pearce *et al* 1985, fig 53.191-3; Pearce & Vince 1988, fig 68.95-6, fig 69.97-9), or it could even be from a waisted puzzle jug such as occur in Oxford ware (Hinton 1973, pl 12; McCarthy & Brooks 1988, fig 170).

Figure 50.19 is the only example from the excavations with more than two rows of applied stamps on the neck. This example, which is over-fired and in a slightly coarser fabric, could be a mis-identified jug in London-type ware but the stamps are not closely paralleled at London (Alan Vince, pers comm, 1987). Hedingham jugs with up to four rows of neck stamps are, however, known from Rivenhall (Drury *et al* 1993, fig 43.128 & 130).

### 4. Squat jugs (none illustrated)

These have not been recognised from the excavations but probably exist in sherd form. Two complete Hedingham jugs from Cambridgeshire, one from Whittlesford and one from Horningsea, provide the type-examples for this form (Rackham 1972, pls 88 and 33 respectively). The form is a wider, squatter version of the early rounded jug form (eg Fig 49.1) or perhaps more accurately a wider version of the smaller rounded jug (eg Fig 50.17), which it resembles more closely in terms of height and decorative treatment. Squat jugs are fractionally taller than they are wide at the maximum girth (eg Whittlesford = approx 274 x 245 mm; Horningsea = 275 x 260). Squatter early rounded jugs might loosely be included in this category but the height of the only measurable profile, the so-called 'Pig Jug' from Sible Hedingham (*see above*), is significantly greater than its width (approx 340 x 246 mm) and more like the height of other early rounded jugs.

The affinities of the two Cambridgeshire jugs seem fairly clearly to lie with the Rouen-style and stamped strip jug phases of the industry. The Whittlesford jug (*ibid*, pl 88) has the fine sandy orange-grey fabric of the strip jugs. The neck is decorated Rouen-style as Figure 50.15 with broader horizontal bands of red and white slip, while the upper half of the body is covered with red slip on which broad strips of white clay have been applied. Two zones of decoration are

defined by three horizontal bands; in the upper zone there are sets of up to five vertical strips while the lower zone contains a frieze of concentric arches. The Whittlesford jug has a strap handle with slashed 'cat's claw' decoration as on Figure 49.13, and the base is plain and sagging. A patchy pale green glaze covers the front and middle area of the jug. A sherd with very similar decoration to that of the Whittlesford jug, also with a red slip background, has recently been published from Harwich (Walker 1990a, fig 15.32).

The jug from Horningsea (Rackham 1972, pl 33) is a standard stamped strip jug with ring-and-dot stamps on the neck and vertical strips in body clay overlying a red-slipped body. The handle is of standard twisted rod type.

Interestingly, both the Cambridgeshire jugs have been repaired below the handle with lead rivets, a measure of how much they were valued by their owners.

#### 5. Pear-shaped or biconical jugs (Fig 51.24)

These tend to have a more flanged rim, and are also somewhat collared, with a narrower, more elongated body shape. Handles tend to have a squared section with vertical grooving. The fabric is intermediate, neither particularly fine nor particularly sandy. Decoration, where present, consists of vertical and diagonal combing or fine horizontal reeding, and the base is continuously thumbed. A complete example from Rivenhall shows the pear-shape to better effect (Drury *et al* 1993, fig 43.137) and a good example of a reeded Hedingham jug is known from Cambridge (Rackham 1972, pl 41). A complete but unprovenanced pear-shaped jug in the Museum of London is probably also a Hedingham product. This has the usual characteristics but with the addition of an applied bridge-like spout. The neck and body are decorated with notched vertical strips (*ibid*, pl 73). The combed jugs are normally covered with a green mottled glaze while the reeded jugs may be green or clear glazed.

#### 6. Miscellaneous jugs (Fig 51.25-27)

The precise form of these fragments is unknown. Figure 51.25-26 are decorated with combed decoration (six- and four-pronged respectively). This could suggest they come from pear-shaped jugs (see above), but other characteristics could indicate an earlier date thus suggesting the early rounded or smaller rounded jug form. Figure 51.25, which is green glazed, appears to be hand-made and the combed lattice design suggests an early-to-mid 13th-century date based on parallels in early medieval sandy ware (Fabric 13; Fig 34.29-31) and London-type ware (Pearce *et al* 1985, fig 34.108), though this style could have survived later. Figure 51.26 has a coarse off-white fabric with a pale grey core, and is covered with a pitted pale olive glaze. These characteristics are more associated with the early rounded jugs.

A base sherd (Fig 51.27) has paired groups of thumbing. There are specks of copper-green glaze externally and a large splash on the underside. This vessel was clearly used for cooking as it is heavily sooted on the underside and has a thick white deposit all over the inside. It could, possibly, come from a pipkin or small cooking pot rather than a jug; but as it occurs in the sandier fabric of strip jugs, and as no Hedingham jar rims have been identified from the excavations, it is probably best ascribed to a jug.

Tubular-spouted jugs are known from two examples at Rivenhall (Drury *et al* 1993, fig 43.123-4), but it is not known whether these belong to early rounded or strip jugs.

#### Construction

Constructional techniques are most clearly observed on the early rounded jugs, but many of them probably apply generally. There are two characteristic zones of particular roughness on the inside of Hedingham ware jugs: just above the base, and at the junction of the body and the neck

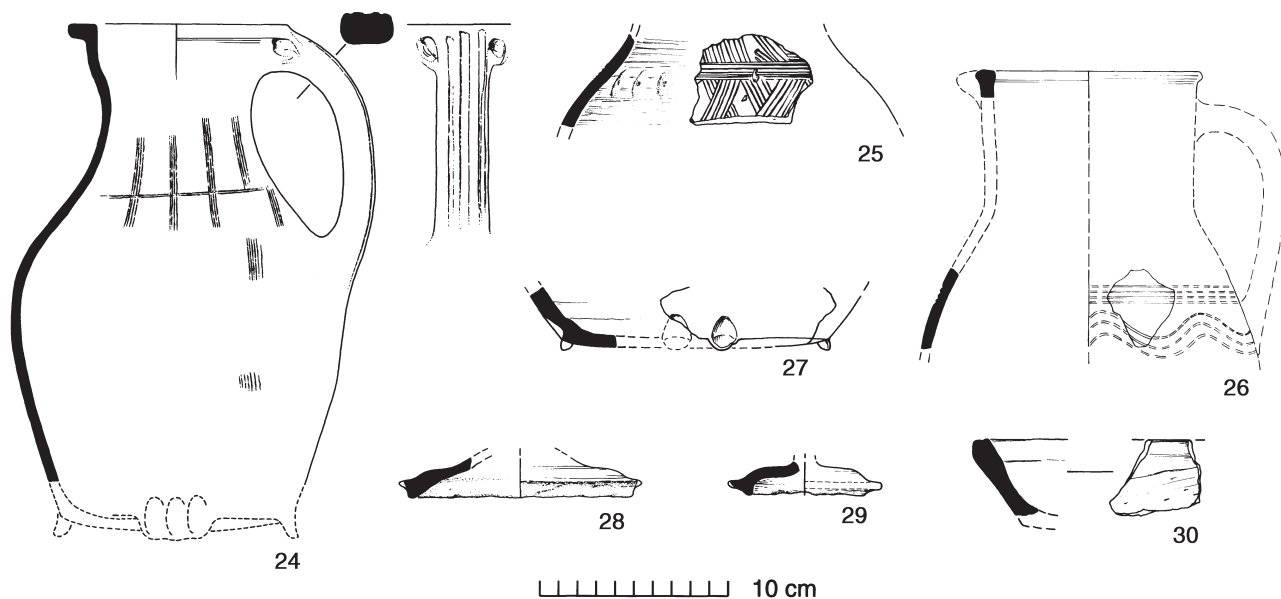

Fig 51 Hedingham ware: pear-shaped jug with combed decoration (no 24); jug sherds with combed decoration (nos 25-26); thumbing jug base (no 27); lids (nos 28-29); dripping pan (no 30). 1:4.



(Fig 49.2, 4 & Fig 51.25). This, together with the diverse direction of smoothing lines on the inside, indicates that the jugs have been made in sections and assembled by hand. On the whole, the neck sections are obviously wheel-turned. It is often less certain whether the bodies are wheel-turned or hand-built, but there seem to be examples of both. The bases appear to be mostly hand-made, presumably moulded. Most bases have been knife-trimmed externally while in the leather-hard state. Frequently the series of regular vertical knife-marks produce a faceted effect (Fig 49.4 & Fig 50.17).

The need for this method of construction may have been determined by the particularly fine, relatively untempered fabric which, when wet, may have lacked the innate strength to support an entirely wheel-thrown jug. It would be much easier to achieve large thin-walled vessels by assembling leather-hard prefabricated sections.

On stamped jugs, there is usually less evidence for composite construction and some of them could be completely wheel-turned, likewise the pear-shaped jugs. Where there is clear evidence, the handles of stamped strip jugs have been plugged through a hole in the vessel wall and then smoothed over. In some cases, a thin ribbon of clay appears to have been smoothed over the external wall/handle junction to give extra security. It is less clear whether the strap handles of early rounded jugs have been attached in the same way, and some appear to have been simply luted on to the neck and body. Most Hedingham jugs have impressed 'ears' on either side of the handle/neck junction. These would have assisted in securing the handle, although they were in part decorative. Occasionally the clay used in the handle has been visibly tempered, in contrast to the rest of the vessel, to give extra strength to a weak part of the vessel, and to help it fire. This is not as marked as many of the later Mill Green jugs (Pearce *et al* 1982, 289). The 'twisted' handles are produced by scoring lines into an ordinary rod handle. Only one handle, slightly coarser than usual and unglazed, has a true twisted or braided handle, but this is not definitely a Hedingham product (Stratified Group 11, Fig 225.4).

The majority of Hedingham jugs appear to have been fired upside-down. Glaze is largely confined to the body of the vessel. The rim, handle area and base are nearly always glaze-free and also sometimes the neck area. Glaze splashes on the underside of the base and under the handle/neck junction are fairly common and indicate the inverted firing position. The pitted quality of the glaze suggests it was dusted on. Sometimes there are raw globules of lead stuck to the surface. It is clear that all over application of red slip to the body was followed by vertical knife-trimming of the lower walls of the base as the slip often has been shaved away at its lower limit. In one or two examples, however, it can be seen that the plastic decoration was applied after the knife-trimming. On some of the stamped strip jugs, the glazed and slipped areas are remarkably contiguous, particularly at the lower limits where the glaze may end in a smooth line a centimetre or so below the slip limit.

## Other forms

[Fig 51.28-30]

Forms other than jugs are rare at Colchester. A Hedingham ram *aquamanile* with scale decoration (Pl 1, left) has already been published (Cunningham *et al* 1983, pl 2a & fig 3). A fragment, possibly from the filler-hole of an *aquamanile* or the top of a particularly coarse costrel, has been found on excavations on the Cups Hotel site in Colchester (not illustrated; CPS F3, residual). This occurs in a hard sandy orange fabric with all over external greenish glaze, and is in the form of a crude thick-walled cylinder widening towards the bottom, with a roughly pinched rim and a thick applied pad of body clay on the side.

An unexpected form from the excavation is the rim of a dripping pan (Fig 51.30). There is knife-trimming on the outer surface and a patchy green pitted glaze on the inside. The inside is also heavily sooted.

Two lids (Fig 51.28-29), from the same site (LWC C), occur in an unusually coarse pink/buff fabric with a pale grey core and a crazed and pitted yellow glaze on the outside. Both are abraded, but clearly were flanged. They may have been intended to sit on top of jugs. Figure 51.29 came from a typical early medieval robber-trench assemblage and is thus unlikely to be later than the 12th century (Period 3.1, 1150/1200-1250/75).

At Rivenhall a possible Hedingham chafing dish has been found (Drury *et al* 1993, fig 44.150), also a costrel, a possible cup (handle) and two pipkins (*ibid*, fig 44.151-4). An unprovenanced cylindrical costrel in the Saffron Walden Museum (Dunning 1964, fig 48.4) is now thought to be a Hedingham product (Drury *et al* 1993, 89).

## Discussion and dating

### 1. Hedingham ware from Essex and elsewhere

Hedingham ware is well known in Essex in contexts of the 13th century. In Chelmsford it is present in the earliest occupation of the new town *c* 1200 (Carol Cunningham, pers comm) and at Writtle it occurs in the earliest levels following 1211 (Rahtz 1969, 94). Dating evidence from the kiln-sites is not yet available, and the absence of Hedingham ware from London's waterfronts denies it the close dating which other regional wares have acquired by their presence there. But perhaps the most important dating evidence for both the early and late phases of this industry comes not from Essex, but from Cambridgeshire where small but highly significant assemblages have been published from Denny Abbey (Coppack 1980) and Waterbeach Abbey (Hurst 1966).

At Denny, Hedingham early rounded jugs first appear in deposits associated with the Benedictine occupation of the abbey 1159-1170 (Coppack 1980, fig 30.10-11). Unfortunately there are no 13th-century groups published from Denny, but Hedingham ware is again present as stamped strip jugs and probably as combed pear-shaped jugs in groups D and E dated *c* 1300-25 and *c* 1327-42 respectively (*ibid*, fig 31.23-9 & fig 32.40-45). A much smaller collection comes from Waterbeach Abbey occupied between 1293 and 1359, until the nuns were removed to Denny only two or three miles further north (Cra'ster 1966).

Significantly, only combed pear-shaped jugs were found at Waterbeach (Hurst 1966, fig 10.17, fig 11.18-20).

These Cambridgeshire groups therefore provide both the earliest and latest historical dating for Hedingham ware yet available. The 12th-century starting date for Hedingham ware at Denny Abbey finds further confirmation at Colchester where archaeological evidence suggests the ware was current by *c* 1140 (*see* below). The Cambridgeshire dates act as a corrective for the picture from Essex where there is little firm evidence for the end-date of the Hedingham industry and where a demise in the late 13th century would otherwise have been proposed, admittedly on slender evidence. In Essex, only the material from Rivenhall provides any indication that Hedingham ware was in circulation as late as the early 14th century, and this evidence is mainly based on the presence of late-looking forms such as a costrel, a chafing dish, a pipkin, and a ?cup represented only by a handle (Drury *et al* 1993, 89).

Most of the Hedingham ware at Rivenhall occurs in period 6B which covers the later 13th and much of the 14th century, but clearly much of this could be residual material of the early to mid 13th century. However, a nearly complete pear-shaped jug from period 6B (*ibid*, fig 43.137) is less easily dismissed as residual and in all probability this, and some sherds with combed decoration, are probably contemporary in their context and thus accord with the late dating of this type evidenced at Cambridgeshire sites.

It is easy to question the uncritical way in which the dated groups at Denny Abbey are presented, but this could be due in part to the general scarcity of information on medieval Cambridgeshire pottery, which makes factors such as residuality difficult to assess. On the basis of Essex parallels, it certainly appears that some element of the two 14th-century groups (D and E) at Denny is residual and this must include some of the Hedingham ware. The apparent absence of 13th-century groups is also puzzling. Denny group E, which dates to the renovations of *c* 1327-42, may indeed have been deposited between these years, but several cooking pot rims there would not be out of place in early-mid 13th-century Essex groups, and in all probability they represent residual 13th-century material. That some cooking pots and imports (?Saintonge) date from *c* 1250+ is, however, obvious, and some of these could be 14th century. Group D, however, which is dated to the first quarter of the 14th century, is not so closely dated by its historical associations. It is described as a 'late Templar deposit' from the north range of the Abbey (Coppack 1980, 228) and is sealed by the renovation deposits of *c* 1327-42. Templar occupation at Denny occurred between 1170 and 1308, but the exact construction date of the Templar north range is not known and could in theory have occurred at any time between these years (Christie & Coad 1980, 167, 173-4). There does not appear to be any firm evidence that group D at Denny is necessarily a late Templar deposit except for the fact that it derives from a midden deposit against the wall of the Templar north range and thus is stratigraphically later than it. The historical date bracket for group D, therefore, is actually *c* 1170-1327/42. This group contains a high proportion of Hedingham stamped strip jugs (Coppack 1980, fig 31.25-27, 29) which are known from many early-mid 13th-century contexts in Essex (eg Writtle, shortly after 1211), but the presence of a combed ?pear-shaped jug (*ibid*, fig 31.23) and a neckless local cooking pot (*ibid*, fig 31.22) point to a date after *c* 1250-1300 and perhaps earlier in this date-range. This not only appears to fit

all the evidence, but has the benefit of providing the Denny Abbey sequence with a 13th-century group which up till now has been curiously lacking.

At Waterbeach Abbey, too, there are grounds for caution. The limited trench excavation here produced only a small collection of pottery mostly from robber trenches and other disturbed levels. While no pottery types later than the 14th century were found, a handful of probably 12th-century sherds shows that at least some of the pottery from the site is earlier than the 1293-1359 occupation and must be residual in these levels (Hurst 1966, 89).

It is easy to be critical of the integrity of the assemblages on these Cambridgeshire sites, but problems of residuality are by no means confined to that county. However, better dating evidence than that from Denny and Waterbeach is not available, and in outline and many details the evidence seems sound and complements that emerging from Essex. Between them, Denny and Waterbeach demonstrate the main developments in Hedingham jug forms, from early rounded jugs in the 12th century (Denny group A) to the dominance of stamped strip jugs in the 13th century (Denny group D) and their replacement by combed pear-shaped jugs in the late 13th and the first half of the 14th century, as evidenced at Waterbeach where only jugs of this type were found (Hurst 1966, 92-3).

Combined with the dating evidence from Essex, the currency of Hedingham ware can now be placed between *c* 1140 and *c* 1350, although this last could arguably be reduced to *c* 1325 if residuality is borne in mind (Fig 52).

## 2. Dating evidence from Colchester

At Colchester we find some valuable dating evidence for Hedingham ware, especially for its early phases. Hedingham ware is first encountered in a complex of robber trenches sealed by a 12th-century stone building on the corner of Lion Walk and Culver Street (*see* p 5). Coin evidence from the site and architectural details suggest a date of *c* 1150 for the stone building. Hedingham ware is absent from the earliest robber trenches here (LWC GF233, GF203), which produced a coin of William I, lost *c* 1095, and a coin of Henry I, lost *c* 1115, but it is present in successive robber trenches (LWC GF73, GF220) cut by the foundation trenches of the stone building. Thus we have a date range of *c* 1115-1150 for the introduction of Hedingham ware at Colchester, probably towards the end of that range. This compares closely with the introduction of early rounded jugs at London by *c* 1140 (*see* below). A host of other contexts where Hedingham ware is associated only with early medieval sandy ware (Fabric 13), sometimes with the addition of (slightly residual?) Stamford, St Neots and Thetford-type wares, reinforces the picture of its currency by the middle of the 12th century and, by the late 12th and early 13th centuries, it is common in the town.

Only five sherds, however, can be attributed to contexts of Period 2.3 (*c* 1125-1150), but among these is a sherd from an early rounded jug with a painted red lattice (Fig 214.1, Stratified Group 5). A sherd with an applied strip and clear glaze is present in Period 2.4 (*c* 1150-1200), and in Period 3.1 (*c* 1150/1200-1250/75) both plastic decoration and stamped strip jugs are common.

The proportion that Hedingham ware forms of the ceramic assemblage in each period is shown in Figure 47. At its

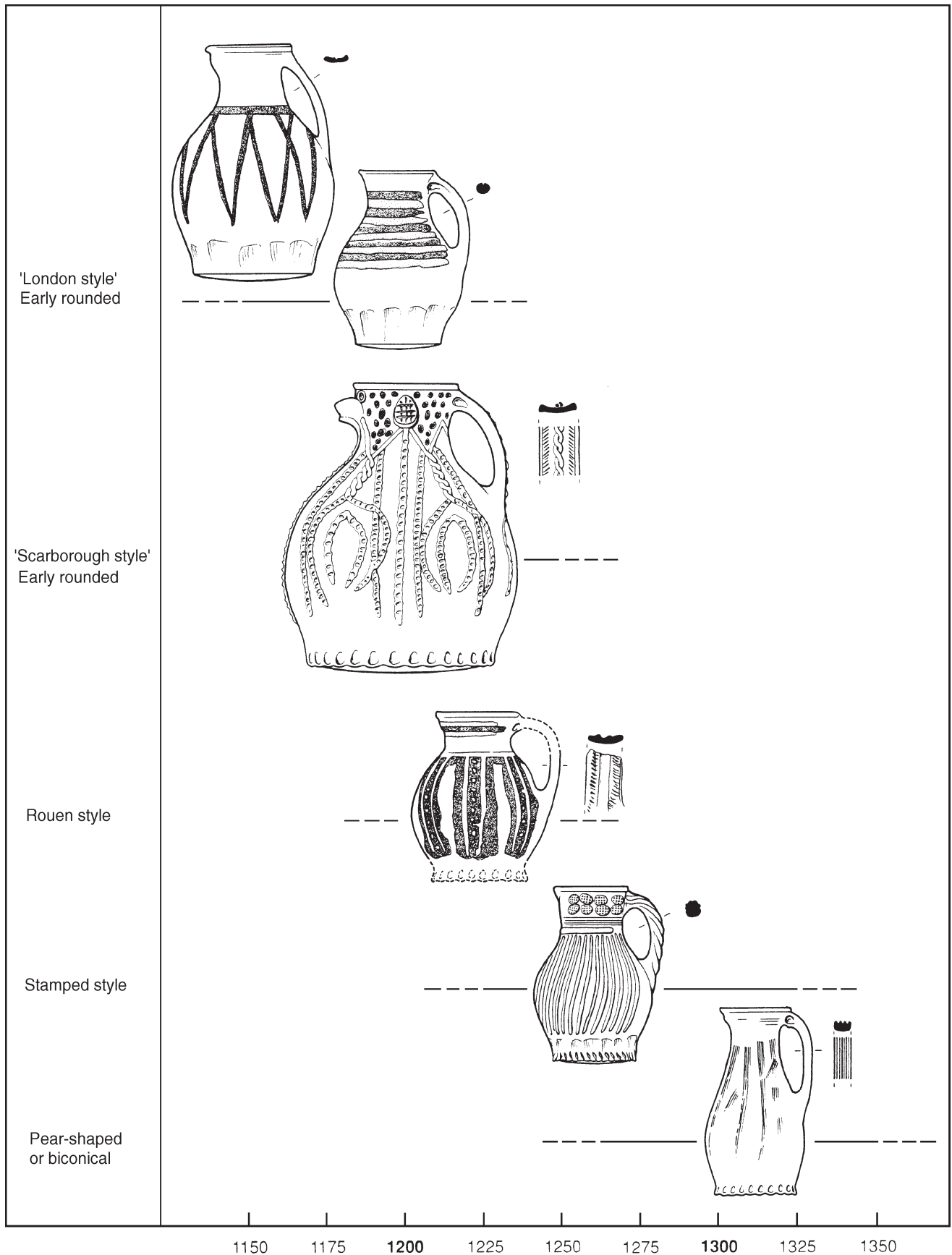

Fig 52 Diagram to show the estimated time-span of the main Heddingham fine ware jug forms.

peak in Colchester during Period 3.1 (1150/1200-1250/75), it formed 3.7% of the assemblage. In the smaller, more broadly dated Period 3/4.1 assemblage (mainly the Cups Hotel site), the fabric formed 7.1%, thus suggesting that a figure of around 5-6% could be a more realistic estimate of its peak circulation in the town. Of all Hedingham ware from the excavations, 2.2% occurs in Period 2.3 (c 1125-1150), rising dramatically to 44% in Period 3.1 and declining exponentially in each successive period. In Period 4.1 (1350/1400-1500), where 11% of the ware occurred, it was almost certainly residual.

Firm evidence for the end of the Hedingham industry is not available from Colchester owing to the lack of document or coin-dated contexts. The level of residuality also makes it difficult to chart the demise of Hedingham ware with any accuracy, just as it clouds an accurate perception of the changeover of forms. Nevertheless, the main sequence of developments in Hedingham ware can be charted here.

The early rounded jugs are the first to appear. There is very little information from Colchester on the earliest examples since these are present as small fragments. It seems likely that most of the 12th-century jugs had a simple lattice decoration of red slip under a clear glaze (eg Fig 214.1, Stratified Group 5, c 1125-50; Fig 49.1, Stratified Group 6, c 1175-1200). But already some vessels had a green copper-flecked glaze.

The use of applied pellets, scales, high-relief plastic decoration and stylised face masks (Fig 49.7-11) is something that seems to have come into use in the late 12th and early 13th centuries. These still occurred on the early rounded form of jug, but possibly the neck was no longer ribbed and the rim was less heavily collared than previously. In Colchester, this type of decorated jug is closely associated with, or immediately post-dates, the Fabric 13 kilns and ?potter's workshop at Middleborough for which a date of c 1175-1225 has been suggested (see p 67). Jugs with slashed or incised (rather than lightly combed) decoration, and perhaps also stabbed decoration, probably belong to this phase as well (Fig 49.6, 9-11).

Rouen-style Hedingham jugs, of whatever form, are not very common at Colchester and not very closely dated. Figure 50.15 with its more 'classic' Rouen-style design was associated with 12th- to 13th-century local wares, and extremely little material from this site (1.81 G) was later than c 1250. Figure 50.14 and 16 were residual or from contaminated contexts. If, as seems possible, the early rounded jug Figure 49.2 was originally decorated in the Rouen style, then this would be significant as it comes from a context of c 1225-75 (and probably pre-1250), where it was associated with a London-type ware jug also decorated in the Rouen style (Stratified Group 7, Fig 218.1). Together with the Rouen-style parallels from Barrington and Whittlesford, Cambridgeshire discussed above and the evidence from Essex, Hedingham Rouen-style jugs can be assigned to an intermediate position between the early rounded and the (smaller rounded) stamped strip jugs, thus representing a style of decoration overlapping in date with these other two styles or forms. This is likely to have occurred during the currency of the Rouen-style on London-type ware jugs c 1200-50, or perhaps slightly later.

Stamped strip jugs, almost all green glazed, are present throughout most of the 13th century. Figure 50.19 and 22 came from the same robber trench but represent two vessels. The same robber trench (LWC BF18) also produced

the rim of a North French green-glazed jug (Fig 174.6) and a Paffrath-type ladle (Fig 186.1), which places the date of this group in the first half of the 13th century if not the first quarter. Figure 50.20 from the Lion Walk ditch sequence (Stratified Group 4) is dated by its context to c 1225-1300. Hedingham stamped strip jugs probably overlap in date with Mill Green ware (c 1270-1350). Figure 50.23 occurred in the same context as a Mill Green rounded jug (Fig 121.4; Period 3.2, c 1250/75-1400).

Pear-shaped or biconical jugs are rarely complete enough to identify, but their association with oblique or vertical combed decoration or with fine horizontal reeding seems fairly well established and allows them to be identified from body sherds. The most complete example (Fig 51.24) comes from a Period 3.1 context (1150/1200-1250/75) but probably dates towards the end of this period. Aside from this, most sherds with combed decoration date to later periods. Many of these occur as single sherds which are probably residual, but a group of three combed sherds occurred with a Hedingham dripping pan (Fig 51.30) in a Period 3.2 context (c 1250/75-1400) which also produced sherds of a Mill Green combed jug (CPS L44). Another context on the same site (CPS L22) produced a group of five Hedingham sherds with combed decoration, together with several combed sherds of Mill Green ware and an almost complete Mill Green squat jug (Fig 121.3; Period 3/4.1, c 1200-1500). The concurrency of Hedingham and Mill Green ware during the later 13th and early 14th century thus seems reasonably well established.

### 3. Origins and affinities of the Hedingham-ware industry

The origins of the Hedingham-ware industry are obscure and a more detailed consideration of this must await the full publication of the kiln material. Some influence from the late Saxon wheel-thrown industries of East Anglia seems possible, particularly from the Thetford and Stamford-type industries. The reduced sandy fabric of Hedingham coarse-ware, and the presence of plain cooking pots with characteristic girth grooves and spouted pitchers and large storage jars with lattice strip decoration, are all features which could logically have descended from Thetford-type ware. Certainly Hedingham potters and those of the late Thetford-type industries at Thetford and Ipswich were probably familiar with each other's products, as Hedingham ware is reported both from Thetford and Ipswich (see below), while Thetford-type ware was common enough in north Essex. Against this, though, is the fact that Hedingham ware, like other Essex wares, was not a wholly wheel-thrown ware until the 13th century (see Fabric 20 account, p 106), and also that Thetford-type ware was probably not reaching north Essex settlements very much after c 1125 (see Thetford account, pp 31-2). Thus the overlap between this industry and the nascent Hedingham industry must have been a very short one.

Though much coarser, the pale buff fabrics of some early Hedingham fine wares, together with their clear or olive-green glaze, are reminiscent of Stamford-type ware, Lincolnshire (Kilmurry 1980). The addition of plastic decoration, including slashed pads (*ibid*, fig 73.44-5 & 76), reinforces the possibility of a Stamford connection as these are all characteristics of late or developed Stamford ware, which continued in production as late as c 1250. Tubular-spouted Stamford ware jugs (*ibid*, fig 72.9) may have provided the inspiration for Hedingham ware equivalents (eg at

Rivenhall, *see above* p 82), and details such as handles with twisted strips are readily paralleled at Stamford (*ibid*, fig 78.2-9). However, no developed Stamford-type ware has yet been recognised at Colchester or elsewhere in north Essex and, like Thetford-type ware, Stamford appears to have been very scarce here after *c* 1125. Perhaps a more likely explanation for these similarities is that they reached Hedingham ware through the influence of Scarborough ware (*see below*) which had inherited them from Stamford ware.

During its lifetime Hedingham ware was influenced to differing degrees by a number of broadly contemporary ceramic industries. The strongest influences came from two of the most important and widely traded English wares of the medieval period, Scarborough ware and London-type ware. Hedingham ware represents a provincial hybrid of these and, through their influence, it acquired characteristics of both north-eastern and south-eastern English pottery traditions together with second-hand influences from the Continent. Other less obvious sources may have shaped its appearance, but the various strands of influence are not easily disentangled.

Generally speaking, the northern style of high-relief plastic decoration (often accompanied by green glaze) appears to have evolved out of developed Stamford ware. This was brought to its peak of development in Scarborough ware (Farmer 1979), and ultimately the style filtered down to a large number of lesser pottery industries along the eastern seaboard of England, penetrating inland at least as far as Nottingham. At around the same time, the Rouen style of decoration (red painted zones defined by white borders and accompanied by white dots) was disseminated throughout much of south-east England by the circulation of London-type ware (Pearce *et al* 1985). However, the occurrence of the Rouen-style on English wares must occasionally be the result of direct imitation of imported Rouen jugs (McCarthy & Brooks 1988, 57, fig 27). Similarly, northern-style plastic decoration is not entirely unknown on London-type ware and may have been copied from Scarborough or perhaps Continental wares.

In general, however, the equation of plastic decoration with Scarborough ware and the Rouen style of decoration with London-type ware is helpful in explaining certain similarities, not only between Hedingham ware and the former two industries, but also between Hedingham and a number of other provincial industries such as Lyveden, Northamptonshire and Grimston, Norfolk (Jennings 1981, 50-60). Plastic decoration, frequently of an anthropomorphic nature, and twisted rod handles are found in all three provincial industries, while versions of Rouen-style decoration are also manifest in Hedingham and Grimston wares as well as the East Anglian redwares. These industries probably came under the influence either of Scarborough ware or London-type ware, or both. Thus the explanation for their similarity is not so much that they copied or influenced each other (although this cannot entirely be ruled out), but rather that they resemble each other on account of their common stylistic relationship to Scarborough and London-type wares.

Apart from their own intrinsic interest, the full range of affinities shown by Hedingham ware has a bearing upon the date of the industry during its different phases. These are worthy of closer examination.

It was from London that Hedingham ware received its earliest definite influences, and the degree to which Hedingham jugs followed the major developments in London-type ware is quite remarkable. Hedingham early rounded jugs closely resemble the London-type jug in very many respects, such as overall form and size, the presence of heavily rilled necks, strap handles, and glazing and decorative schemes employing red and white slip decoration (Pearce *et al* 1985, 22, figs 10-18). London early rounded jugs are already present in small quantities by *c* 1140 and came into common use *c* 1150-70, but by the start of the 13th century their presence is negligible (*ibid*, 127, fig 84). Fragments of several London-type early rounded jugs are known from Colchester, and the Hedingham potters must have been equally familiar with this form. The main points of difference with London-type ware is the typical use of high-relief plastic decoration found on Hedingham early rounded jugs, which is a feature more closely associated with Scarborough ware.

The impact of Scarborough ware on Hedingham and other provincial industries has been outlined above. To varying degrees Hedingham, Nottingham, Grimston, Lyveden and other wares all seem to have come under the sway of Scarborough ware. In virtually all of these industries, one finds the occurrence of tubular-spouted jugs, twisted rod handles, face jugs and plastic decoration culminating in the flamboyant 'knight jugs' of the Scarborough and Nottingham industries with their modelled human and animal scenes (Farmer 1979; Rackham 1972, pl D, pl 12A). On many knight jugs and similar jugs, the limbs of figures and the lower ends of arched struts terminate in a splayed pad with slashed decoration imitating fingers, toes or beards. It is from these that the splayed and slashed pads seen on Hedingham ware are almost certainly derived (Fig 49.7-10). Pellet decoration in contrasting dark red clay is yet another Hedingham characteristic that could have been borrowed from Scarborough ware (Farmer 1979, pl IV). A Hedingham ram *aquamanile* from Colchester appears to have been made in direct imitation of Scarborough prototypes (PI 1; Cunningham *et al* 1983, fig 3). But, in general, Hedingham products lack the neat construction and detailing of Scarborough ware. The face masks on Hedingham jugs, for example, are much more stylised than their better-known equivalents in Scarborough and Grimston ware and lack the free-standing elements and arched struts found in these wares. Knight jugs are unknown in Hedingham ware.

Scarborough Phase I fabric, which includes the majority of knight jugs, is dated to *c* 1135-1225, but the highly decorated wares do not appear to have been produced and widely traded until *c* 1200 (Farmer *et al* 1982, 84). Certainly enough Scarborough ware was reaching Essex to have made an impact on local glazed wares (Cunningham *et al* 1983). At Harwich in Essex, Walker has pointed out that, where Scarborough and Hedingham wares occurred in the same context, the latter ware seems to imitate the former (Walker 1990a, 86).

By the start of the 13th century, London influences on Hedingham ware were largely overlain by those from Scarborough, but smaller-scale influences from London continued to make their mark throughout the century. Rouen-style jugs in Hedingham ware appear to have been made in direct imitation of the London-Rouen copies. The London copies appear *c* 1210 or slightly earlier, and continued in production throughout the first half of the 13th century (Pearce *et al* 1985, 131-2, fig 86).

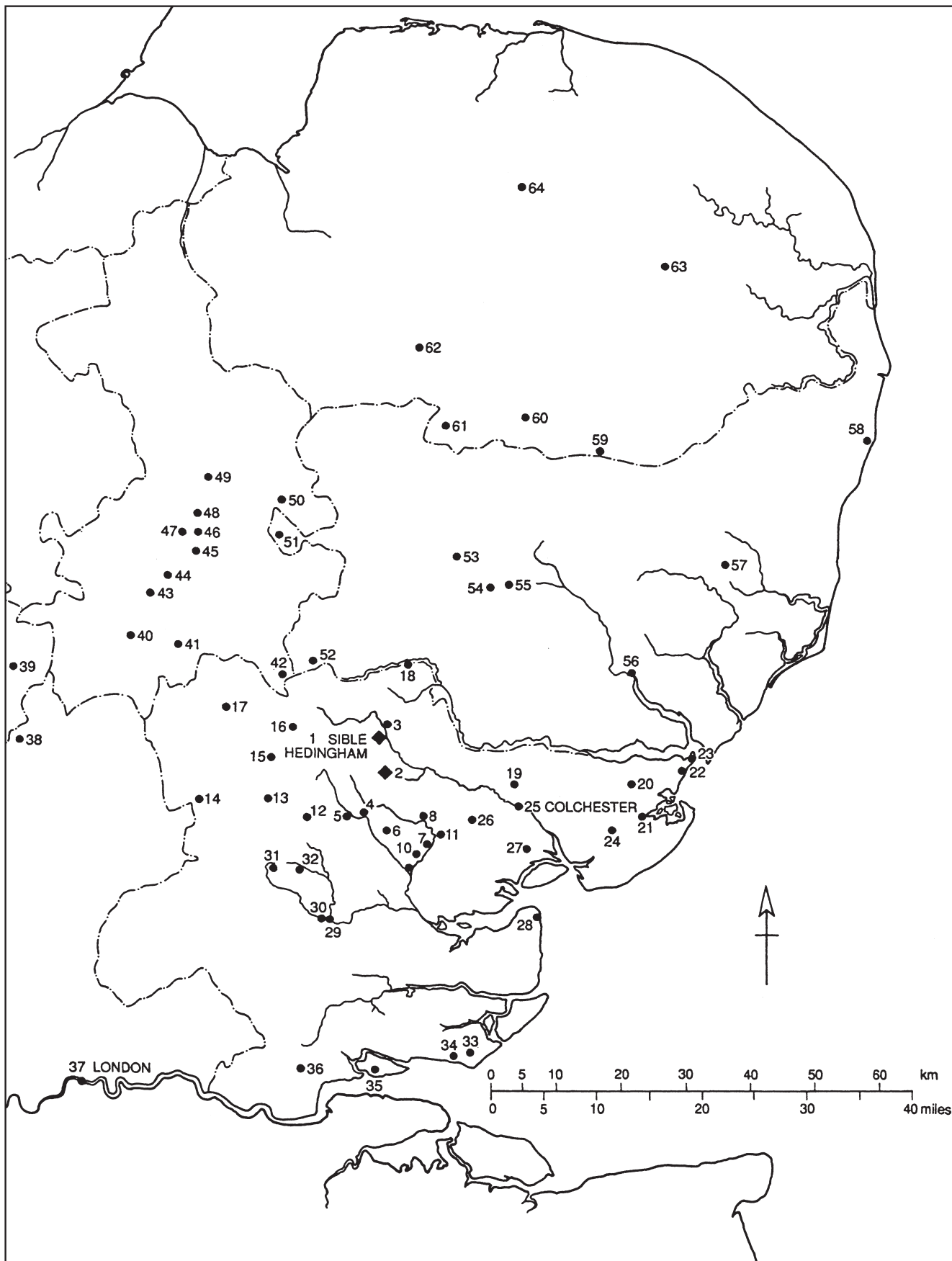

Fig 53 Hedingham fine ware: the distribution in East Anglia.

## Key to Fig 53

## Essex

- 1 Sible Hedingham (production site)
- 2 Gosfield (production site)
- 3 Castle Hedingham (Walker 1991c)
- 4 Braintree (Drury 1976b)
- 5 Naylinghurst (Drury 1976a)
- 6 Cressing Temple (identified JPC)
- 7 Kelvedon (Cunningham 1988)
- 8 Coggeshall (Walker 1988b)
- 9 Witham (CM 151.56)
- 10 Rivenhall (Drury *et al* 1993)
- 11 Feering (CM 165.1976)
- 12 Stebbingford (Walker 1996a)
- 13 Great Easton (H Walker, pers comm)
- 14 Stansted (H Walker, pers comm)
- 15 Thaxted (Eddy 1980b)
- 16 Great Sampford (Eddy 1980a)
- 17 Saffron Walden (Cunningham 1982b)
- 18 Pentlow (Walker 1991b)
- 19 Mile End (Drury & Petchey 1975)
- 20 Wix (CM 1994; identified JPC)
- 21 Beaumont-cum-Moze (CM; identified JPC)
- 22 Dovercourt (Barford 1986)
- 23 Harwich (Walker 1990a)
- 24 Weeley (Walker, in prep)
- 25 Colchester
- 26 Copford (identified JPC)
- 27 Langenhoe (CAT site X566; identified JPC)
- 28 Bradwell-on-Sea (Rodwell 1976)
- 29 Chelmsford (C Cunningham, pers comm)
- 30 Writtle (Rahtz 1969)
- 31 High Easter (Walker 1988a)
- 32 Pleshey Castle (Williams 1977)
- 33 North Shoebury (Walker 1995)
- 34 Southend (Southchurch Hall; identified JPC; Nenck, in prep)
- 35 Canvey Island (E Sellers, via H Walker, pers comm)
- 36 Horndon-on-the-Hill (Wallis 1992)

## London

- 37 Greater London (MoLAS; J Edwards, pers comm)
  - a New Fresh Wharf, FRE 78 [453] spot-date c 1150-1350
  - b Little Britain, LBT 86 [322] spot-date c 1200-50
  - c 10-11 Ludgate Broadway, WAY 83 [145] spot-date c 1230-80

## Hertfordshire

- 38 Letchworth (Green Lane, H Walker, pers comm)

## Bedfordshire

- 39 Stratton (Slowikowski 1992; identified JPC)

## Cambridgeshire

- 40 Barrington (Cambridgeshire Museum AA accession no 1947.610; identified CMC, JPC)
- 41 Whittlesford (Rackham 1972, pl 88; identified CMC, JPC)
- 42 Castle Camps (A Rogerson, pers comm)
- 43 Barton Mounts (A Rogerson, pers comm)
- 44 Cambridge (Rackham 1972, pl 41; Hurst 1966)
- 45 Horningsea (Rackham 1972, pl 33)
- 46 Waterbeach Abbey (Hurst 1966)
- 47 Landbeach (A Rogerson, pers comm)
- 48 Denny Abbey (Coppack 1980)
- 49 Stretham (T Malim, pers comm)
- 50 Fordham (A Rogerson, pers comm)

## Suffolk

- 51 Exning (Martin 1975)
- 52 Haverhill (H Walker, pers comm)
- 53 Bury St Edmunds (P Blinkhorn, pers comm)
- 54 Bradfield St Clare (A Rogerson, pers comm)
- 55 Rattlesden (A Rogerson, pers comm)
- 56 Ipswich (P Blinkhorn, pers comm)
- 57 Framlingham (P Blinkhorn, pers comm)
- 58 Covehithe (CM unaccessioned; identified JPC)

## Norfolk

- 59 Roydon (A Rogerson, pers comm)
- 60 Harling (A Rogerson, pers comm)
- 61 Thetford (Rogerson & Dallas 1984)
- 62 Hillborough (A Rogerson, pers comm)
- 63 Norwich (Dallas 1994)
- 64 North Elmham (Wade 1980)

In the stamped strip jugs found in Hedingham ware, one may see a marriage of several influences. These may include a loose interpretation of the 'North French' and 'highly decorated' styles seen in both London and Kingston-type wares as well as a number of other English wares. On Hedingham jugs, these are largely confined to the use of vertical strips on the body and rows of circular stamps on the neck, rather than the elaborate schemes seen at London and Kingston (Pearce *et al* 1985, fig 33, *passim*; Pearce & Vince 1988, fig 48, *passim*). The North French style appears in London c 1210 but, along with the highly decorated style, its main period of currency was around the middle of the 13th century, tailing off in the late 13th and early 14th centuries (Pearce *et al* 1985, 135, fig 87). However, the twisted rod handle found on Hedingham strip jugs was undoubtedly derived from Scarborough ware (Rackham 1972, pls D & F), while vertical strips on the body are also a common feature of plainer Scarborough jugs (McCarthy & Brooks 1988, fig 128.655-6). The profusion of circular stamps on the necks of Hedingham jugs mirrors the earlier profusion of red clay pellets which formerly occupied this position, and suggests an evolution from pellet/pad to circular stamp. While the pellets were probably a Scarborough influence (*see above*), the circular stamps would seem to owe something to London/Surrey influences. Late Rouen jugs are also known with rows of circular stamps on the neck and the body together with straight and curvilinear strips (Barton 1965, fig 3.12-14) and, although less likely, some influence from this direction cannot entirely be ruled out. The profusion of circular stamps on Lyveden ware could suggest a link with Hedingham (McCarthy & Brooks 1988, fig 172.1019).

Squat and pear-shaped or biconical jugs are known in the London and Kingston-type industries as well as in Hedingham ware. London-type squat jugs are already present c 1140 and have a long currency, while pear-shaped jugs are more typical of the second half of the 13th and the early 14th centuries (Pearce *et al* 1985, 19-20, fig 9), as indeed they are of Mill Green ware c 1270-1350 (Pearce *et al* 1982). Conical jugs known in London-type, Kingston-type and Mill Green wares are unknown in Hedingham ware. Rouletted decoration, common in the former two industries, is also absent.

The concurrency of late Hedingham ware and Mill Green ware c 1270-1350 and the similarity between the two wares during this period point to some connection between them. Pear-shaped jugs with vertical or oblique combed decoration and green glaze are common to both industries, and technical details such as plugged-in handles are also shared. The major difference between them, however, is that the combed decoration on Mill Green ware is a sgraffito decoration cut through a white slip, whereas Hedingham never uses an all over white slip in this fashion. This is also an important distinction between Hedingham ware and all the medieval Essex slipware industries as well as the London-type industry. Although white clay was used on Hedingham ware for plastic details (eg applied stamps and strips), white slip was never used to provide an overall slip background even though red slip occasionally was. It is not possible at this stage to say whether the combed pear-shaped jug first appeared in Hedingham ware and then was copied at Mill Green, or *vice versa*. What seems reasonably clear, however, is that the two wares were in competition and that the rise of Mill Green ware and similar Essex slipwares (such as Colchester-type ware) eventually squeezed Hedingham ware out of the market.

The similarity between the fine oxidised fabrics of Hedingham and Mill Green ware may also be significant. Visually, the only difference is the significantly higher mica content in the Hedingham fabric and its more even firing, but basically, as refined redwares, the fabrics are very similar. It is not inconceivable that the similarities between the two industries could be explained by the movement of a number of potters from the decadent Hedingham industry to the youthful Mill Green industry during the second half of the 13th century. A likely route would be along the old Roman road (the modern A12/A131) connecting London with Chelmsford as well as Hedingham with Mill Green (Ingatstone). Further work, however, would be required to test this hypothesis.

What happened to the Hedingham industry after c 1350 is entirely unknown. A number of late medieval kiln-sites or kiln dumps in the Hedingham-Halstead area have been excavated but none are published. Pottery from a kiln at Blackmore End near Sible Hedingham has been deposited in Colchester Museum (CM OS.11.1968/1-2). This, and other late medieval pottery from the Halstead area, occurs in a fabric not dissimilar to Hedingham ware (ie oxidised, micaceous), but the forms and painted designs in white slip are quite different. Perhaps, after 1350, the cohesion of the Hedingham group of potteries was dissolved and its products came increasingly to resemble other late medieval Essex redwares (Fabric 21 and perhaps Fabric 40?) along with which it enjoyed only a local circulation. Documentary evidence proves the continuation of pottery production in the area well into the post-medieval period (see Fabric 40 account, p 191).

There is no denying the outside influences which shaped the appearance of Hedingham ware during its two centuries of production, but the provincial manner in which these were selected and reinterpreted, coupled with the degree of ceramic skill available and an unusually fine clay, all contributed towards a distinctive Hedingham character.

#### 4. *Distribution* (Fig 53 — see p 88 above)

Hedingham ware was the major medieval fine ware of northern Essex, and its distribution suggests it was the most important fine ware in the southern part of East Anglia. In the Cambridge region, Hedingham jugs were the commonest non-local jugs in use followed by Grimston (Norfolk) and Lyveden (Northamptonshire) glazed jugs (Hurst 1966, 92-3).

The full distribution of Hedingham ware is only imperfectly known, but was clearly very extensive. Apart from earlier identifications by J G Hurst, Elizabeth Sellers and others (see references), most of the pottery has been identified by the author, Carol Cunningham, and Helen Walker during visits to museums and routine examination of excavated material from the region over the 10-15 years up to 1994. A more methodical examination of museum collections etc, would undoubtedly reveal a much greater number of find-spots. The relatively low number of find-spots from Suffolk, for instance, is a reflection of the lack of post-Saxon ceramic research in that county generally, rather than the lack of pottery itself.

Even with these limitations, it can be seen from Figure 53 that Hedingham enjoyed a very extensive distribution, from London in the south to North Elmham and Norwich (Norfolk)

in the north, and from Covehithe on the Suffolk coast as far inland as Stratton in Bedfordshire. A few possible sherds of Hedingham ware have even been identified from Bergen in Norway (Nita Farmer, pers comm, 1986), and the find-spots at the Essex and Suffolk ports of Colchester, Harwich, Ipswich and perhaps Covehithe (near Lowestoft) point to a degree of coastal trade that probably reached as far as London.

The circulation of Hedingham ware was clearly concentrated in north Essex, the southern half of Cambridgeshire and perhaps the south or south-western part of Suffolk. The triangular area between Chelmsford, Cambridge and Ipswich roughly defines its principal market area. Sible Hedingham was well positioned to take advantage of these East Anglian markets, but beyond its principal market area it would have encountered strong competition from other regional fine wares such as Lyveden and Grimston wares. After c 1250, Hedingham ware would have been in competition with the Mill Green industry located in south central Essex. Mill Green ware's concentration on the London and southern Essex markets almost certainly accounts for the lack of Hedingham ware in these areas, but to the north there was no comparable competition until the borders of Northamptonshire and Norfolk were reached.

Although the River Colne links Colchester with Sible Hedingham, it is unlikely that pottery was brought down river by boat as the Colne was not navigable along this stretch. Distribution inland was almost certainly by road. In Essex, one of the most likely trade routes suggested by the distribution pattern is along Stane Street to the south of Sible Hedingham and which links Colchester with other large towns such as Braintree and Bishops Stortford (Hertfordshire). Hedingham ware has been found in at least half-a-dozen places along this route. Similarly the arc described by its distribution from Stratton (Bedfordshire) through the centre of Cambridgeshire corresponds very closely to the line of Akeman Street, the Roman road linking Cambridge with Ely. The routes along the Colne and Stour valleys linking Colchester, Sible Hedingham and Cambridge led through numerous small market towns (Britnell 1986, 12), several of which have produced sherds of Hedingham ware. The inland distribution of Hedingham ware was thus almost certainly regulated through a chain of market towns lying on the main routes between the larger market towns of Essex and East Anglia. From the 13th century onwards, the wool trade to important textile towns such as Colchester, and the reciprocal dispatch of cloth, was one of the prime motives for regional trade (*ibid*, see also p 18). It could be that trade in pottery somehow took advantage of the ever-widening contacts of the textile industry, and Sible Hedingham was well positioned to take advantage of such contacts.

The 12th-century distribution of Hedingham ware beyond north Essex is difficult to verify, though Thetford (Norfolk) and certainly Denny (Cambridgeshire) may be mentioned. Otherwise late 12th- or, more likely, early 13th-century early rounded jugs are only reported from Ipswich (Suffolk), including an example with an applied slashed pad (Paul Blinkhorn, pers comm, 1987). All other examples of the ware found outside Essex appear to be from stamped strip jugs (13th century) or pear-shaped jugs (13th-14th century), apart from a Rouen-style squat jug from Whittlesford, Cambridgeshire (Rackham 1972, pl 88; c 1200-50).



## Summary

[Fig 52]

Hedingham fine ware (Fabric 22) was produced between c 1140/50 and 1350 at kilns located fifteen miles to the west of Colchester, in and around Sible Hedingham. At its peak in the 13th century, it formed an estimated 5-6% of all pottery used in Colchester, where it served as the main medieval fine ware, as it did for the rest of north Essex. During the 13th and 14th centuries, Hedingham ware was extensively traded throughout Essex and East Anglia, but the Chelmsford-Cambridge-Ipswich triangle comprised its principal market area. Small quantities, however, were traded as far as London, Norwich and possibly Norway. Jugs formed the main output although the production of luxury items, such as *aquamaines*, is also notable. Hedingham jugs display strong influences from both the London and Scarborough pottery industries and later on perhaps from the Mill Green ware industry as well (or *vice versa*). Competition from Mill Green and the East Anglian redware industries may have brought about the decline of the Hedingham industry in the later 13th and 14th centuries.

Hedingham jugs passed through a number of distinct styles for which the following dates are tentatively suggested:

- 1a. 'London-style' early rounded jugs. Large rounded jugs with ribbed necks, broad strap handles and painted red lattice decoration on the body. Date c 1140/50-1200.
- 1b. 'Scarborough-style' large early rounded jugs with strap handles. High-relief plastic decoration including pellets, strips (plain, twisted or notched), pear-shaped or circular pads (plain or slashed), anthropomorphic faces. Date c 1175/1200-1250.
2. 'Rouen-style' jugs (copying London-Rouen jugs), large and smaller rounded, squat and possibly baluster jugs. Strap, rod and twisted rod handles. Red and white polychrome decoration. Date c 1200-1250.
3. Stamped strip jugs. Smaller rounded and squat jugs with twisted rod handles (London/Surrey and Scarborough influences). Stamped pads on neck, vertical strips on body sometimes over red slip. Date c 1225-1300/25.
4. Pear-shaped jugs (?copying Mill Green ware). Squared handle with vertical grooves, combed decoration or horizontal reeding on body. Date c 1250/75-1350.

## Medieval sandy greywares (Fabric 20)

[Figs 54-68 & 247]

Weight: 148.2 kg

Number of sherds: 9,748\*

EVEs: 61.90\*

## Fabric

The fabric is hard to very hard and sandy with dark grey surfaces, and commonly a dark red-brown core or a lighter grey or sandwich-effect core. Dull brown surfaces are not

uncommon, and completely oxidised examples occur but are fairly rare. Quartz sand is abundant, medium-coarse, rounded and sub-rounded, clear or opaque. There is a moderate amount of red and black iron oxide which can be very coarse, and sparse quartz and flint grits up to 5 mm across. The matrix contains much fine mica. The principal differences between this fabric and its parent fabric, early medieval sandy ware (Fabric 13), are the more uniform grey firing, the increased hardness and the density of the matrix compared with the 'open' texture of Fabric 13. A further general improvement in fabric quality — linked, no doubt, to improved methods of clay preparation, vessel manufacture and firing — is detectable from the late 13th century onwards. Vessels become thinner-walled, and the fabric is denser and more homogeneous, more often with a reddish core and prominent grains of grey-white quartz contrasting with the grey matrix. The Fabric 20 category used for grey coarsewares at Colchester also includes a few miscellaneous fabric variants which may be from outside the area. Significant variants are noted in the catalogue below.

## Dating and frequency

[Figs 54 & 247]

Fabric 20 developed from Fabric 13T during the second half of the 12th century, perhaps within the last quarter of the century. The typical squared externally flanged rim (H1) of

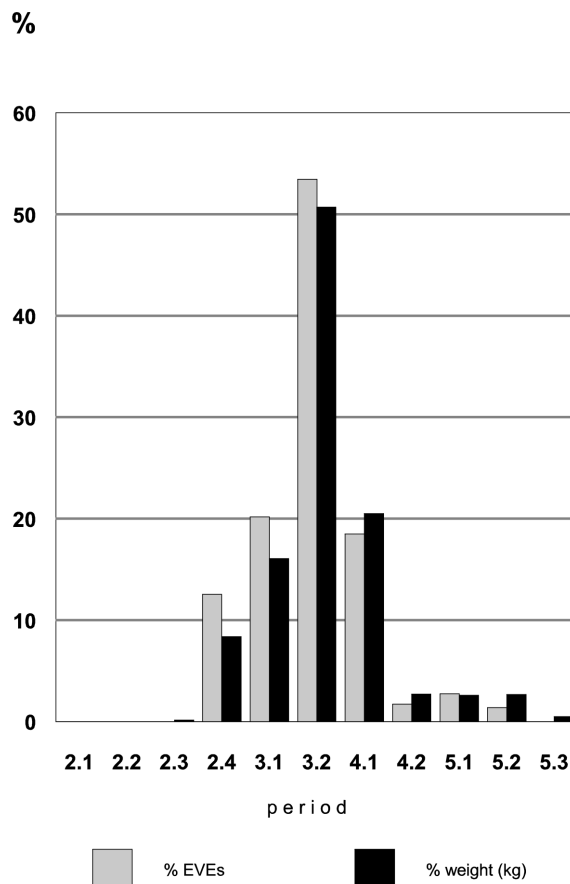

Fig 54 Medieval greyware: bar chart showing percentages in stratified contexts (ceramic periods).

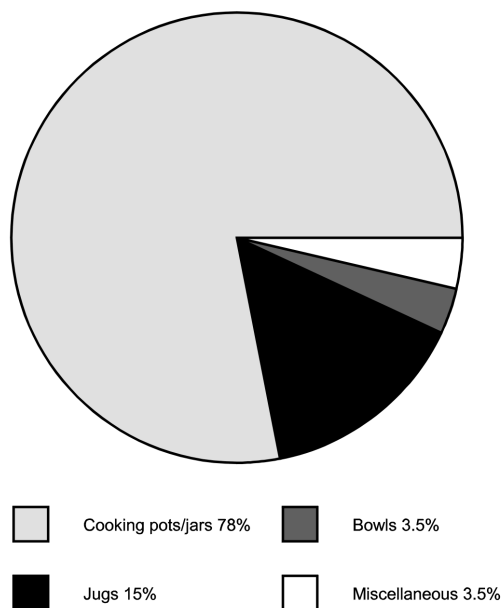

Fig 55 Medieval greyware: pie chart showing vessel assemblage by EVEs.

Fabric 20 cooking pots is presaged in the latest group of kilns at Middleborough (Fabric 13 or 13T), somewhat towards the end of the proposed date-range of c 1175-1225. Fully developed squared rims (Fabric 13T), almost certainly derived from the kilns, were found in the 'potter's workshop' (Building 74) and surrounding topsoil, contemporary with the kilns (see p 57). A small quantity of Fabric 20, including a squared rim, is already present in Period 2.2-4 (LWC D Period 1, c 1100-1200). In the Lion Walk ditch sequence (Stratified Group 4), Fabric 20 occurs in a layer of c 1200-25 (LWC NF2104). In the successive layer (LWC NF2105) dated c 1225-1300, Fabric 20 is the dominant ceramic type. This predominance continues through the 13th and most of the 14th century: in Period 3.2 (c 1250/75-1400), the fabric comprised over 50% of all pottery used in the town (Fig 54). Thereafter the decline was rapid. Unlike Fabric 13 and Fabric 21, the end of Fabric 20 was relatively abrupt since, unlike these fabrics, there was no transitional phase giving rise to a successor fabric. The decline of Fabric 20 can probably be explained by the increasing availability of metal cooking vessels which were more durable than their ceramic equivalents. By 1301, 44% of Colchester's taxable population owned one or more metal vessels (Le Patourel 1968, 101). With the decreasing demand for ceramic cooking vessels and with the demand for jugs and storage vessels increasingly satisfied by visually more attractive fabrics (Fabrics 21 and 21A and non-local wares), the need for Fabric 20 no longer existed.

Fabric 20 is still well represented in a layer sealing the Lion Walk ditch (LWC NL4, Period 3.2) which contained a coin probably lost c 1350-75 (CAR 4, 65), but could be as late as c 1400. It persists as a residual element in 15th century and later contexts (eg Stratified Group 11). In a group of over 200 sherds from a robber trench associated with the re-facing of the town wall c 1382-1421, only a single sherd was in Fabric 20 (Stratified Group 9). As remarkably little other pottery from this context was obviously residual, it is

reasonable to assume that Fabric 20 had disappeared by this date, and probably by c 1375-1400. Whether medieval sandy greywares continued to be produced in other parts of Essex has yet to be demonstrated.

### Sources, parallels and distribution

'Fabric 20' is the term used to describe unglazed medieval Essex coarsewares in general, but in the case of Colchester there is little doubt where these were coming from. Mile End and Great Horkesley products have been assigned codes in the extended Essex system for recording medieval pottery (Fabrics 20A and 20B respectively), but in practice the grey coarseware from these sites cannot easily be distinguished except, perhaps, on the basis of typology. The coarseware element of the Heddingham and Mill Green industries is also covered by this code (Fabrics 20D and 20C respectively), but no definite examples of these coarsewares have been recognised from Colchester (although see storage jars, below).

In north Essex, medieval coarsewares tend to be grey (ie reduced), as is demonstrated by the Mile End, Great Horkesley and Heddingham products. There is also, in north Essex, a fairly sharp distinction between glazed oxidised 'table wares' (ie jugs) and unglazed reduced 'kitchen wares' (ie cooking pots), at least for the 13th to 14th centuries when large cooking pots were produced. Fabric 20 therefore can be seen as the coarseware or 'kitchen ware' element of a number of similar industries that also produced a fine ware or 'table ware' element, eg in the form of glazed Heddingham and Colchester-type ware jugs (Fabrics 22 and 21A). In south and central Essex, although reduced wares are sometimes found, this colour distinction is much less marked. The dominant coarseware here was Mill Green coarseware, a predominantly oxidised (orange) fabric (Pearce *et al* 1982, 289).

Because of the similarity of coarse greywares in north Essex, it is difficult to establish the source, and hence the distribution, of all but the most distinctive products. The distribution of Mile End products was probably not great, and Colchester was undoubtedly the main market for these wares. However, a distinctive Mile End rim form occurs at Harwich sixteen miles east of the kiln-site (Walker 1990a, fig 5.26, compare with Drury & Petchey 1975, fig 6.27), and several other vessels from Harwich could also be from Mile End. A Mile End-type 'basket'-handled bowl (as Fig 61.31) has been identified (by the writer) from the Chequers Hotel site at Maldon fifteen miles south-west of the kiln-site, and a number of other vessels from Maldon have tentatively been ascribed to this source (Walker 1992a, fig 32). In view of these occurrences, the distribution of Mile End coarseware may have been limited to a radius of 15-20 miles from the kiln-site.

It is likely that medieval sandy greywares were produced at numerous locations in Essex (and neighbouring counties), but that the majority of these production sites await discovery. A few Fabric 20 variants from Colchester contain either shell or limestone inclusions and are unlikely to have been produced in the immediate area (see below, storage jars and curfews), and there are some vessels, including a jug from Frinton (Fig 65.52), fifteen miles east of the town, that are distinctive enough to suggest that they must come from a source other than Mile End or Great Horkesley. A

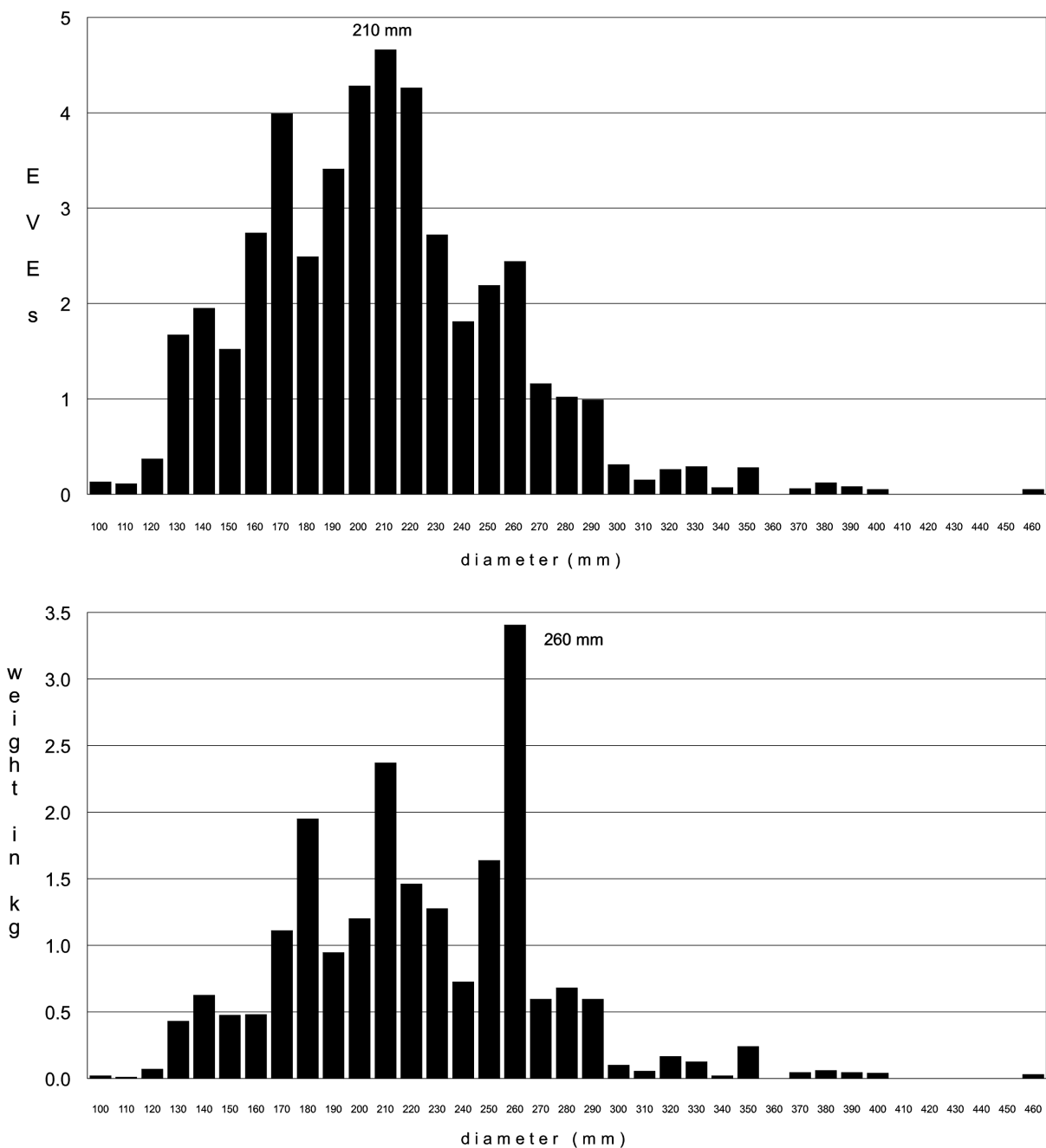

Fig 56a-b Medieval greyware: bar charts showing diameters of cooking pot/jar rims by EVEs and weight.

Johanne le Pottere is recorded at St Osyth near Clacton in 1327, so perhaps there was some pottery production there (Ward 1983, 9).

Although no definite Heddingham coarse-ware (Fabric 20D) products (12th century onwards) have been identified from the excavations, the plainer Heddingham cooking pots are similar in form to those from Colchester and would be difficult to tell apart (eg Drury 1976a, fig 8.118-25, fig 9.126-8). Some 14th-century (Fabric 20D?) cooking pot wasters from Gosfield, near Halstead, are also completely plain (Petchey 1976, fig 14.1-8). The Gosfield kilns probably formed the southern limit of the Heddingham group (*ibid.*, 178). Sandy greyware also seems to have been produced at the kilns at

Danbury, near Chelmsford, in the late 13th to 14th centuries (Drury & Pratt 1975, 127-32, fabric 'A'). Late 13th- to 14th-century kilns may also have existed at Potters Row, Tiptree, nine miles south-west of Colchester, where large quantities of Fabric 20 have been collected (*see* Appendix 2, p 369). Another production site may have existed in the Tollesbury area also nine miles south of Colchester. Cooking pots from there have a distinctive fine mid-grey fabric and very simple everted rims (CM 05.7.1968), and field names in the vicinity, such as Potter's Piece and Potter Row Pasture, are also suggestive of ceramic activity (Chapman Waller 1898, no 148). Pottery similar to that from Tollesbury has been found at the moated site of Blind Knights at Abberton, only four miles south of Colchester. The likelihood, then, that

some other production sites were supplying Colchester with medieval sandy greywares is high, although these sources were probably insignificant compared to Mile End and Great Horkesley.

**Cooking pots** (Fig 58.1-9, Fig 59.10-17 & Fig 60.18-21)

These account for over three-quarters of all vessel forms (Figs 55 & 67). Cooking pot forms continue those found in Fabric 13 though with a greater emphasis on globular forms. Rim diameters range from around 110 to 300 mm with perhaps one or two vessels smaller or greater than this (Fig 56). The emphasis, however, is still on cooking pots of approximately 210-220 mm, just as it was for Fabric 13 and several other Essex coarseware industries. In general the earlier cooking pots have a squared appearance with a slight shoulder, a short upright neck and a squared or thickened flat-topped rim (Fig 58.1-6). Squared rims (H1, eg Fig 58.1 & 4-6) comprise 46% by EVEs of all cooking pot rims, while thickened flat-topped rims (B2, eg Fig 58.2-3) comprise 7%. The latter type may be sub-squared and often slightly hollowed on top like Fabric 13 rims. Later cooking pots tend to have a more rounded, globular profile with a blocked, neckless rim (H3, Fig 59.14-17 & Fig 60.18). Such rims comprise 26% of the total. The difference between the squared rim (H1) and the blocked, neckless rim (H3) can be

measured, roughly, by the internal angle of the rim. On squared rims this is close to a right-angle or greater, while on blocked rims the angle drops to around 45-50 degrees. The transition from squared to blocked neckless rims is often the only tool by which Fabric 20 cooking pots can be approximately dated. Squared rims are present on the earliest Fabric 20 cooking pots. Blocked and (virtually) neckless rims, perhaps transitional, make their earliest possible appearance in a pit dated *c* 1225-75 (Stratified Group 7, Fig 218.10-12 & 15). In the Lion Walk ditch sequence, squared rims are present in a layer of *c* 1225-1300 (Stratified Group 4, Fig 213.40 & 42). Neckless rims appear in the succeeding layer which, in its upper level, contained a coin minted 1335-43 and lost *c* 1350-75 (LWC NL4; *CAR* 4, 65). This picture is repeated in numerous sequences in Colchester and elsewhere in Essex. At Danbury, the changeover occurred by *c* 1275/85-1325/35 (Drury & Pratt 1975, 127-32). At Mill Green, where production dates from *c* 1250/75 onwards, the vast majority of cooking pots also have neckless rims (Pearce *et al* 1982, fig 17.49-53; Meddens & Redknap 1992, fig 21.101-113). Neckless rims of this type already occur on sandy/shelly fabrics in contexts of *c* 1220 and *c* 1225-35 at the Tower of London (Redknap 1983, fig 8.13-16 & fig 12.96-7), but this might be unrelated to developments further north. Stratified Group 7 at Colchester (*see above*) is only dated to as late as *c* 1275 because of the presence of neckless cooking pot rims. However, all the other fabrics present, particularly the London-type Rouen-style jug, are all consistent with a date of *c* 1250 or earlier. On this basis, the introduction of neckless cooking pot rims at Colchester could likewise have occurred by *c* 1250 and had almost certainly occurred by *c* 1275.

Examination of whole or nearly whole profiles reveals that many Fabric 20 cooking pots continued to be manufactured using the same techniques which were used to make Fabric 13 cooking pots. A wheel-turned rim and shoulder was added to a hand-made body. Subsequent wheel treatment and knife-trimming skilfully disguise almost totally any external indication of this process. Internally, however, the composite nature of the vessel is revealed by the change from a regular wheel-turned surface above the shoulder, to an irregular dented surface below this (eg Figs 58.1-4, 57 & 63). This process was executed with rather more skill than on Fabric 13 cooking pots. The inner junction seems to be lower down and less distinct than this earlier fabric and, without the lower half of the vessel, it is not usually possible to distinguish it from a wholly wheel-made example. Re-examination of the published cooking pots from Mile End reveals that these too were very often of composite construction despite the thinness of the walls. Composite manufacture was noted on both plain everted and square-rimmed cooking pots at Mile End. In Colchester itself, it appears that composite manufacture is most commonly associated with squared and thickened flat-topped rims (Fig 58.1-5). While similar rims occasionally occur on wholly wheel-made vessels, cooking pots with blocked neckless rims appear to be wholly wheel-made. Four of the five illustrated cooking pots of composite manufacture come from contexts apparently of late 12th- or early 13th-century date. The earliest possible blocked neckless rim profile (Stratified Group 7, Fig 218.10) is wholly wheel-made. Small, almost straight-sided cooking pots (Fig 59.11-12) appear to be wholly wheel-made and are almost certainly a late development, as the form is continued in Colchester-type ware (Fabric 21A). These are fairly rare in Fabric 20.

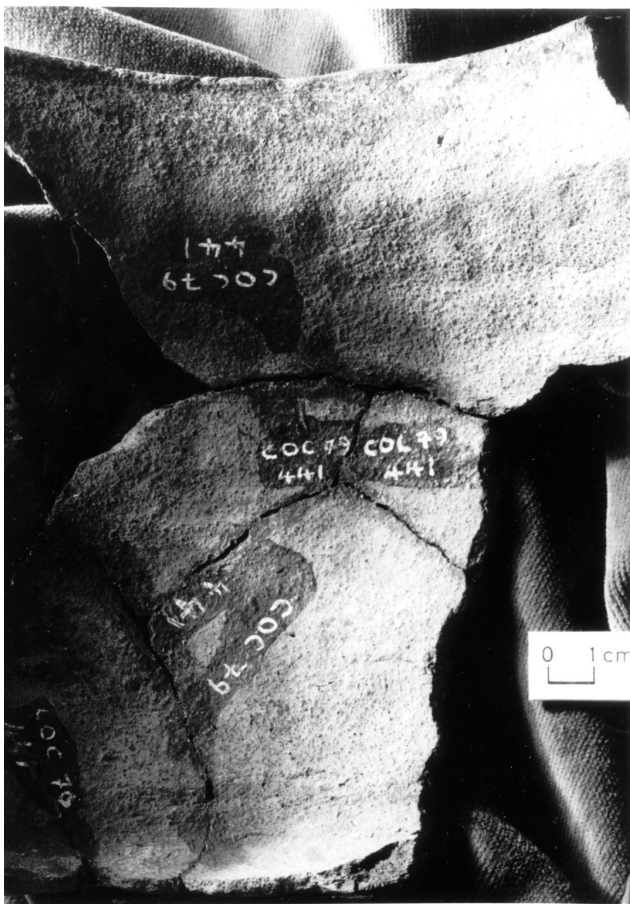

Fig 57 Medieval greyware: internal detail of cooking pot (no 4) showing evidence of composite manufacture.

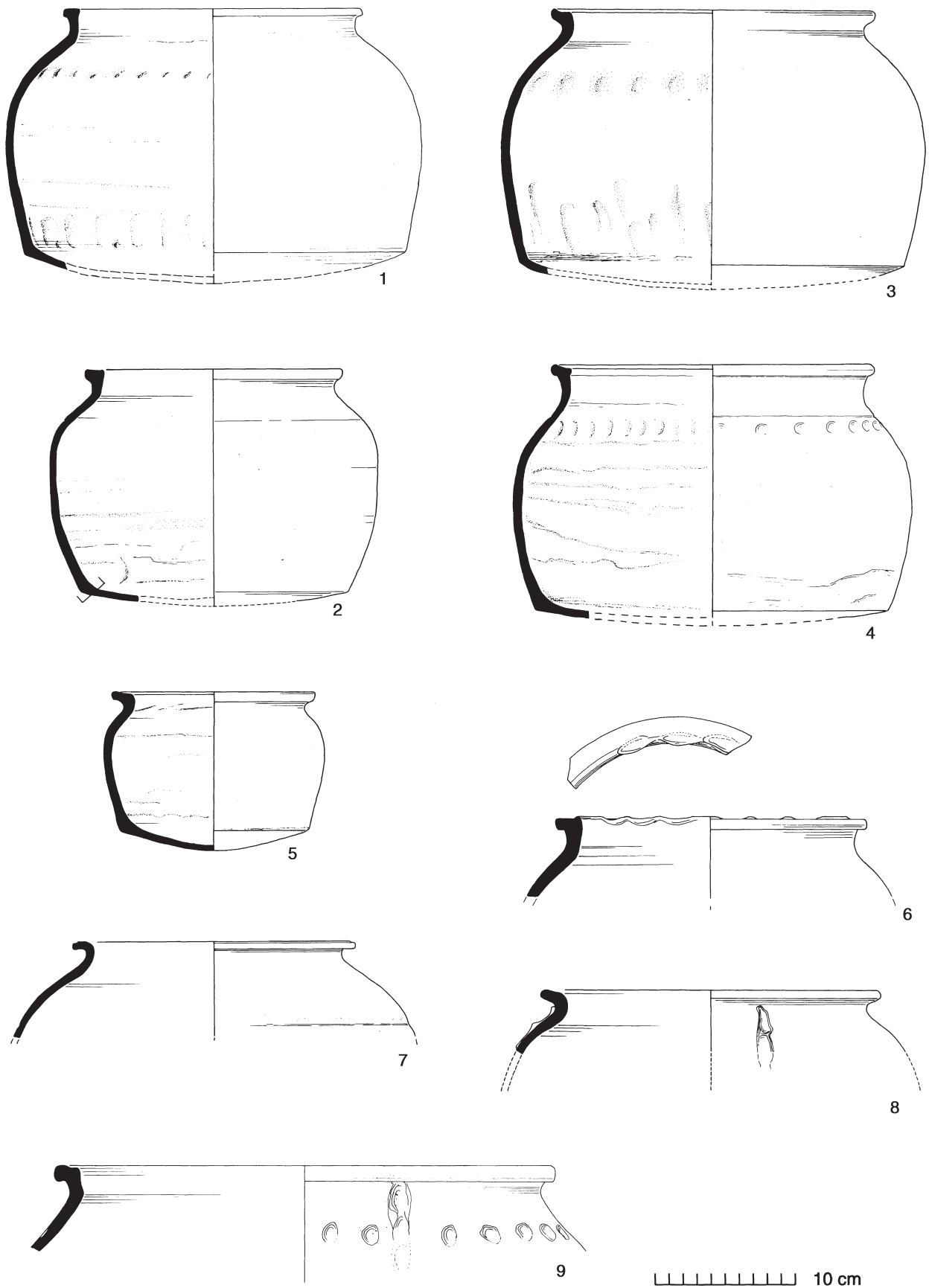

Fig 58 Medieval greyware: cooking pots (nos 1-9). 1:4.

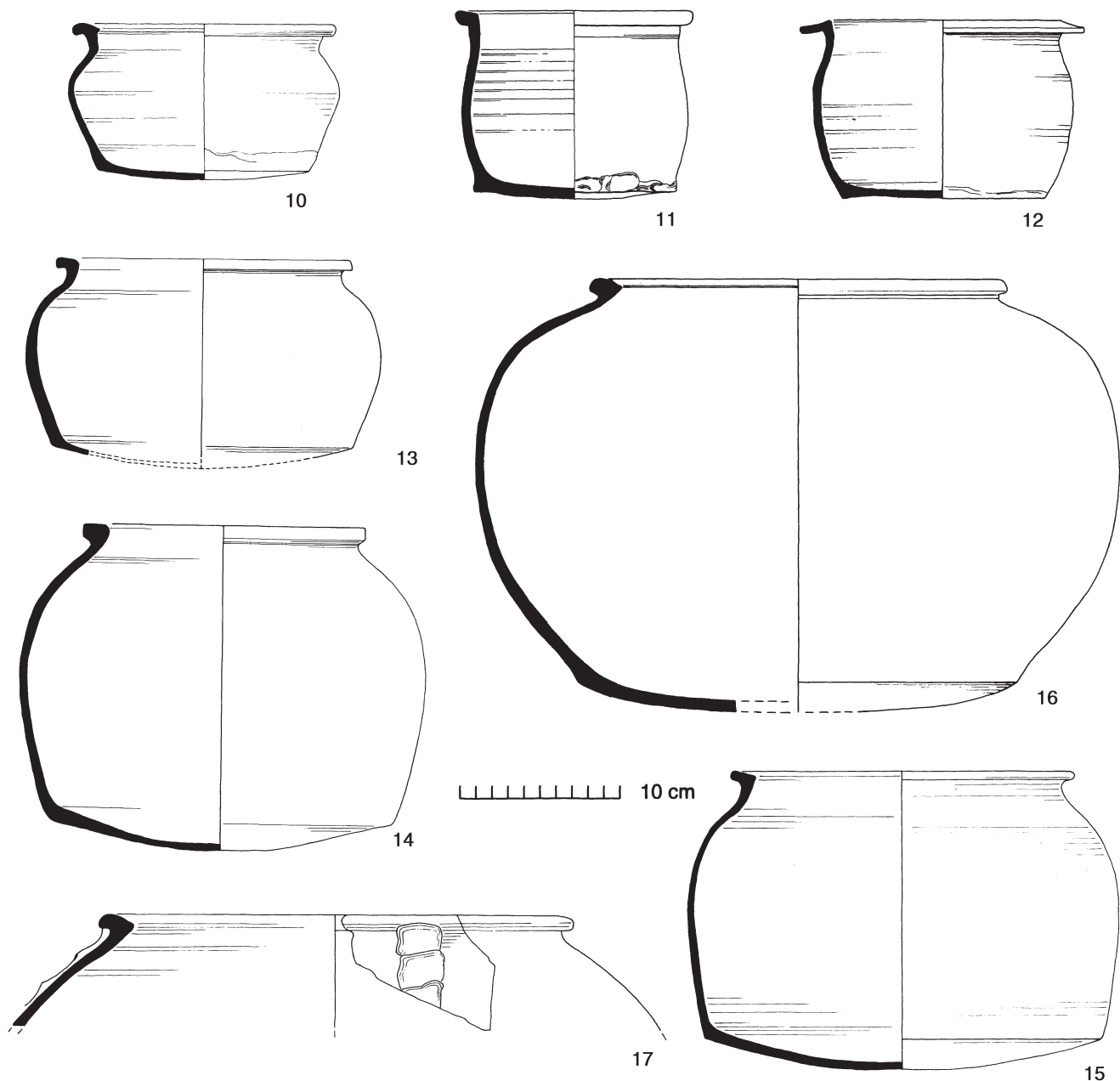

Fig 59 Medieval greyware: cooking pots (nos 10-17). 1:4.

A development of the squared rim is that of the broader flanged rim (6%), sometimes angled or slightly hollowed (Fig 59.12 & Fig 60.19-20). Mile End-type cooking pots, with curved everted rims of Group III and globular bodies, are curiously uncommon in the town (Fig 58.7-8). Such rims comprise only 8% despite their predominance at Mile End. Further, the earliest stratified example does not occur until Period 3.1 where it is associated with a coin lost c 1280-1320 (CAR 4, 66), and they do not become relatively common until Period 3.2 (c 1250/75-1400). This suggests that the type had a long currency or, though perhaps less likely, that the dating of Mile End should be revised, or that the Colchester rims are residual. Other differences between Mile End forms and those found in the town are noted below. Rim types other than those already mentioned are of

very minor significance; these include an unusual deeply-stabbed rim (Fig 60.21) which may be a non-local product.

Six per cent by weight (or 10% by EVEs) of all sherds and all forms in Fabric 20 have some sort of decoration, excluding applied thumbed strips (3.5% and 5% respectively); 8.5% (by weight) of all cooking pots are decorated (4.3% by EVEs). No type of decoration is particularly common. Thumbed strips, both functional and decorative, are the commonest type of decoration on cooking pots (Fig 58.8-9 & Fig 60.19 & 21). Other types of decoration include a groove and dimples on the shoulder (Fig 58.4 & 9), girth grooves, and occasional stabbed or lightly thumbed rims (Fig 60.21 & Fig 58.6), but in the main Fabric 20 cooking pots are much plainer than their Fabric 13 predecessors. The later neckless rim cooking pots are particularly plain.

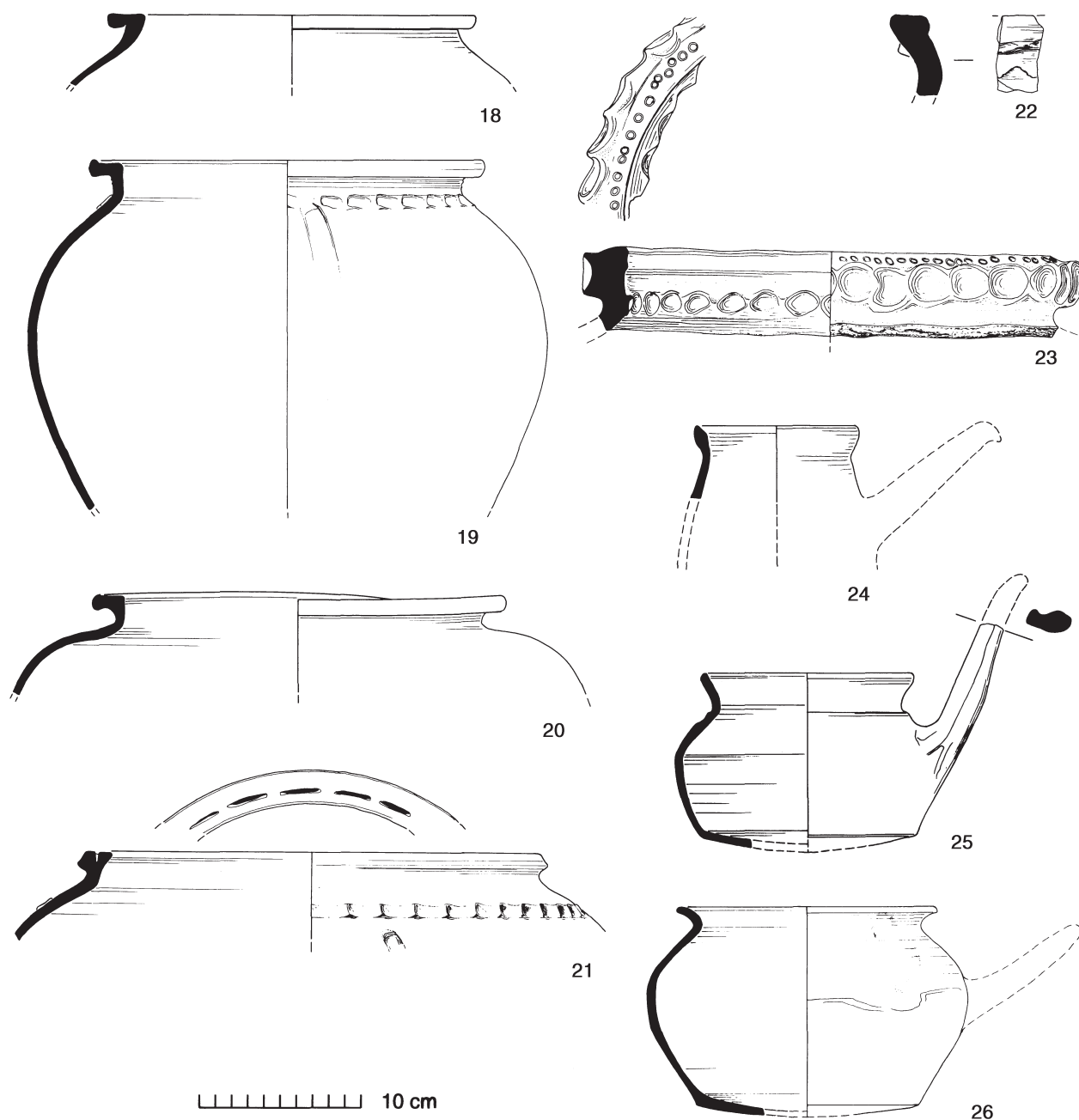

Fig 60 Medieval greyware: cooking pots (nos 18-21); storage jars (nos 22-23); skillets or pipkins (nos 24-26). 1:4.

#### Function

There can be little doubt that the majority of vessels described above were actually cooking pots used for the preparation of food. The bases and sides of most of these vessels showed varying degrees of sooting from their use over or next to a fire. A small number of vessels display a restricted band of sooting covering the rim and neck only (eg Stratified Group 7, Fig 218.13). This could be the result of the specialised preparation of certain types of food in which the earthen vessel was placed inside a metal vessel full of boiling water, over a fire. Certain medieval recipes exist that give just such instructions, and examples of

sooting presumed to result from this technique are known from other sites (Moorhouse 1983b, 183). An unusually large and virtually complete cooking pot of late 13th- or 14th-century type (Fig 59.16) was found in a tile-built oven in the service rooms of Building 76 on the Middleborough site (CAR 3, fig 178; F487). Much of the upper part of the pot lay upside-down, resting on the oven floor. The pot shows no obvious signs of use. Figure 59.11 has a thick white deposit covering the lower inside surface. The deposit has not been analysed, but it resembles the uric compounds seen in post-medieval chamberpots and this may have been the function of this particular pot.

Excavations in the garden of St Mary's rectory in Colchester, by the Colchester Archaeological Group, uncovered a cooking pot which was 'recessed and cemented' into a Roman tessellated pavement lying at a depth of three feet (0.91m). The floor at this point appeared to be a repair made with white cement (Erith 1966, 49, fig 26). The pot is in Fabric 20, of late 13th- or 14th-century type, and shoulderless with a horizontal flanged rim and prominent girth grooves. The purpose for its burial is unknown, but recessed pots elsewhere in Britain have been interpreted as sumps, as fermentation units, or as charms to ward off evil spirits (Moorhouse 1986, 115-17).

## Bowls

[Fig 61.27-32, Fig 62.33-38]

Bowls are the third most common form in this fabric. It is unclear whether the shouldered forms (eg Fig 61.27-31) were hand-made and subsequently finished off on the wheel or turntable, or whether some were completely wheel-made. Probably the former is most likely, as the lower walls are sometimes irregular and in any case the larger vessels would have been extremely difficult to turn on the wheel. Bowls with broad flanged rims or straighter sides are more likely to have been extensively wheel-turned if not wheel-thrown (eg Fig 61.32, Fig 62.38).

The majority of bowls have gently curving sides, but a few are almost straight-sided. Flanged rims comprise 40% (by EVEs) of all bowl rims, horizontal flanges being commonest (20%, eg Fig 61.28), followed by down-turned flanges (11%, Fig 62.38) and plain or hollowed flanges (eg Fig 61.32). Externally thickened flat-topped rims (eg Fig 62.33-37), the second most common rim type, comprise 23%. Squared rims comprise 13% (eg Fig 61.27, 29-30), though these are rather similar to flanged types. The remaining rim types appear in the figures. Bases, where surviving, are sagging and sometimes show evidence of external knife-trimming. Bowls vary from 150 to 540 mm in diameter, perhaps with a slight clustering around 250 mm.

Fabric 20 bowls are common from Period 3.1 onwards. Wide, shouldered bowls with steep sides and squared or flanged rims (Fig 61.27-30) are typical of the Mile End kilns, and are probably the bowl equivalent of the vertical necked, squared-rim cooking pot (Drury & Petchey 1975, fig 6.31-2 & fig 10.56-7). A single basket-handled bowl (Fig 61.31, Period 3.2) is also paralleled at Mile End (*ibid*, fig 7.36b) and a virtually complete example, straight-sided but with similar thumbled and stabbed handles, was recently found at Maldon (unpublished, *see above*). The small bowl with stabbed piecrust rim (Fig 62.33) was associated with a coin lost c 1280-1320 (*CAR* 4, 66), and continues a type first seen at Mile End (Drury & Petchey 1975, fig 8.38). Wide, flanged bowls (Fig 61.32) make their appearance in a Lion Walk ditch context c 1225-1300 (Stratified Group 4), and the common horizontal or down-turned flange (Fig 62.38, Period 4.1) is only common after c 1250/75 (Period 3.2; *see also* Cunningham 1982a, fig 27.33-4). Two such bowls occur in association with a coin lost c 1350-75 (LWC NL4; *CAR* 4, 65). These later bowls, typified by pronounced flanged rims and steep shoulderless sides, are not paralleled among the early 13th-century material from Mile End, but they are paralleled among late 13th- and early 14th-

century material from Great Horkeley (Drury & Petchey 1975, fig 13.80 & 83) and Danbury (Drury & Pratt 1975, fig 60.B7 & E4). These flanged and straight-sided forms are probably the bowl equivalent of the neckless cooking pots with which they commonly occur, perhaps c 1250/75-1375/1400.

Decoration occurs on about a fifth of all bowls. Light thumbing sometimes occurs on Mile End-type bowls with squared rims (Fig 61.29), and on Figure 61.28 is accompanied by light dimples on the shoulder. This treatment mirrors that sometimes found on square-rimmed cooking pots, though thumbing may occur on other types of bowl (Fig 62.33, 35-36). Figure 62.36 is reminiscent of Fabric 13 bowls and is most unusual in having a speck of clear glaze on the rim, possibly suggesting non-local manufacture. Stabbed rims and incised lines are comparatively rare (Fig 62.33-34). The decoration on the handles of basket-handled bowls (Fig 61.31), particularly the thumbled edges and stabbed slashes of the Maldon example, is the same as that used for jug handles.

The function, particularly of the largest bowls, remains uncertain, but it has been suggested that they may have served as cream pans used in the production of butter (Drury & Petchey 1975, 57). Several Colchester examples, however, including the basket-handled bowl, are heavily sooted from use as cooking vessels.

## Jugs

[Fig 64.40-43, Fig 65.44-52]

These are the second commonest form in Fabric 20. Jugs in this fabric first appear in Period 3.1 and presumably developed from Fabric 13/13T jugs in the late 12th/early 13th century. Whole profiles are rare but enough survive to demonstrate that some, apparently the earlier ones, continued the tradition of composite manufacture inherited from early jugs in Fabric 13. This is clearly seen on Figure 64.41 (*see also* Fig 63) from a context of c 1225-75 (Stratified Group 7) and on Figure 64.40 (CM). The earlier jugs are wheel-made from the shoulder upwards, but the body and the base were separately made by hand. Handles were secured to the neck by pushing through from the inside with a sharp tool so that the incision skewered both neck and handle. The incision is sometimes plugged with clay. This process was repeated for the lower junction where finger thrusts often replace the sharp tool. Some jug handles were anchored to the vessel by a slightly more sophisticated development of the above method. The end of the handle was first moulded approximately to shape before the addition of a clay blob which acted as a plug or rivet when pushed through a circular socket in the neck. The plug was then smoothed over. Most later jugs, those of the later 13th and 14th centuries, appear to be wholly wheel-made (Fig 65.49-52).

Complete jug profiles in Fabric 20 are rare at Colchester, but at least three forms can be distinguished and their development inferred from stratigraphic evidence and external parallels. The first and probably the earliest form is the rounded jug (Fig 64.40-41), which has the same basic body form as cooking pots, but is somewhat narrower, and may even have a squared cooking pot-style rim, with a short flaring neck (Fig 64.40) or a cylindrical ribbed or



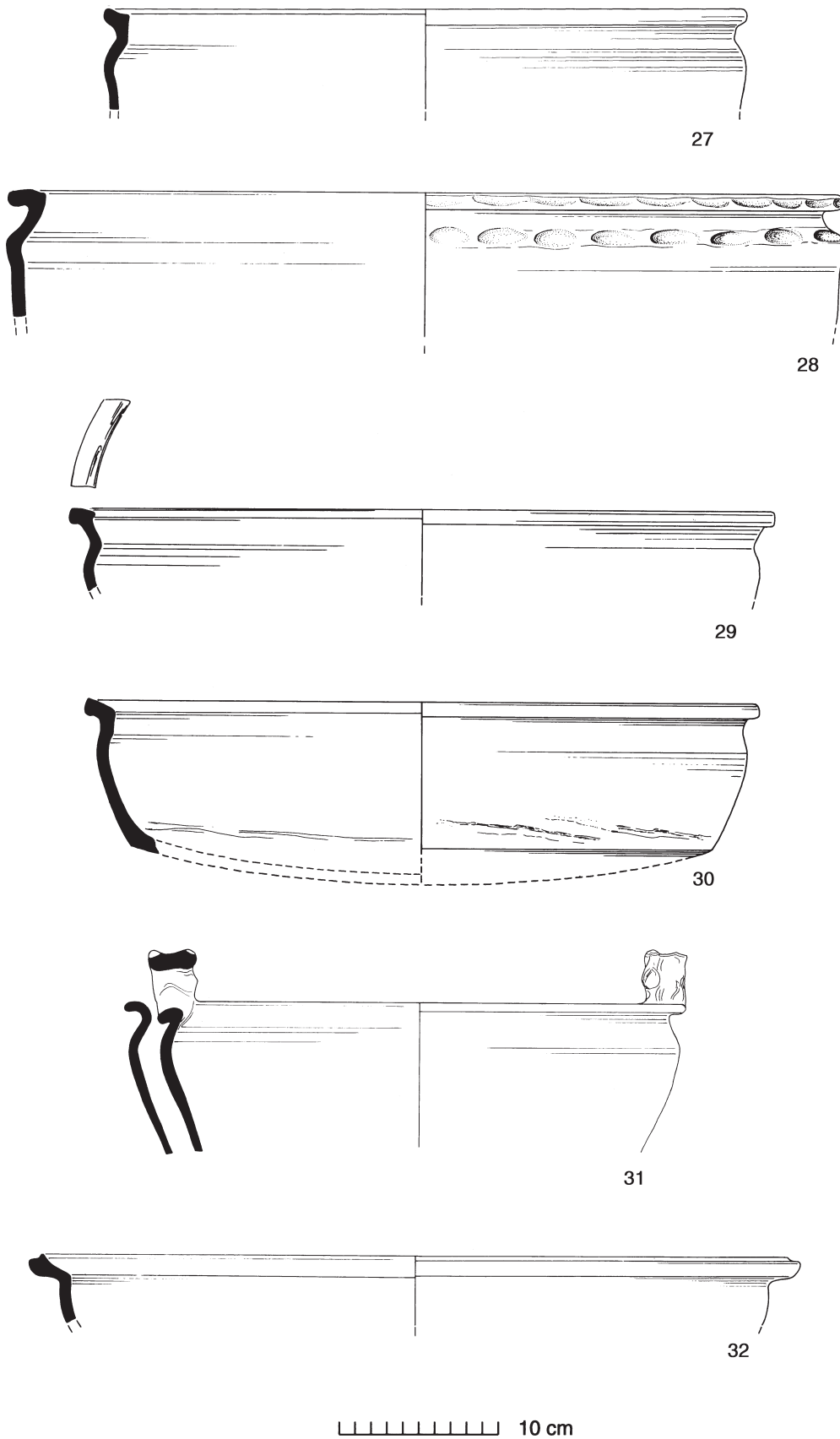

Fig 61 Medieval greyware: bowls (nos 27-32). 1:4.

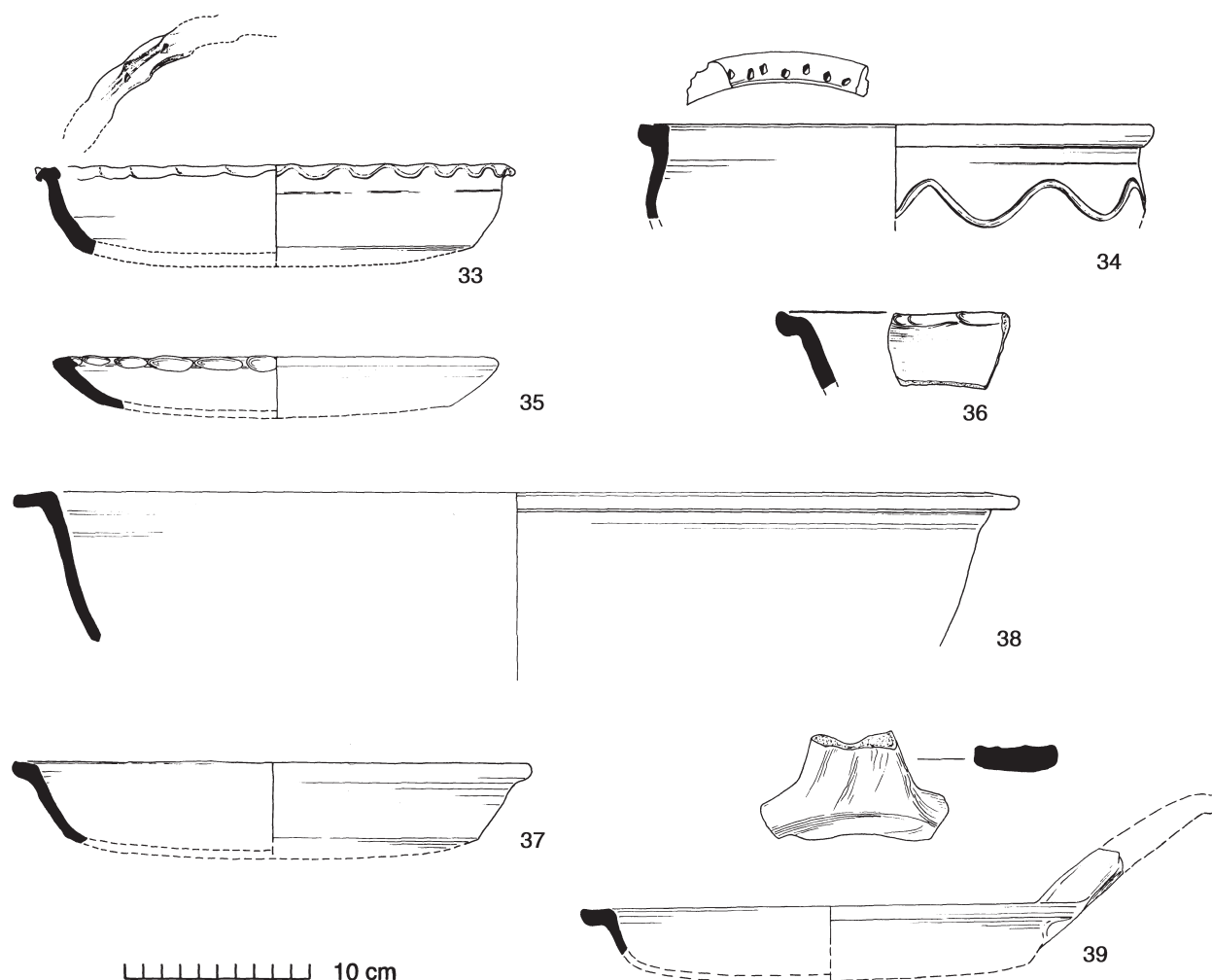

Fig 62 Medieval greyware: bowls (nos 33-38); frying pan (no 39). 1:4.

corrugated neck with a pulled lip (Fig 64.41). This is the same basic form as the jugs produced at Mile End, though the ribbed neck is more developed there (Drury & Petchey 1975, fig 4.1-5). It is curious that the thumbled jug base, so common at Mile End, is represented by only a single example from the excavations in Colchester and by two smaller jugs in Colchester Museum (Fig 65.51-52). The lack of jugs decorated in this fashion and the relative scarcity of Mile End-style 'cavetto' cooking pot rims (noted above) is difficult to explain unless, perhaps, the production of these features was experimental and short-lived. The rounded Fabric 20 jug form at Colchester (and perhaps throughout Essex) was probably a loose copy of 'early rounded' jug forms in London-type ware or Hedingham ware. This form was also produced at the late 12th-/early 13th-century Hole Farm kilns at Hedingham in grey coarseware. Interestingly, the pair of finger-impressed dimples on the rim of Figure 64.40 also occurs on vessels from the Hole Farm kilns, although this example is probably not a Hedingham product. As rounded jugs are hand-made, they are most probably contemporary with the production of hand-made Fabric 20 cooking pots with squared rims, ie c 1175-1250/75. Rod handles are a

feature of early Fabric 20 jugs elsewhere in Essex (Carol Cunningham, pers comm).

Squat jugs (Fig 64.42-43 & Fig 65.49) overlap in form and date with rounded jugs, but probably continued in production until the end of the industry. Some were almost certainly hand-made with a wide, squat, hand-made body and a wheel-turned and prominently ribbed cylindrical neck and generally with a simple everted rim and a stabbed or decorated handle (Fig 64.42-43). This form may also have been produced from the late 12th century. A jug identical to Figure 64.43 occurs with Middleborough kiln-style Fabric 13 (c 1175-1225) on the Angel Yard site and sherds with similar horizontal combed decoration occur in 13th-century contexts (eg Fig 218.9, Stratified Group 7, c 1225-1250/75) which accords well with its hand-made character.

Squat jugs with inturned or carinated rims occur from Period 3.1 (c 1150/1200-1250/75), but probably towards the end of this range as most of them occur in later periods. The inturned rim and broad, unusually plain, strap handle (Fig 65.49-50) are associated with wholly wheel-made jugs and commonly occur with neckless rimmed cooking pots suggesting production from c 1250/75 (eg Fig 218.7, Stratified Group 7).

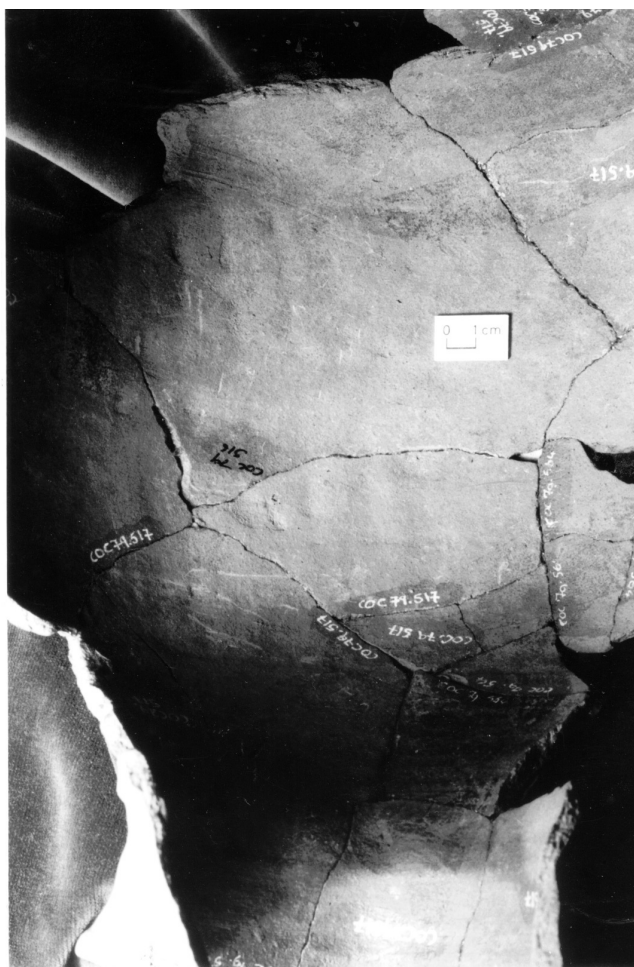

Fig 63 Medieval greyware: internal detail of rounded jug (no 41) showing evidence of composite manufacture.

Squat greyware jugs almost identical in form to Figure 65.49 occurred in a well at Bramford, Suffolk in association with a Mill Green-style polychrome baluster jug of *c* 1290-1325 (Erith 1972, fig 3.5 and fig 4.12 greywares; fig 4.7 Mill Green-style jug). This later type of wheel-made squat jug commonly lacks the ribbed neck of the earlier type and is generally much plainer and functional in appearance. The appearance of the inturned rim at Colchester was contemporary with or slightly earlier than its appearance in the Mill Green industry where it is typical of the period *c* 1270-1350 (Pearce *et al* 1982).

Very broad strap handles (up to 70 mm across), either plain or with a central thumbed strip (eg Fig 65.47-50), occur mostly in late contexts (Periods 3.2-4.2/5). These and other fragments suggest an increase in the number of large, perhaps very large, jugs (eg Fig 65.47) similar to a large squat/rounded late 13th- to 14th-century jug from Danbury (Drury & Pratt 1975, fig 57.A9). Some of these may be cisterns (see below).

The third Fabric 20 jug form that can be distinguished is the pear-shaped or small rounded jug (Fig 65.51-52). This is probably the least common of the three forms and perhaps the latest. The only definite examples are wheel-made and have thumbed bases. The sharply inturned rim of Figure 65.51, together with its method of manufacture, suggests it

was produced after *c* 1250/75 and was contemporary with the later, plainer type of squat jug. The form of Figure 65.51 in particular is similar, though not exactly matched by, jugs in Colchester-type and Mill Green ware. The unique vertical combed decoration on Figure 65.52 may be in imitation of combing on either Mill Green or Hedingham ware jugs.

Baluster-shaped and conical jugs do not occur in Fabric 20 (but see 'bottles' below).

Rim diameters of all jug types range from 75 to 160 mm with most falling between 100 and 130 mm. The most common rim type, with many slight variations, is the thickened flat-topped rim (Type B2, 37% EVEs, eg Fig 64.41 & Fig 65.45-47). These occur in all periods but are rather more common in the 13th century. Plain everted rims (Type A1A, 8%) are commonly associated with the ribbed necks of squat jugs (Fig 64.42-43). Inturned or carinated rims account for 18% of jug rims (Type G1, Fig 65.49-51), while rims with a pointed external bead comprise 12% (Type B5, Fig 65.48). The remaining types and variants of the above types are not numerically important. Apart from the inturned rim (after *c* 1250/75), most rim types on their own are of very limited use for dating.

Jugs, generally, are more often decorated than cooking pots. Thirty per cent of jugs (by EVEs) are decorated (or 47% by weight), although most of this decoration is confined to the handle where a variety of stabbed, thumb-ed and applied decoration may occur, either singly or in combination (Fig 64.40-43 & Fig 65.44-48). Jug handles are predominantly oval in section, followed by broad elliptical strap handles. Rarer types have a central furrow (generally late) or two furrows. Rod handles are fairly uncommon.

Decoration on the jug body is less common and more restrained. Ribbed necks, previously mentioned, are fairly common. Bands of horizontal combing (Fig 64.43) occur on a few examples and vertical combing on a single example (Fig 65.52). The pair of thumb-ed or finger-impressed indentations on the rim of Figure 64.40 and below the pouring-lip of Figure 64.41 are unique to these vessels, but mirror similar decoration found on cooking pots (Fig 58.6, 4 and 9).

#### Miscellaneous forms

Minor forms, normally represented by less than five examples, and a few oddities, are dealt with below.

#### Storage jars (Fabric 13T or 20: Fig 60.22-23)

Fragments of at least three large storage jars were found. Two ?lid-seated examples, including Figure 60.23, were found on the same site in the remains of a 12th-century stone building (Building 28, see p 5). Figure 60.23 is very deeply thumb-ed on the outside and on the inner ledge (which may be applied), and has deeply-stamped circles along the top of the rim. It bears traces of mortar from its re-use as rubble in a 17th-century fireplace. All have a very hard and very coarse grey sandy fabric, but Figure 60.23, unusually, is also tempered with moderate, very coarse inclusions of fossiliferous limestone (including cockle). A very similar, much abraded example (LWC GF196 sealing a Period 2.3 pit) was sealed by the foundation trench of a wall for one of the rooms of the 12th-century building; this particular room was probably constructed towards the end of the

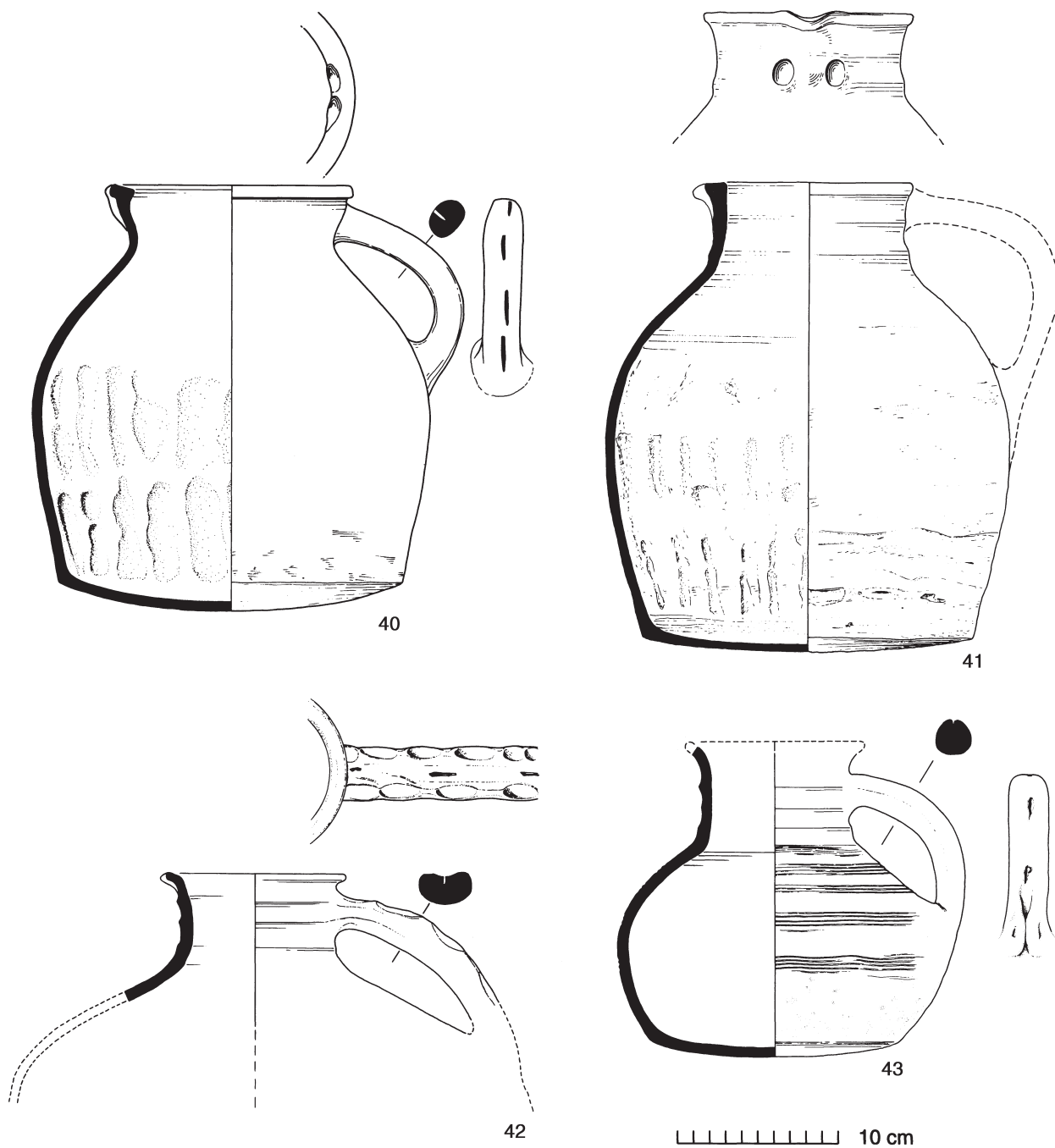

Fig 64 Medieval greyware: rounded jugs (nos 40-41); squat jugs (nos 42-43). 1:4.

date range of c 1125-50. This example lacks the stamped circles of Figure 60.23 and retains part of a horizontal thumbstrip on its shoulder. It closely resembles an example found during earlier excavations at the castle (Cunningham 1982a, fig 27.28). These lid-seated jars are very like a large storage jar from the kilns at Hedingham now displayed in Colchester Museum (see p 44), and are also quite similar to the storage jars produced at the Middleborough kilns (see Fig 37.93-98). Figure 60.22 has a large thickened flat-topped rim with traces of horizontal thumbstrip on the exterior.

These large storage jars in a hard, coarse grey fabric, superficially akin to Fabric 20, are something of a misfit and may not be part of the regular Fabric 20 'industry' at all. The forms suggest a 12th- to early 13th-century dating, but the only usefully stratified example comes from a context of c 1150 or thereabouts. This would predate the Mile End kilns and even the Middleborough Fabric 13 kilns (c 1175-1225). However, as the same set of contexts under Building 28 also produced the earliest glazed Hedingham fine ware (Fabric 22), it is not inconceivable that two of the three storage jars could be examples of Hedingham coarseware

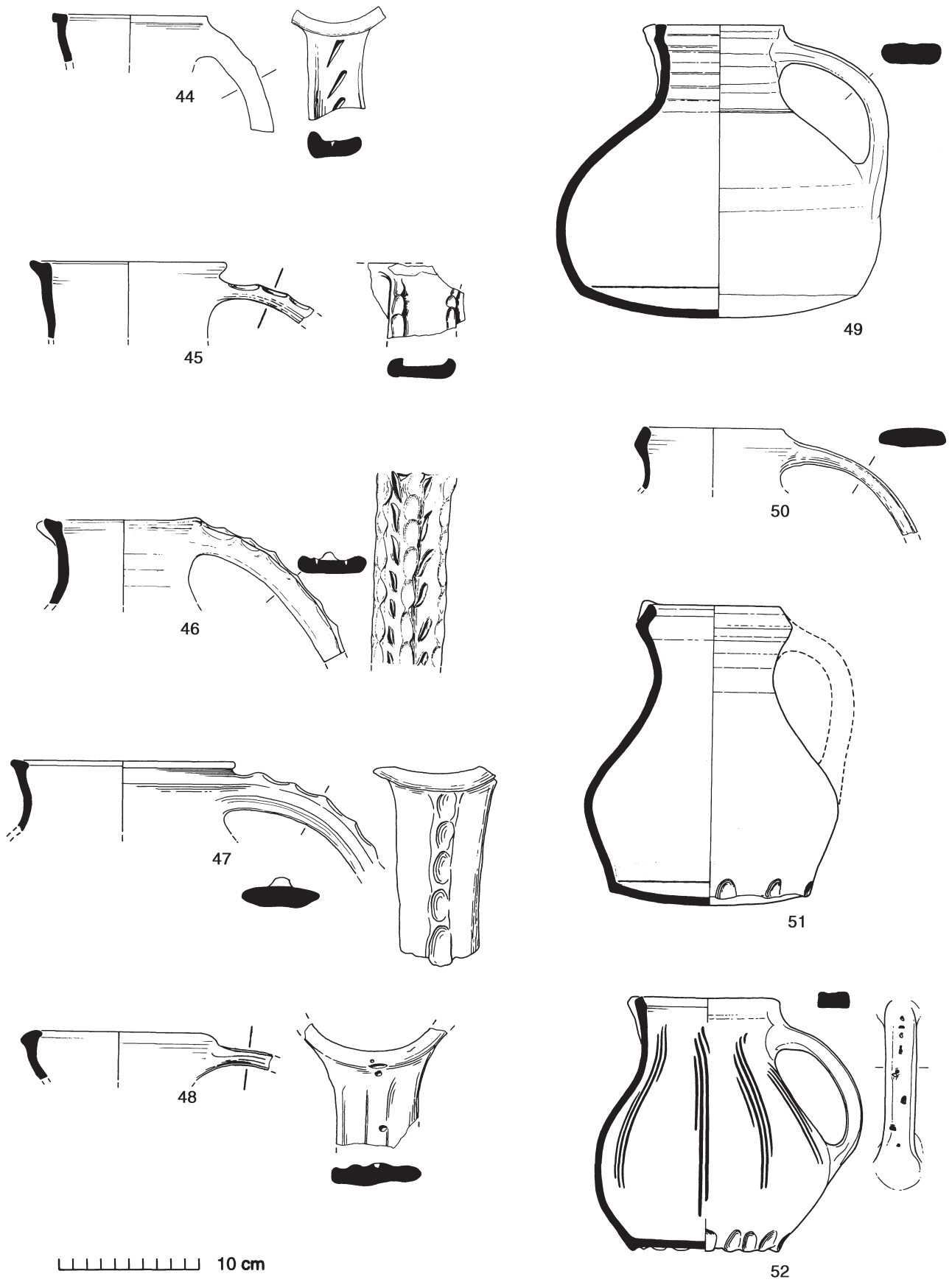

Fig 65 Medieval greyware: squat jugs (nos 44-50); pear-shaped jugs (nos 51-52). 1:4.

(Fabric 20D). The third example (Fig 60.23), however, with its limestone inclusions, may be a regional import, as fossiliferous limestone does not outcrop in Essex.

#### *Skillets* (Fig 60.24-26)

Basically these are small cooking pots with an added side handle. The three illustrated examples all come from the same context on the Cups Hotel site (CPS L48, Period 3.2) which also produced two Mill Green ware jugs (c 1270-1350), and a coin lost c 1250-79 (CAR 4, 66). All three are wheel-thrown. The rim of Figure 60.24 may be designed to take a lid. The complete vessels may originally have had pouring-lips. Figure 60.25 and 26 are sooted from use.

#### *Frying pan* (Fig 62.39)

Possibly unique. This example with horizontal flanged rim and a tongue-like side handle is from the Lion Walk ditch sequence where it was associated with a coin lost c 1350-75 (CAR 4, 65).

#### *Cisterns* (Fig 66.53-56)

Cistern rims are distinguished from jug rims by their greater diameter. This is, however, a rather arbitrary distinction as some large 'jugs' in this fabric may actually be cisterns, as is sometimes the case with Colchester-type ware. Unless the vessel profile is sufficiently complete, however, and includes an attached bung-hole, the distinction cannot easily be made. Bung-holes may be plain, flattish or tubular (Fig 66.55), or faceted (Fig 66.56, Period 4.1). Figure 66.55, if it is really a cistern bung-hole, is the earliest example, and was found in association with a coin lost c 1250-79 (CAR 4, 66) and some Mill Green jugs (c 1270-1350; the skillets described above). Fabric 20 cisterns could therefore date from the late 13th century though most are likely to be 14th century.

#### *Bottles or measures* (Fig 66.57; Fig 67, left)

At least two of these are known from the excavations, and there are three others in the Colchester Museum, including one from Colchester's port at the Hythe (CM 1322.1907). All are wheel-thrown and lack evidence of handles. A complete example (unmarked, labelled 155) has an externally thickened flat-topped rim and one other example, possibly not found at Colchester, is of baluster shape (CM 541.63). These cylindrical vessels have flat bases showing wire marks where they were removed from the wheel. A base fragment, identical in shape and size to the illustrated vessel, was found in a Period 3.2 context (COC L115). Similar vessels at London usually provided with a handle are described as conical drinking jugs (Pearce *et al* 1985, fig 66), whereas handleless baluster-shaped vessels are described as bottles (*ibid*, fig 64.298-304). These London forms date around the mid 13th to the mid 14th century.

#### *?Industrial vessel* (Fig 66.58)

This rim is not comparable to known jug rims in this fabric. It resembles industrial vessels known as cucurbits which were used in distilling. This is a form more commonly found in

glass, although several pottery examples are known (eg Moorhouse 1972, fig 28.5 & 11). The context of Figure 66.58 produced 13th- to 14th-century wares no later than c 1350.

#### *Dripping pans* (Fig 66.59)

The illustrated example has traces of a handle scar and is sooted. The top of the rim is decorated with an incised wavy line. Other fragments include a flat base with a straight edge, which is probably residual in its Period 4.2 context (LWC HF15). A larger fragment from the Osborne Street (1988) excavation has a low flaring wall ending in a thickened rim with a long, tongue-like side handle. Most examples are probably 14th century, but there is no useful dating evidence.

#### *?Water sprinkler* (Fig 66.60)

This interpretation is open to question. The object, of hollow mushroom-like form with a cylindrical 'neck', is competently wheel-made. There is no trace of an air hole which would normally be found on the top, although this may have existed further down the neck. From a Period 3.1 context.

#### *Curfews or fire-covers* (Fig 66.61-62)

Only two examples are known. These are basically large, inverted, hand-made bowls. The rim of Figure 66.61, from the Angel Yard (1986-7) site, is possibly wheel-finished. Both the flanged rim of the tubular aperture and the lower shoulder of the vessel have rows of stabbed decoration made with a sub-square pointed implement. On the upper shoulder, there is a single incised wavy line. The inside of the vessel is sooted from its use over a fire. Both the open-textured character of the fabric (not far removed from Fabric 13T) and the presence of squared cooking pot rims from associated contexts, suggest an early 13th-century date for this unusual vessel. Curfews of this form, with a tubular aperture on top, are very uncommon. The only parallels known to the writer are with local medieval curfews at Norwich (Jennings 1981, fig 13.269-72).

The second curfew (Fig 66.62) also occurs in a fabric not greatly dissimilar to Fabric 13T but with moderate inclusions of very coarse shell or fossiliferous limestone, suggesting a non-local source. Below the shoulder angle, vertical ridged applied strips give a fluted effect until thumb impressions commence 40 mm below the angle. The horizontal strip once covering the angle has become detached. It is not impossible that this is the base of an unusual storage jar, but internal sooting suggests it is more likely to be a curfew.

At least one Fabric 20 bowl is sooted internally and could also have served as a curfew (not illustrated).

#### *Lids* (Fig 66.63)

These are wheel-thrown and plain with simple rims, sometimes thickened and slightly bevelled, which helps distinguish them from otherwise identical lids in Roman coarse greyware.

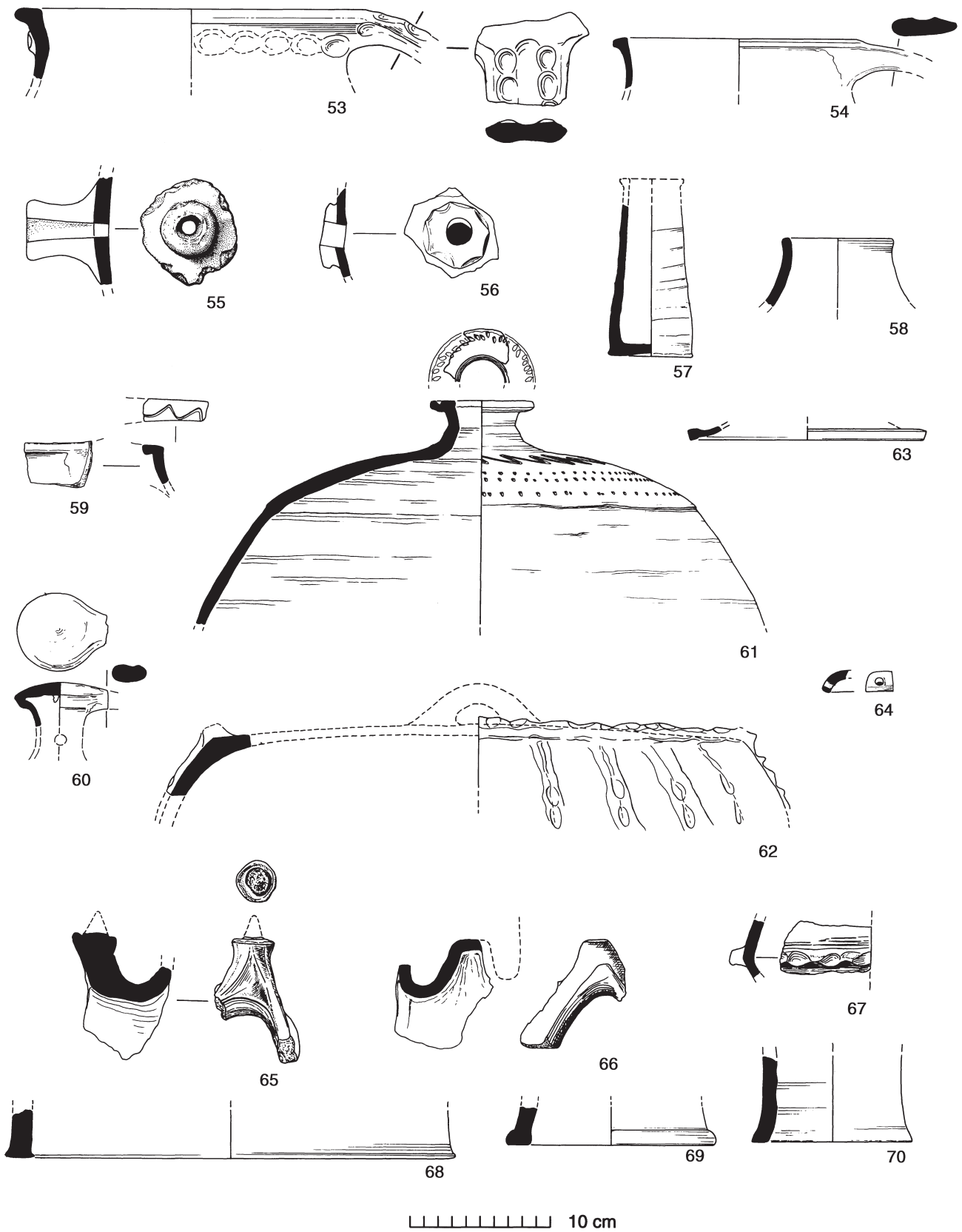

Fig 66 Medieval greyware: miscellaneous forms — cisterns (nos 53-56); bottle or measure (no 57); ?industrial vessel (no 58); dripping pan (no 59); ?water sprinkler (no 60); curfews (nos 61-62); lid (no 63); pierced rim (no 64); louvers (nos 65-67); chimney pots or drain pipes (nos 68-70). 1:4.



Fig 67 Medieval greyware: group of miscellaneous forms c 1200-1350 ; height of tallest jug, back row, 268 mm.

#### *Perforated sherds and secondary use* (Fig 66.64)

A rim (Fig 66.64, Period 4.1) and a small number of sherds have been perforated either before or after firing. The purpose of these solitary perforations is unknown but may have allowed suspension of the vessel. One or two sherds have been filed to a roughly circular shape for use as gaming counters (MID CL13, late 14th century, not illustrated; CAR 5, 45).

#### *Louvers* (Fig 66.65-67)

A few unglazed louver fragments occur in Fabric 20. These show no indication of being accidentally reduced examples of Colchester-type ware, which is the normal fabric for louvers. At least two separate louvers are represented: one by Figure 66.65-66 from the same context on Long Wyre Street and the second by Figure 66.67 from Balcerne Lane. Figure 66.65-66, almost certainly from the same louver, probably represent different tiers of the same vessel. These are useful in showing the presence of three types of finials or knobs in association, the 'sombbrero' or 'toadstool' finial of Figure 66.65, and the plain nib and hollow truncated cone of Figure 66.66. All these finial types occur on Colchester-type ware louvers. Figure 66.67, which is probably a louver, has a horizontal applied and thumbled cordon similar to Colchester-type ware louvers, but the carinated form and the cut vertical slot or aperture of this vessel are unusual.

Figure 66.65-66 occur in a Period 3/4.1 context (c 1200-1500) but, as they occur with a louver fragment in London-type ware (Fig 43.6), they might be similarly dated to the late 13th or earlier 14th century. Figure 66.67 has no useful direct associations but must be derived from the medieval town ditch at Balcerne Lane which produced a range of late 13th- and 14th-century wares.

#### *Chimney pots or drain-pipes* (Fig 66.68-70)

Chimney pots were produced at the kilns at Mile End, Colchester during the 13th century (Drury & Petchey 1975, fig 11.61-4). They are represented from the town by only a few miscellaneous fragments, some of which could be from drainpipes. Figure 66.70 has traces of mortar, and was

associated with a coin of c 1300-10, lost before c 1350 (CAR 4, 67), though probably residual in its Period 4.1 context. The large diameter of Figure 66.68 suggests perhaps that this is from the base of a louver rather than a chimney pot (see above). A large chimney coping in Fabric 20 (or ?13T) has previously been published from the Middleborough site (CAR 3, fig 188).

#### **Summary of principal developments in Fabric 20** [Fig 68]

Evidence from Colchester, supported by evidence available from elsewhere in Essex, suggests that the sandy coarse-ware industries underwent significant changes around the middle of the 13th century. The most important change was the shift from hand-made (or semi hand-made) to fully wheel-turned vessels. This event seems largely to coincide with the appearance of new rim-types and other features on traditional coarse-ware forms: cooking pots, jugs and bowls. A general improvement in fabric quality at around this time also suggests improvements in clay preparation and firing conditions. The reasons for these changes are not fully understood and they probably occurred at slightly different times across the county. At Colchester, these changes seem to have occurred around 1250-75 and probably earlier rather than later in this range. The way in which traditional vessel forms were affected is summarised below. For convenience, these have been divided into 'Group A' and 'Group B' forms.

#### *Group A forms* (c 1175-1250/75)

##### *Cooking pots*

Hand-made body, wheel-turned or wheel-finished rim, and shoulder possibly separately made and subsequently attached to body. Rims commonly squared or externally thickened and flat-topped with a short upright neck. Internal rim angle commonly a right-angle or greater. Relatively 'open' textured, low-fired fabric.



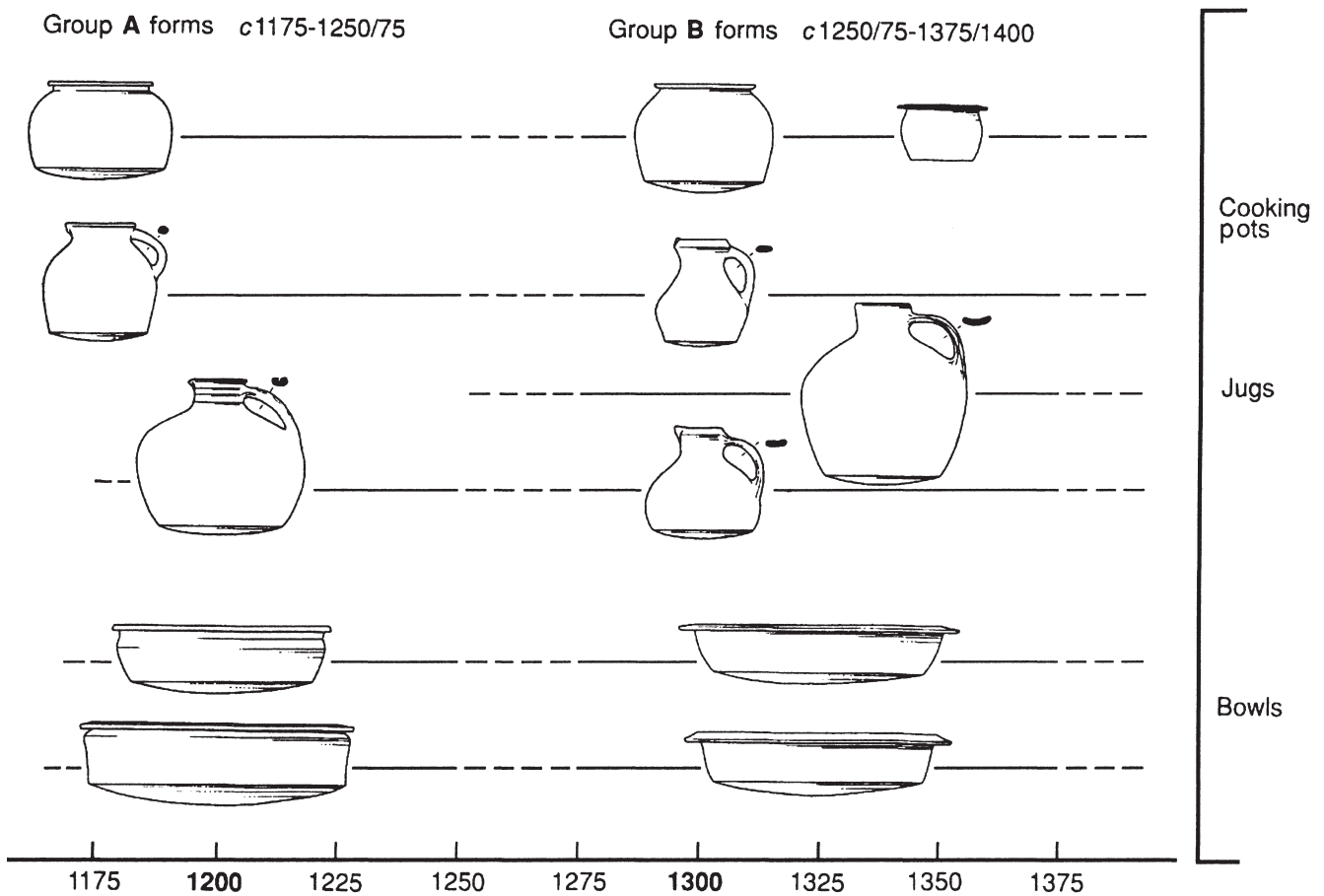

Fig 68 Medieval greyware: diagram showing the estimated time span of the main forms at Colchester.

#### Jugs

Manufacture and fabric as above. Rounded and squat forms usually with ribbed cylindrical neck and simple everted or thickened flat-topped rims. Decoration, particularly on handle, fairly common.

#### Bowls

Probably hand-made. Shouldered forms with squared or thickened rims similar to cooking pots. Some decorated.

#### Group B forms (c 1250/75-1375/1400)

##### Cooking pots

Fully wheel-made. Generally shoulderless with blocked neckless rims. Sharp internal rim angle, commonly 45-50 degrees. Harder, denser, more highly-fired fabric.

##### Jugs

Manufacture and fabric as above. Squat and pear-shaped forms with inturned or carinated rims. Usually plain. Some squat jugs very large.

#### Bowls

Manufacture and fabric as above. Shoulderless, with steep flaring sides and commonly with pronounced horizontal or down-turned flanged rims. Usually plain.

#### Colchester-type ware (Fabric 21A)

[Figs 69-120 & 247; Pls 1-6]  
 Weight: 419.110 kg.  
 Number of sherds: 13,880\*  
 EVEs: 145.14\*

#### Introduction

Fabric 21 embraces all sandy orange wares of medieval date and presumed Essex origin. Fabric 21A is a coarser variant of this fabric found in the Colchester area, but for the purposes of this study the term 'Colchester-type ware' will be used to refer both to the 'classic' orange quartz fabric

as defined by Carol Cunningham (1982a, 365 & 367), and the less distinctive orange sandy wares from the Colchester excavations, since the majority of these are also likely to be of local origin. Some non-local Essex or East Anglian orange sandy wares are almost certainly present in this sample but if so, the quantities present are probably quite small and there is no obvious way of distinguishing them short of scientific analysis.

The use of Carol Cunningham's original (but provisional) labels 'Colchester ware' and 'Colchester slip-painted ware' (later coded Fabric 21A and 21B respectively) has been avoided in this study as these can present some difficulties. Although they correspond closely to the division into early and late Colchester-type ware presented below, the reliance on the presence of slip as a means of classification is limiting, particularly as most Colchester-type ware is unslipped. Furthermore, it is now realised that 'slip painting' was not an exclusive feature of the later industry, but was present to some degree from the earliest days of production.

After early medieval sandy ware (Fabric 13), Colchester-type ware is the commonest medieval fabric found on excavations in Colchester. Although it was in production for around three and a half centuries, from the early 13th to the mid 16th century, it only achieved local predominance in the last century and a half of production so that most excavated pieces tend to be of late medieval date. Both the fabric and, to a lesser degree, the forms, exhibit a high degree of conservatism. Consequently the dating of isolated and undiagnostic sherds can be problematical. Nevertheless some development in fabric characteristics can be discerned.

### Fabric

The parent clay used for Colchester-type ware is almost certainly the London Clay which mostly outcrops to the north of the town, where it is often interspersed with sands and gravels of glacial origin (see Appendix 2, p 364). Locally produced medieval roof tiles have a visibly very similar, though coarser, fabric. Thin-sectioning of a reduced sherd of Colchester-type ware from the Great Horkesley kiln-site (see below) showed the matrix to contain numerous vesicles. These are believed to be due to the presence of finely divided organic matter and are typical of both the Oxford and London Clays (Alan Vince, pers comm). Colchester-type ware resembles other basic coarse-ware fabrics made from London Clay. It is visually very similar, for example, to Tyler Hill ware from kilns to the north of Canterbury in Kent, and like the latter may also have been deliberately tempered by the addition of sand derived from brickearth deposits (Streeten 1982). Confusion between the two wares, however, is unlikely to arise, as Colchester-type ware is generally sandier and more oxidised than the Kent fabric, and there are notable form/decoration differences.

The fabric descriptions below were obtained from the examination of large numbers of sherds both with the naked eye and by (x20) microscopic examination. In addition to these, four samples thin-sectioned by Alan Vince are also described.

#### Early Colchester-type ware (c 1200-1375/1400)

Fabric: This is hard and bright orange, normally with a reduced grey core and abundant medium-coarse sub-

rounded quartz, commonly transparent or milky-white and translucent. The quartz, sandy nature of the fabric is worth stressing as a prime factor in the identification of this fabric. Other inclusions are: moderate coarse red iron oxide, rare calcareous specks (not detected in thin-section), rare very coarse inclusions of quartz and flint, and occasional fine brown mica in the matrix (not detected in thin-section). The unglazed surface has a fairly rough feel and pimply appearance. Softer, duller, underfired examples may occur as do some completely reduced, overfired examples.

A jug sherd of c 1200-50 with Rouen-style decoration (Fig 82.50) had the following composition seen in thin-section: abundant rounded quartz, mainly with polycrystalline grains, up to 0.5 mm across; sparse angular quartz up to 0.2 mm; sparse rounded chert up to 0.5 mm; and moderate red and black 'clay pellets' up to 1.0 mm. The clay matrix of this sample contained sparse quartz, less than 0.1 mm, and was optically isotropic.

Slip and glaze: Overall or partial external cream slip, fairly thick. Wiped on in semi-liquid form in broad random strokes. Less frequently a pale orange-pink slip is used. Lead particles in the glaze may etch into the underlying slip to produce a pitted surface and a streaky oily effect over wiping marks. Linear decoration employs a thick slip applied in a semi-plastic state to create lines in low surface relief. Slipped areas are normally covered with a green copper-flecked glaze, while plain vessels have a clear glaze which may be greenish if the fabric is reduced. Pellets of raw lead are occasionally found embedded in the surface.

#### Late Colchester-type ware (c 1400/25-1550)

Fabric: Basically as above. Some general improvement in quality giving a harder, more even fabric, with an increasingly 'post-medieval' character. The unglazed external surface is frequently reduced, perhaps deliberately to contrast with the slip decoration (28% of the early 15th-century Stratified Group 10 had reduced surfaces).

A sample from a slip-decorated cistern (Fig 84.74) from the 15th-century kiln-site at Magdalen Street (see below) was thin-sectioned along with a slip-decorated sample (late 14th to 15th century) from the Great Horkesley kiln-site. These proved to be indistinguishable except for the fine vesiculation and slightly larger 'clay pellets' in the latter sample. Both samples were reduced and possibly over-fired. Both had the following composition: moderate rounded quartz up to 0.5 mm across in which the grains were monocrystalline, sparse angular quartz up to 0.2 mm, sparse rounded chert and flint up to 0.5 mm, and sparse rounded black 'clay pellets' up to 0.5 mm (1.0 mm at GH). The clay matrix contained sparse quartz less than 0.1 mm, and was optically isotropic.

A fourth sample from a jug with typical 'late style' (15th-16th century) slip dashes on the rim was also thin-sectioned. This was from the Angel Yard site (40.86 (990)) and was in an oxidised fabric with the following composition: moderate rounded polycrystalline quartz grains up to 1.0 mm across, sparse quartz and moderate white mica less than 0.1 mm, and anisotropic matrix. This sample was the only sample to include mica in the clay matrix. It was also unusual in having a coarser grain size and no chert or flint fraction within the sand (although other 'late style' specimens do seem to contain odd grains of chert/flint). The presence of

mica may be significant, but, as it was the only sample to have been relatively low-fired (proven by the optically anisotropic matrix), it is quite possible that muscovite mica was present in the three other thin-sectioned samples but has been altered by firing. Further samples would need to be examined in thin-section before the differences seen in the 'late style' sample can be accepted as evidence for a different source rather than different firing conditions (Alan Vince, pers comm).

A finer, more silty, micaceous fabric is sometimes used for late plain forms such as cups, thin-walled baluster jugs (eg Fig 74.20-23), some chafing dishes (Fig 102.207), and hammer-head rimmed bowls (Fig 97.167-172), although most of these forms also occur in the typically coarser fabric. Whether these finer, more micaceous fabrics represent a non-local source (?perhaps the Hedingham/Halstead/Braintree area), or a late and transitional Colchester-type fabric, or both, remains uncertain.

Slip and glaze: These are sparingly used in contrast to the earlier fabric. The overall use of slip virtually disappears as does the use of green copper-flecked glaze. Exuberant but stylised linear slip painting, using a very thin slip, replaces the thick all over slip of the earlier fabric. Many slip-painted vessels, particularly jugs and jars, are completely unglazed or receive just a token splash or bib of clear glaze.

## Sources

### a) Essex and East Anglian redwares

Colchester-type ware is part of the wider medieval tradition variously known as 'Essex redwares' or 'East Anglian redwares' (Hurst 1961b, 255 & 257; Rackham 1972, pl 4), many of which are slip painted and generally similar in appearance. Neither of these labels is closely defined. Nor is the late medieval tradition of exuberant white slip painting on a red background confined to East Anglia. Similar redwares, for example, were produced at Cheam in Surrey (Orton 1979). Recent neutron activation analysis of Essex redware samples reveals that, in spite of their visual similarities, the different production sources can, at least chemically, be distinguished one from another (see Appendix 3). Ultimately this may be the only secure way of distinguishing between them.

Despite the wide distribution and production area of East Anglian redwares, very few kiln-sites have been located or published, and even though the bulk of such wares at Colchester is likely to be of local manufacture, some quantity of non-local redwares is likely to be present. Almost nothing is known of the production of these wares in adjoining Suffolk, although jugs decorated with white slip are known to have been produced at Hollesley, about 32 miles north-east of Colchester, where there is documentary evidence for pottery production in the later 13th century (McCarthy & Brooks 1988, 272).

Several of the Essex sites (or their environs) listed below also produced redwares in the post-medieval period (Fabric 40: see map of production sites, Fig 129).

In Essex, related or at least similar medieval redwares, sometimes with slip decoration, were produced at Harlow from perhaps the 13th century (Walker 1991d, 109). This

has iron-stained sand, chalk flecks and other characteristics which should allow it to be distinguished from similar wares. Slip-painted wasters from an unlocated 15th-century kiln have also been found at the southern end of Potter Street, Harlow (Walter Davey, pers comm). Though mostly reduced, perhaps over-fired, this coarse late medieval Harlow ware is very similar in appearance to late Colchester-type ware and includes a similar range of vessel forms, cisterns, squat jugs and bowls. Slip-painted decoration at Harlow does not, however, include Colchester-style slip dashes on the rim.

A fairly micaceous slip-painted redware was produced at Blackmore End near Sible Hedingham (see p 90), but almost nothing is known about the later industries in this northern part of the county.

Oxidised and reduced jugs with white slip decoration and green or clear glaze were found at the decorated-tile-making site at Danbury, south-east of Chelmsford, and appear to be of late 13th- or early 14th-century date (Drury & Pratt 1975, 127-32, fabrics C, G and H). Although it is not stated in the excavation report, some of the Danbury pottery could have been produced there, or perhaps nearby, as there are some documentary references to potters there (McCarthy & Brooks 1988, 302). The source of the plain or slip-decorated Fabric 21 occurring in late medieval contexts at Chelmsford is unknown but thought to be in the Ingatestone/Stock area (Cunningham 1985, 1).

In the south of the county, sandy redwares with white slip decoration are known from a production site at South Woodham Ferrers which appears to date to the late 14th to early 15th century (Buckley & Eddy 1979). This included sherds with debased Rouen-style decoration in white slip and handles with white slip stripes (*ibid*, fig 32.38-9 and 26 respectively), features shared by the Mill Green and Colchester-type industries. To a certain extent, this brief survey of Essex or East Anglian redwares also embraces the better-known Mill Green industry of central Essex (Pearce *et al* 1982), and to some extent the Rayleigh production site in south Essex (Walker 1990b). Although these last two closely-related industries produced pottery with slip-painted designs similar to Colchester-type ware, the fineness of these fabrics sets them apart from the coarser range of redwares to which Colchester-type ware belongs.

The sandy often slip-painted redwares found in the south-west of the county at Waltham Abbey are thought to have been locally produced particularly in view of references to local potters in the early 14th century (fabric J2; Huggins 1976, 102-3).

### b) Colchester-type ware

It is certain that the bulk of the ware found at Colchester was locally produced. Wasters or 'seconds' of the fabric occur in deposits spanning virtually every stage of its long life span testifying to the presence of undiscovered local kilns. Two particular groups of wasters point convincingly to the presence of kilns in the vicinity.

The first group came from three locations near The Rookery, Great Horkeley, 3.5 miles north-west of the town (Drury & Petchey 1975, 54-9, fig 1). Material from the first location (site 4), discovered in 1948, was not methodically recovered. The other two locations (sites 2 & 3) were investigated in 1973, prior to the laying of a gas pipeline. The majority of waster material from Great Horkeley consisted

of jugs and cooking pots in medieval greyware (Fabric 20). These displayed late characteristics, almost certainly 14th century. Occurring in the same pits as these greywares on site 3 was a much smaller number of sherds with a cream slip or slip decoration under a green glaze, and on site 4 with slip decoration and a sparse clear glaze. Re-examination of this material now shows that these slipped and green glazed sherds are reduced wasters of Colchester-type ware. The similarity of the late greyware fabric with the reduced Colchester-type ware fabric serves to underline that these two fabrics are essentially the same but differ deliberately in their conditions of firing, decoration and form. Diagnostic sherds of Colchester-type ware from Great Horkelesley were rare, but include a jug with plain rim and five faceted cistern bung-holes (*ibid*, fig 13.70 & 81), a characteristic collared rim (*ibid*, fig 13.82), and an equally characteristic 'cornice' rim (not illustrated). Many more sherds, including an apparent waster with sgraffito decoration (Fig 113.286), came from the surrounding topsoil. Pottery in the Colchester Museum from site 4 (CM OS3.1968) included overfired/reduced waster fragments from several jugs. These have strap handles of elliptical or flattish, shallow-furrowed section. A central band of thin cream slip runs the length of the handle and appears to link horizontal bands at the rim and the girth. One strap handle has slip-painted furrows exactly as Figure 78.32, and all these handles come from similar wide-bodied jugs. The decorative scheme and sparse clear glaze indicate a late 14th-/early 15th-century date as opposed to the 14th-century date suggested for the green glazed sherds from sites 2 and 3. The Great Horkelesley wasters suggest that early Colchester ware may have been produced alongside Fabric 20 in nearby kilns, perhaps in alternating phases of reduction or oxidising firings or else in a kiln set aside for oxidised wares.

The location at Great Horkelesley was a natural one for pottery production. Kilns producing Fabric 20 in the late 12th and 13th centuries lay just over a mile further south at Mile End (*ibid*) and were undoubtedly exploiting the same deposits of London Clay, sands and gravel that formed much of these parishes, and fuel would have been available from Horkelesley Heath nearby. Documentary references to potters in the area are known from the late 13th century (see Appendix 2, p 367). There are also two late medieval documentary references that testify to pottery production at Great Horkelesley, and suggest that, in its time, it may have been an industry of some size and perhaps of more than purely local significance. The first of these is a reference in 1405 in the Court Rolls to a '*John Popelote, potter of Horkelesgh*'. The second reference is a record of payment in 1466 by Sir John Howard, '*to one of the potters of Horkelesley 4s 6d to pay himself and his fellows for XI dozen pots*' (see Appendix 2, p 367). The pots may have been destined for the Howard family seat at Stoke-by-Nayland (Suffolk), three miles north, or they could even have been destined for the new ship Howard was constructing that year at Dunwich, Suffolk (Hudson Turner 1841, 88).

A second, and more impressive, collection of pottery wasters was recovered in 1907 from the yard of Messrs Groom, Daniels & Co on the corner of Magdalen Street and Military Road (Fig 1). The location, outside of the town wall, a little south of the South Gate and the south-east corner of the town wall, mirrors that of the early medieval kilns at Middleborough north-west of the town. Vessels reconstructed from the fragments include two deep straight-sided bowls with

simple horizontal flanged rims (since lost), four wide-bodied, slip-painted jugs and a small cooking pot (CMR 1908, 18-19 with plate). The jugs and cooking pot are published (Cunningham 1982a, fig 29.46-50). One jug (*ibid*, fig 29.46), severely warped and split, was an obvious waster. Excavations in 1974, at 11 Magdalen Street (CAR 6, 341-4) nearby, produced the highest concentration of Colchester-type ware wasters from any of the 1971-85 sites. Most of the wasters came from perhaps as few as half-a-dozen vessels, identical in character and form to the earlier discoveries. The reduced and warped jug-shaped cistern (Fig 84.74) is identical in form to the jugs mentioned above. These Magdalen Street jugs and cisterns are almost certainly the work of a single potter since they share certain idiosyncratic traits, such as a plain rim with a rib below, a deep and clumsily scored groove on the neck and a scored line parallel to the rather casually painted slip lines, almost certainly caused by finger-painting with badly kept fingernails. Most of the wasters came from a single pit (MSC F53 Period 4) and an underlying layer (MSC L6) which contained an Anglo-Gallic counter datable no closer than late medieval (CAR 4, 83). The rather simple jug rims, broad bibs of glaze and somewhat non-standard style of flat slip painting, coupled with the simplicity of the bowl rims, suggest a date around the middle of 15th century.

Potters operating in Magdalen Street in the 15th century would have had access to water from several wells in the south-east of the town, including Childwell in Magdalen Street itself (Morant 1748, 1, 1). Colchester's Court Rolls contain many references to the activities of tilers, tile kilns and clay-digging in the late 14th and early 15th century east of the High Street (see Appendix 2, p 366). Magdalen Street lies only about 450 m away, slightly to the south-west of this area, which may similarly have provided suitable potting clay, although its collection from this area was evidently illegal.

Although there are odd splashes or dribbles of white slip on the rims of wasters from Magdalen Street (Fig 84.74), neither from this site nor Great Horkelesley are there unequivocal examples of 'late style' slip dashes on the rim. This might suggest that vessels with slip-dashed rims, so common on late Colchester-type ware, were produced at some other location (as the thin-sections seem to hint) or alternatively the sample from both production sites is too small and the slip-dashed rims remain to be found there. Magdalen Street may have been an offshoot of the older Great Horkelesley (Colchester-type) industry. Thin-sectioning of late medieval slipped sherds from both sites demonstrates that the fabric produced is petrologically indistinguishable (see above and Appendix 3). The source of the fine white clay used for slip decoration on Colchester-type ware is unknown but probably not from Essex. Small pockets of white clay are said to occur in the west of the county around Harlow and Latton and were exploited by the makers of Metropolitan slipware in the post-medieval period (Brears 1971, 181), but whether this source was exploited before this is not known.

**Dating and quantification (c 1200-1550)**

[Figs 69-70]

Improvements in kiln control and clay preparation towards the end of the 12th century brought about a transition, and eventually the decline, of the local early medieval sandy ware (Fabric 13). This transition produced first a reduced greyware (Fabric 20) and then, slightly later, the oxidised fabric now known as Colchester-type ware (Fabric 21A; see Fig 23). The greyware, greatly outnumbering the oxidised ware in this early period, continued to meet the demand for plain cooking pots, while the oxidised ware met a growing demand for glazed and decorated table wares, principally jugs.

Dating for both the start of the Colchester-type ware industry and its subsequent typological developments depends partly on the contextual/associated evidence and partly on stylistic comparison or affinities with better-dated pottery industries. The question of dating and typological/decorative affinities is very closely linked in the case of Colchester-type ware, as the contextual/associated evidence is rarely clear enough to allow individual pots to be closely dated. A more detailed discussion of affinities, however, will be reserved for later (see p 174-7), and only the essential dating information that they provide will be mentioned here.

The quantity of Colchester-type ware from contexts dated possibly to the late 12th century and definitely to the 13th and 14th centuries is quite small (Fig 69). In Period 3.2 (c 1250/75-1400), the ware comprised only 14.5% of the excavated assemblage. At this time, the greyware (Fabric 20) was the dominant ceramic type. After the demise of greyware production in the later 14th century, Colchester-type ware replaced it as the dominant ceramic type until Period 4.2 (c 1450-1550/80) when Colchester-type ware comprised 60% of all pottery used in the town.

Evidence for a pre-1200 start date for Colchester-type ware is slight but possible. Only two sherds from a single vessel have been assigned to Period 2.2-4 (c 1100-1200), but they almost certainly date towards the end of this range. The sherds were in an early medieval pit on Lion Walk Site D. This pit (LWC DF138) is at the bottom of the pre-building sequence on this site, and forms a continuation of the 12th-century pits and robber trenches on the adjoining Site G which were sealed after c 1150 by a stone house (Building 28). However, the building on Site D (Building 29, see pp 5-6), is later, probably after c 1250, and this ultimately seals the sequence begun by the pit DF138. Apart from the two early Colchester-type sherds, the pit contained only seven sherds of early medieval sandy ware (Fabric 13 & 13S, c 1025-1225), and this in turn was sealed by another pit containing a larger quantity of Fabric 13. The absence of medieval greyware (Fabric 20) from these pits is, however, curious, as it was probably in production by c 1175. Eight other sherds, apparently from the same distinctive early Colchester-type vessel in pit DF138, were scattered throughout Sites D and G. One sherd occurred in a Period 3 context (LWC GF156; c 1200-1400), also with Fabric 13 including a late 12th-/early 13th-century decorated cooking pot (Fig 24.32). The ten surviving early Colchester-type sherds come from the body of a thin-walled wide-bodied jug, smoothly finished outside but irregular inside showing that it was hand-made. The fabric is slightly atypical with dull orange-brown surfaces and a pale grey core. It is sandy

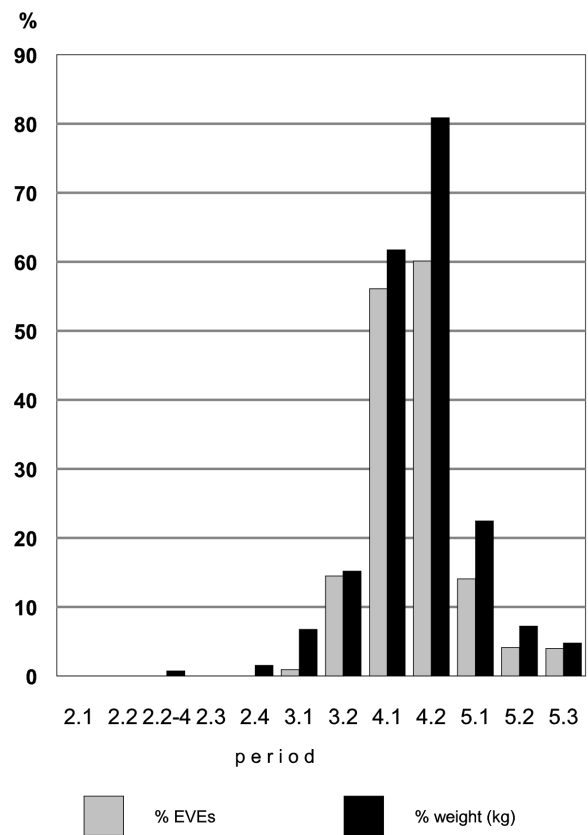

Fig 69 Colchester-type ware: bar chart showing percentages in stratified contexts (ceramic periods).

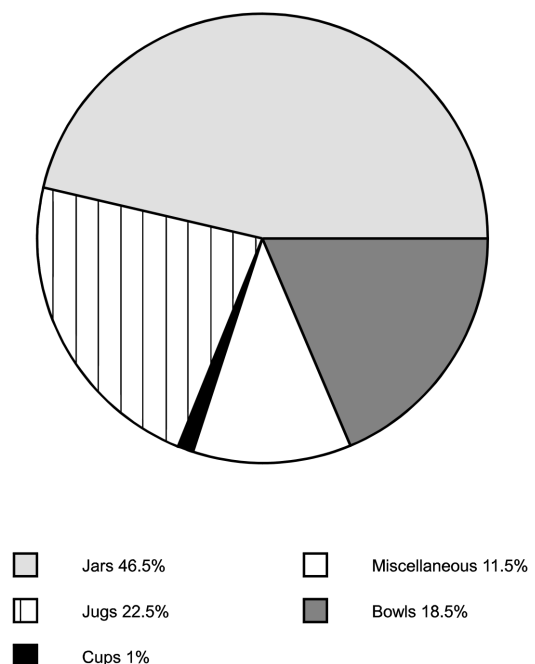

Fig 70 Colchester-type ware: pie chart showing vessel assemblage by EVEs.

and very hard with some quite coarse grains of quartz and rarer flint in a finer matrix containing some mica. The outside of the vessel has an all over thin orange-pink wash or slip which ends in a sharp, roughly horizontal line. A pitted, green, copper-flecked 'splash glaze' covers the slipped area exactly. An alternative identification has been investigated but, as it is more like Colchester-type ware than any other fabric, it seems likely that this identification is correct and that its atypical characteristics are a feature of its early date. Neutron activation analysis of this vessel also bears out this identification (see Appendix 3, 'test pieces').

Only eight body sherds of Colchester-type ware occur in Period 2.4 (c 1150-1200), again almost certainly at the end of this range. All the sherds associated with the early occupation of Building 28 on Lion Walk Site G are plain or have a reduced greenish glaze. These are in some cases associated with Hedingham ware and Fabrics 13 and 20, but the Colchester-type assemblage is not very informative. A single white-slipped sherd from the shoulder of a jug occurred in a layer in the Lion Walk ditch sequence assigned to c 1150-1200 (LWC NF2103; Stratified Group 4). The sherd has a similar fabric to the atypical vessel from Lion Walk D and G described above. The outside slipped surface is covered with a clear glaze with some green flecks (see Appendix 3, 'test pieces').

Three sherds of Colchester-type ware, including a thumbled baluster jug base, were found in the debris of the Fabric 13 kilns at Middleborough for which a date of c 1175-1225 has been proposed. However, these could be intrusive as one sherd has late-looking slip painting. The absence of Colchester-type ware from Stratified Group 7 (c 1225-1250/75) is curious, but several hard-fired oxidised sherds identified as Fabric 13 could in fact be unglazed examples of the former, and Colchester-type ware does occur in the same phase of cess-pit digging on this site (eg Fig 82.60, COC F146, Period 3.1).

On stylistic grounds, early Colchester-type jugs with Rouen-style red and white slip decoration, as Figure 82.50, could date anywhere between c 1190 and c 1250 which is the date-range of this style of jugs in London-type ware (Alan Vince, pers comm). Thin-sectioning of Figure 82.50 proves its Colchester-type attribution beyond any reasonable doubt (see above p 108). The Rouen-style of decoration had a long currency on Colchester-type ware but late examples can be distinguished by their thin slip painting and highly debased designs. The earlier Rouen-style vessels (Figs 81 & 82.50-53, 55) are distinguished by their applied or high-relief slip decoration, their poorer fabric and glaze quality and by the fact that some vessels appear to be hand-made (Fig 82.50-51, 55). Figure 82.51 and 55, though not from phased sequences, have some useful dating associations. Figure 82.51 occurred in a pit context with greyware cooking pot rims of the necked type (c 1175-1250/75) and with one neckless type rim (c 1250/75-1375/1400), suggesting a deposition date of c 1250-75. Figure 82.55 also occurred in pit contexts associated with necked greyware cooking pot rims, a sherd of London-type ware, and a Hedingham ware early rounded jug with pellet decoration (Fig 49.5), all suggesting a deposition date of c 1200-1225/50.

The ceramic phasing, based largely on excavated sequences, provides a relative framework for the dating of Colchester-type and other local wares, but the dates assigned to these periods and phases are in several cases

rather too broad for close dating of specific forms and styles to be attempted. Historically-dated assemblages of Colchester-type ware are limited to Stratified Group 9 associated with the c 1382-1421 refurbishment of the town wall, and a single jug (Fig 79.41) found in the 19th century and said to have contained some coins and a deed of the reign of Henry V (1413-22).

For the most part, however, dating by association is the primary means of dating other than by reference to external parallels. There are numerous contexts in which Colchester-type ware is demonstrably earlier than Mill Green ware. The latter is reliably dated in London to c 1270-1350 (Pearce *et al* 1982), but later opinion (Meddens & Redknap 1992, 22) favours an earlier starting date of perhaps c 1250 from which date it may have circulated in Essex at least. Associations with either Mill Green ware or with coins or other datable artefacts are the main dating tools for 13th- to 14th-century Colchester-type ware. The earliest white-slipped jugs made in Colchester-type ware c 1200 may have taken white-slipped London-types jugs as their model (since these were never made in Hedingham ware, the only comparable local industry), but it is surely no coincidence that when Colchester-type jugs are associated with Mill Green ware they resemble the latter very closely.

A few other useful associations besides the illustrated stratified groups deserve to be mentioned:

CPS L48 (Period 3.2). Colchester-type ware associated in this context with a Henry III farthing, deposited c 1250-79 (CAR 4, 66), and with Mill Green ware. Colchester-type ware forms include the conical upper part of a baluster or pear-shaped jug (as Fig 71.4) with all over external white slip and clear green-flecked glaze. Also jug sherds with horizontal bands of slip (as Fig 82.55) with clear glaze, and jug sherds with horizontal and vertical strips (as Fig 73.11, 13) with clear glaze.

MID EL378 (Period 4.1). Associated with Alexander III of Scotland penny, deposited c 1280-1350 'with a date in the middle of that period most likely' (*ibid*, 67). Also occurs with Mill Green ware. Colchester-type sherds with all over white slip and either clear or green glaze.

LWC NL4 (Period 3.2). Layer in Lion Walk ditch sequence (Fig 208) producing Edward III farthing (minted 1335-43) with very tentative deposition date of c 1350-75 (*ibid*, 65). However, the presence of Siegburg and Langerwehe stoneware in upper layer interface suggests a date closer to c 1400. Colchester-type ware includes early and transitional-style sherds including a baluster jug with recessed conical base, a glazed jug handle with vertical slip stripe (as Fig 74.18), a cauldron (as Fig 89.108), a jar rim (as Fig 92.131), and a slip-painted bowl (Fig 94.156).

LWC BF46 (Period 4.1). Associated with Edward III half-penny deposited c 1400 (*ibid*, 65). Mixture of early and late style Colchester-type ware, plain and slipped. Includes thumbled base of baluster jug, slip-painted jug rim (as Fig 78.33), jar or bowl with bifid rim and slip decoration (as Fig 223.30, 37, Stratified Group 10), jar with bifid rim (as Fig 90.119), squat biconical bottles including waster Figure 103.218, possible costrel/cruet (as Fig 103.214), and a fragment of louver.

Colchester-type ware outlived Mill Green ware to associate freely in the late 14th and 15th centuries with Siegburg and Langerwehe stonewares. Towards the end of its currency, late Colchester-type ware is almost invariably found with

the classic type of small Raeren stoneware jug or mug which was imported into England in very large numbers from about 1475 until 1550 (Hurst *et al* 1986, 194; David Gaimster, pers comm). The decline of Raeren jugs around 1550 is paralleled by the decline of Colchester-type ware. Just as Raeren jugs were replaced by Frechen stoneware jugs, so Colchester-type ware was replaced by the finer post-medieval redware Fabric 40. Whereas the Colchester-type/Raeren association is as common as the Fabric 40/Frechen association in scores, if not hundreds, of contexts, a Colchester-type/Frechen association (devoid of Fabric 40 or later wares) is demonstrable in only around half-a-dozen instances.

Two dates for Colchester-type ware are provided by earlier excavations carried out elsewhere in Essex before the source of the fabric was understood. An almost complete louver was found during excavations at Great Easton, where a date of *c* 1300 or soon after was inferred on the basis of pottery dates (Dunning 1966a). This louver has subsequently been recognised as Colchester-type ware (*CAR* 3, 211). The other excavation, at King John's Hunting Lodge in Writtle, produced several vessels, apparently Colchester-type ware, from deposits dated to Writtle periods I and II (1211-*c* 1306 and *c* 1306-1425 respectively; Rahtz 1969, 94, fabric B, figs 53.31 & 54.37 & 49). Although it cannot be certain that these are all Colchester-type ware, a sherd of this fabric from the Writtle type series, which was examined by the writer, gives every outward appearance of being so.

## Vessel typology

[Figs 70 & 120]

As one might expect from such a long-lived ware, the variety of forms represented among the excavated material is very considerable. The great majority (87%), however, are broadly divisible into various types of jars, jugs and bowls with the remainder comprised of a diverse range of relatively minor forms. At different times, the vessel composition of Colchester-type ware would have changed. The earliest assemblages are dominated by jugs with perhaps a few jars/cooking pots and bowls also in production. In the 14th century, bowls became slightly more common and an increasing variety of minor forms came into production. The 15th and 16th centuries saw a significant increase in the numbers of storage jars and bowls in production and the relative decline of jugs.

### Jugs

**Manufacture.** The earliest stratified Colchester-type sherds all appear to come from jugs. Several of these, including some with Rouen-style decoration (Fig 82.50, 51, 55 & Pl 3), were definitely hand-made, as is shown by their internal irregularity, although the rims may have been wheel-finished. These early jugs have a patchy, pitted glaze probably dusted on as a raw lead compound. On an early (Period 2.2-4) jug body sherd from Lion Walk, covered with orange-pink slip, the coincidence between the lower slip and the green-flecked glaze limit is so close that the slip and glazing agents might have been applied as a suspension or mixture in a single operation (Hilary Healey, pers comm). All other, presumably later, jugs appear to be

wheel-thrown. Glaze runs on several of the most complete baluster jugs show that jugs were fired both upright and upside-down. Other manufacture details are discussed with the specific jug forms below.

### Baluster jugs

(Fig 71.1-10, 73.11-15, 74.16-23, Fig 72 & Pl 2)

The baluster analogy is here rather loosely used to denote jugs with an ovoid body, a cylindrical or slightly flared neck and a splayed or pedestal base which is normally thumbled. As a general observation, on earlier balusters the ovoid body merges gently into a simple splayed thumbled base with a sagging floor (eg Fig 71.1, 8-9 & Fig 73.11, 13-14). On later balusters, the distinction between body and base is more marked; the bases are more flared and pedestal-like, often with a flatter or even concave floor (Fig 73.15, Fig 74.19-23), though there are always exceptions to the rule.

Baluster jugs can be divided into a number of 'types' based on form and/or decoration. However, as the number of complete or nearly-complete baluster jugs available is not much more than those illustrated here, there is a degree of arbitrariness and overlap in the 'types' defined below.

#### a. White-slipped ('early style') baluster jugs

(Fig 71.1-4, 6-7, 9-10 & Pl 2)

These are covered all over, or more precisely the upper two-thirds of the jug is covered, with a white slip under a copper-flecked green glaze. The slip usually covers the rim and extends some distance inside the neck. It also covers the handle. Slip was probably applied as a fairly thick liquid wiped on by hand. Figure 71.10 is unusual in having an orange-pink slip. At the lower limit, above the base, the slip on some examples has clearly been shaved during knife-trimming of the lower part of the vessel. On Figure 71.1, and possibly 9, the knife-trimming has produced a series of vertical facets. The glaze covers most of the slipped area externally, but on Figure 71.1 and 4, which appear to have been fired upright, it avoids the rim and most of the handle area (Pl 2). The largest blotches of copper-green are also concentrated in a bib on the front of the vessel suggesting the potter held the jug handle-down and dusted the glazing agents (lead and copper) over the front. Most of the glazed area, however, is copper-flecked to some degree.

This type includes balusters with cylindrical necks (Fig 71.1-2), sometimes with a shoulder cordon (Fig 71.2), flaring necks (Fig 71.3, 4, 6, 10), and upwardly-tapering necks giving a more pear-shaped profile (Fig 71.9). A variety of simple and thickened rims are present. Thickened, flat-topped rims are commonest (Fig 71.9), followed by varieties of simple inturned or carinated rims, as on Mill Green jugs (Fig 71.2-4, 6). Others are plainer, sometimes internally bevelled (Fig 71.7, 10), and some have a hint of a collar (Fig 71.1). Handles are of oval or elliptical section, usually plain but in some cases furrowed (Fig 71.9-10). Stabbing on handles is rare, and the pulled 'ears' on the top of Figure 71.9 are so far unique. In most cases, where it can be inferred, the method of handle attachment was to push out the neck and body wall from within, so as to join it to the thickened ends of the handle. The depression thus caused was then normally plugged with a piece of clay and smoothed over. This was the usual method of handle attachment for most types of Colchester-type jugs. Sometimes where the handle has become detached, the clay plug or 'rivet'

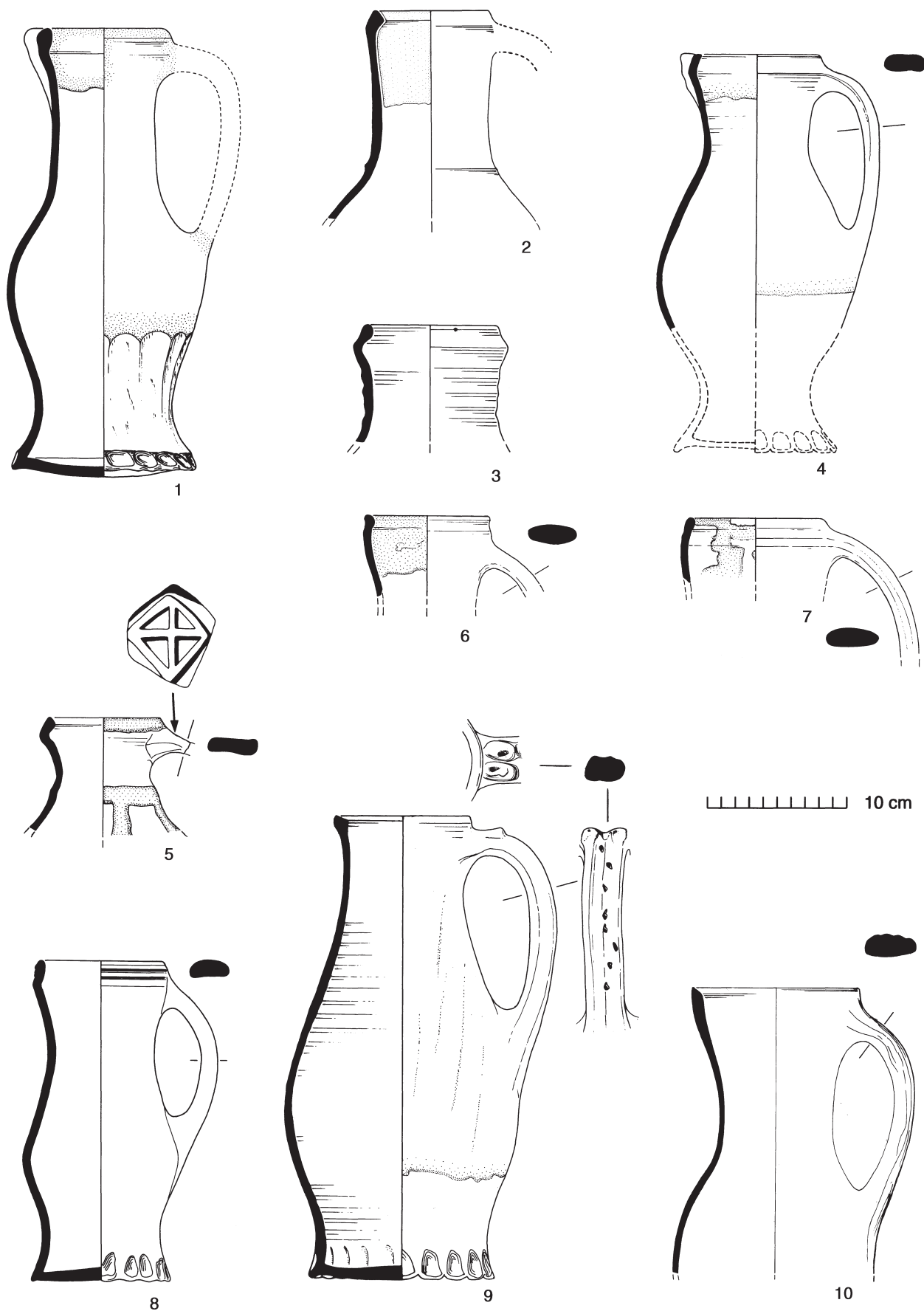

Fig 71 Colchester-type ware: baluster jugs with early style white slip and green glaze (nos 1-4, 6-7, 9-10); (nos 5 (with early style thick slip decoration) & 8 (plain)). 1:4; stamp detail 1:1.





Fig 72 Colchester-type ware: two baluster jugs with early style thick slip decoration c 1300 (height of left jug 294 mm).

remains attached to the handle stub (eg Fig 76). In some cases, the upper end of the handle may have been plugged through a hole in the neck wall and then smoothed over. Spouts, where surviving, are of the simple, pulled, pouring-lip type (Fig 71.1, 4).

b. Baluster jugs with ('early style') applied strips or thick slip painting (Fig 71.5, Fig 73.11-14, Fig 72):

Forms are not very different from the white-slipped balusters and show at least as much variety. Strips of white clay are applied to the body of the vessel and flattened-out, or alternatively the strips are smeared on as a thick slip paint. An arrangement of vertical strips attached to a horizontal strip on the neck/shoulder is common (Fig 71.5 & Fig 73.11,13). Figure 73.11 is one of three near-identical strip jugs from a single pit on the Middleborough site. It is unusual in having a band of fine grooving or combing on the neck, while Figure 71.5 (from the same site) is unique in having a stamped device on top of the handle. Variations of the vertical strip scheme are not uncommon. On Figure 73.13, the strips are forked lower down to form a frieze of inverted 'Y's, while on Figure 73.14 the verticals are crossed by crescent-shaped strokes perhaps to simulate vegetation. Figure 73.12 is remarkable both for its form and decoration which are clearly in imitation of Mill Green ware polychrome baluster jugs (Alan Vince, pers comm; Pearce *et al* 1982, fig 7). Broad lentoid 'gadroons' of white slip are painted on the body, and dots of white slip have been dabbed on to the ribbed and unglazed neck. Clear glaze covers the body. The slightly faceted rod-section handle is also unusual. To this category also a few sherds with true polychrome decoration in the Mill Green-style could be added (Fig 82.56-58; Pl 4), as these almost certainly come from baluster jugs as Figure 73.12 and some even occurred in the same context as the latter on Long Wyre Street (Stratified Group 8, Fig 219.2-3). Sherds from a minimum of three polychrome jugs were found in closely associated

contexts on this site and nowhere else. Curiously no true Mill Green ware was found there. Colchester-type polychrome sherds are a hybrid class between the all over slipped balusters and those with thick slip painting. The exterior of these sherds is covered with white slip over which decoration in dark red-brown and green has been painted. Figure 82.56 (oxidised fabric) is decorated with alternating vertical strokes of red-brown and green paint, whereas Figure 82.57-58, probably from the same reduced jug, have a more typical Mill Green polychrome design of chevrons formed of a central broad red-brown band with dabbed white dots or pellets, flanked by parallel strokes of green. A sherd from a third polychrome jug (?or part of Fig 82.57-58 and from the same context) has the same basic design as the latter, except that the bands are arranged as two adjacent curves which are possibly ovals or arcs (not illustrated; cf Pearce *et al* 1982, pl 1). All the polychrome sherds are covered with a clear glaze. A very similar polychrome sherd of Fabric 21 (?perhaps Colchester-type) is known from Chignall St James near Chelmsford (Walker 1992b, fig 5.15).

It is also worth noting here the existence of a remarkable and virtually complete polychrome jug from a medieval well at Bramford, Suffolk (see also p 101). This is of baluster form and similar in style and decoration to Figure 73.12 except that the body of the Bramford jug has, uniquely, been fluted with eight 'gadroons' (Erith 1972, fig 4.7). Alternating gadroons have been painted all over with white slip under a copper-flecked green glaze, while the intervening gadroons are plain but covered with white-slip dots in debased Rouen/Mill Green style. A single sinuous slip stripe runs the length of the elliptical handle. This vessel was examined by the writer shortly before auction in London in 1996 (see colour photograph in auction catalogue: Horne 1996, no 446). It is not, as was previously thought, an example of Mill Green ware, but most probably a Colchester-type product or, at the very least, an East Anglian redware.

Smaller jug fragments, some possibly from baluster jugs, have also been found with a simple arrangement of horizontal strips (as Fig 82.55).

Other fragments with Rouen-style decoration might also come from baluster jugs (eg Fig 82.52-53; see below). One other probable baluster jug with thick slip painting is unusual in having an applied bridge spout (Fig 74.17), one of only two such vessels in Colchester-type ware.

All baluster jugs with applied or thick slip decoration are glazed on the upper two-thirds, either with a clear glaze or a sparsely copper-flecked glaze. Figure 73.14 is covered with a reduced, copper-flecked glaze which even covers the base. It was clearly fired upside-down.

c. Baluster jugs with ('middle style') thin slip painting (Fig 73.15, Fig 74.18-19, & Pl 5):

Too few profiles have been found to generalise about forms, although it is notable that Figure 74.18 and 19 are particularly tall and slender. These have typical 'middle style' decoration (see pp 172-3) which includes slip bands on the rim, strokes down the back of the handle, and scrolling decoration on the body (Fig 74.18). Figure 74.19 has a late medieval merchant's mark on the front. Although merchants' marks could be very long-lived (Girling 1964), an identical mason's mark occurs in Canterbury Cathedral in three late 14th- to 15th-century contexts, ie the nave (1377-1405), Bell Harry staircase (1433), and the Lady Chapel (1440) (C Elam,

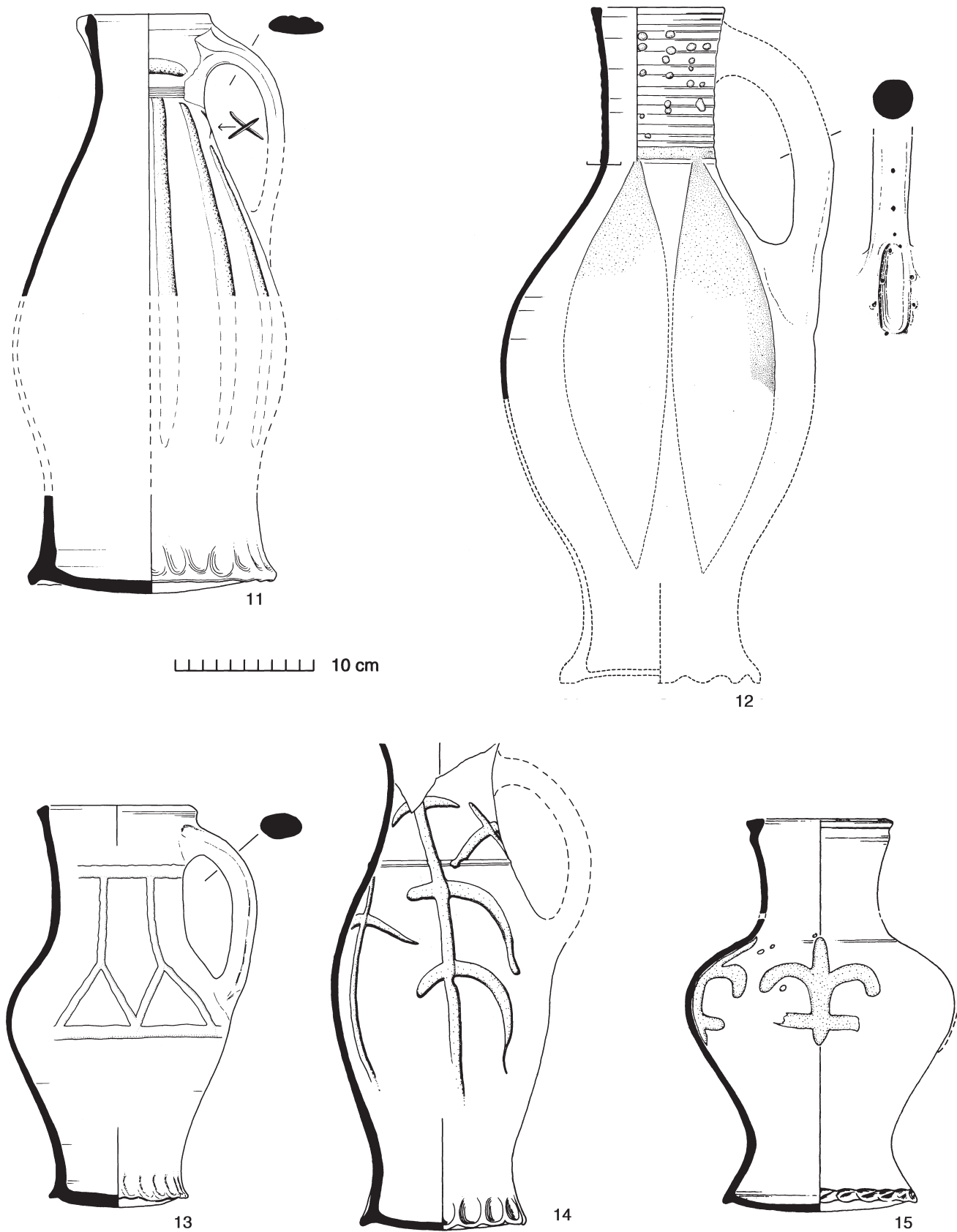

Fig 73 Colchester-type ware: baluster jugs with early style thick slip decoration (nos 11-14); baluster jug with middle style slip decoration (no 15). 1:4.

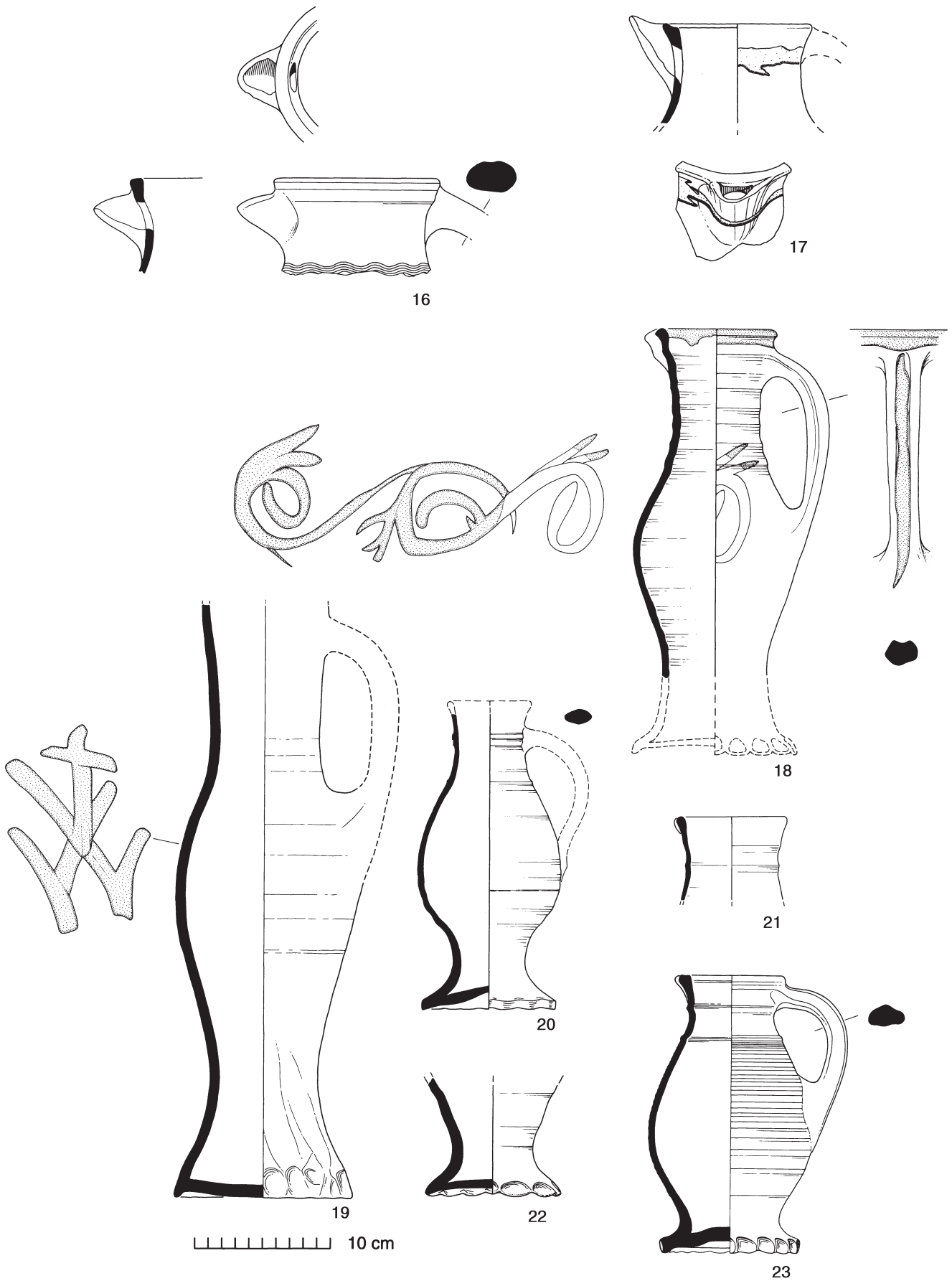

Fig 74 Colchester-type ware: ?baluster jugs with applied bridge spouts (nos 16-17); baluster jugs with middle style slip decoration (nos 18-19); 'metal copy' baluster jugs (nos 20-23). 1:4.

unpublished study). This is obviously a coincidence, but it probably dates the popularity of this particular mark or symbol. This jug is also notable for the vertical-oblique knife-trimming of the base. Figure 73.15 combines 'middle style' fleur-de-lis painting on the body with 'late style' slip dashes on the rim. All three illustrated jugs are unglazed except for a bib of clear glaze on the front of Figure 74.18-19 and a bib of green glaze on the front of Figure 73.15.

d. Late medieval 'metal copy' baluster jugs (Fig 74.20-23): The characteristics of this type are an exaggerated baluster form with a broadly splayed and, at times, almost discoid pedestal base. The latter is usually thumbed, the thumbing often superficial with a slightly frilled or faceted look (see also Stratified Group 10, Fig 222.19). The floor of the base is either flat or more often concave, sometimes with a 'kicked-up' dimple in the centre (Fig 74.20, 23). The body is ovoid and often finely rilled with cordons or ribs on the shoulder and neck. Rims are either plain and slightly thickened (Fig 74.21) or thickened, flat-topped and slightly concave on the upper surface (Fig 74.23). Handles are of oval or characteristic sub-lozenge section. The overall impression, suggested particularly by the exaggerated pedestal base and the neck cordons, is of a copy of either metal or imported stoneware jug forms. Most examples are fairly small and occur in the late Colchester-type fabric or in a lighter more micaceous transitional fabric (Fabric 21/40), usually under a clear glaze, except for the pedestal area. The same fabric, glaze character and sub-lozenge handle sections are shared by late medieval cups and drinking vessels in Colchester-type ware (see below). Although most jugs of this type are plain, a few (perhaps slightly earlier) examples with exaggerated pedestals occur with an all over external white slip and a copper-flecked green glaze (Hurst 1961a, fig 1.2).

e. Miscellaneous unslipped baluster jugs (Fig 71.8 & Fig 74.16):

This is a catch-all category for baluster jugs that do not fit comfortably into any of the above categories. Besides the majority of 'metal copy' balusters, some other types of baluster jug were definitely unslipped in any way, but only complete or near-complete examples prove this as the area occupied by slip painting on some jugs (eg Fig 74.19) was often quite small and could be missing from more broken examples. There is no noticeable typological trend in this category, particularly as so few definite examples have been excavated. Figure 71.8 is complete and unslipped but with a clear greenish glaze covering the upper half, especially the front. It has a typical inturned rim similar to all over slipped baluster jugs, with which it is probably contemporary, but with the addition of deep horizontal grooves on the outside, a feature noted on other Colchester-type jugs of suspected 14th-century date (Fig 75.26). Another plain baluster jug in the Colchester Museum is complete but for the rim, and has a similar form to Figure 74.19 but smaller. A bridge-spouted jug, Figure 74.16, may also belong to this category or could just possibly be of 'early rounded' form. The fabric is of early character, probably 13th century, with a dark green copper-flecked 'splash glaze' covering the exterior. There are pellets of raw lead embedded in the surface, and glaze dribbles suggest an upright firing position. Other unusual features of this jug besides the applied bridge spout are the simple collared rim, the thick oval-section handle (possibly plugged through the wall), and in particular the combed horizontal wavy band on the neck (see other decorated sherds below). The manner in which the whole top of the jug has detached

from the rest of the body, in a roughly straight line, suggests the jug may have been of composite manufacture with a wheel-finished top luted on to a hand-made body.

### Squat jugs

These are slightly taller than they are wide. Bases are sagging unless flattened accidentally during firing (Fig 75.29). Generalisations about other more specific features of this jug form are restricted to the latest two types (c and d below) which are plentiful, whereas the earlier types (a and b) are too scarce and fragmentary to gauge the frequency of specific traits. All squat jugs appear to be wheel-turned, but some of the largest jugs could have been made in sections and then wheel-finished, although there is no definite evidence for this except in the case of a unique 13th-century 'jug/cistern' (Fig 84.73) which was definitely hand-made. As with most baluster jugs, the upper end of the handle seems to have been attached by pushing out the vessel wall from inside and keying this deeply into the handle, then plugging the cavity thus created with a piece of clay and smoothing this over (Fig 76). The lower end of the handle was not so deeply keyed to the body wall, but there is often a 'rosette' of finger impressions on the inside of the vessel where the wall was pushed out to meet the handle (Fig 77). A thumbed pit or groove at the base of the handle was sometimes made to secure it more firmly (Fig 75.30). A pulled pouring-lip is normal.

The types of squat jug defined below are subject to some degree of overlap.

a. White-slipped ('early style') squat jugs (Fig 75.24):

The illustrated example is the only definite example of this type identified, although more fragmentary examples may have gone unrecognised. The fabric is duller and siltier than normal, but could still be Colchester-type. White slip covers the upper two-thirds of the vessel and this is covered, mostly over the front, by a decayed copper-flecked green glaze.

b. Squat jugs with ('early style') thick slip painting (Fig 82.60):

These are rare and the complete form is unknown. Figure 82.60, however, appears to represent an unusually squat form of jug. The body is decorated with thickly painted or smeared lines of white slip forming a pattern of concentric or recessed chevrons linked at points by ladder-like horizontal 'rungs' or lines. In plan, this scheme would form a five-pointed star with chevron fillers between the points. Clear glaze covers the surface but dies out at the maximum girth, where there is evidence of knife-trimming.

c. Squat jugs with ('middle style') thin slip painting (Fig 75.25-28, Fig 78.31-33 & Fig 83.61, 64):

These have a markedly globular body, which is almost spheroid on the largest examples (Fig 78.31-32). The smaller squatter jugs (Fig 75.25-28) may be a sub-type, perhaps with a different function to the larger spheroid jugs which may have been for storage. In general, when compared to later squat jugs (type d, below), middle style squat jugs have more cylindrical or slightly flared necks. The rims are mostly variations of the ubiquitous external triangular bead, sometimes sharply bevelled externally (Fig 78.31), or more developed and overhanging with a bulge or carination below giving a collared effect usually in association with a flaring neck (Fig 78.33). Other equally simple types of thickened, thickened flat-topped, and beaded rims occur either with or without a bulge below (Fig 75.25-28 & Fig 78.32).

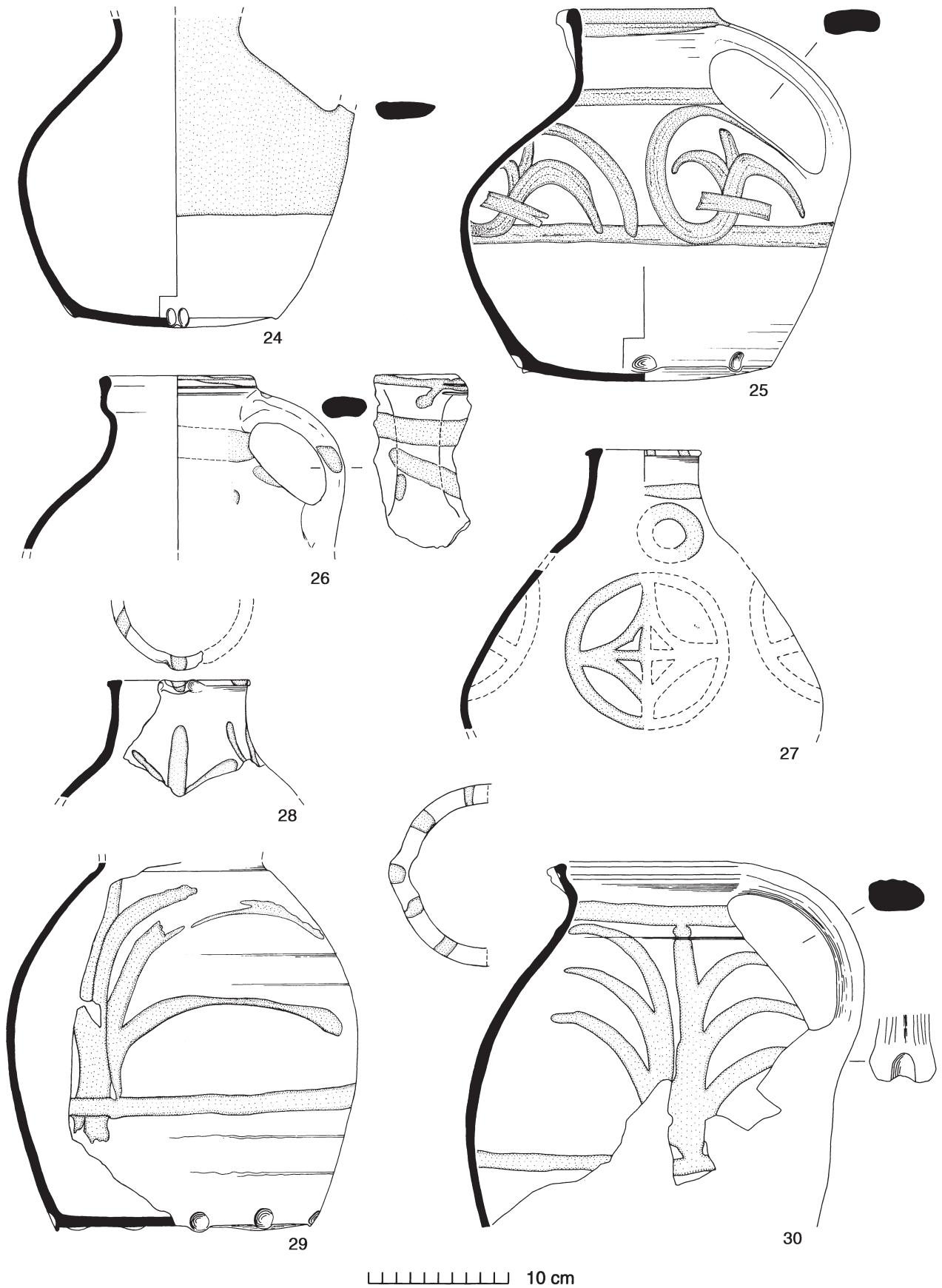

Fig 75 Colchester-type ware: squat jug with early style white slip and green glaze (no 24); squat jugs with middle style slip decoration (nos 25-28); squat jugs with late style slip decoration (nos 29-30). 1:4.



Fig 76 Colchester-type ware: jug handles (upper internal view) probably from squat jugs showing clay plugs used to fill cavities pushed into handle terminals during attachment to rim (NB thumb-nail 'keying' on left example, possibly a cistern handle); centre example upside-down.

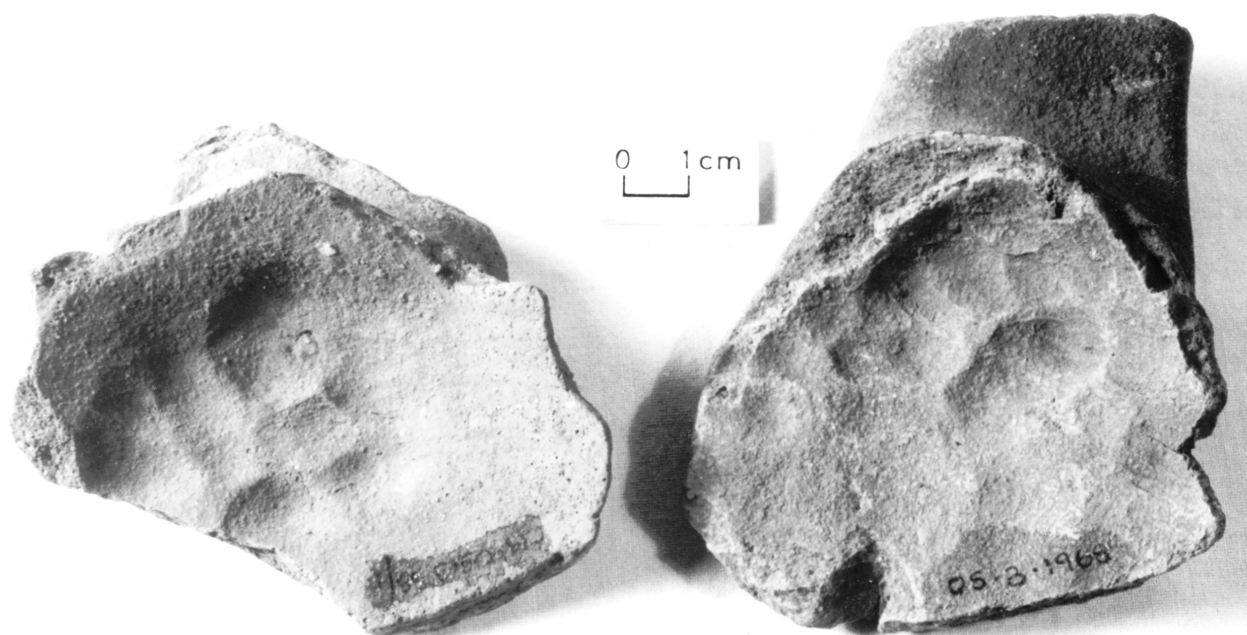

Fig 77 Colchester-type ware: detail of lower internal handles from squat jugs showing keyed 'rosette' of finger impressions made during attachment to body (both from Great Horkesley kiln-site).

The smaller jugs have simpler, narrow strap handles of rounded, crescent-like section (Fig 75.25-26), while the larger jugs have relatively broad strap handles with a central furrow and two or more ridges. Glaze is sparse on jugs of this type particularly on the largest. On Figure 75.25, the slip-painted zone is covered with a clear glaze that avoids the rim and the handle area. Figure 75.27 has a sparse bib of pale greenish glaze. Figure 78.31-32 have only traces of clear glaze, although the fronts of both jugs (both missing) probably had small bibs of clear glaze. Other decorative features include incised horizontal grooves below the rim on one example (Fig 75.26) and impressed 'ears' on the neck/handle junction of a few others (Fig 78.32).

Painted slip decoration on jugs of this type is in the more individualistic 'middle style' (see pp 172-3) which includes a variety of motifs, eg stylised vegetation (Fig 75.25-28), and geometric and/or abstract designs (Fig 75.27 & Fig 78.31-32). Figure 75.27 is probably the most unusual

jug of this type as much for its almost conical, flask-like form as for its unusual wheel-like decoration. The possibility that it is some other specialised form, such as an industrial vessel, cannot be ruled out.

d. Squat jugs with ('late style') thin slip painting (Fig 75.29-30 & Fig 78.34-36):

The body is more robust/thicker-walled and more ovoid or pear-shaped than the other types. The neck is usually shorter and flaring, with an externally thickened sub-triangular or simple beaded or thickened rim nearly always above a bulge giving a slackened collar-like effect. A lower bulge or cordon at the neck/shoulder junction is also common. Handles are of characteristic narrow strap section with a deep central furrow between two prominent ridges (Fig 78.34, 36; see also Cunningham 1982a, fig 30.56), or else of simpler oval section grooved down the back (Fig 75.30). Glazing is either completely absent or there is just a bib of clear glaze on the front below the pouring-lip.

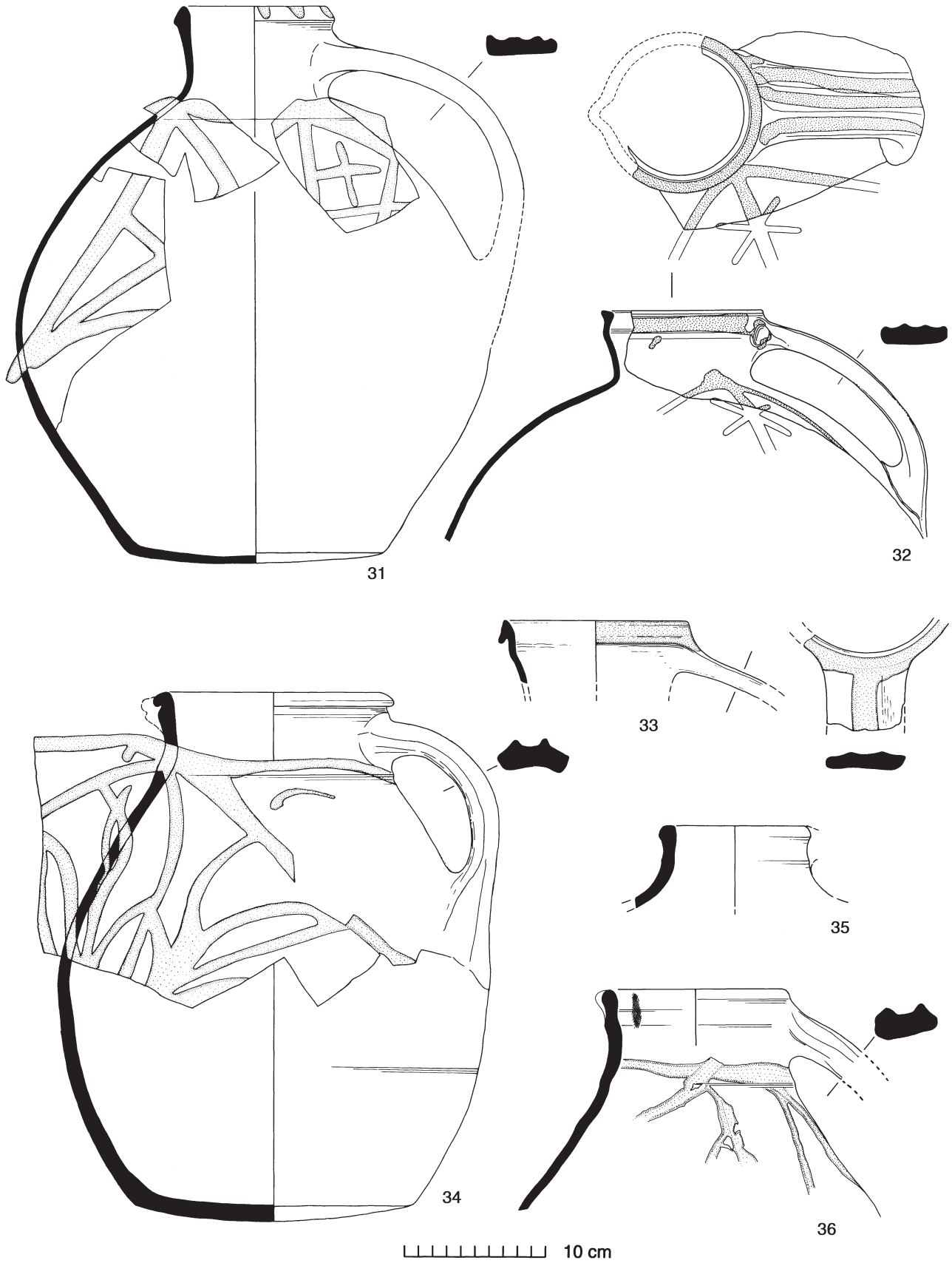

Fig 78 Colchester-type ware: squat jugs with middle style slip decoration (nos 31-33); squat jugs with late style slip decoration (nos 34-36). 1:4.

Slip decoration is in the ‘late style’ (see p 173), consisting for the most part of stylised vegetation (spiky foliage) or more abstract designs on the body and slip dashes on the rim (Fig 75.30).

Jugs of this type are very common and share several features with ‘late style’ cisterns (see below), some of which are very jug-like.

#### Small rounded jugs (Fig 79.37-39)

This is a minor category represented by a few complete examples in the Colchester Museum and more fragmentary examples from the excavations, all apparently late medieval. Figure 79.37 and 38 are more similar in fabric and form, with a squat/rounded body, sagging base and a tall gently flared neck. All examples have a bib of clear glaze on the front except no 39 which has only a few specks of glaze. Pouring-lips occur on nos 38 and 39 but not on no 37. The smaller looped handle of the latter, attached to the neck rather than the rim, is reminiscent both of Colchester-type ‘Cheam copy’ jugs (see below) and German stoneware drinking jugs, suggesting that this jug might also have been used for drinking. The ‘middle’ or ‘late style’ painted slip hoops on the latter are also unusual. Figure 79.39 (Stratified Group 16) is in a finer transitional fabric, has a more ovoid body, and might have had a thumbed pedestal base similar to the ‘metal copy’ baluster jugs (see above). Handles of sub-lozenge section on nos 37 and 39 (the latter thumbed at the bottom) reinforce the impression of their late dating.

#### ‘Cheam copy’ jugs (Fig 79.40-45; Fig 80)

A small but significant category is represented by about fifteen to twenty examples in museum collections and excavated material. Some of these are undoubtedly close copies of Cheam white-ware drinking jugs, both the barrel-shaped and the biconical forms (Pearce & Vince 1988, figs 120-22), whereas others seem to be somewhat looser interpretations of these or are perhaps only coincidentally similar. All examples are fairly small. Besides this, the main shared characteristics are a flat base, a barrel-shaped or biconical body (or approximations of these), a narrow cylindrical or gently flaring neck, and a handle attached below the rim or lower down on the neck and to the maximum body girth or just above. Other characteristics include the absence of a pouring-lip (except on no 40) and generally the presence of a thickened flat-topped rim and a narrow oval or rod-section handle. Barrel-shaped and biconical forms occur in about equal numbers.

Around two-thirds of all examples are covered to some degree with white slip under a clear glaze flecked at the front with copper-green (nos 42-43, 45 and Fig 80) or with just a bib of clear glaze on the front below the rim (no 44). Unslipped jugs have just a bib of clear or brownish glaze (nos 40-41). On most slipped jugs the slip and glaze cover the upper half of the vessel including the handle and rim, and the slip also extends up to 2 cm inside the neck ending in a straight line. This fact, the uniform application of the slip, and the presence of occasional dribbles suggest that some of the jugs were held by the base and dipped into a bath of liquid slip (eg nos 43, 45). Some jugs also were clearly fired upside-down. Figure 79.42 has just a bib of liquid slip under a greenish glaze, while no 44 has a painted rectangular bib of slip under a clear glaze which has etched into the slip in places.

Even the most faithful copies of Cheam white ware (including nos 41 and 45) lack the internal stabbing of the handle junction so typical of Cheam jugs (*ibid*, 73). Handles appear to have been luted on, though on one or two examples, the handle may have been pushed through the body wall (eg nos 41, 44). The shallow stabbed pits on the handle of no 40 are an unusual feature for Colchester-type ware and may be an attempt to copy the stabbing on Cheam or other Surrey white-ware jugs, but the presence of a pouring-lip, the unusual ‘ledged’ rim, and typical Colchester-type ware furrowed handle are otherwise out of character with other ‘Cheam copy’ jugs. Another ‘Cheam copy’ jug from Colchester Castle has a Colchester-type external triangular bead rim which is sharply bevelled (Cunningham 1982a, fig 31.71).

#### Late medieval conical or cylindrical jugs (Fig 79.46)

This is a minor category represented by only two definite examples from the excavations, but also known from excavations at Braintree (Huggins 1986, fig 6.12-13). The form is fairly tall with a slightly conical or upwardly tapering body and a flat base heavily knife-faceted on the exterior. The handle is of typical late medieval/post-medieval sub-lozenge section and is attached to a shoulder bulge and a lower body bulge where it is secured by a deep thumb impression. One of the Braintree jugs has a deep funnel-like carinated rim. The rather metallic-looking profile of these jugs may have been inspired by Cistercian ware forms. Both excavated examples are in the late micaceous transitional fabric and are covered externally with clear glaze as far as the faceted base. The second example (1.81 EF106, not illustrated) also has broad faceting around the base, but in this case the facets were made with the side of the thumb rather than by knife-trimming. The fabric of the latter is unusually fine and micaceous (except for rare very coarse inclusions of flint and red clay pellets) and very similar to medieval Hedingham ware (Fabric 22), but the form is otherwise unparalleled in that fabric. However, this second example, at least, might have been produced somewhere in the Hedingham-Braintree area fifteen miles or so west of Colchester.

#### Miscellaneous jugs (Fig 79.47; Fig 82.48-49)

A small and unusual jug (Fig 79.47) is represented by a sole example in Colchester Museum. In form it represents something of a hybrid between a jug and a mug or tankard with a gently concave cylindrical body, a rounded base and a small pouring-lip. It was clearly used for heating liquids as the base is heavily sooted/scorched. Possibly it was a measure for dispensing hot drinks such as toddy. The fabric is late but coarse, and covered both inside and outside with a clear glaze except the underside which is only patchily glazed. A 15th- to 16th-century date is suggested.

Figure 82.48 may be related to the conical or cylindrical jugs discussed above, but exhibits a number of unusual features that set it apart even from that unusual category. The vessel has steep, gently flaring walls and a flat base. The fabric is rather dull and more silty than usual, something akin to Guy’s ware (Fabric 55, see p 187) but probably of local manufacture. It is completely unglazed, but on the outside there are irregular smears of thick white slip bearing finger impressions. The bold grooves on the body and prominent internal throwing lines are also unusual. Possibly this is not a jug but something more unusual such



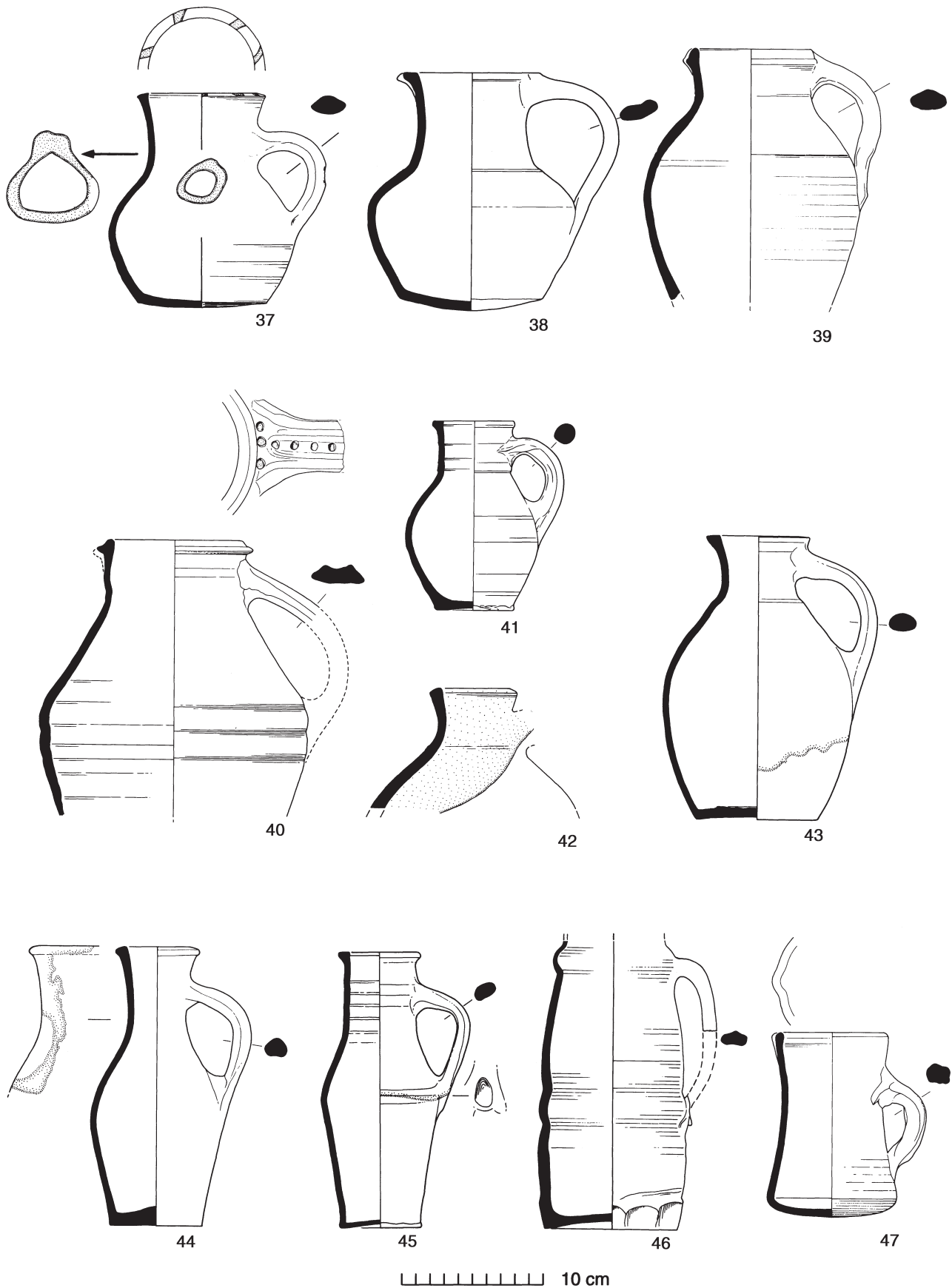

Fig 79 Colchester-type ware: small rounded jugs (nos 37-39); barrel-shaped and biconical 'Cheam copy' jugs (nos 40-45; no 41 Ardleigh 'hoard' jug c 1413-22); conical or cylindrical jug (no 46); miscellaneous jug or measure (no 47). 1:4.



Fig 80 Colchester-type ware: 'Cheam copy' jugs with white slip and 'bibs' of green glaze, c 1375-1450+ (height of far left jug 210 mm).

as an industrial vessel. A late medieval date seems likely, but there is no associated dating evidence.

Figure 82.49 is an example of a recessed jug base, possibly from a baluster jug. Colchester-type baluster jugs very occasionally have this base form. The unusual thing about this jug, however, is the lattice decoration incised while the jug was still leather hard. There is no slip but the exterior is covered with a patchy greenish glaze. The fabric is of early type, and other recessed bases from the town have 14th-century associations.

Miscellaneous decorated jug sherds (Fig 82.50-60, Fig 83.61-72, & Pls 3-4)

Some of these have been discussed above or mentioned in connection with the jug forms to which some can probably be assigned. Other jug sherds, however, cannot be assigned to specific forms but are notable in some cases for their decoration. These are treated in catalogue form below.

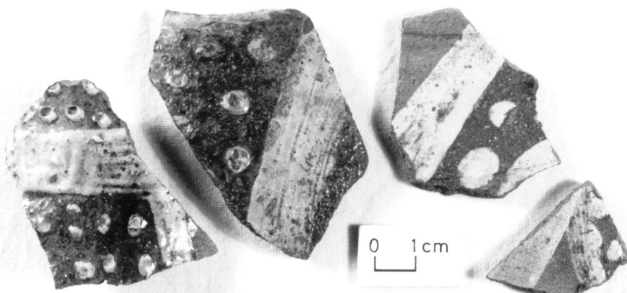

Fig 81 Colchester-type ware: jug sherds with Rouen-style decoration, 13th-14th century.

Fig 82.50. Shoulder sherd from a jug possibly of baluster or rounded form. Possibly hand-made. Early fabric (see above, p 108 for thin-section description). The body is decorated in the Rouen style with a broad vertical stripe of red paint flanked by two white stripes, all thickly painted. A clear pitted glaze covers the exterior. Apart from the Mill Green-style polychrome sherds illustrated in Figure 82.56-58, this is the only other Colchester-type jug with red as well as white paint. Probably early to mid 13th century. Associated with Fabric 13, Fabric 22 and a brown glazed floor tile.

Fig 82.51 & Pl 3. Body sherd with separate handle sherd. Both apparently from the same wide-bodied hand-made jug, possibly an early rounded jug or an unusually large baluster jug. Early fabric. Rouen-style decoration of applied white stripes and pellets. The pellets possibly occur on a painted red background but this is uncertain. The exterior is covered with a pitted clear glaze. Probably early to mid 13th century (see above, p 112 for dating evidence).

Fig 82.52-53 & Fig 81. Body sherds from two probable baluster jugs decorated in the Rouen style. The design on no 52 is probably chevrons suspended from a band at the neck/shoulder junction. The slip bands on both are heavily painted and the pellets have been dabbed on, perhaps with the end of a stick or quill, and then pitted in the centre. Early fabric. 13th or early 14th century.

Fig 82.54. Body sherd in late unglazed fabric with debased Rouen-style decoration. Probably 15th century.

Fig 82.55 & Pl 3. Body sherds from a hand-made jug possibly of rounded or baluster form. Early fabric. Decorated in a Rouen-related style with thick horizontal white stripes. Exterior covered in a pitted clear glaze. Probably early to mid 13th century (see above, p 112 for dating evidence). A jug rim from the same context, but not apparently from the same jug, is of externally thickened flat-topped form above a gently flared or cupped neck. It also has a pouring-lip (not illustrated; similar to Hedingham rim Fig 49.5).

Fig 82.56-58 (Pl 4). Jug sherds with Mill Green-style polychrome

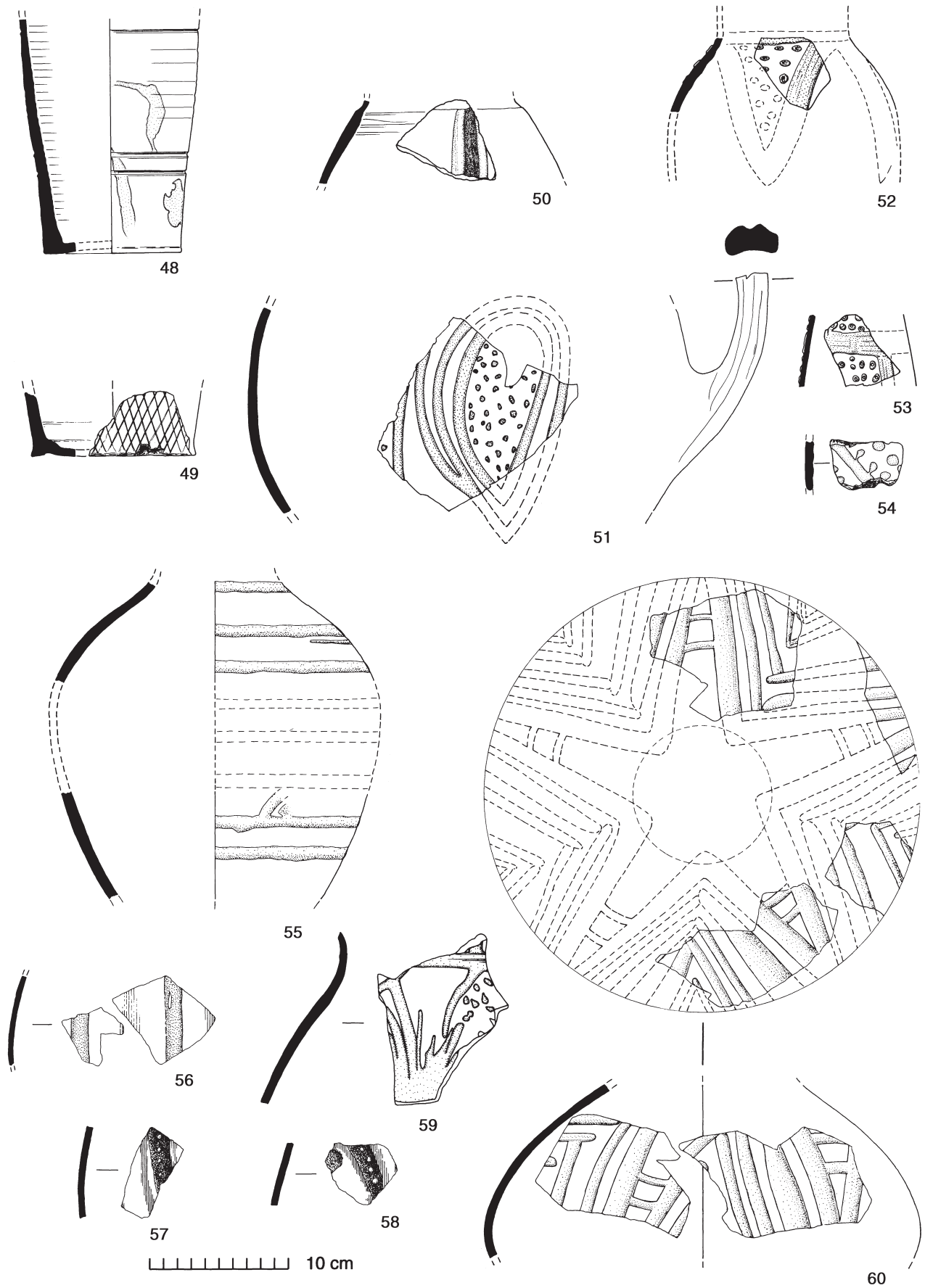

Fig 82 Colchester-type ware: miscellaneous decorated jug sherds (nos 48-60). 1:4.

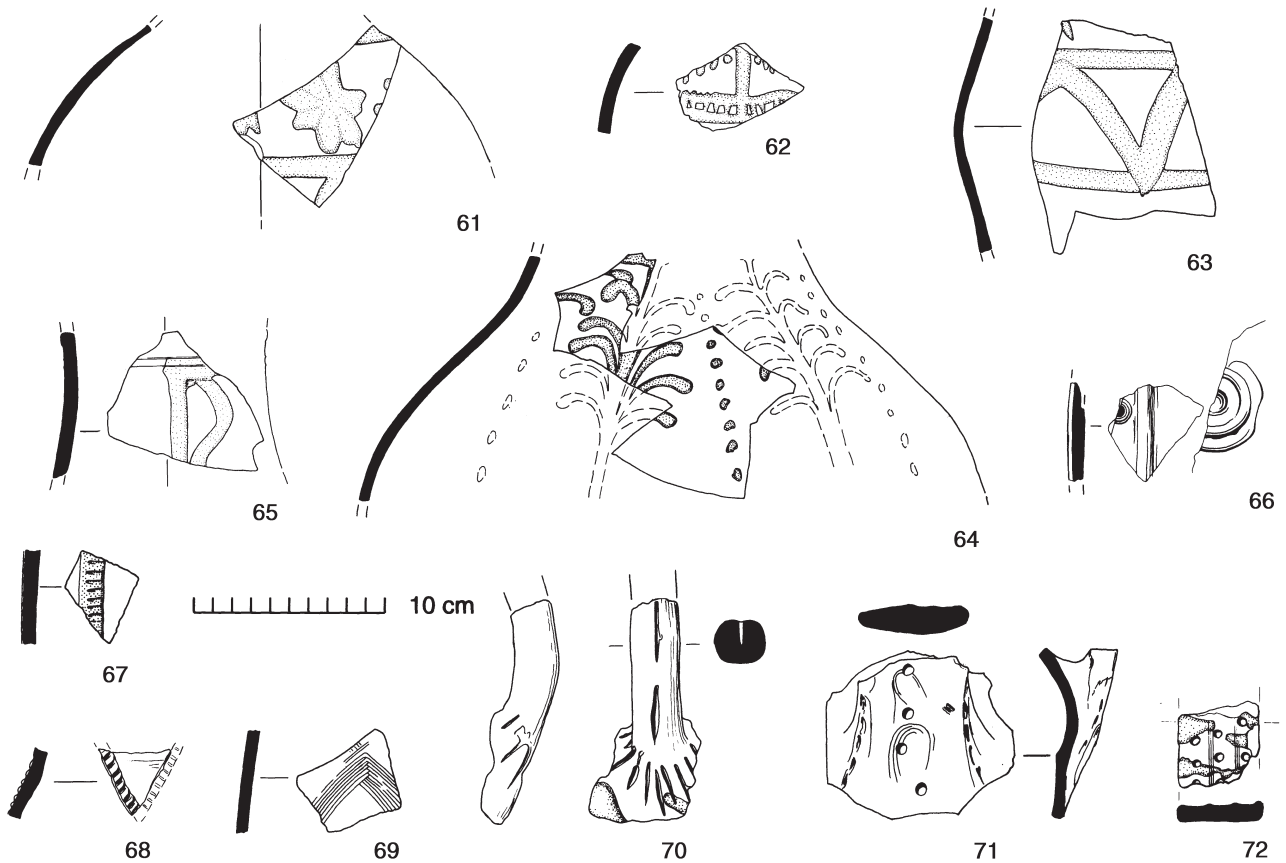

Fig 83 Colchester-type ware: miscellaneous decorated jug sherds (nos 61-72). 1:4, stamp detail 1:1.

decoration. These have been considered above with baluster jugs with thick slip painting (p 115). Date c 1290-1325 (see below, p 127).

Fig 82.59. Unglazed body sherd in late fabric from a jug (or jar) possibly of squat or rounded form. Decorated in debased Rouen style with stylised foliage and dots. Probably 15th to 16th century.

Fig 82.60. Body sherds in early fabric from a squat jug. Discussed with squat jugs with thick slip painting (see above, p 118). Date c 1250-1325 (see below, p 128).

Fig 83.61. Unglazed body sherd from ?squat jug in late fabric. 'Middle' or atypical 'late style' slip decoration of painted rosettes. Probably 15th to 16th century.

Fig 83.62. Unglazed body sherd in late fabric. Unique slip-painted decoration or motif, possibly debased Rouen style with ladder-like element and dots. Stratified Group 12, c 1475-1525.

Fig 83.63. Unglazed jug/jar body sherd in late fabric. Unusual 'middle' or 'late style' arcaded or chevron frieze (see louvers Figs 106 & 107.244-245 for similar decoration). Date probably c 1375/1400-1525.

Fig 83.64. Unglazed body sherds from squat jug in late fabric. 'Middle' or 'late style' slip decoration of painted upright fronds flanked by vertical rows of dots. Probably 15th century.

Fig 83.65. Neck sherd probably from a baluster jug with 'early style' thick slip painting, possibly a vertical wavy line flanked by vertical straight lines. Early fabric but unusually coarse. Dark green-flecked glaze exterior. Probably 14th century.

Fig 83.66. Body sherd probably from polychrome baluster jug. Oxidised fabric, siltier than usual. Possibly not Colchester-type but not London-type either. All over external white slip with applied vertical strip in red body clay and unique applied ring-and-dot stamp in dark red clay. Exterior covered with green-flecked glaze. Probably 13th to 14th century, possibly copying Kingston-type ware baluster jugs in the highly decorated style (Pearce & Vince 1988, figs 50-52). Residual in Stratified Group 11.

Fig 83.67. Reduced jug sherd in early fabric. Decorated with applied vertical strip in white clay with notched or stabbed decoration imitating rouletting. Exterior covered with a greenish glaze. A sherd with identical decoration, apparently a waster, came from a post-hole fill (MID CF530) in the south-west area of Building 74, a ?potter's workshop or house on the Middleborough site. This association suggests an early to mid 13th-century date for this rare type of decoration which may be a copy of the notched strip decoration on Hedingham ware jugs. The same notched decoration is found impressed directly into the body clay of a white slipped Colchester-type ware sherd found elsewhere (CPS 190, not illustrated).

Fig 83.68. Body sherd in early fabric from the neck/shoulder area of a jug. Outer surface covered with white slip under a dark green glaze. Traces of white slip extending down from the rim area are also present on the internal surface. On the outer surface is an applied diagonal strip in red body clay with notched decoration imitating rouletting. At an angle to this, probably forming a chevron, are traces of another applied strip.

Unique, though related to no 67. Probably 13th or 14th century.

Fig 83.69. Body sherd from jug in early fabric. Lightly combed chevron decoration combed directly on to body clay under dark copper-flecked green glaze (Period 3.1). Only two other examples of Colchester-type ware with combed decoration of this sort have been recognised (including Fig 74.16), although horizontal bands of combing can occur on the necks of baluster jugs (Fig 73.11).

Fig 83.70. Rod handle from jug in coarse early fabric. Deeply slashed along axis and radially at base of handle. Traces of thick white slip decoration below handle, partially covered with clear glaze (Period 3.2). This type of handle (similar to early Fabric 20 greyware jugs) may be typical of some of the earliest Colchester-type jugs with slip decoration and is probably 13th century.

Fig 83.71. Jug or cistern handle in unglazed ?late fabric. Back of strap handle decorated with thumb impressions and stabbed circular pits. Sides decorated with thumbnail nicks. Post-medieval context but probably dates to c 1375-1450.

Fig 83.72. Handle fragment. Unglazed late fabric. Random slip decoration over stabbed circular pits. 15th to 16th century.

### Jugs and their dating

Dating for jugs as for all other Colchester-type forms depends as much on external parallels as on associated stratigraphic evidence. Although it is difficult to discuss one without the other, only the stratigraphic evidence and the bare dates suggested by parallels will be summarised here, while the nature and significance of these parallels will be considered at a later stage (see below, pp 174-7).

Around one half of all excavated jugs have some sort of slip coverage or decoration. By relating this to one of the three 'styles' of slip decoration that have been recognised on Colchester-type ware, an approximate early, middle or late dating can be assigned within the range c 1200-1550 (see pp 171-3). Form and fabric considerations may refine the dating further.

The precise forms of the earliest Colchester-type jugs (c 1200-50) are unknown, but probably included rounded jugs (eg Fig 82.50, 55) copying the early rounded and smaller rounded forms in London-type ware and Hedingham ware. These early jugs were either white slipped all over or decorated with thick slip lines, some of them copying the Rouen style of decoration from the latter industries. Large hand-made squat jugs, copying medieval greyware forms, were probably around by c 1250, some of which may have been jug-cisterns (see below pp 130 & 134, Fig 84.73). Baluster jugs were also probably in production before c 1250. Although the Rouen style could have been copied equally from Hedingham as from London, yet the idea of all over white slip must have been copied from London as Hedingham does not employ this technique, and it is unlikely that these techniques would have been copied without also copying the baluster jug form already common in London-type ware (Pearce *et al* 1985, fig 86). As there is so little definite evidence, however, for the pre-1250 Colchester-type forms, it is probably best to date the appearance of Colchester-type balusters and squat jugs from c 1250 when the general forms and even rim forms and other details come to resemble Mill Green ware, which was just beginning to circulate in Essex (see above p 182), although its main period of circulation in London was c 1270-1350 (Pearce *et al* 1982, 272).

Given the apparent rarity of Colchester-type squat jugs before c 1375/1400, it is highly likely that the majority of Colchester-type jugs up to this date were of baluster form. The following dates are suggested for specific forms of jug (for ceramic phasing of illustrated examples, where present, see Appendix 1).

### Baluster jugs

#### a. White slipped ('early style') baluster jugs

The majority are probably contemporary with the production of Mill Green ware c 1250-1350 which they much resemble, particularly those with inturned rims (Fig 71.2-6). Production of this form at Colchester may, however, have lasted somewhat longer, though on a diminishing scale, perhaps even as late as c 1400. A few smaller 'metal copy' balusters with all over slip and green glaze may have been produced perhaps as late as c 1450, together with some sgraffito-decorated jugs, but these were very minor categories. In general, white-slipped green-glazed baluster jugs ceased to be produced in Colchester-type ware after c 1400.

Closer dating, again on the basis of parallels, may be suggested for a few particular jugs. The vertical knife-trimming on the base of Figure 71.1 is a feature found on Hedingham ware stamped strip jugs c 1225-1300, although it also occurs on a later slip-painted baluster jug (Fig 74.19). The cylindrical neck, shoulder cordon and inturned rim of Figure 71.2 are closely paralleled on Mill Green ware baluster jugs with polychrome decoration. These are dated at London to c 1290-1306 (*ibid*, 292), thus suggesting a date of perhaps c 1275-1325 for similar Colchester-type forms. Figure 71.6-7 have some resemblance to tulip-necked baluster jugs in London-type ware and may similarly be dated to the late 13th and early 14th centuries (Pearce *et al* 1985, fig 37).

#### b. Baluster jugs with ('early style') applied strips or thick slip painting

Dating for these is much the same as that for the white-slipped balusters, c 1250-1350 or later. Some (as Fig 71.5) have Mill Green-style inturned rims which also suggests a contemporary date, although plain white-slip painting was more a feature of squat Mill Green jugs rather than balusters. Some Colchester-type baluster jugs with Rouen-style decoration could well be earlier than c 1250 (eg Fig 82.52-53), but unfortunately none of these has useful associations. The idea of slip-painted decoration may have developed from Rouen-style London or Hedingham copies, reinforced perhaps by the appearance of white-slip decorated jugs in London-type ware during the period c 1240-90 (Pearce *et al* 1985, fig 34, 48-9, 88), although parallels with Mill Green ware after c 1250/70 are also apparent. Colchester copies of Mill Green ware polychrome baluster jugs (Figs 73.12 & 82.56-58) may similarly be dated to c 1290-1306 (Pearce *et al* 1982, 292), or perhaps rather wider to c 1290-1325. By association with polychrome wares, the simpler linear white decoration of Figure 73.13 also shares this dating (Stratified Group 8). The form of Figure 73.14 is broadly similar to that of late 13th- and early 14th-century London-type tulip-necked baluster jugs (Pearce *et al* 1985, fig 37). Bridge-spouted baluster jugs with thick slip painting (as Fig 74.17 or unslipped as no 16) may have been inspired by Hedingham strip jugs with bridge spouts, and probably fall within the same c 1225-1300 date range.

Slip painting became thinner after c 1375/1400 and the production of baluster jugs with thin slip painting almost certainly continued after this date though the designs probably differ.

c. Baluster jugs with ('middle style') thin slip painting

These are fairly uncommon. Figure 73.15 with its fleur-de-lis decoration and slip dashes on the rim comes from a Period 3.2 context (c 1250/75-1400), but probably dates towards the end of this range, perhaps c 1375-1400 or slightly later. The other illustrated examples (Fig 74.18-19) are dated stylistically to c 1375-1450. After this date, slip-decorated baluster jugs do not seem to have been produced in Colchester-type ware, although smaller plain balusters were.

d. Late medieval 'metal copy' baluster jugs

The plain unslipped examples (Fig 74.20-23) have late associations usually with Raeren stoneware and other 15th- to 16th-century wares. Most examples, therefore, particularly those in the finer transitional fabric, probably date to c 1475-1550, though some might be slightly earlier. A few apparently 'metal copy' forms occur in the late Colchester-type fabric, some of which have earlier 15th-century associations (eg Stratified Group 10, Fig 222.19, c 1400-50). At least one example (Hurst 1961a, fig 1.2) is covered with 'early style' all over white slip under a copper-flecked green glaze. This jug occurred in a similar assemblage to Stratified Group 10. 'Metal copy' baluster jugs were the latest and smallest baluster jugs to have been produced in Colchester-type ware.

e. Miscellaneous unslipped baluster jugs

The dating evidence for these varies and has been discussed in the typology above.

Squat jugs

a. White-slipped ('early style') squat jugs

Dating evidence rests entirely on similarities with Mill Green ware squat jugs and white-slipped Colchester-type baluster jugs, ie c 1250-1350 or slightly later.

b. Squat jugs with ('early style') thick slip painting

The illustrated example (Fig 82.60) came from a Period 3.1 cess-pit on Long Wyre Street where it occurred in the same phase as Stratified Group 7, from another cess-pit, dated c 1225-75. Sherds of Figure 82.60 also occurred in the overlying cultivation layer (COC L113) in association with sherds of Colchester-type polychrome baluster jugs of c 1290-1325. A date range of c 1250-1325 thus seems likely.

c. Squat jugs with ('middle style') thin slip painting

A general date of c 1375-1450 is suggested, mainly on the basis of the 'middle style' slip decoration. There are numerous points of similarity with Stratified Groups 9 (c 1382-1421) and 10 (c 1400-50), including the cartwheel motif on Figure 75.27 (compare with Stratified Group 9, Fig 221.35-36) and the cross filler motifs on Figure 78.31-32 (compare with Stratified Group 10, Fig 224.48). Figure 75.27 is from a Period 4.1 context (c 1350/1400-1500) and Figures 75.28 and 78.31 are from a pit context similar to Stratified Group 10.

d. Squat jugs with ('late style') thin slip painting

These are associated in numerous contexts with Raeren stoneware and other late 15th- and 16th-century wares. A general date of c 1475-1550 is suggested.

Small rounded jugs

These in most cases are dated stylistically. The 'middle' or unusual 'late style' slip decoration of Figure 79.37, combined with its late fabric and general form, suggest a 15th- or early 16th-century date. The same is suggested for the

plain jug Figure 79.38, although the general form resembles 13th- to 14th-century squat greyware jugs (Fabric 20) and could be descended from these. These last two have a parallel at Hadleigh Castle dated c 1475-1525 (Drewett 1975, fig 20.182). Figure 79.39 occurs in Stratified Group 16, c 1550-1600.

'Cheam copy' jugs

There is some independent dating for these as well as the evidence of parallels. The biconical Cheam jug, of which Figure 79.45 is the most faithful copy, was first produced at Cheam around 1360 and was the prevalent Cheam jug form of the late 14th century, continuing in production until c 1440 (Pearce & Vince 1988, 86, fig 47). Cheam barrel-shaped jugs (as Fig 79.41) were produced from the early 15th century, around 1410/20, until perhaps the early 16th century (*ibid*). The Colchester-type barrel-shaped jug Figure 79.41 was found at Ardleigh, four miles north-east of Colchester, around the middle of the last century. When it was exhibited to the Society of Antiquaries in c 1856, 'it was said to have contained a small number of coins, but of which no record has been preserved; together with a deed which was exhibited, of the reign of Henry Vth' (*Proc Soc Antiqs*, 3 (1856), 98). Nothing is now known of the whereabouts of the coins or the document, but the jug is preserved in the British Museum. The Henry V document which was exhibited to the Society of Antiquaries dates this jug to c 1413-22 which coincides almost exactly with the introduction of Cheam barrel-shaped jugs to the City of London. This fact alone is quite significant in that it suggests that Colchester potters were quick to copy new styles of pottery in wide circulation around the London area.

Dating for other Cheam copies is much less precise. The barrel-shaped Figure 79.42 was associated with Raeren stoneware mugs as was Figure 79.40, suggesting a date of c 1475-1550 for their deposition. Biconical copies should logically predate the barrel-shaped copies and date from the late 14th century, but there is insufficient evidence to show this. The upper part of a biconical green-glazed jug, identical to Figure 79.45, was found in a large rubbish-pit (LWC NF27) containing a true Cheam barrel-shaped jug, fragments of Siegburg and Langerwehe stoneware jugs, some possible Raeren stoneware, and a large assemblage of 'middle' and 'late style' Colchester-type ware, suggesting a deposition date of c 1450-75. The overall impression gained is that fairly close copies of Cheam jugs were produced in Colchester-type ware soon after the introduction of the prototypes in the late 14th and early 15th centuries, but looser copies of these forms continued in production into the early 16th century. In attempting to imitate green-glazed Cheam white ware forms, Colchester-type copies perpetuated the 'early style' convention of all over white slip under green glaze which virtually all other Colchester forms had abandoned by c 1400. It is possible, however, that the very latest Cheam copy jugs may have been clear glazed (as Fig 79.40, 44) and that the few latest green-glazed copies (Fig 79.42) are slightly residual in their contexts.

Late medieval conical or cylindrical jugs

Dating associations, as well as other general characteristics, are the same as for 'metal copy' baluster jugs, ie c 1475-1550. The illustrated jug (Fig 79.46) was found in a pit with a lead alnage seal of the portcullis type, for which a date perhaps in the middle part of the reign of Henry VIII (ie

c 1530) has been suggested (CAR 5, 33, fig 37.1940). This fits with the mid 16th-century date suggested for similar forms at Braintree and Waltham Abbey (c 1540; Huggins 1986, 87-8, fig 6.12-13).

#### Miscellaneous jugs and decorated sherds

Dating evidence, where present, has been given in the typology or catalogue entry above.

#### *Jugs: function, miscellaneous markings and secondary use*

There is no definite evidence for the precise function of most Colchester-type jugs. It is reasonable to assume, however, that the majority were made for the serving and short-term storage of liquids such as wine, ale and water. The large, late medieval squat jugs would have been particularly suitable for water storage. On two 13th- to 14th-century baluster jugs (Fig 71.1 & 8), the front and base opposite the handle are slightly scorched and sooted. This has been noted on several other more fragmentary examples and suggests that the jugs were stood next to an open fire to heat the contents. This is much more evident on an unusual late medieval jug/measure (Fig 79.47) which has a heavily sooted/scorched rounded base suggesting it was placed very close to an open fire if not directly on it. In the case of the baluster jugs, the contents may have been mulled wine, toddy or ale for domestic consumption, whereas the purpose-made jug/measure might have been made for the commercial retail of similar drinks perhaps in a tavern. (Although unprovenanced, its 1899 accession date makes it very likely that it came from the site of the town hall then under construction in the High Street and adjacent to the medieval Falcon inn, later called the Cups Hotel.) Some baluster jugs (Fig 73.13 in particular) are very unstable and were probably made to stand on an earth floor.

A number of late medieval jug forms, particularly smaller forms such as the small rounded jugs (Fig 79.37-39), 'Cheam copy' jugs (Fig 79.40-45) and perhaps the 'metal copy' baluster jugs (Fig 74.20-23), might well have been used as drinking jugs. This is suggested by their approximation in size and appearance to German stoneware drinking jugs or mugs and the frequent absence of a pouring-lip. This use has been suggested for the Cheam white ware jugs (Pearce & Vince 1988, 85), and can probably be extended to their Colchester-type copies.

Deliberate markings, other than slip painting and sgraffito decoration (see below), are rare on Colchester-type jugs and other forms. Excluding occasional stabbed circular pits on late medieval jug handles, true stamped decoration occurs on only two jugs, Figure 71.5 and Figure 83.66, both 13th or 14th century. On Figure 71.5, the stamp, a quartered lozenge, occurs on the upper surface of the handle near the rim. The uniqueness of this particular stamp suggests a maker's or owner's mark. On Figure 83.66, which may not be Colchester-type ware, the applied red ring-and-dot stamp occurs on the body of a baluster jug and is probably purely decorative. Incised post-firing crosses are found on two baluster jugs. On Figure 73.11, a cross occurs on the neck of the jug behind the handle while, on a jug from the Angel Yard site, the cross occurs just above the base. A jug base from a Period 3.1 context has an incised pre-fired squiggle on the underside (COC F146). In these cases, the incised cross markings, at least, probably represent maker's or owner's marks.

Three or four Colchester ware vessels bear impressions of textiles. Two of these occur on the inside neck of large squat jugs, including Figure 78.36, suggesting that the potter's sleeve came into contact with the jug wall during some internal smoothing-off process, probably to the floor of the vessel. These impressions, and another small one on the underside of a jug or jar, are all of plain one-over-one weave. A fourth impression on the underside of a jug or jar base suggests that the vessel was placed either upon a coarsely woven straw mat or came to rest on a bundle of cord. In general, however, the undersides of vessels are normally smooth and featureless. The internal floor and angle of a thumbled baluster jug base (1.81 JL1) retains clear plant impressions. Several small leaves can be seen branching off a stem, the best preserved of these being 8 mm long with a pointed ovate or 'laurel-leaf' outline and a fine feathery internal texture. These are probably the common bracken *Pteridium aquilinum* which is also known on London-type ware (Pearce *et al* 1985, 4, pl 6) and is common on Tyler Hill ware (Canterbury). Similar, if slightly smaller leaf-impressions, are visible on the internal floor of a large 13th-century cistern (Fig 84.73).

There is one very unusual instance of a buried jug. In the hall of a medieval house at Middleborough (Building 76), a baluster jug (Fig 73.15) of late 14th- or early 15th-century style was found deliberately set into the ground directly in front of a hearth so that its rim was flush with the contemporary ground level (CAR 3, 199, fig 185B; MID EF830). The soil filling the jug was analysed by Peter Murphy and consisted of a dark reddish brown sandy clay loam containing pottery and brick/tile fragments together with bird and other small bone fragments and a mussel shell. Few conclusions could be drawn from this as the contents differed little from typical medieval and post-medieval refuse deposits (*ibid*, Appendix 14, microfiche). The pot shows no signs of wear, but has a patchy thin white deposit inside, probably the usual salts deposited by ground water. At a medieval long house at Dinna Clerks, Dartmoor, a cooking pot was found buried in front of a hearth in exactly the same position as the Middleborough jug (Moorhouse 1986, fig 13). Pots could be set into the ground for a variety of reasons (*ibid*, 115-16). In the absence of any obvious clues to its true function, one can speculate that it may have been buried for superstitious reasons. Perhaps, like many post-medieval bellarmines used as 'witch bottles', it was intended to ward off evil spirits.

#### *Jars*

This term embraces a wide variety of globular or ovoid forms including cisterns, storage jars, cooking vessels, some industrial vessels and other non-specific 'jar-shaped' forms and fragments. These forms, discussed below, comprise at least 46.5% of the Colchester-type assemblage.

#### Cisterns (Figs 84.73-78, 85.79-83, 86.84-85 & Fig 117)

Large bung-hole jars, or cisterns, whose uses included the production and storage of ale and beer, are a very common form in Colchester-type ware. They are distinguished principally by the presence of a bung-hole with an applied collar, by their lack of glaze, and their large size. Unless the bung-hole is also recovered, it is not always certain whether the vessel is a cistern, a large jug or a large storage vessel, since there is clearly some degree of overlap between these forms. The diameter range for rims of definite cisterns

is 120-300 mm with around 150 mm being the commonest. The latter figure is also the commonest diameter found in less easily classified jars and may support the impression that the majority of jars, particularly those of the late 15th and early 16th centuries, are actually cisterns.

Three basic forms of cistern occur: jug-shaped cisterns (which might just be a variant of the more common narrow-mouthed type), wide-mouthed cisterns, and narrow-mouthed cisterns.

Jug-shaped cisterns (Fig 84.73-75) are the rarest with only three or four reasonably certain examples known, including one in Colchester Museum from Wyre Street (see Fig 117, front row and Rackham 1972, pl 53). These have a squat, ovoid or barrel-shaped body with a short and narrow cylindrical neck, oval or narrow strap handles and sagging bases. None has yet been found with a jug-like pouring-lip (although the CM cistern has been reconstructed with one). The rims are beaded (Fig 84.75, and CM cistern), or thickened and flat-topped/slightly flanged (Fig 84.73), or plain with a rib or cordon below (Fig 84.74). Bung-holes are plain or slightly frilled (Fig 84.75) and at right-angles to the handle plane. However, the Colchester Museum cistern has a pronounced, almost tubular, bung-hole set at an angle of only around 30 degrees from the handle on the far side of the vessel, suggesting it was either made by, or for, a left-handed person (Fig 117). Apart from this vessel and Figure 86.84, all single-handed cisterns were made for right-handed users.

All cisterns, of whatever form, appear to have been wheel-turned except the earliest probable cistern, Figure 84.73, which was clearly hand-made and may have had a separately made base and neck which were luted on. The handle scar on this vessel appears to be that of the common deeply furrowed type (as Fig 85.83). The neck wall has been pushed-out to join the handle junction, leaving a deep cavity on the inside neck which unusually has not been plugged and smoothed over. There is no trace of glaze or decoration. These manufacturing techniques are the same as those used for Fabric 20 greyware jugs up to c 1250/75. The form is not dissimilar too, and the context does appear to be of 13th-century date (see below pp 130 & 134). It is possible therefore that Figure 84.73 could be an early Colchester-type squat jug, but as the form is unusually large and otherwise unparalleled in this fabric, it seems more likely to be a cistern despite the early date and absence of a bung-hole.

Figure 84.74, from the Magdalen Street kiln-site, is a reduced over-fired kiln-waster with exactly the same rim form and sloppy decorative details as a group of jugs, also wasters, from the same location (see p 110; Cunningham 1982a, fig 29.46-9). The exterior has patches of lustrous brown glaze. Decoration on Figure 84.75 is in the more individualistic 'middle' style and consists of a pair of roundels (one on either side) formed by an arc or near-circle of white slip enclosing a central motif of spiky foliage. Weakly defined slip dashes occur on the inside of the rim (also on Fig 84.74). Unusually, the decoration on Figure 84.75 is covered with a broad bib of green, copper-flecked glaze. The Colchester Museum cistern (Fig 117, front row) has typical 'late style' decoration (as Fig 86.85), but lacks slip dashes on the rim and, most unusually, the flat face of the bung-hole is painted white. Like most late cisterns, the latter has reduced surfaces and is completely unglazed.

All other types of cistern have barrel-shaped bodies and

sagging bases normally with groups of thumbed feet consisting of one to five impressions per group. Barrel-shaped cisterns may be divided into wide-mouthed and narrow-mouthed types.

Wide-mouthed cisterns (Fig 85.79-83) are rarer than the narrow-mouthed type, but could be represented among the numerous miscellaneous jars below (eg 87.88-9, 90-91), particularly those lacking an applied thumbed strip beneath the rim. Diameter ranges for fairly definite cistern rims in this category are about 200-300 mm. Forms are neckless and have distinctive thickened/flat-topped/squared 'cornice' rims (Fig 85.79 & 82, also on jars, eg Fig 87.86 & 88), or simpler thickened squared rims (Fig 85.83).

Figure 85.79 is the largest known Colchester-type cistern and could have a capacity in the region of 8-10 gallons. It is the only cistern with evidence for two handles, and the four groups of thumbed feet around the base have the highest number (five) of impressions per group. As with other thumbed cistern bases, the internal base/wall angle has been deliberately thickened (perhaps with an extra clay strip) to receive the thumbed impressions. The bung-hole (the only definite one associated with this type) is of plain form. Handles are of narrow strap section with multiple external grooves and a thumbed pit at the lower junction. On the upper belly of the pot is an applied thumbed spiral. Broad random splashes of white slip form a discontinuous bib on the front of the pot, but also extend over part of the handle, and a broad bib of clear glaze covers most of the decorated area. Applied thumbed spirals occur on a few other jar or cistern fragments (Fig 88.97, and sgraffito-decorated Fig 111.266). Applied thumbed rosettes (Fig 85.81) and stabbed clay discs (Fig 85.80) sometimes occur in place of spirals, though these are rare.

Simple narrow strap handles (Fig 85.82) and typically furrowed handles (Fig 85.83) are also known on this type. 'Middle style' broad slip painting occurs on the rim area of one cistern under a partial clear glaze (Fig 85.82), while typical 'late style' decoration (see below) occurs on other wide-mouthed cisterns without glaze (Fig 85.83).

Narrow-mouthed cisterns are by far the commonest type. These can have a short upright or slightly flared neck (Fig 86.84) or can be neckless (Fig 86.85). The rims are most commonly of simple flat-topped externally triangular form (Fig 86.85; see also Stratified Group 10, Fig 223.28 and Stratified Group 15, Fig 229.30), or roughly squared off (Fig 86.84). Other simple rim types including simple squared beads may also belong to cisterns (Fig 89.102-103) as well as similar jar forms. Other features of these late standard cisterns are a simple bung-hole often of flattened sub-conical profile merging with the wall of the vessel. Oval or narrow strap handles are also standard, usually with three grooves down the back and nearly always with a thumbed pit at the lower junction. Deeply furrowed handles (as Fig 85.83) also occur on this type. 'Late style' slip decoration of spiky foliage with a slip-dashed rim is almost ubiquitous. Vessels are almost invariably unglazed and most slip-decorated examples have deliberately reduced surfaces.

The context of the earliest possible cistern in Colchester-type ware (Fig 84.73) is almost certainly datable to the 13th century even if the cistern identification is in doubt. The vessel is from a pit on Culver Street Site G (a site with very little post 13th-century pottery), where it occurred with a sizable amount of other pottery unlikely to have been deposited much after c 1250-75 (ie London-type ware,



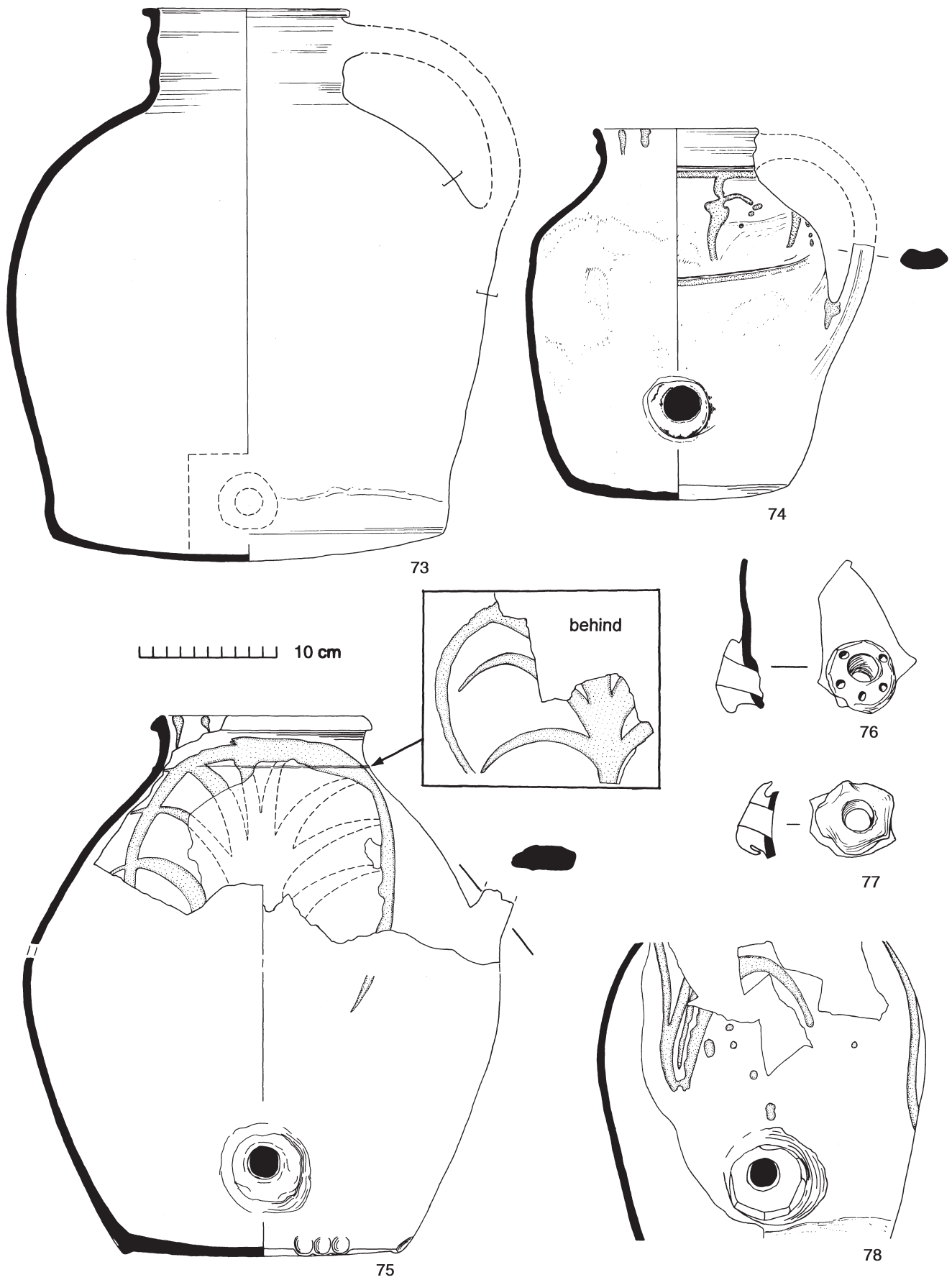

Fig 84 Colchester-type ware: jug-shaped cisterns (nos 73-75; no 74 from Magdalen Street kiln-site) and cistern bung-holes (nos 76-78). 1:4.

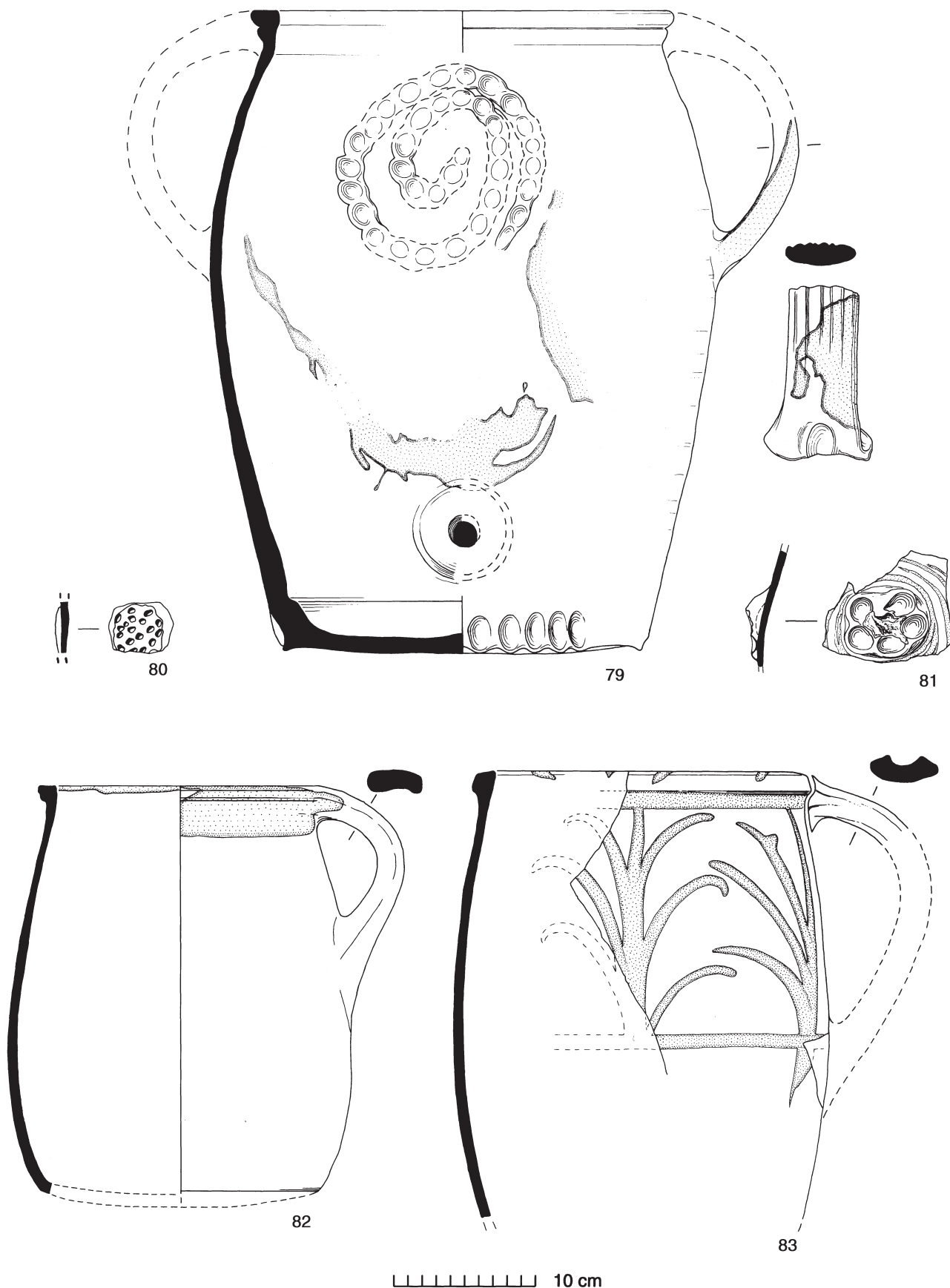
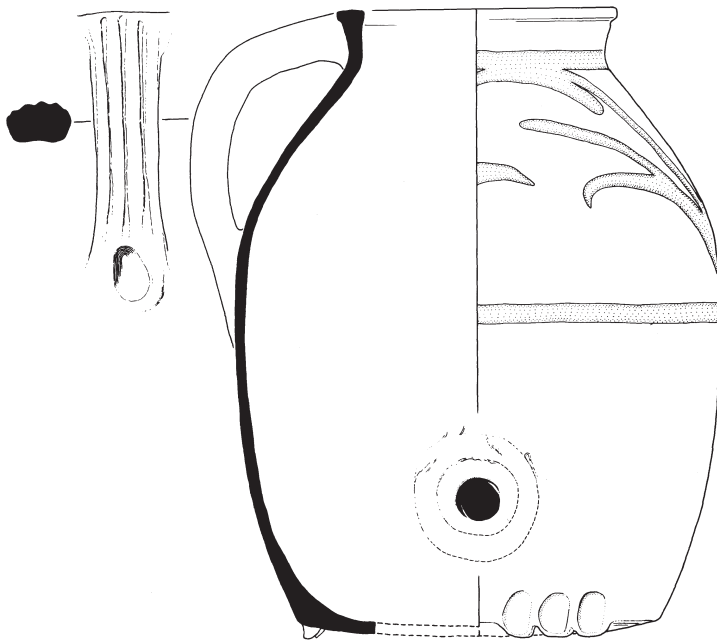
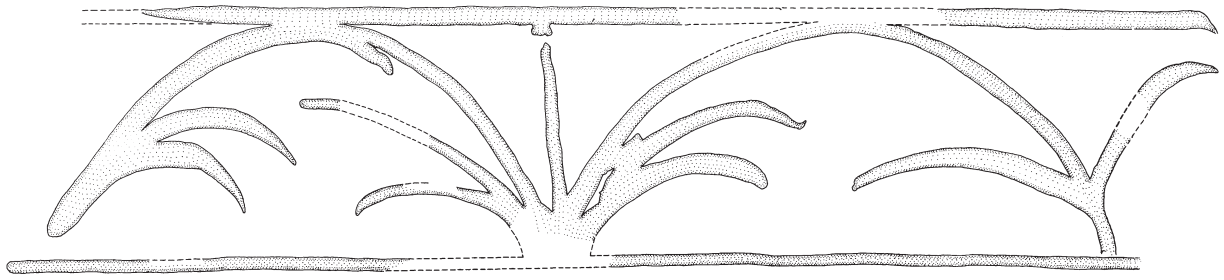
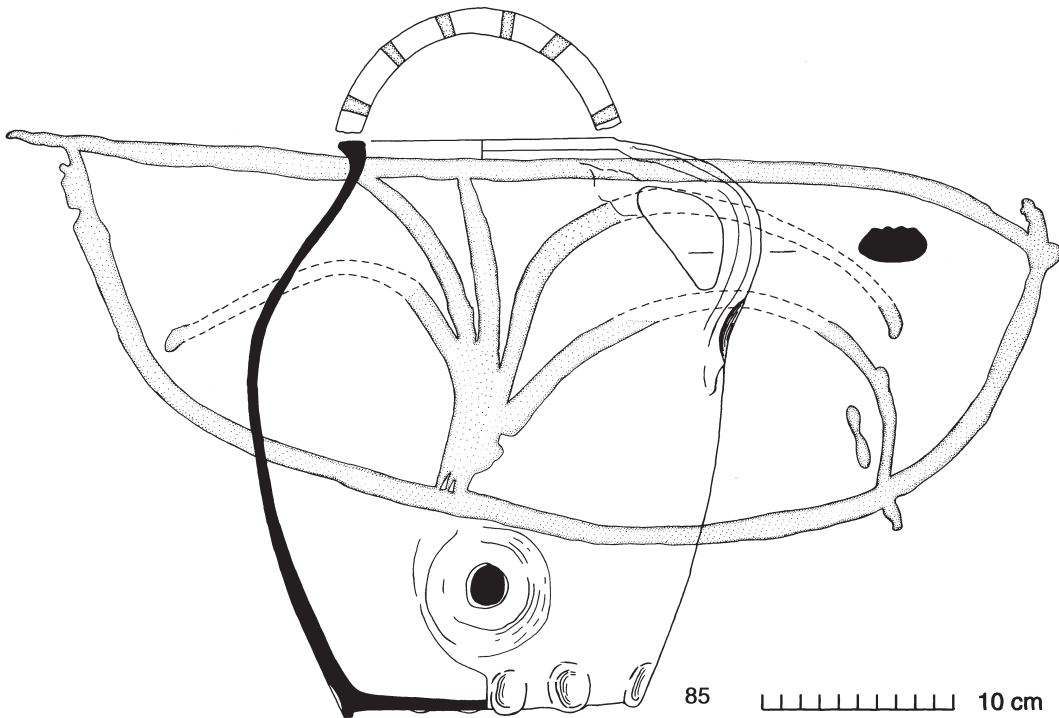

Fig 85 Colchester-type ware: wide-mouthed cisterns (nos 79, 82-83) and applied cistern 'rosettes' (nos 80-81). 1:4.



84



85

10 cm

Fig 86 Colchester-type ware: narrow-mouthed cisterns with late style slip decoration (nos 84-85). 1:4.

Hedingham ware and square-rimmed greyware cooking pots). The hand-made construction of Figure 84.73 also fits well with such a date. Identification as a cistern rests largely on its unusually large size. Although this is an unusually early date for a cistern, an even larger cistern of probable late 12th- to 13th-century date is known from Churchill, Oxfordshire (Hinton 1968, fig 17), and curiously a possible cistern bung-hole in early medieval sandy ware (Fabric 13T, Fig 32.80) was found in the same context as Figure 84.73.

The earliest definite Colchester-type cisterns are represented by bung-holes from contexts associated with the refurbishment of the town wall *c* 1382-1421 (Fig 84.77; Stratified Group 9, Fig 220.25-26). The form of these early cisterns is unknown but Figure 220.16, in the same context, could be from a wide-mouthed cistern with a simple flanged rim but without glaze or decoration. Medieval greyware cisterns also occur in the wide-mouthed form (Fabric 20, Fig 66.53-54), and this may have been copied on Colchester-type cisterns in the late 14th century. The earlier cistern bung-holes (Fig 84.76-78) were commonly thumbled or faceted and more free-standing than later types, and occasionally decorated with stabbed pits (Fig 84.76). Faceted bung-holes were the only type found at the late 14th-/early 15th-century kiln-site at Great Horkesley (Drury & Petchey 1975, fig 13.81), whereas those from the Magdalen Street kiln-site of *c* 1450 were all of the plain type (Fig 84.74). Free-standing plain bung-holes also occur in the 1382-1421 town wall contexts (Stratified Group 9, Fig 220.25), but almost all late 15th- and 16th-century cisterns have flattened plain bung-holes.

Jug-shaped and wide-mouthed cisterns may be earlier than the narrow-mouthed type, but there was almost certainly a broad period of overlap between these types. The jug-shaped green-glazed cistern Figure 84.75 was associated with a Langerwehe stoneware jug (Fig 188.9) and 'Tudor Green' ware, suggesting a date of *c* 1450. A wide-mouthed cistern with 'middle style' decoration (Fig 85.82) was associated with a Siegburg stoneware jug, suggesting a late 14th- or early 15th-century date. Despite its rather more 'middle style' characteristics, the largest wide-mouthed cistern (Fig 85.79) occurred with Raeren stoneware mugs which date it to *c* 1475-1550, though probably early in this range. The vast majority of cisterns are also dated by their association with Raeren stoneware and other late 15th- to 16th-century wares and are of the ubiquitous narrow-mouthed type with a frieze of spiky foliage (Fig 86.84-85).

Production of cisterns seems to have reached a peak in the latest phase of the Colchester-type industry, reflecting either an increase in domestic ale brewing or perhaps the translation of wooden brewing vats or barrels into ceramic form. Out of a total of 66 excavated cistern bung-holes, 8 (12%) occur in contexts broadly datable to *c* 1400-1450/75, while 33 (50%) come from contexts of *c* 1475-1550, all others coming from less secure or unstratified contexts.

Domestic ale brewing was extremely common in medieval Colchester and large numbers of 'ale wives' were annually amerced for brewing against the assize (Britnell 1986, 88-91, *passim*). In 1466 a certain John Shemyng was fined for being 'a common forestaller of earthen jars called goodale potts' (UCR 1466, 7), which are probably to be identified as cisterns (Moorhouse 1978, 7-8). Another entry in the Colchester Court Rolls for 1479 mentions '8 jars (ollas) of good wholesome ale (cervisie) containing 24 gallons as victuals for the hospice [parchment torn here] ... table ale, each of

the said jars containing 6 gallons ...' (UCR 1479, p 70). This suggests that two sizes of cistern, three and six gallons respectively, were common in late medieval Colchester.

#### Miscellaneous 'storage' jars (Figs 87.86-92, 88.93-101 & 89.102-103)

This is a very common and diverse category typified by large jars predominantly of ovoid or barrel-shaped form. Many of these are almost certainly cisterns, but as there are so few complete profiles it is not possible to say whether or not they originally possessed bung-holes. One point of difference may be the presence of an applied thumbled strip below the rim which, together with the rim proper, gives a collared look to the rim area. This feature has not yet been identified on definite Colchester-type cisterns, although thumbled spirals have (Fig 88.97), and it could perhaps signify a difference in function. Otherwise the majority of forms and their decoration corresponds closely to that of wide-mouthed cisterns with which they appear to be contemporary. Those that are not cisterns were probably storage jars of some sort, perhaps for household foodstuffs such as grain, flour or salted meat, etc.

The majority of storage jars illustrated here date, as do most cisterns, within the years *c* 1450-1550. Those with 'middle style' slip decoration, ie with a broad band of slip on the rim (Figs 87.86 & 88.96), date earlier in this period; a few might even date as early as *c* 1400. Those with 'late style' decoration, ie slip dashes on the rim combined with spiky foliage on the body, date mostly to *c* 1475-1550, as is demonstrated by the usual associations with Raeren stoneware mugs and other artefacts.

Rims are normally thickened, flat-topped or slightly flanged, and on some there is a hint of a collar below giving a 'cornice'-like profile (Figs 87.86, 88 & 88.96). A variety of other simple thickened and everted or beaded rims occur. Handles, when present, are like those of cisterns, and either of oval section, often grooved down the back (Fig 87.86, 88); or of strap section, with or without furrows (Figs 88.96 & 89.103); and in rare cases thumbled along the edges (Fig 88.96). Glaze is uncommon or absent and normally occurs as a splashed bib of clear glaze under the rim. Figure 88.97 is unusual in having an all over external olive-green glaze.

Figure 88.101 and Figure 89.102-103 are typical of a group of plain late forms, some of which have a pair of handles. These occur either in the late Colchester-type fabric, or the more silty and micaceous transitional fabric with a thin clear glaze on the upper half of the vessel and in some cases a clear glaze covering the internal vessel floor. The rim is of squared beaded form, often above a short upright neck which is often grooved. Some, like Figure 89.102, may be cisterns, but sufficient examples of the more globular double-handled form exist to demonstrate that they never had bung-holes (Fig 89.103; see also Fig 117 bottom left, CM 2.30). Dating is late 15th or more likely early to mid 16th century (see Stratified Group 15, Fig 229.26, *c* 1525-50). An almost identical jar to Figure 89.103 occurs in a mid 16th-century deposit at Braintree (Huggins 1986, fig 6.23), and a very similar form occurs at Hadleigh Castle in a context of *c* 1475-1525 (Drewett 1975, fig 21.183). The thumbled strut-like feature on the shoulder of Figure 88.101 has been observed on pottery of similar date from Canterbury.



Fig 87 Colchester-type ware: 'storage' jars (nos 86-92). 1:4.

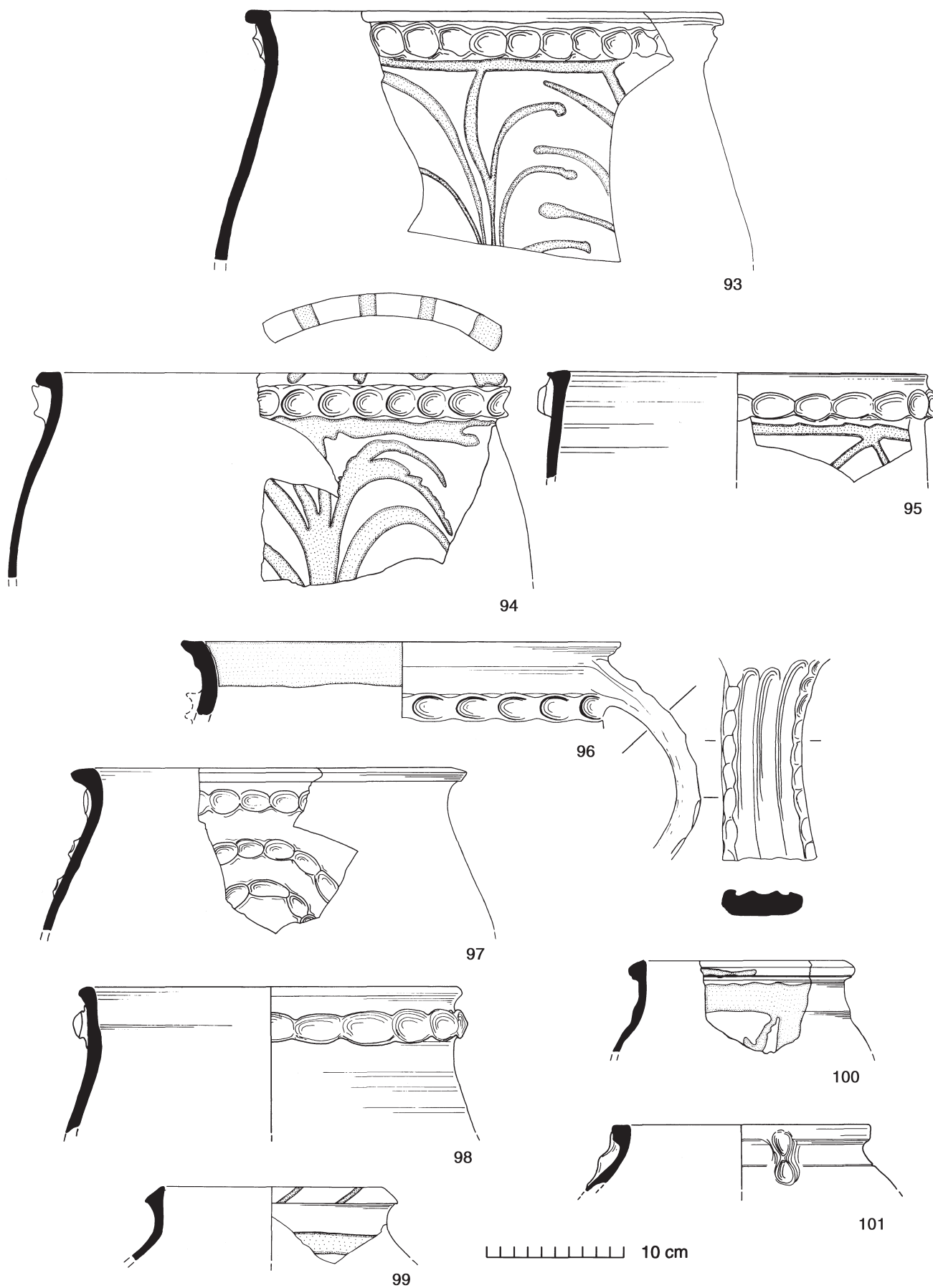

Fig 88 Colchester-type ware: 'storage' jars (nos 93-101). 1:4.

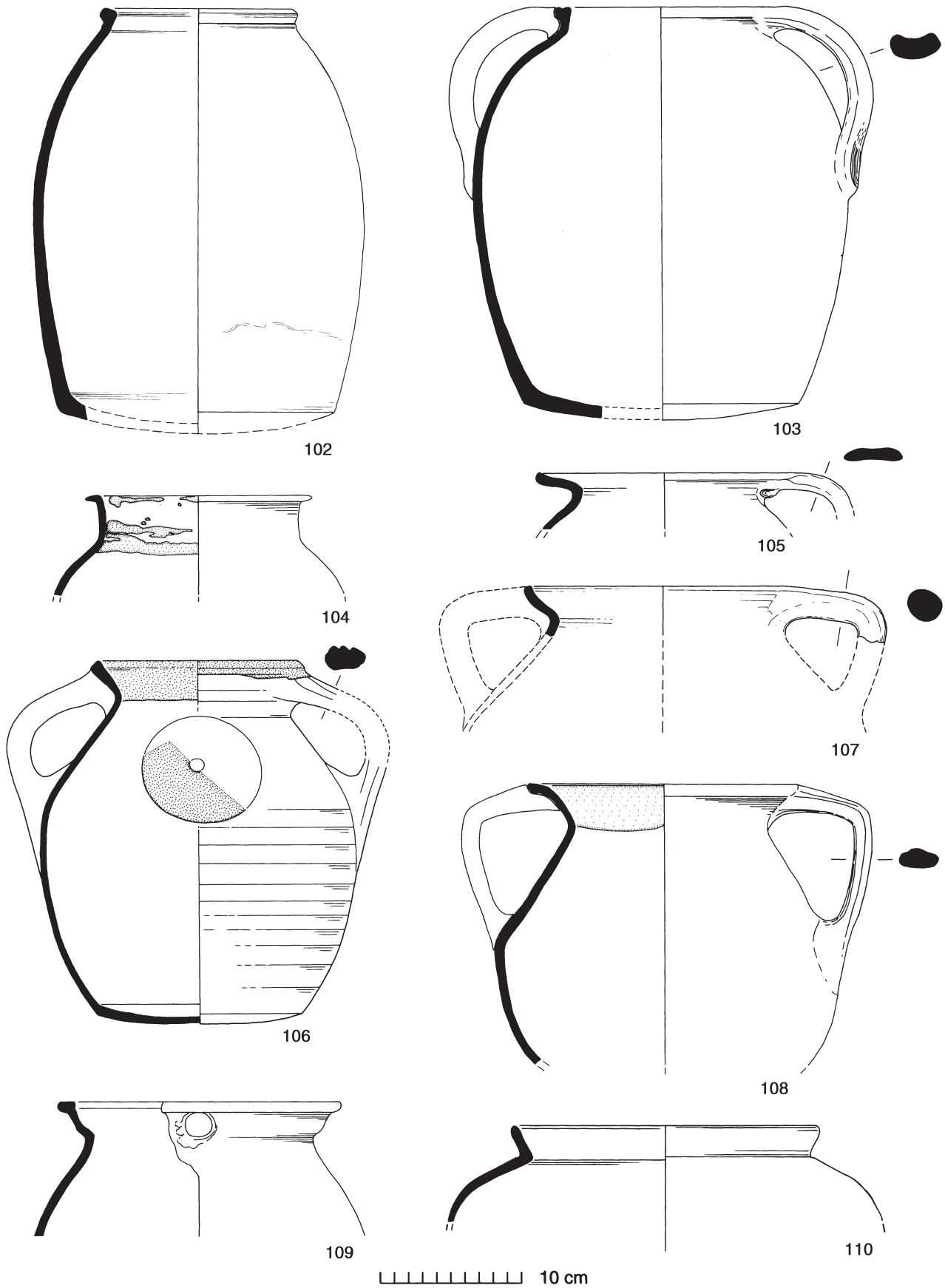

Fig 89 Colchester-type ware: 'storage' jars (nos 102-103); cooking pots or cauldrons (nos 104-110). 1:4.

*Cooking pots and related forms*

(Figs 89.104-110, 90.111-119 & 91.120-125)

There seems to be no common standard equivalent in Colchester-type ware for the large wide cooking pots found in medieval greyware (Fabric 20). It is likely that the demise of the greyware industry in the late 14th century was accelerated by the increasing availability of metal cooking vessels, and whatever gap remained at the lower end of the market was filled by a wide variety of Colchester-type cooking pots and imported redware (Fabric 31) cooking pots from the Low Countries. Compared with their greyware forerunners, Colchester-type cooking pots were generally smaller in size, more varied in shape and much less common.

Cooking pots are identified by their globular bodies, which generally have an everted rim and a sagging or flat base. Their general plainness and lack of glaze are also characteristic. In many cases the presence of sooting on the base or sides confirms their cooking function. Not all 'cooking' pots, however, conform to this description in every detail, and the many unsooted examples were not necessarily used for cooking; some could conceivably be small household storage jars and the smallest ones might have been used as serving pots/bowls or perhaps as general multi-purpose pots.

The earliest sherds of Colchester-type cooking pots occur in Period 3.1 (*c* 1150/1200-1250/75), but they are probably late in this range and few in number. Cooking pots comprise around 12% (by sherd count) of Colchester-type forms in Period 3.1 rising to approximately 30% by Period 4.2, although the latter figure includes a variety of undiagnostic jars. The form of the earliest cooking pots is difficult to reconstruct from the earliest stratified sherds, but plain globular-bodied forms with simple angled or flanged rims as Figure 89.105-110 were current (eg COC F264, MID CF545).

Typologically, cauldron-like forms are among the earliest Colchester-type cooking pots (Figs 89.104-110 & 90.111-112), though some are undoubtedly of late medieval date (Figs 89.106 & 90.111-112). Those with wide flanged or sharply everted plain rims, roughly pear-shaped bodies, and often a pair of 'elbowed' handles, seem to be ceramic imitations of metal cauldrons (Fig 89.105-110). Some (as Fig 89.108) probably had tripod feet, but other more complete examples had just a plain sagging base (Fig 89.106). White slip occurs on several pots (Fig 89.104, 107-108) usually under a clear glaze confined to the slipped area, except on no 106 which is unglazed. 'Early style' all over white slip occurs on one pot (Fig 89.105, inside and outside) and a clear copper-flecked green glaze covers the outside. A dark copper-flecked green glaze covers the inside of no 107, which occurs in a particularly coarse fabric, and there are clear glaze splashes on the inside of no 110. One pot (no 109) has a pre-firing perforation through the rim which was probably intended for the attachment of a bucket-like metal handle.

There is only limited stratigraphic dating evidence for the illustrated 'cauldrons'. Figure 89.110 is from a Period 3/4.1 context, but this can almost certainly be narrowed down to *c* 1300-75 on the basis of its association in this pit with several fragments of a medieval greyware louver, indicating a pre-1400 date (Fig 66.65-66), and part of a louver in London-type ware indicating a 14th-century date (Fig 43.6). A very similar 'cauldron' rim to that of Figure 89.108 came

from a layer in the Lion Walk ditch sequence with an associated coin and pottery date of *c* 1400 or slightly earlier (LWC NL4, see above p 112). Similar dates are suggested for Figure 89.104-105 and 107, although the latter might be a late 13th-/early 14th-century form on account of its coarseness and the rod handle. Figure 89.105 might be from the upper part of a sgraffito-decorated jug/jar as Figure 111.258, in which case a date of *c* 1375-1450 might be more appropriate. The unusual 'middle style' slip decoration on Figure 89.106 (which occurs front and back) suggests a 15th-century date, although the coarseness and late characteristics of the fabric could place it late in that century. A similar date is suggested for Figure 89.109.

Cauldrons in a very similar fabric to Colchester-type ware occur at King John's Hunting Lodge at Writtle in period I (Rahtz 1969, fig 53.31, *c* 1211-1306) and period II (*ibid*, fig 54.37, *c* 1306-1425). Similar cauldrons of *c* 1270-1350 occur in Mill Green ware (Meddens & Redknap 1992, fig 20.100).

Larger 'cauldron'-like forms as Figure 90.111-112 more closely resemble the form of earlier greyware cooking pots, but apart from this there is little other similarity. Figure 90.111 is covered internally with a greenish speckled glaze. Neither example is sooted, which leaves their function in some doubt; and Figure 90.112 is covered internally with a thick white deposit, possibly 'kettle scale' caused by water evaporation, in which case it may be related to a group of large jars with inturned rims possibly used as water containers (see below). Both examples have late 15th-/early 16th-century characteristics and associations, including typical thumbled ledge-handles on the latter example. This pot is also curious on account of its oval plan and appears to have been deformed either deliberately or accidentally during manufacture. The surface, too, is unusually pitted and flaky.

A wide variety of medium-sized cooking pots with lid-seated rims occur (Fig 90.113-119), the majority of which are of 15th- to 16th-century date, though some are earlier. It is likely that many of these would have been provided with lids, either ceramic or wooden. Some are sooted (eg Fig 90.116, 118). Most vessels are plain, but a few are clear glazed all over internally (Fig 90.115), some are glazed only on the floor internally (Fig 90.116), and a few are slip decorated (Fig 90.114, 117, 119). Handles as on Figure 90.113 are not particularly common, and this example could be classed as a pipkin rather than a standard cooking pot. The handle is deeply slashed and, at the lower junction with the wall, it is secured by five closely-spaced pulled frills, akin to the pulled feet on many late medieval vessels in Low Countries red earthenware (Fabric 31). The context appears to be early 15th century.

Perhaps the nearest one gets to a standardised, common cooking pot in Colchester-type ware is the globular form represented by Figure 90.116. These are commonly lid-seated, though a variety of plainer hollow flanged and down-turned flanged rims can occur (Stratified Group 10, Fig 223.35-39). This form was probably in circulation from *c* 1400 until the end of Colchester-type ware production. It occurs in Stratified Group 10 (*c* 1400-50) and many other contexts of this date, and the lid-seated form becomes increasingly common in the period *c* 1475-1550. Figure 90.116 was found complete in a pit in Wyre Street *c* 1930 where it was associated with two other late Colchester-type forms, a late jug-shaped cistern and a double-handled storage jar, all suggestive of a late 15th-/early 16th-century



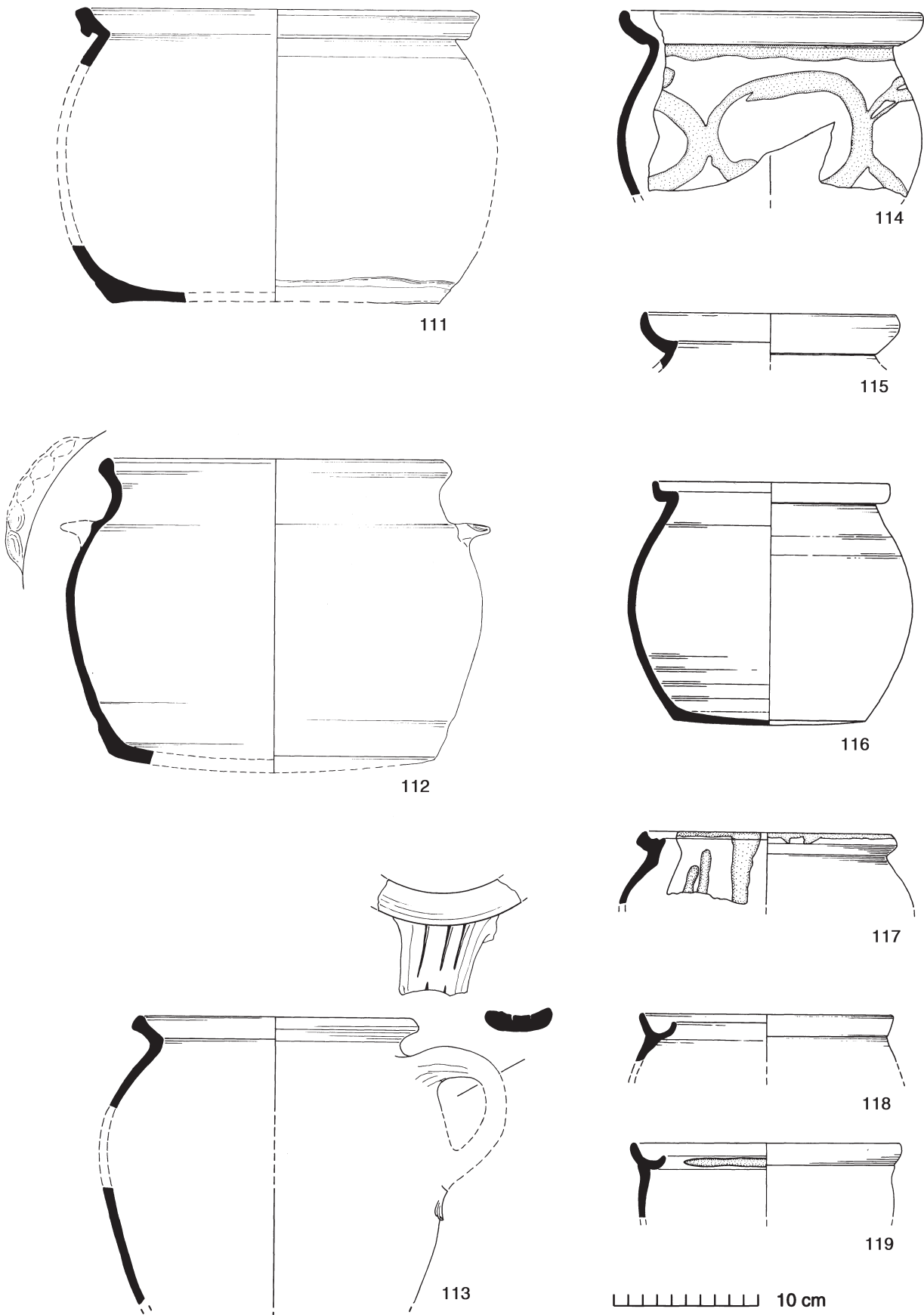

Fig 90 Colchester-type ware: cooking pots (nos 111-119). 1:4.

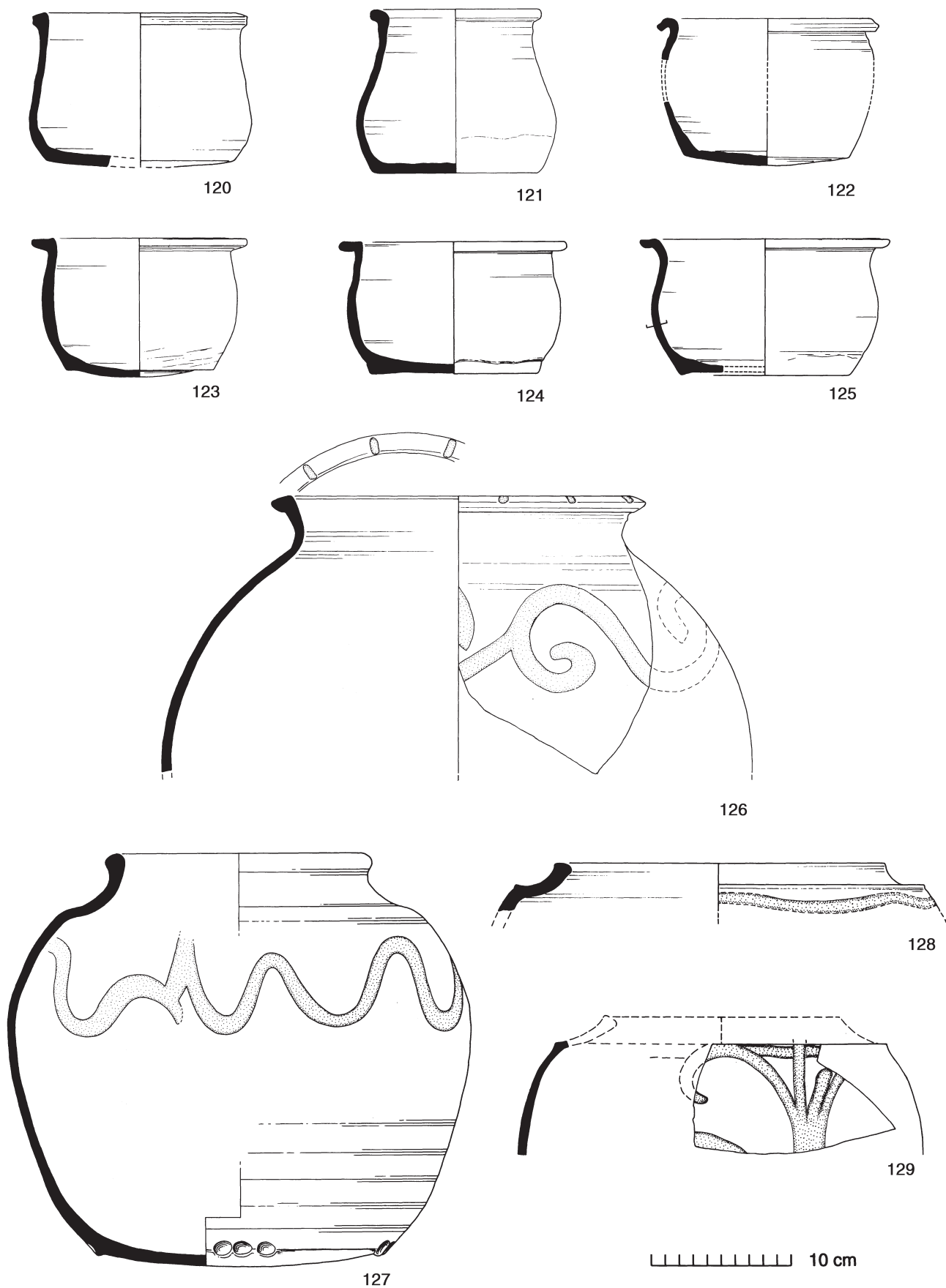

Fig 91 Colchester-type ware: cooking pots (nos 120-125); jars with external lid-seating and related forms (nos 126-129). 1:4.

date (Fig 117, bottom left). A very similar but larger cooking pot of this form occurs in a mid 16th-century deposit at Braintree (Huggins 1986, fig 7.28). The other lid-seated jars illustrated (Fig 90.114-115, 117) also have late dating associations. Despite its unusual 'middle style' decoration of slip-painted hoops, Figure 90.114 has an identical form parallel in Stratified Group 14 of c 1525.

A minor but distinctive class of small-medium cooking pots has markedly bifid lid-seated rims (Fig 90.118-119). These might have had an industrial function, as they resemble some undoubted industrial vessels in this fabric which also have bifid rims (Fig 105.238-239, *see below*); or they may have served some specialised cooking function. Dating for this class seems relatively early. One example was associated with a late 14th-/early 15th-century assemblage (LWC BF46, *see above* p 112). Another (Fig 90.118) was associated with a Langerwehe stoneware jug (Fig 188.2) and an Utrecht-style curfew (Fig 182.33), suggesting an early to mid 15th-century date.

Small cooking pots are quite common and exhibit some standardisation (Fig 91.120-125). The body is most commonly squat or globular with a flat or sagging base and a horizontal flanged rim. Downturned rims are also common (Fig 91.122), and a variety of thickened everted rim forms are known which are perhaps more associated with an upwardly tapering body (Fig 91.120-121). Apart from odd splashes, all examples are unglazed and quite plain. Sooting occurs on some (eg Fig 91.124).

Small Colchester-type cooking pots (Fig 91.120-125) were either copied from the form of mid/late 14th-century greyware cooking pots or *vice versa*. The Colchester-type form is common from the end of the 14th century onwards, though it is rather more common in the period c 1375-1475, perhaps, than in the last 75 or so years of the industry. Examples occur in town-wall refurbishment contexts of c 1382-1421 (Stratified Group 9, Fig 220.13-14) and in Stratified Group 10, c 1400-50 (Fig 223.32-34). Figure 91.125 comes from a cess-pit that also produced a complete Saintonge *pégau* and other wares of c 1400-25. Small cooking pots were produced at the Magdalen Street kiln-site c 1450 (Fig 90.121, a waster or second), including more globular types with a neck (Cunningham 1982a, fig 29.50). The latest examples including Figure 91.120 (c 1475-1550) may exhibit a move away from the earlier flanged rim towards more simple rim forms (cf cistern Fig 85.83).

#### *Jars with external lid-seating and related forms* (Figs 91.126-129 & 92.130-132)

Jars with external lid-seating are a distinctive late medieval Colchester-type form. Most examples are fairly large with a markedly globular body with an angled shoulder, and an inturned thickened rim with a concave upper/outer surface providing an external lid-seating. The only complete profile (Fig 91.127) has a wide sagging base with groups of thumb-ed feet. This is a moderately common vessel form at Colchester. At least 35 such vessels have been identified. Rim diameters (measured from the external thickened lip) range from 140 to 260 mm across with around 180 mm being the commonest. Most examples are completely unglazed or have just a few glaze specks, except for a handled example (Fig 92.130) which is covered externally with a thin clear glaze. A few examples are decorated with thin white slip (Fig 91.127-129).

The precise function of these vessels is uncertain, but as only one example is sooted it is unlikely that cooking was their main function. There is a general similarity with other externally lid-seated forms elsewhere which have been identified as pottery distilling bases or industrial bases (Moorhouse 1972, fig 32), and at least one of the Colchester jars almost certainly served an industrial function (Fig 92.132; Stephen Moorhouse, *pers comm*, 1985). This identification is suggested by the unusually thick walls and relatively crude production of this vessel, also by its unusually flaky discoloured external surfaces, possibly caused by extreme heat, but without sooting. The unabraded interior is darker and redder towards the base. Externally the fraction of surviving base shows an applied feature, possibly a bung-hole or a tripod foot. The vessel occurred alone in a pit sealed by a 16th- or 17th-century wall associated with a medieval building (Building 29) on Lion Walk Site D. Other industrial vessels are discussed below (*see* p 156).

The identification of industrial jars as distinct from more domestic vessels depends very much on the context, associations and characteristics of the vessel in question, and it is likely that the majority of externally lid-seated jars at Colchester served a more domestic purpose (Stephen Moorhouse, *pers comm*). The frequency of this vessel form in the surrounding region (*see below*) also makes it unlikely that they were all made for industrial purposes. As Figure 92.132 has a noticeably squarer outline compared to the other jars, this could be a feature of its industrial function.

Most of the jars are curiously pitted externally, and one example is worn externally below the lip, perhaps by a lid. Several jars, including Figure 91.127 and the large globular jar Figure 91.126, have an internal white deposit which reacts with dilute hydrochloric acid, indicating the presence of calcium carbonate. This is probably to be identified as 'kettle scale' resulting from the evaporation of water. Many complete Roman vessels at Colchester show the same deposit and evaporation lines caused by the area's particularly hard water supply. It is suggested therefore that most externally lid-seated jars at Colchester may have served as domestic water containers, perhaps for drinking water, or for the washing of hands, or for various other household needs. This interpretation could be extended to include other large globular jars with white deposits such as Figure 91.126 and the handled form Figure 90.112. The similarity between the small handled form Figure 92.130 and late medieval metal lavabos (for hand washing) has also been noted (Stephen Moorhouse, *pers comm*).

Jars with external lid-seating, as at Colchester, are a fairly common late medieval vessel form in East Anglia and the east Midlands. Most of the examples known to the author occur in the Northamptonshire-Huntingdon-Cambridgeshire area. Outside Colchester they are uncommon in Essex, which suggests that Colchester potters were influenced by late medieval pottery industries to the north-west.

Jars of this type were produced in East Midlands Reduced Ware at the Flitwick kiln-site in Bedfordshire, c 1375-1500 (Mynard *et al* 1983, fig 3.25). They were also produced at Glapthorn, Northamptonshire in the later 15th century (Johnston *et al* 1997, fig 10.11) and at Brill, Buckinghamshire within the period c 1470-1550 (Hurman 1988, fig 8.8-9). A complete vessel from Hartford, near Huntingdon, contained a coin hoard dated to c 1507 (Dickinson & Cherry 1965, fig 1). Two remarkable sgraffito-decorated jars of

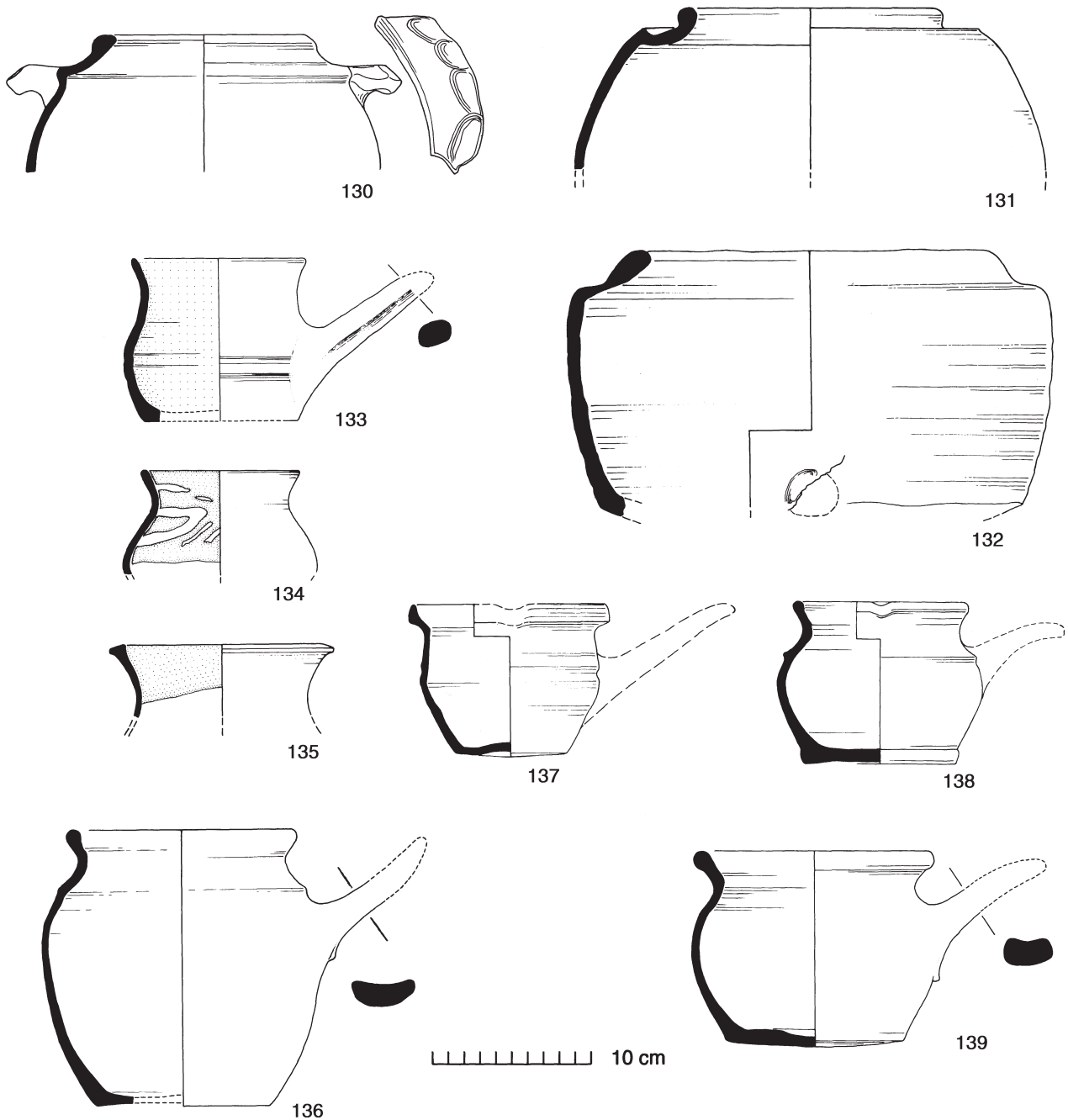

Fig 92 Colchester-type ware: jars with external lid-seating (nos 130-132; no 132 industrial vessel); pipkins (nos 133-139). 1:4.

similar form, probably of late 14th- or 15th-century date, are known from Trinity Hall and Trinity College, Cambridge (Bushnell & Hurst 1953, fig 7 and pl VII). The latter have pairs of upright lugs pierced for suspension which, in one case, are decorated with incised grotesque faces. One of the Cambridge jars had a tubular spout (broken off) projecting from the side. The analogy with metal lavabos is again very obvious. (See chafing dishes, pp 150-4.)

The Colchester jars have predominantly 15th- to 16th-century dating associations. The earliest possible example comes from a town wall refurbishment context of c 1382-1421 (Stratified Group 9, Fig 220.15). A further example came from a context of c 1400 or slightly earlier in the Lion Walk ditch sequence (LWC NL4, see p 112). Examples occur in Stratified Group 10, c 1400-50 (Fig 223.40-41) and many late 15th-/early 16th-century contexts. The large

globular jar with 'middle style' slip decoration (Fig 91.126) occurred with Figure 90.118 (above), suggesting an early to mid 15th-century date. The handled form (Fig 92.130) occurs in a late transitional fabric and could be as late as c 1550. A jar with external lid-seating from Hadleigh Castle, Essex came from the foundation trench of the phase III hall which is dated c 1300 (Drewett 1975, fig 17.83), which, if correct, would make it the earliest known example of this form. After the decline of the Colchester-type pottery industry, c 1550, this form disappears completely.

#### *Pipkins and skillets* (Figs 92.133-139 & 93.140-144)

The earliest recognisable pipkin in this fabric (Fig 92.133, Period 4.1), probably dates to c 1400-25 as it was found in the same cess-pit as an almost whole Saintonge *pégau* (Fig 174.7). The interior of the pipkin is covered with white slip under a green, copper-flecked glaze. The unglazed exterior is heavily sooted and there is a thick carbonised deposit inside. Less than a fifth of the base survives, but a much smaller whole example in Colchester Museum proves that the base was plain and flat (Fig 116, top; CM 932.1905). Figure 92.134, with partial internal slip and a clear glaze, has a similar simple profile and may be a little residual in its context of c 1475-1525 (Stratified Group 12). Figure 92.135 is covered with an all over external and partial internal white slip with an external bib of green glaze. It was found with the slip-decorated jar Figure 91.126 and has the same early to mid 15th-century dating associations (see above).

Many pipkins have an internal covering, or at least a splash, of clear glaze. There does not appear to be much chronological distinction between flat- or sagging-based and tripod-footed pipkins, though the flat bases and shoulder cordons of some examples (ie Fig 92.136, 138) have a distinctly post-medieval character and probably continue well into the 16th century. The flat dimpled base of Figure 92.137 is characteristic of early 16th-century vessel forms in the transitional fabric. With the exception of Figure 92.133 and Figure 93.140, the attachment of obliquely-angled handles and tripod feet to the body of the vessel normally created a deeply thumbed pit at the external junction, a common feature of later 15th- to 16th-century pipkins.

Decoration other than white slip is uncommon. Horizontal grooves occur on Figure 92.133 and a band of horizontal combing occurs on Figure 93.140. The latter with its 'middle style' painted rim and slip-splashed interior is the nearest any pipkin gets to slip-painted decoration and probably dates to the middle of the 15th century.

Pipkins were effectively small cooking pots, probably used to prepare sauces or to separately cook certain ingredients of a meal, or, perhaps, to keep small portions warm. Most are sooted from use. One pipkin (form as Fig 92.138), with a heavily scorched base, contains deposits of a pinkish-red pigment, perhaps mercuric sulphide in the form of cinnabar, suggesting use as a paint-pot. Pipkins are moderately common in assemblages of late Colchester-type ware.

Ladles or skillets, ie small handled dishes (Fig 93.143-144), are quite rare. These were also used to prepare sauces, etc and perhaps for serving too. The three known examples are clear-glazed inside. Sagging bases occur on two examples of c 1475-1525 (Fig 93.144; and, with thumbed base, Cunningham 1982a, fig 32.88). Figure 93.143, in the transitional fabric, has a flat base on tripod feet and comes from a context with Cologne stoneware of c 1525-50.

## **Bowls**

This term covers a variety of dish and bowl-like forms, both small and large, which collectively comprise 18.5% of the Colchester-type assemblage.

#### Dishes, small bowls and condiments (Figs 93.145-151 & 94.152-153)

This is a minor category, not clearly divorced from bowls in general, but clearly different from the great bulk of wide, deep bowls or 'pancheons' with flanged rims (see below for metrical data). This includes a possible frying pan (Fig 94.153) which, though unsooted and lacking a handle, seems to be inspired by late medieval examples in Low Countries red earthenware. Figure 94.152 (15th century) could have had a similar use, or could perhaps be a large condiment. Figure 93.151 is unique in form and despite its resemblance to post-medieval dishes, an internal covering of white slip under a green copper-flecked glaze suggests a medieval date, perhaps late 14th to early 15th century. Small, straight-sided bowls (Fig 93.145-150) with simple rims, sometimes clear glazed inside or, in rare cases, slipped and glazed (Stratified Group 11, Fig 225.7), are likely to be condiments. Some, as Figure 93.146 (Period 3.2), which is complete, are clearly individual vessels and were neatly made and trimmed-off, whereas other, somewhat cruder ones (Fig 93.148-149) were luted together in groups of two or three. The date range for Colchester-type condiments is from the early 14th to at least the late 15th century.

#### Large bowls or pancheons (Figs 94.154-160, 95, 96.161-166, 97.167-173 & 98.174-180)

With some exceptions, bowls in Colchester-type ware are wide, deep vessels with straight or slightly curved flaring walls, sagging bases, and external flanged rims. These may be described as 'pancheons'. The commonest single rim form (17.5%) is a broad, hollowed, obliquely angled flange, usually underscored to mark it off from the vessel wall (Fig 96.164-166). Groups of thumbed feet are sometimes associated with bowls having this rim form. Next, and of equal importance (both around 15%), are down-turned and horizontal flanged rims (Fig 96.162, Fig 97.167-168, Fig 94.155-156, 158 & Fig 96.161). Closely related, particularly to down-turned rims, is a class of near-bifid, almost hammer-headed rims (7.5%), with varying degrees of development into an upper inner lip and a lower flange, similar to Roman flanged bowls but much less clearly defined (Fig 97.169-172). Apart from plain, or underscored, obliquely flanged rims (6.6%; Fig 96.163), most of the remaining rim types individually account for less than 5% of all bowl or dish rims.

Diameter ranges for bowls, including dishes and possible condiments (see above), are between 110 and 640 mm. Those with the smallest diameters, generally under 200 mm, tend to have the simplest rims and fall within the dish/condiment category, constituting around 18% of all bowl forms (or around 2.7% of all vessel forms, although these figures are exaggerated by the tendency of smaller vessels to break into fewer sherds). Large bowls or pancheons fall between 190 and 640 mm with a fairly clear peak between 350 and 400 mm.

The earliest bowl identified in this fabric is a small sherd with a simple hollow flanged rim (similar to Fig 98.174) from a

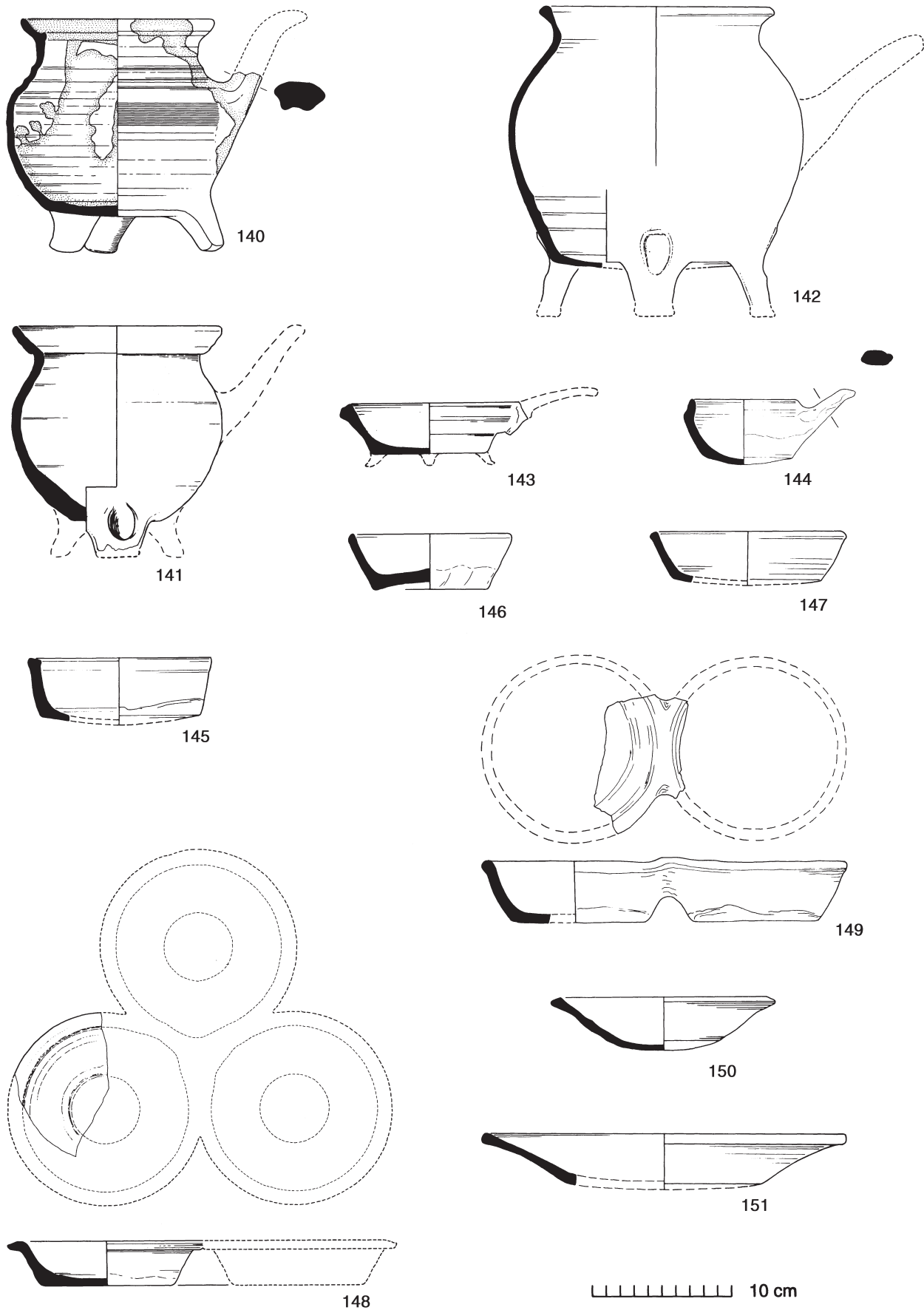

Fig 93 Colchester-type ware: tripod pipkins (nos 140-142); skilletlets (nos 143-144); small dishes or condiments (nos 145-151). 1:4.

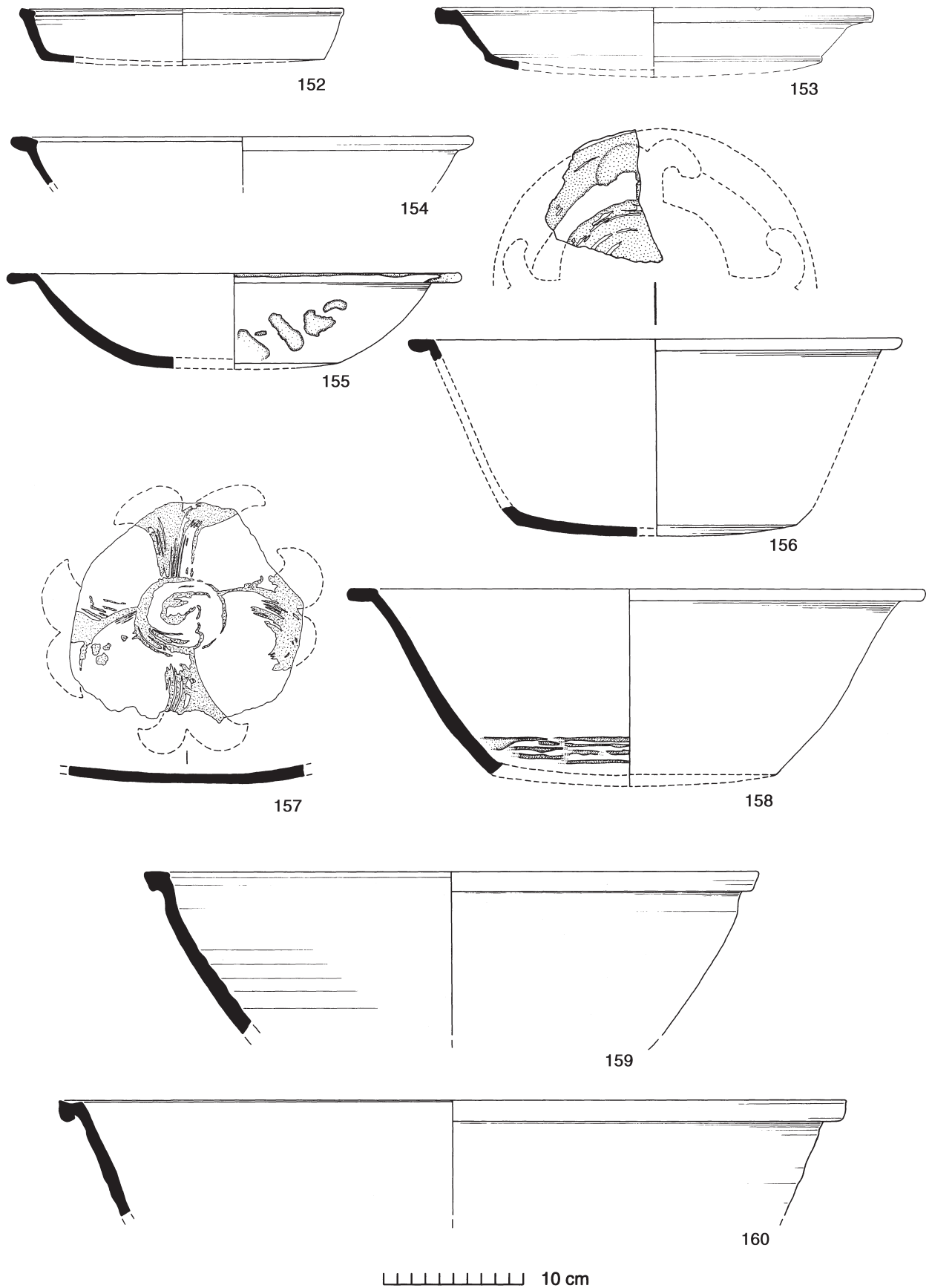

Fig 94 Colchester-type ware: small dishes or ?frying pans (nos 152-153); large bowls or pancheons (nos 154-160; no 155 with all over internal slip and nos 156-158 with internal slip decoration). 1:4.

Period 3.1 lime kiln (LWC JF16). It was associated with sherds of Scarborough (Phase I) ware, the base of a London-type baluster jug and several Heddingham ware jugs, including a combed sherd, all suggestive of a deposition date between *c* 1250 and 1300. There is a very unusual early Colchester-type bowl from a pit at Gutteridge Hall at Weeley, eight miles east of Colchester. This is fairly small with a diameter of around 260 mm and straight flaring sides with a thickened flat-topped or short flanged rim similar to Figure 94.154. The bowl is covered all over (including the underside) with an irregular white slip under an apple-green copper-flecked glaze. In the same pit were sherds of neckless greyware (Fabric 20) cooking pots and a sherd from a Saintonge polychrome jug suggesting a deposition date in the early 14th century (Walker forthcoming (b)). Bowls, however, remain fairly rare in the 14th and early 15th centuries.

It is not until the last and most prolific century of Colchester-type ware production, roughly from the mid 15th to the mid 16th century, that bowls are present in great quantity. Large bowls or pancheons remain basically similar in shape throughout their production period. Closer inspection, however, does reveal some chronological development. The scarcity of these bowls in the 14th century may be explained by the presence of bowls in medieval greyware (Fabric 20). Colchester-type ware bowls at first appear to reflect the limited variety of fairly simple, narrow flanged rims (angled, horizontal and down-turned) occurring on late greyware bowls (Fig 94.154, Stratified Group 9, *c* 1382-1421; Fig 94.156, 158). The basket-like handles of Figure 98.174 are possibly in imitation of Mile End-type greyware bowls (see Fig 61.31). This handled example is one of the earliest known Colchester-type bowls, part of which was found in a Period 3.2 context stratified with Colchester-type polychrome jug sherds of *c* 1290-1325 or thereabouts (see p 127). The underscoring of flanged rims is a feature that occurs in increasing prominence on bowls and jars from at least the late 14th century.

Painted slip decoration is rare on bowls and appears to be confined to the earlier examples, those of the 14th and early 15th centuries (Fig 94.156-158). Less than a dozen examples are known, mostly fragmentary unintelligible designs. On two or three examples (Fig 94.156-157 & Fig 95),

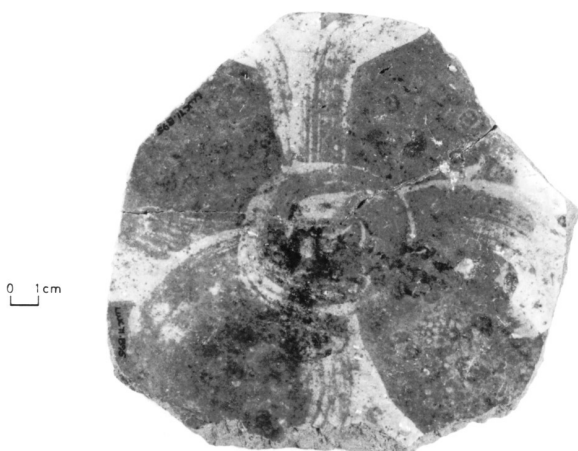

Fig 95 Colchester-type ware: bowl interior/floor with slip decoration under clear glaze (no 157), *c* 1350-1450.

however, the floor is clearly painted with a loosely drawn cross with bifid or foliate terminals and then covered with a clear glaze. Figure 94.156 (LWC NL4), from the Lion Walk ditch, occurs in a context of *c* 1400 or slightly earlier (see above p 112). Spots and splashes of white slip occurring on later bowls appear to be accidental. 'Middle style' slip painting occurs on a bowl from the 1986-7 Angel Yard site (40.86 L212, not illustrated) in the form of white slip all over the upper surface of the flange and partly inside. Slip dashes on the rim, so characteristic of later jars, have been noted (or are accidental) on the rim of only one atypical bowl from the excavations covered by this volume (Fig 98.179, Stratified Group 9), although they definitely occur on a flanged bowl from Osborne Street (588.AL65) and on another bowl from in Colchester Museum (CM 8.61). Generally, however, decoration of bowl rims is extremely rare.

An unusual lid-seated bowl (Fig 98.180) is covered internally with underglaze white slip and is sooted externally. This piece, clearly residual in a 17th-century context, is probably 14th or early 15th century. More problematical is an all over internally slipped and glazed bowl (Fig 94.155, Stratified Group 14), which occurs in a good context of *c* 1525. The flanged rim is fairly simple and it may be residual, but if not, then it is an unusually late survival of a technique that generally disappeared around a century earlier.

Curiously, it is the early slip-decorated bowls and the basket-handled bowl that display considerable external sooting, suggesting their use as cooking vessels. Such sooting is comparatively rare on later bowls. If this observation is correct, it may suggest that an earlier function as cooking vessels was replaced by a later food preparation/storage function.

A fairly distinctive bowl rim is illustrated as Figure 96.162 (from a context of the mid 15th century). This has a slight bead at the end of the flange and often a slight bead behind the internal angle, both sometimes created by scored lines. The earliest such example occurs in Period 3.2 (MSC L15), and their occurrence appears to be consistent with the 'middle' period of Colchester-type ware production, roughly from the late 14th to the mid 15th century. This type of rim is found on two almost complete bowls recovered in 1907, from the probable kiln-site at Magdalen Street (see above p 110).

The two commonest types of bowl found may now be considered as type-fossils of the late 15th- to mid 16th-century Colchester-type ware industry (Fig 96.164-166 & Fig 97.169-171, and similar forms). Their occurrence is virtually synchronous with the widespread use and disposal of Raeren stoneware drinking mugs of this date. Although hollowed, flanged and even slightly underscoring rims may occur from as early as the 14th century, these tend to be quite narrow and poorly defined in contrast to the distinctive broad, hollowed and sharply underscoring rims of the later bowls (Fig 96.164-166). These more pronounced rims make their appearance in the second half of the 15th century. Clear glaze, even more so than on earlier bowls, is strictly confined to the floor of the vessel. Thumbled feet may also be a distinguishing feature of broadly flanged bowls.

From bowls with horizontal and down-turned flanges emerges the second distinctive type of late bowl, with a near-bifid or 'hammer head' rim. This development can be traced through bowls like Figure 97.167-168 through to Figure 97.169-171



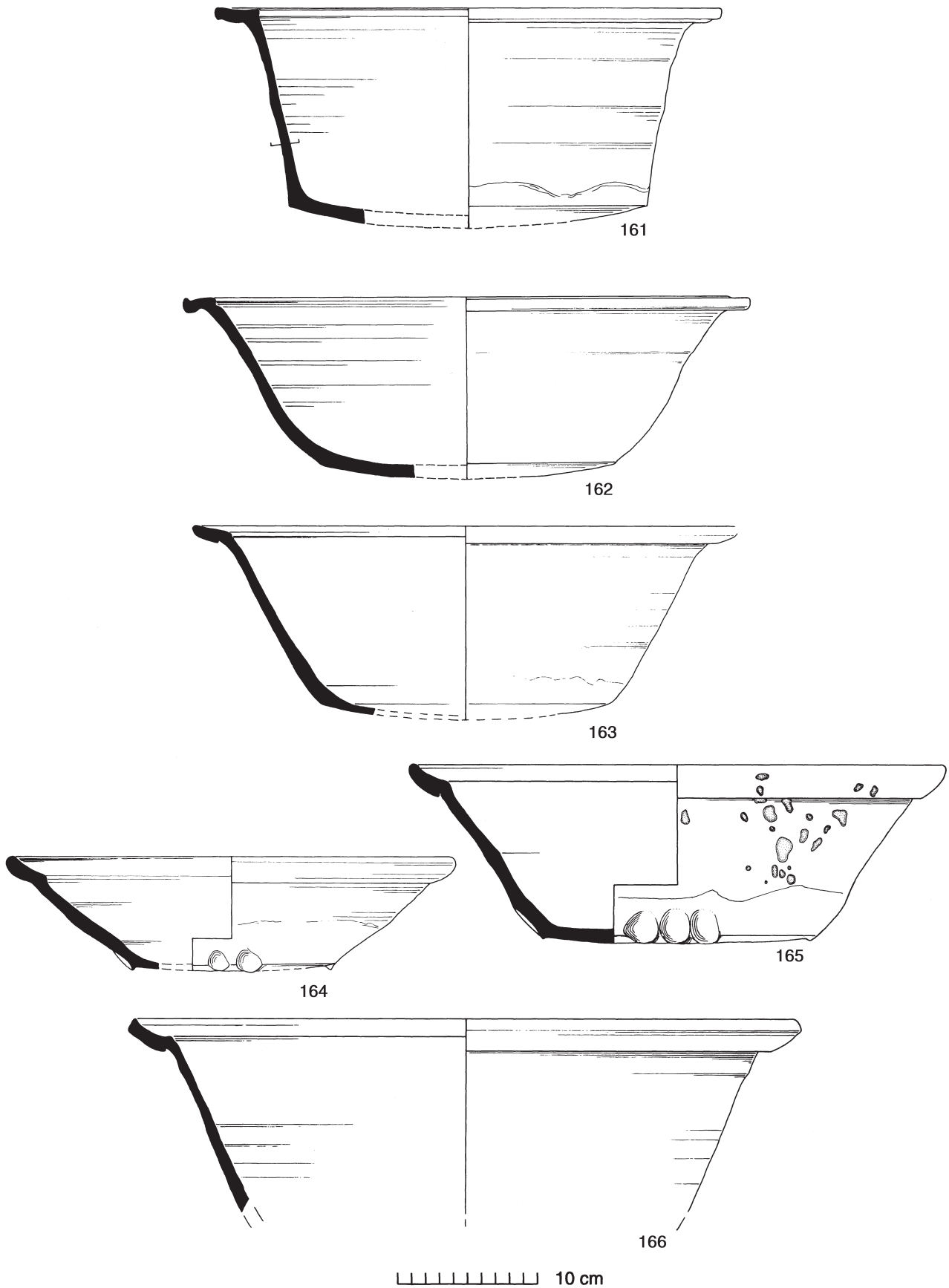

Fig 96 Colchester-type ware: large bowls or pancheons (nos 161-166). 1:4.

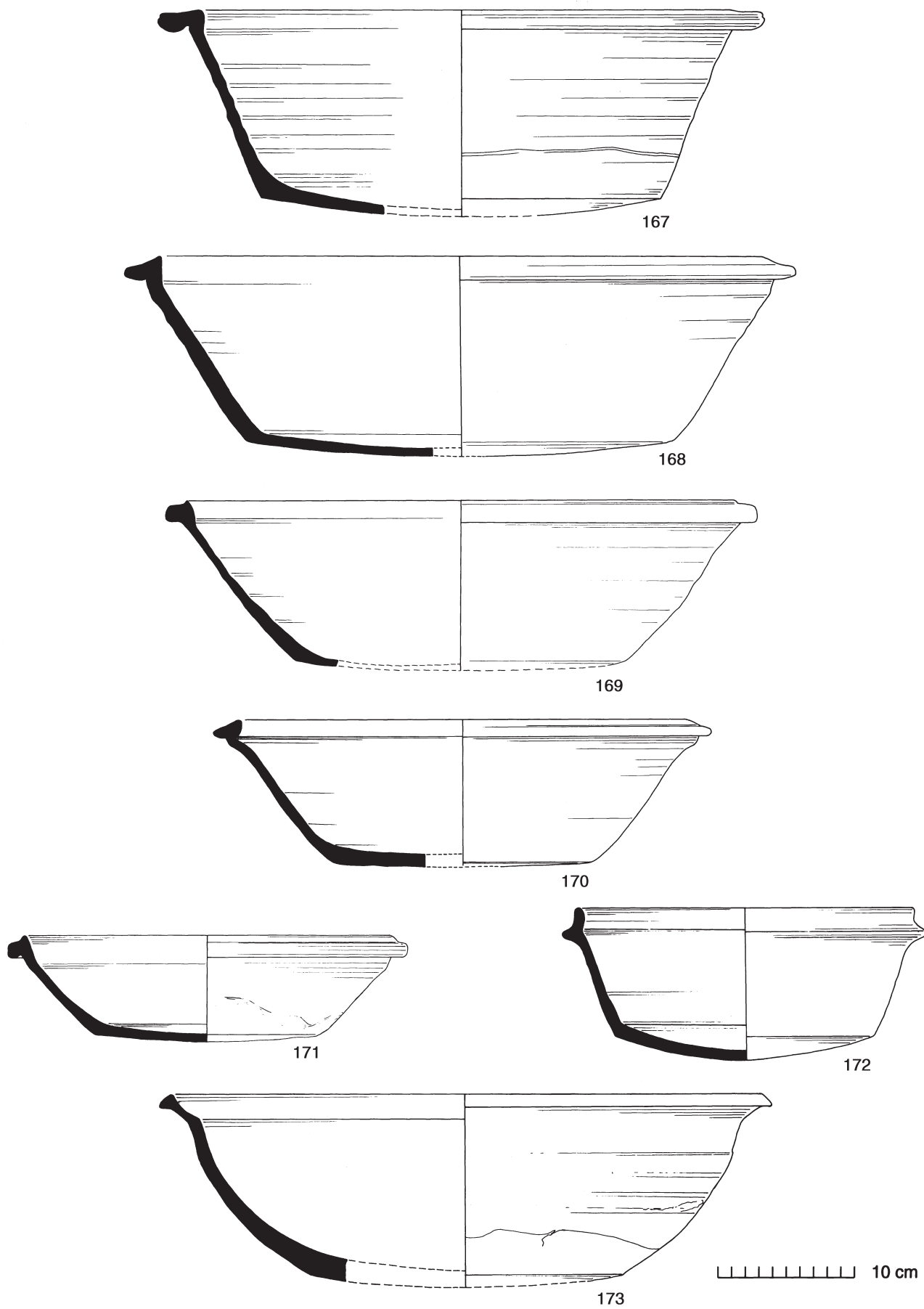

Fig 97 Colchester-type ware: large bowls or pancheons (nos 167-173). 1:4.

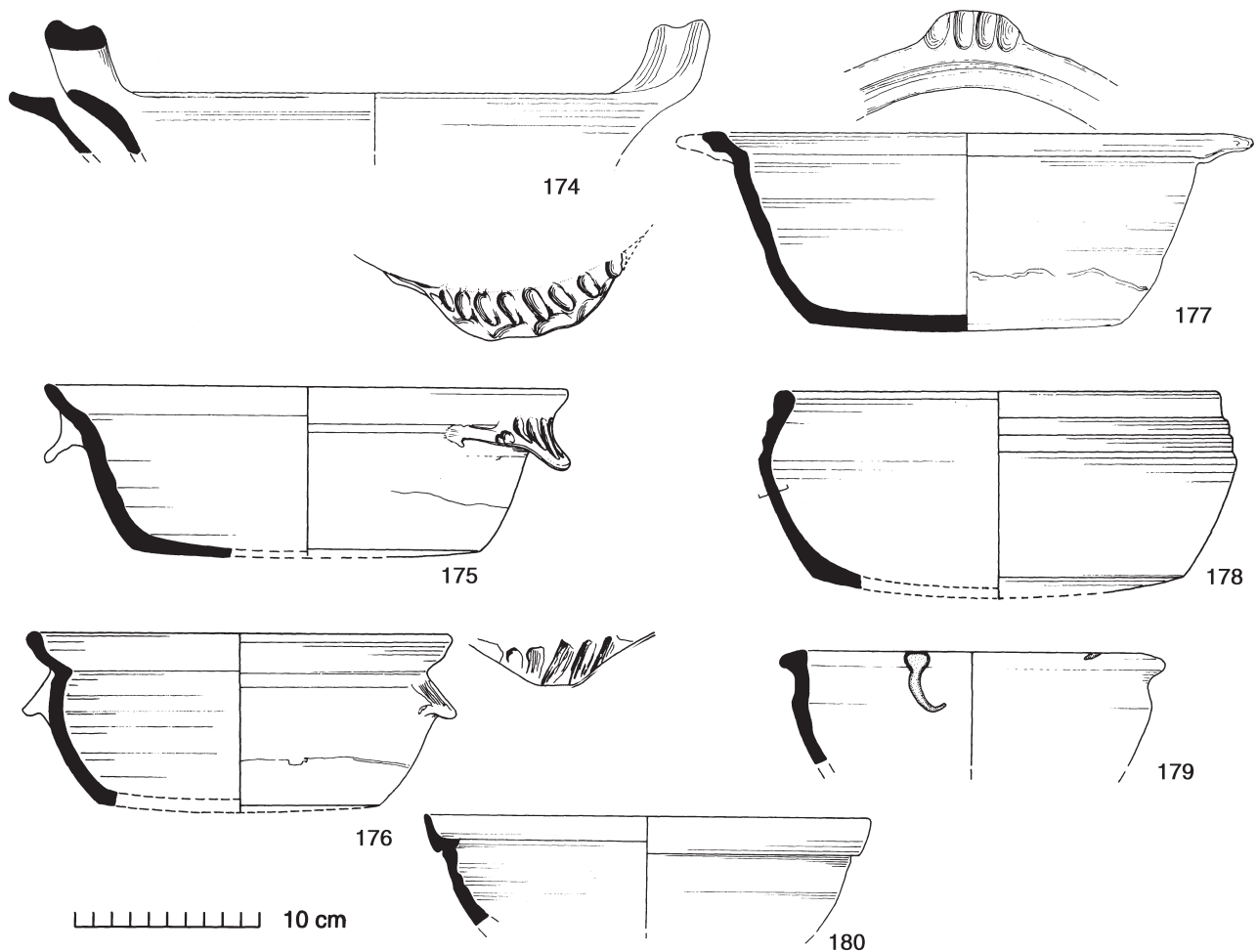

Fig 98 Colchester-type ware: handled bowls (nos 174-177); miscellaneous bowls (nos 178-180; no 180 with internal slip). 1:4.

and perhaps 172. Most of these have a slight bulge below the rim. Although this form was largely contemporary with the broadly flanged bowls, it appears to be much commoner in the first half of the 16th century, sometimes associated with Frechen stoneware and post-medieval red earthenware (Fabric 40). Further distinguishing characteristics are the almost total internal covering of thin, pitted clear glaze and the relatively dull, underfired transitional fabric. It is difficult to imagine a single potter's workshop producing two such different types of bowl at the same time, and these differences could be evidence of more than one production centre in or near the town.

Bowls with thumb lug or ledge handles (Fig 98.175-177) all appear to date from the late 15th/early 16th century and are glazed internally. The carinated bowl Figure 98.178 may be a 16th-century attempt to copy Dutch bowls of similar form. Figure 97.173 is an unusually rounded thick-walled form found in the same pit as a fine Cologne stoneware tankard of about the mid 16th century (see Fig 193.2). The inside of this bowl is caked with a thick white powdery substance, which is almost certainly whitewash.

#### Cups and drinking vessels (Fig 99.181-195)

This category conveniently encompasses a variety of forms whose shape, size and various other attributes are generally associated with drinking vessels. The majority of these are variations of a basic 'thistle'-shaped form with a globular body, and flaring or upright plain rims with either a pedestal or a flattened pad base. These recall cup forms in both 'Tudor Green' ware and Cistercian ware and were probably inspired by these traditions, particularly the latter.

A cup- or shallow bowl-shaped item (Fig 99.182) came from the town wall context of c 1382-1421 (Stratified Group 9) and is the earliest probable drinking vessel in this fabric. It is covered all over with white slip to a level just below the handle, and the inside and the upper handle are covered with green copper-flecked glaze. Originally it might have had a pedestal base. Probably of similar date and form, Figure 99.181 is slipped all over and covered with a dark mottled green glaze. There are rows of stabbed decoration at the upper and lower limits of the globular body and, unusually, a central row of circular grid-iron stamps (see also Fig 102.202).

Goblet or chalice-shaped cups with pedestal bases (Fig 99.183-187, 192) occur in late 15th- and early 16th-century contexts. It is possible, on stylistic grounds, that some all over slipped vessels such as Figure 99.183 and 187 which are green glazed inside and partially outside might date from earlier in the 15th century, but both examples were residual in their contexts. Against this argument, however, a similar all over slipped, semi-sgraffito pedestal cup (Fig 99.192) is known from a context of c 1525-50 (Stratified Group 15).

The fluted base of Figure 99.183 was apparently made by indenting the hollow pedestal. Scored sgraffito lines, possibly caused by the side of a thumbnail and perhaps unintentional, run the length of the flutes. Fluting on the pedestal base of similar cups (Fig 99.185-186) is more faceted than fluted and possibly knife-cut. Similar cups (in Fabric 40) with fluted/faceted pedestals occur in late 15th-century contexts at Chelmsford (Cunningham 1985, 71, fig 9.59-60). Figure 99.185-186 have a much finer, paler fabric covered in a clear glaze similar to the transitional fabrics mentioned below.

Single and multi-handled cups with flat bases and tulip- or funnel-shaped necks are found in late 15th- to mid 16th-century contexts, often associated with Raeren stoneware (Fig 99.188-191, 193-194). They are plain, with a clear or reduced greenish glaze covering most of the vessel but rarely reaching the base. Glaze application is sometimes patchy; the surface sometimes pitted and preserving tiny pellets of raw lead. These forms occur both in the late Colchester-type fabric and also in a finer, more micaceous transitional fabric which is not dissimilar to late medieval Dutch red earthenware, and at its finest bearing a superficial resemblance to medieval Hedingham ware (Fabric 22). The finer fabric is partly a response to the need for thinner-walled vessels. Drinking vessels in the late transitional fabric (Fig 99.188-191, 193-195) share a number of features with other vessel forms in this fabric, particularly 'metal copy' baluster jugs and conical or cylindrical jugs (see above, pp 118 & 122). These include a generally 'metallic' look with sharp angle changes, handles of sub-lozenge section thumbed at the lower junction, and sometimes neck/shoulder cordons and body cordons or raised ribs (Fig 99.190, 195). Knife-faceted bases occur on some three-handled 'tyg' forms as Figure 99.193, recalling similar knife-faceted bases on conical or cylindrical jugs (eg Fig 79.46). The earlier pedestal bases are replaced by flat or pad bases of post-medieval character. Other post-medieval characteristics (presaging those in Fabric 40) are the multi-handled 'tyg' forms (Fig 99.193-194) and the conical beaker or tankard-like form of Figure 99.195 with its all over blistered clear glaze.

The dating emphasis of these transitional flat-based drinking vessels seems to lie in the early to mid 16th century. Figure 99.191 is from a context of c 1475-1525 (Stratified Group 12). Another tulip-necked cup occurs in a context of c 1500-25 (Stratified Group 13, Fig 226.12). The c 1530 date associated with the conical jug (Fig 79.46, see above pp 128-9) can probably be extended to related multi-handled forms as Figure 99.193-194; an almost identical form to Figure 99.193 is known from a mid 16th-century deposit at Braintree (Huggins 1986, fig 6.17).

#### Miscellaneous forms

The following minor forms collectively comprise 11.5% of all Colchester-type vessel forms.

#### Chafing dishes (Figs 100-101 & 102.196-207)

These comprise around 1.5% of all vessel forms. Chafing dishes are thought to have functioned much as modern plate-warmers for keeping hot small portions of food by resting the dish on the three upright prongs above burning charcoal or hot embers placed in the bowl below. None of the Colchester dishes, however, displays obvious signs of scorching.

The earliest chafing dishes in Britain are a few examples in London-type ware from early 13th-century contexts in the City of London (Pearce *et al* 1985, 44-5). A chafing dish from St Aldates, Oxford, comes from a context dated to c 1250-65 (McCarthy & Brooks 1988, 280). A heraldic chafing dish from North Elmham, Norfolk bears the stylised arms of bishop Despenser and is believed therefore to date to the late 14th or early 15th century (*ibid*, fig 60.9).

Colchester-type ware chafing dishes were probably being produced by the second half of the 14th century. The earliest stratified example (Fig 102.199) comes from the town wall context of c 1382-1421 (Stratified Group 9). This is from the bowl of a chafing dish, apparently with an inserted floor, with around four wide rectangular slots cut through the hollow pedestal. The sherd is covered both internally and externally with white slip under a clear glaze. An identical fragment from the Middleborough site has four rounded arch-shaped slots rather than rectangular ones (MID CF128, not illustrated). These last two items may have had the same form as a sgraffito chafing dish from the River Can at Chelmsford, with a hollow, open pedestal pierced by four arches, a shallow curved bowl with a horizontal flanged rim, and a single handle dropping from bowl wall to foot-ring (Cunningham 1985, fig 10.71).

Five Colchester-type chafing dishes with anthropomorphic bearded-mask handles have been recognised. The four examples from Colchester, including Figure 102.197 (the only one from the 1971-85 excavations), are all unstratified. However, the fifth example, from George Street in Harwich, is from cleaning over a soil layer that produced a range of 13th- to early 14th-century pottery including sherds of a Saintonge polychrome jug and Mill Green ware, the latter dating to c 1270-1350 (Walker 1990a, 74, fig 13.14). This could indicate, perhaps, an early to mid 14th-century starting date for Colchester-type chafing dishes, but unfortunately the cleaning layer in question also contained some late medieval and post-medieval contamination and cannot therefore be regarded as completely trustworthy.

The Harwich chafing dish has a fork-bearded mask very similar to Figure 102.196-197 and is associated with a short open pedestal base without slots. Evidence for slots through the bowl has not survived, and none of the anthropomorphic chafing dishes retains its rim. Unlike the Colchester finds, the Harwich chafing dish is clear glazed and lacks slip.

Of the four anthropomorphic dishes from Colchester, one is from Lion Walk (Fig 102.197), two are from unknown locations in Long Wyre Street (Fig 102.196, and Fig 101, left), and one has been published from the grounds of Colchester Castle (Fig 101, right; Cunningham 1982a, fig 28.39). Of these, only Figure 102.196 retains a

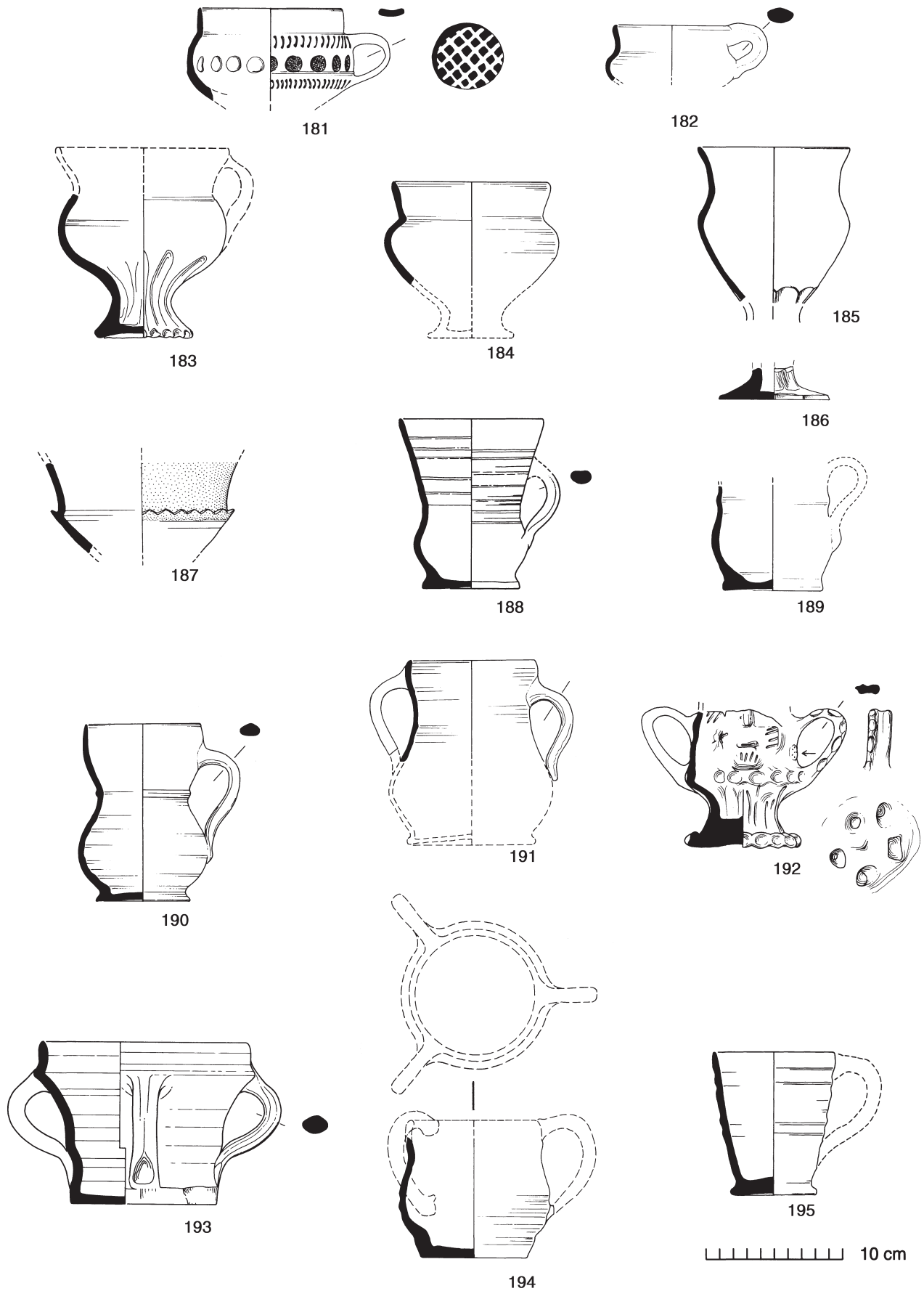

Fig 99 Colchester-type ware: cups and drinking vessels (nos 181-195; (no 192: anthropomorphic cup with all over white slip, sgraffito details and applied stabbed pad near handle)). 1:4; stamp details 1:1.



Fig 100 Colchester-type ware: chafing dish (no 196) with anthropomorphic handles; scars of vertical slots through bowl and through hollow pedestal base; c 1350-1425; surviving height 116 mm.

substantial part of the bowl and pedestal base, all the rest being detached masks from the angle of the bowl. All the masks are covered with white slip through which facial details have been incised sgraffito-fashion, and all are covered with a clear glaze with copper-green flecks except the smaller Long Wyre Street mask which is clear-glazed only. The castle mask fragment differs in having a squared beard and something like a ?projecting head-dress above, which implies a more free-standing attachment than the others. This may be illusory, however, as the mask is flanked by vestiges of knife-cut slots suggesting it was attached as Figure 102.196 and is unlikely to have had the free-standing Saintonge-like form reconstructed by Cunningham

(*ibid*). The other Colchester masks, like the Harwich mask, have forked beards.

The most complete example of this class, Figure 102.196, consists of the lower part of a straight-walled dish with a low carination and a marked bulge or cordon where it joins the hollow flaring pedestal base. The sides of the dish are pierced with a grille of around ten narrow rectangular slots and the pedestal is pierced by three narrow slots at different heights. The floor of the dish is probably applied and two anthropomorphic handles have been attached to the outer carination. White slip appears to cover the outer surface and handles of the dish above the carination but does not extend to the inside, and below the carination there are irregular splashes of slip. Although much decayed, the area above the carination appears to be covered with a clear copper-flecked glaze. A similar pedestal base from the Angel Yard site (40.86 F92) also comes from a white slipped dish with a pedestal cordon as Figure 102.196, although without slots and with a splayed knife-faceted base as Figure 102.206 (Stratified Group 10, c 1400-50).

Very similar bearded masks occur on jugs and possibly chafing dishes in Grimston ware (Norfolk) produced mainly in the 14th century (Clarke & Carter 1977, fig 91.5). These would appear to be the obvious source of inspiration behind the Colchester masks, but it is curious that no Grimston ware has been found here and that Grimston-style face jugs were not imitated in Colchester-type ware. A sgraffito bearded face jug from phase II contexts at Writtle (c 1306-1425), possibly a Cambridgeshire or Mill Green product, provides another good parallel for the Colchester masks and one that is geographically as well as stylistically closer (Rahtz 1969, fig 54.48). Chafing dishes with anthropomorphic handles sometimes occur in Late Medieval Transitional Ware (LMT) at Norwich (Jennings 1981, fig 28.478-9), but these seem to be a little later than the Colchester forms. A better parallel perhaps is with a late medieval sgraffito lavabo from Cambridge with upright lugs decorated with incised grotesque faces (see above pp 141-2). Late medieval chafing dishes (and lavabos) with



Fig 101 Colchester-type ware: anthropomorphic handles from two chafing dishes; sgraffito details, c 1350-1425 (left, CM unaccessioned Long Wyre Street; right, 1953 Castle Park excavations, Cunningham 1982a).

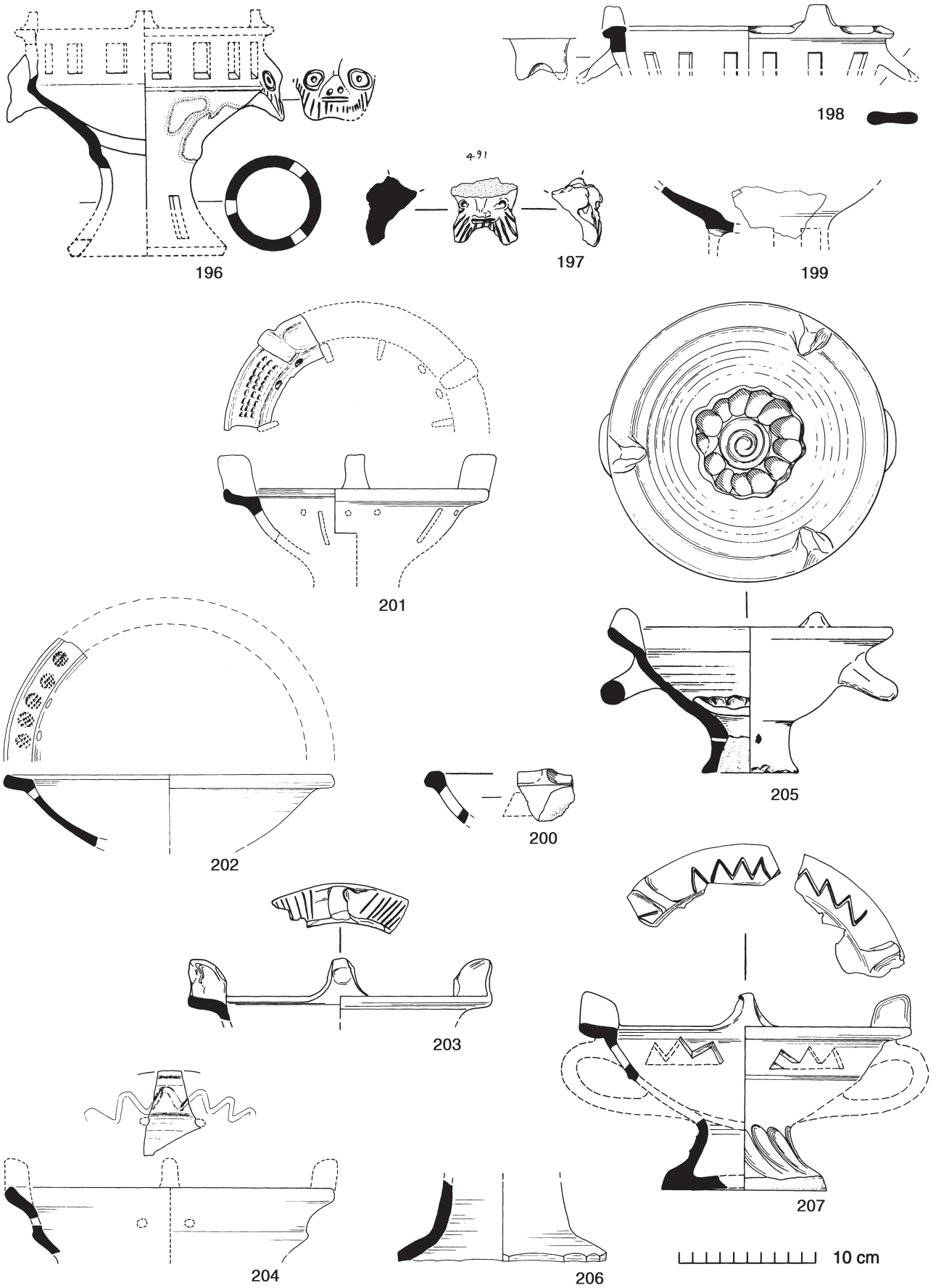

Fig 102 Colchester-type ware: chafing dishes (nos 196-207). 1:4.

anthropomorphic and zoomorphic handles are known from Flanders (Gaimster & Verhaeghe 1992, fig 6). These were probably copied from metal forms, and it could be that the Norwich and Colchester chafing dishes might also have been copied from imported metal forms, particularly in view of the strong trade links which existed between these towns and the Low Countries.

Two early chafing-dish rims (Fig 102.198 & 200) are of simple thickened flat-topped form with long knife-cut facets along the external face of the rim. Figure 102.198 is covered all over with white slip with an internal green glaze, and Figure 102.200 has a partial external slip with a mainly internal green glaze. There are rectangular slots through the wall of Figure 102.198 and a square-section upright prong, probably knife-faceted. The curious lug handle of the latter with its forked terminal appears to be a blank or vestigial fork-bearded anthropomorphic mask, perhaps recalling the decoration of slightly earlier chafing dishes. Figure 102.200, from a 15th-century context, may have had triangular or rhomboid slots.

Chafing dishes are commoner in 15th-century contexts (see Stratified Group 10, Fig 224.44-46, c 1400-50), still often with white slip but increasingly with either a clear glaze or little or no glaze at all. Pedestal bases are commonly knife-faceted (as Figure 102.206) and sometimes perforated with a small hole (as Fig 102.205), but no longer (or rarely) pierced with slots. Sgraffito-decorated chafing dishes were also produced at around this time (see below).

The remaining illustrations (Fig 102.201-205, 207) are of unslipped, clear glazed chafing dishes with broad flanged rims and either open or closed pedestal bases typical of the late 15th and early 16th centuries. These have a variety of pierced slots and perforations. The flange is sometimes decorated with incised, stabbed, and in one case stamped designs (Fig 102.202). Figure 102.207 (Stratified Group 12, c 1475-1525) with its fluted pedestal is probably an imitation of metal forms and has an almost exact parallel from Brintree of mid 16th-century date (Huggins 1986, fig 6.14). Many of these late chafing dishes occur in the more micaceous transitional fabric.

#### Pierced vessels

##### Strainers (Fig 103.208-210):

These are uncommon and all the illustrated examples come from late 15th- or 16th-century contexts. Figure 103.208 is irregularly covered with white slip which is clear glazed internally. It is another example of the late survival on unusual forms of all over slip coverage. Figure 103.209 is of similar date but is plain with a few splashes of glaze. It is probable that Figure 103.210 was intended to be a strainer, but the two surviving attempts at perforation were unsuccessful and it can never have served this function. It is unglazed but with a small accidental slip splash.

##### Lid or fire-cover (Fig 103.211)

This vessel (16th-/17th-century context) has the form of an inverted bowl, but is pierced through the 'base' and has a handle scar near its apex. It is unglazed and very heavily sooted internally. It may have served as a curfew (fire-cover), although it is rather small. Alternatively it could be a lid or perhaps an industrial vessel. An identical vessel, interpreted as a colander or cheese-press, came from the castle excavations (Cunningham 1982a, fig 32.87).

##### Fuming pot (Fig 103.212)

A unique form from a late 15th-/early 16th-century context. This appears to be jar-shaped with vertical slots cut through the walls. The outer surface is covered with white slip and clear glaze covers both sides. Similar vessels in post-medieval Border ware (Fabric 42) have been identified as fuming pots, although their function is uncertain (Pearce 1992, fig 45.430-35).

##### Water sprinklers (Fig 103.213)

Only one definite water sprinkler in this fabric came from the excavations. It is thin-walled and has a relatively fine fabric and a broad bib of clear glaze. In addition to the white slip decoration on the body there may be a slip stripe running centrally down the strap handle. It was associated in a rubbish-pit with a cylindrical jug (Fig 79.46) and a leaden alnage seal of c 1530 (see above pp 128-9). A similar waster fragment from the top of a water sprinkler is known from the castle (Cunningham 1982a, fig 30.51).

##### Costrels or bottles (Fig 103.214-219)

Barrel-shaped costrels are rare in Colchester-type ware, with only three fragmentary examples known: a green-glazed example, probably of the late 13th or 14th century, from earlier excavations at the castle (Cunningham 1982a, fig 28.40); and from more recent excavations, an identical flattened costrel end associated with Mill Green ware (1.81 GF4; not illustrated; diameter 160 mm), and another with clear glaze associated with an early to mid 15th-century assemblage (LWC AF17, not illustrated).

Bottle- or flask-shaped costrels (Fig 103.214), perhaps used as cruets, are more common but still comparatively rare. These are narrow-necked with simple thickened and externally bevelled rims and usually an oval-section handle. The earliest possible example of this form (not illustrated) is a small rod handle once joined to a very narrow-necked vessel and which was found in a context of c 1400 (LWC BF46, see above p 112). Figure 103.214 has a bib of reduced brown glaze and comes from a context of c 1525 (Stratified Group 14). Figure 103.215 (from a 17th-century context) is in a transitional overfired fabric, and it is flattened on its surviving side and has pierced lugs for suspension. It is covered with a reduced dark green glaze and may date from around the mid 16th century.

One of the more distinctive Colchester-type ware forms is that of small biconical or sub-biconical bottles (Fig 103.216-219). These are always unglazed, flat-based and with a thickened, internally bevelled rim. Wasters or 'seconds' of at least two separate vessels have been found in the Lion Walk area of town (Sites A & B), including Figure 103.218 which is intensely overfired and warped. This waster and a second base of this form come from a coin-dated context of c 1400 (LWC BF46; see above p 112). Of similar date, Figure 103.217 (Period 4.1) is from the same cess-pit as a virtually whole Saintonge *pégau* of c 1400-25 (Fig 174.7) and the early pipkin described above (Fig 92.133). The earliest bottles of this kind may well date from the second half of the 14th century. Except perhaps for Figure 103.219, they are not well-represented, and they are probably residual in the many late 15th- and early 16th-century groups. Around two dozen examples have been noted in the excavated material, making this the commonest bottle-like form in this fabric (1.7% of all vessel forms). Their function is unknown but an example in the Colchester Museum (CM 82.1973) has a small spigot-hole near the base (as



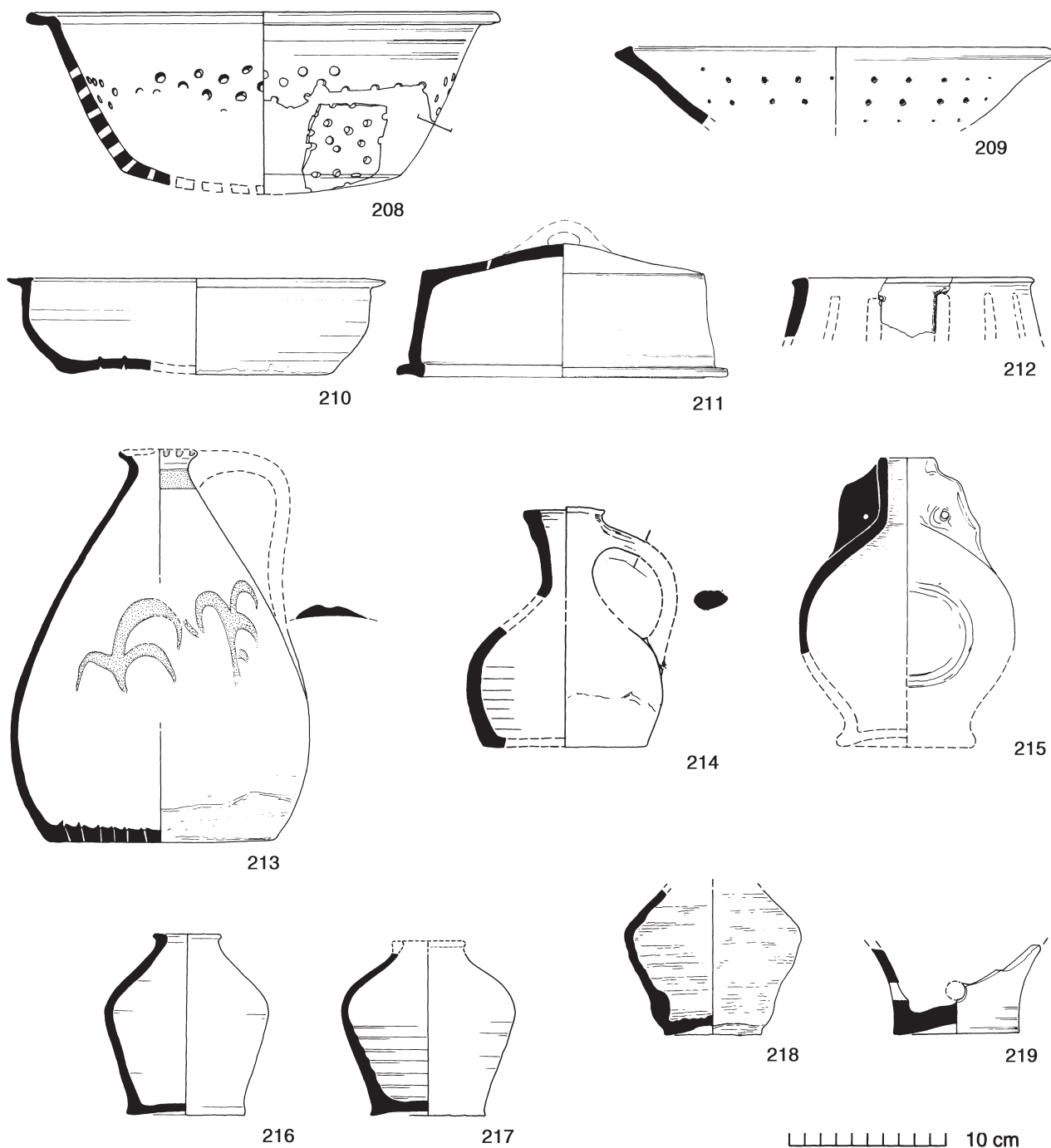

Fig 103 Colchester-type ware: strainers (nos 208-210); ?curfew (no 211); firepot or fuming pot (no 212); water-sprinkler (no 213); bottles or costrels (nos 214-215); biconical bottles (nos 216-219; no 218 is a waster). 1:4.

Fig 103.219). This, together with their small, perhaps standardised size, suggests the storage of a valuable liquid commodity such as alcohol, honey, or lamp oil, etc.

Lids (Fig 104.220-228 and ?229)

These are numerous (5.5% of all vessel forms) and occur from at least Period 3.2 onwards (CPS L48), though most are from 15th- to 16th-century contexts. The diameter range is 110-270 mm with an average of about 160 mm. They

would thus be suitable for covering most medium-sized jars, many of which have purpose-designed lid-seating. Predictably, lids show little chronological development. The form is basically that of an inverted flaring dish or shallow bowl with a simple rim and, most commonly, a flat or slightly splayed, wire-marked top. In the 15th century, some lids have faceted polygonal tops or knobs (Fig 104.225-228). With one exception, all lids are unglazed except for the occasional splash of clear glaze. The only glazed example is a polygonal thumbed knob (Fig 104.227) which is not

certainly from a lid and was clearly intended to plug into the rest of the vessel. It is quite possible that some 'lids' could have served equally well as small dishes. Figure 104.221 contains a thick white deposit or 'kettle scale' internally, presumably caused by evaporating liquids during its use as a bowl. Several others are sooted externally. One unusual lid or possible curfew (Fig 104.229) resembles an inverted wheel-thrown jar base with an added external ridge or 'foot-ring' of thumbled clay. Alternatively it could be the base of an unusual jar.

#### Dripping pans (Figs 104.230-232 & 105.233-235)

These were made to collect dripping juices from meat roasted on spits. At least nineteen examples were recovered. They are all slab-built with heavy external knife-trimming and flat or convex bases. Most examples appear to be from crudely rectangular vessels, though one example could be oval. Virtually all dripping pans are clear glazed internally, though the covering is normally confined to the floor area. Figure 104.230 has a unique grid design of thick smeared slip under a clear glaze. A partial internal covering of white slip occurs on a few items, and on Figure 105.233 there is some sort of slip-painted design, possibly a crudely painted leaf with a crude swag design dropping from the slip-painted rim. Rims are mainly plain or thickened with flat tops. One corner sherd (Fig 105.234) has a horizontal flanged rim on one side and a plain rim at right-angles to this, and may come from a semicircular 'Dutch oven', perhaps intended to fit flush against a fireback. Figure 105.235 and the scar of Figure 104.231 show the sort of broad tongue-like handle common on dripping pans. The pinched corners of the latter served as pouring-lips, while other sherds appear to be from dripping pans with a pouring-lip equidistant from the corners (not illustrated). Virtually all examples are heavily sooted on the underside.

The earliest Colchester-type dripping pan (Fig 104.232) occurs in a deposit associated with late 13th- to early 14th-century pottery including Colchester-type polychrome ware (Period 3.2). Figure 105.234-235 are from the town wall context of c 1382-1421 (Stratified Group 9), and several others come from 15th-century contexts.

#### *Aquamaniles*

Although no *aquamaniles* were identified from the excavations covered in this volume, most of the lower part of a zoomorphic *aquamanile* from 45-46 High Street has already been published (Cunningham 1982a, fig 28). This was thrown as a cylinder with details applied later, and the whole was then covered with a thick white slip and green-flecked glaze. A 14th-century date seems likely.

#### Mortar (Fig 105.236)

A single example of this form exists in the Colchester Museum (unaccessioned). This is in a coarse, unglazed, oxidised, somewhat underfired fabric with quartz and occasional flint inclusions up to 4 mm across. The interior is partly blackened or reduced and is worn from use. The underside of the base is badly spalled, probably due to inadequate drying-out of such an unusually thick-walled form. Two opposite solid lug handles are applied to the outside and there is a pulled pouring-lip between them. A date in the late 14th or 15th century is probable.

#### Industrial vessels (Fig 105.237-239)

These are probably more common than the few illustrated vessels. All the recognised examples shown here are from late 15th- or early 16th-century contexts. Figure 105.237 could be from a cucurbit, a gourd-shaped vessel used in distillation which was normally made of glass rather than pottery. A spouted glass dome or alembic would have fitted on to the cucurbit. This would have been placed on a bed of heat-dissipating sand inside an industrial base such as Figure 105.238-239 (Moorhouse 1972, fig 25, fig 28.5,11). The cucurbit is in a hard oxidised late Colchester-type fabric with a clear internal glaze which also covers the rim.

Industrial or distilling bases (Fig 105.238-239) are slightly more common. Four definite examples have been recognised including a jar with an inturned rim discussed above (Fig 92.132, *see* p 141). The other three examples have bifid or lid-seated rims with a cut-out slot designed to accommodate the downward projecting spout of the glass alembic. Figure 105.238 is typically clear-glazed inside. Fragments of glass alembic and a glass urinal were found in the same context (Rachel Tyson, pers comm; Stratified Group 14, c 1525). Figure 105.239 has internal splashes of clear glaze and specks of white slip. A further slotted base from the Angel Yard site is similar in form to Figure 105.239, but wider and with a plain sagging base. The interior is covered with white slip under a green copper-flecked glaze (40.86 F71; not illustrated). Like the others, the latter is unsooted but there are signs of scorching inside the base as well as a white deposit.

Distilling bases, cucurbits and glass (or ceramic) alembics collectively formed a distilling unit commonly used in the late medieval period, either for the production of nitric acid (for the assay of precious metals) or potent alcohols, or simply for alchemical experiments (*ibid*, figs 25 & 32, 86-7).

#### Candlemaker's troughs (Fig 105.240-241)

Two straight-sided forms are tentatively identified as candlemaker's troughs, a form more associated with late medieval Low Countries red earthenwares. Two fairly small examples of c 1400-25 and c 1475-1525 have been illustrated by Hurst *et al* (1986, fig 65.223, pl 22). There is part of a similar trough-like form in the Colchester Museum, found at East Hill (Fig 105.240). This is in unglazed, oxidised, late Colchester-type ware and is from the corner of a unique box- or trough-like object. The walls of the trough are gently flared outwards away from the centre of the vessel and the surviving end has traces of a strap handle that probably rejoined the wall below the now-missing rim. The corners are projecting and lightly thumbled along the surviving length. There are no obvious signs of use.

The second possible example is from the Lion Walk excavations (Fig 105.241, unstratified). This is from a flaring-walled form with a broad straight-edged flanged rim. The upper surface of the flange is covered with white slip under a clear glaze. Below the rim externally is a pinched-out horizontal band rather than an applied thumbled strip, and there are traces of sooting on the interior. It is difficult to imagine what other sort of vessel form this rim could represent unless it is from an unusual type of dripping pan, curfew or louver. Even in its fragmentary state the East Hill trough is clearly larger than the examples illustrated by Hurst *et al* (*ibid*), and it does not possess or retain evidence for the side supports that were normal on candlemaker's troughs. Nor does the other fragment (Fig 105.241) exhibit

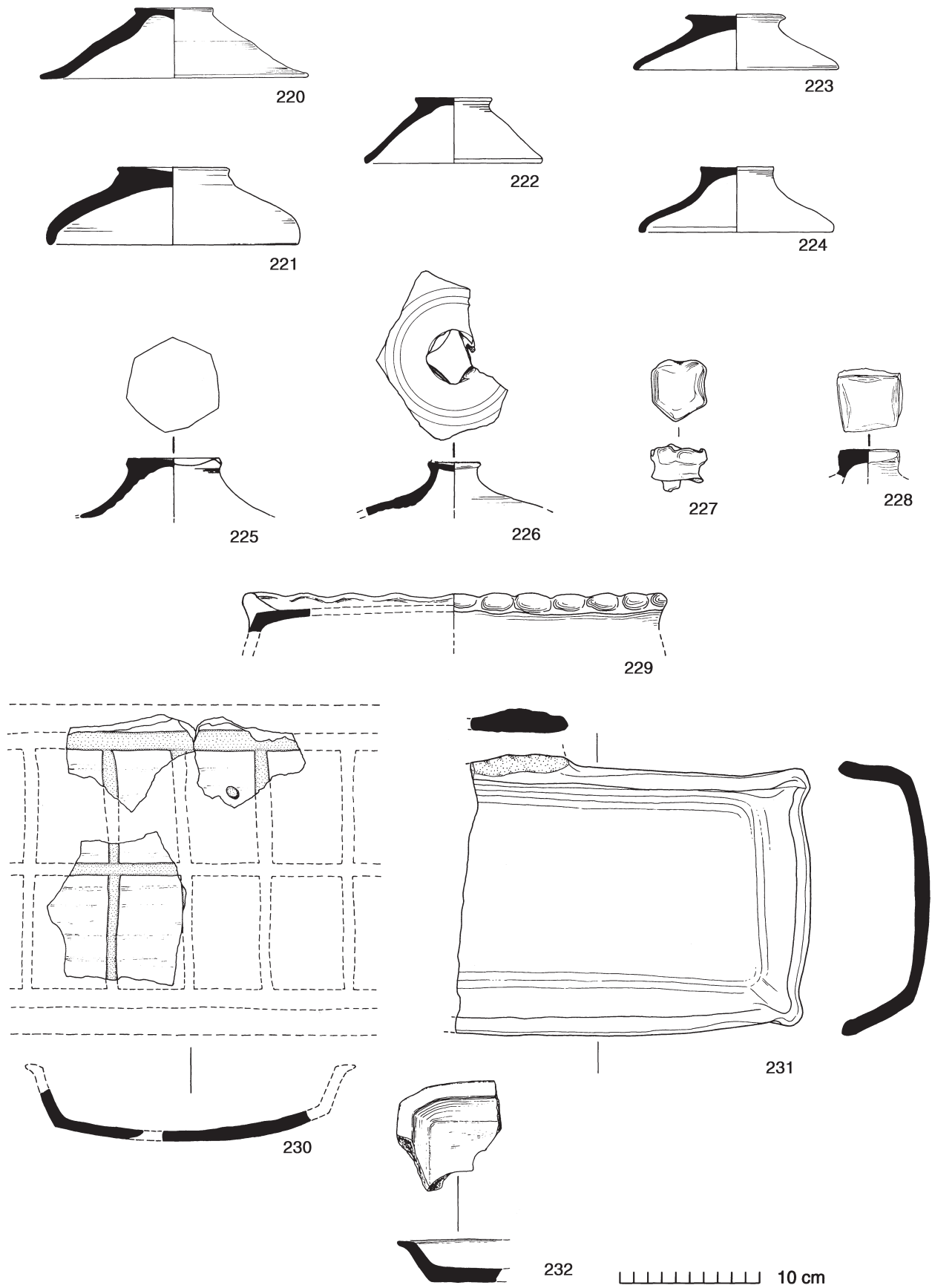

Fig 104 Colchester-type ware: lids (nos 220-229); dripping pans (nos 230-232). 1:4.

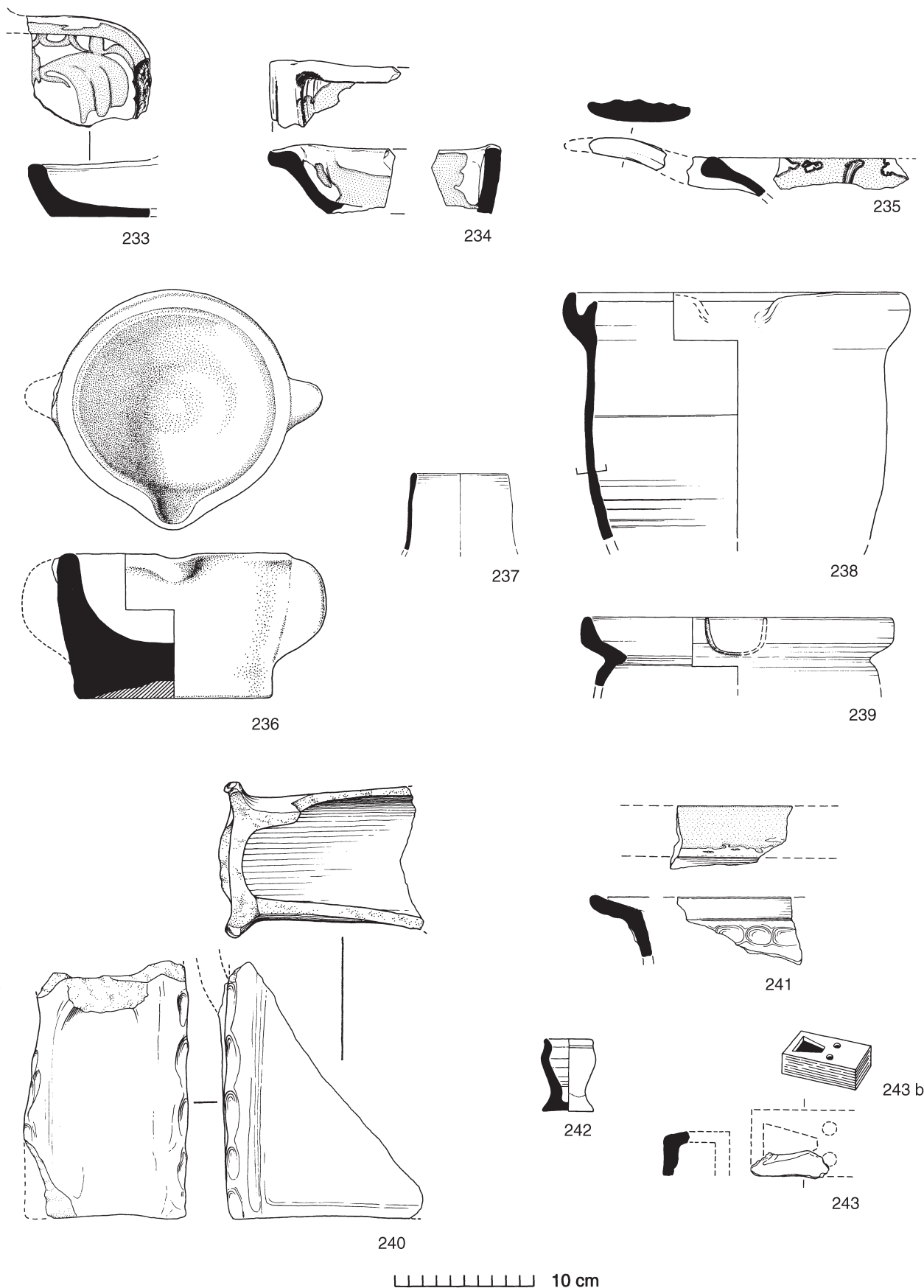

Fig 105 Colchester-type ware: miscellaneous forms — dripping pans (nos 223-225); mortar (no 236); industrial vessels (nos 237-239); ?candlemaker's troughs (nos 240-241); ?inkwells (nos 242-243). 1:4.

the usual crenellations on the rim on which the candles would have been rested after being dipped in hot wax. It is possible of course that these features have just not been recovered. The large size is not a problem, however, as some candlemaker's troughs were up to 90 cm long (*ibid*, 140). A very large example in the Museum of Folklore, Ghent has a thick flanged rim with an external thumbled strip below, similar to Figure 105.241, and also side handles as Figure 105.240. The 'middle style' slip decoration on the rim of the former suggests an earlier 15th-century date, but a general 15th- to early 16th-century dating is likely for both. A similar trough-shaped vessel (in late Tyler Hill ware) is illustrated from the Hospital of St Mary at Ospringe, Kent, which was dissolved in 1516 (Thorn 1979, fig 44.107).

#### Inkwells or miscellaneous unidentified forms (Fig 105.242-243)

A small pedestal-footed pot in Colchester Museum is tentatively interpreted as either an inkwell or possibly a candleholder. It is in a pinkish late and transitional Colchester-type fabric with a greenish-yellow glaze covering the upper two-thirds and just extending inside the rim. A dark ink-stained or heavily sooted band extends to a depth of 10 mm below the inside of the rim, but not below this. The rim and base are heavily chipped. Although the small size and form of this vessel would have made it suitable for an inkwell, it is difficult to explain why the 'ink' stain should be confined to the upper part of the vessel. Alternatively it may have been a candleholder/stick and the dark band caused by scorching from burning candle stubs. The date is probably 16th century.

The second item (Fig 105.243) is part of a slab-built hollow block-like object, covered externally with white slip and clear glazed on the top. There are vestiges of a circular perforation to one side (?one of a pair) and a roughly triangular cut-out at one end of the object. There is no internal staining or any other signs of use. However, the object may have been an inkwell with a triangular filler hole and two or more quill holes (as reconstructed in Fig 105.243b). Alternatively, it might have been an unusual oil lamp or a flower block. The context is late 15th/early 16th century.

#### Louvers

(Figs 106.244, 107.245, 108.246-249, 251 & Fig 110)

Fragments of at least a dozen louvers (elaborate chimney pots or roof ventilators) were found on the 1971-85 excavations, and subsequent excavations (to 1990) bring this number to at least twenty. Louvers in Colchester-type ware have been the subject of an earlier study by Cunningham (*CAR 3*, 211-14); this remains in many respects a valuable survey, the most important results of which were the identification of Dunning's famous Great Easton louver (Dunning 1966a) and three very similar louvers from Chelmsford as products of the Colchester-type industry.

However, excavations in Colchester at 31-36 East Stockwell Street and Angel Yard have produced two substantially complete louvers which greatly extend our knowledge of the original appearance and variety of this form.

The East Stockwell Street louver (Fig 106.244 & Fig 110) must rank among the finest examples of medieval louvers found in this country. About 60% of the louver survives, mostly from one side. It is somewhat overfired with a coarse, very sandy steel-grey fabric with rare inclusions of

coarse angular flint and brown to dark-brown surfaces. The outer surface is decorated with thick white slip painting beneath a lustrous clear lead glaze, which is decayed in places, and which covers the upper two-thirds of the vessel. Globules of raw lead resulting from the glazing process are embedded in the upper surface of the horizontal flange. Rare green specks in the glaze result from reduced iron oxides in the clay rather than from added copper.

A novel feature of the East Stockwell Street louver is its simple beehive shape. This tapers very gently upwards from a wide base to a slight angle which defines the dome at the level of the uppermost tier of apertures. The body is clearly wheel-turned. It is perforated by three tiers of staggered apertures, six per tier, each surmounted by an applied baffle-plate or canopy. The lower tier is demarcated by an applied horizontal flange with thumbled raised edges. On many Colchester-type louvers the flange forms a continuous feature around the circumference, but on this example it occurs only as a discontinuous ledge between adjacent baffles.

The inspiration behind the overall appearance of the louver was clearly architectural. Like string-courses and ledges, the horizontal flange and lines of horizontal slip painting define the positioning of the window-like apertures. The upper and lower sets of baffles are in the form of pointed Gothic arches with a single cusp at the apex. Each baffle would have terminated in a finial but unfortunately none of these, nor the larger hollow finial from the apex of the dome, has survived. It is likely that the baffle finials would have taken the form of flattened discoid knobs, as on the Angel Yard louver, while the dome finial may have resembled that of the Chelmsford louvers (*CAR 3*, fig 200.5).

Extra definition is given to the face of some of the Gothic arches by a lightly incised border, but this is not always clear beneath the white slip and glaze covering the face of the arches. In a staggered position between the upper and lower Gothic tiers is a tier of smaller round-headed apertures protected by sloping square canopies. At the lower edge some of the canopies carry a series of thumbled indentations. On the sloping square roof is a painted square of cream slip containing either a cross or a horizontal bar on alternate canopies.

Between the base of the louver and the first tier is a painted frieze formed by a pair of opposing zig-zags bounded by horizontal lines. Each alternate lozenge created by this scheme has been painted in. In the gaps between the lower apertures is a large painted square containing a spiralled line resembling a reversed '9'. In the gaps between the upper apertures the painted decoration takes the form of simple Gothic windows with internal tracery.

A rough scheme is evident in the positioning of the various painted elements, with square painting occurring below the square canopies and Gothic painting above the (lower) Gothic baffles. The square space immediately above the lower baffles was deliberately left blank; any decoration here would have been obscured by finials.

There are no traces of sooting inside so it may have served as a ventilator rather than a chimney pot. Nor does the surviving section of base provide any evidence for the way it was attached to the roof. A small excavation in 1989 at another location in East Stockwell Street (Benfield & Garrod 1992) produced fragments of a second louver almost identical in style to the 1987 louver, with cusped Gothic baffles and slip painting which includes a simpler version of the

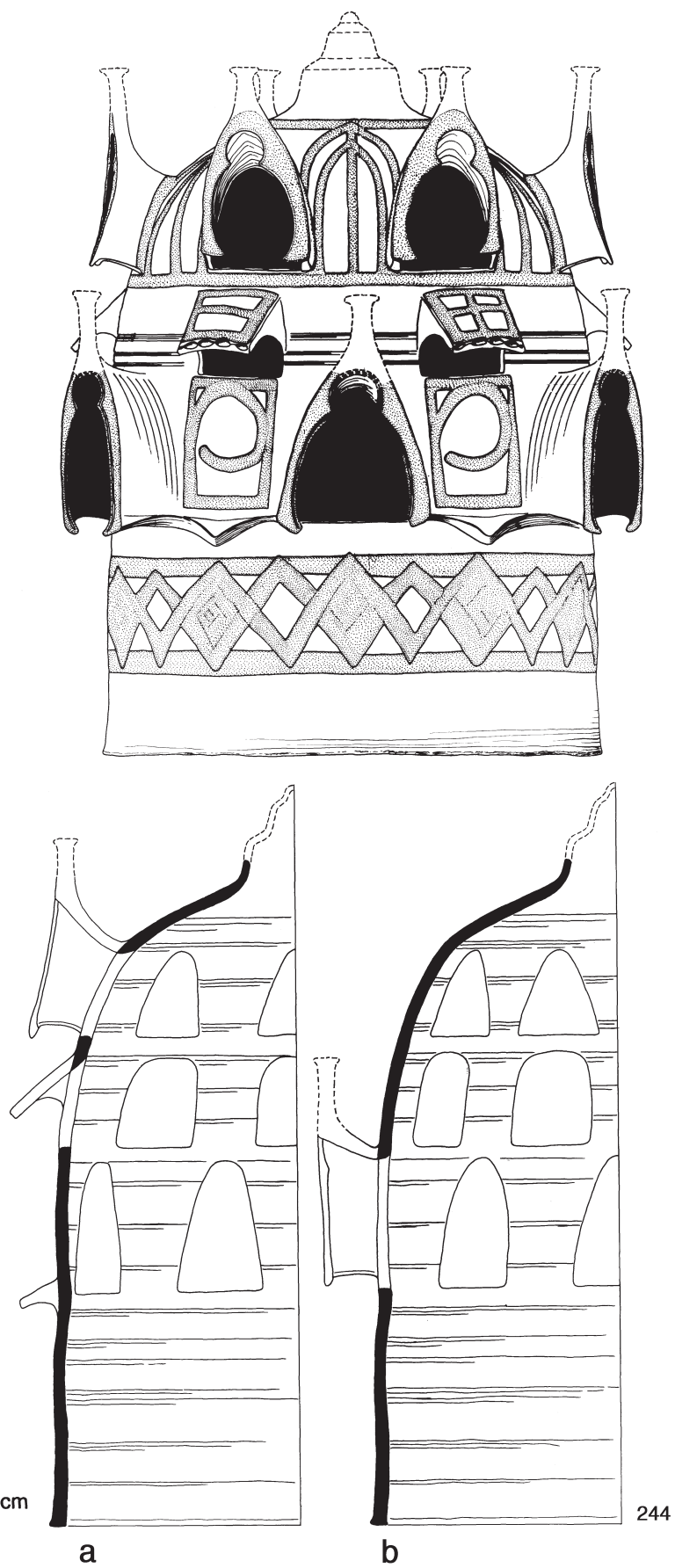

Fig 106 Colchester-type ware: louver, from East Stockwell Street (no 244). 1:6.

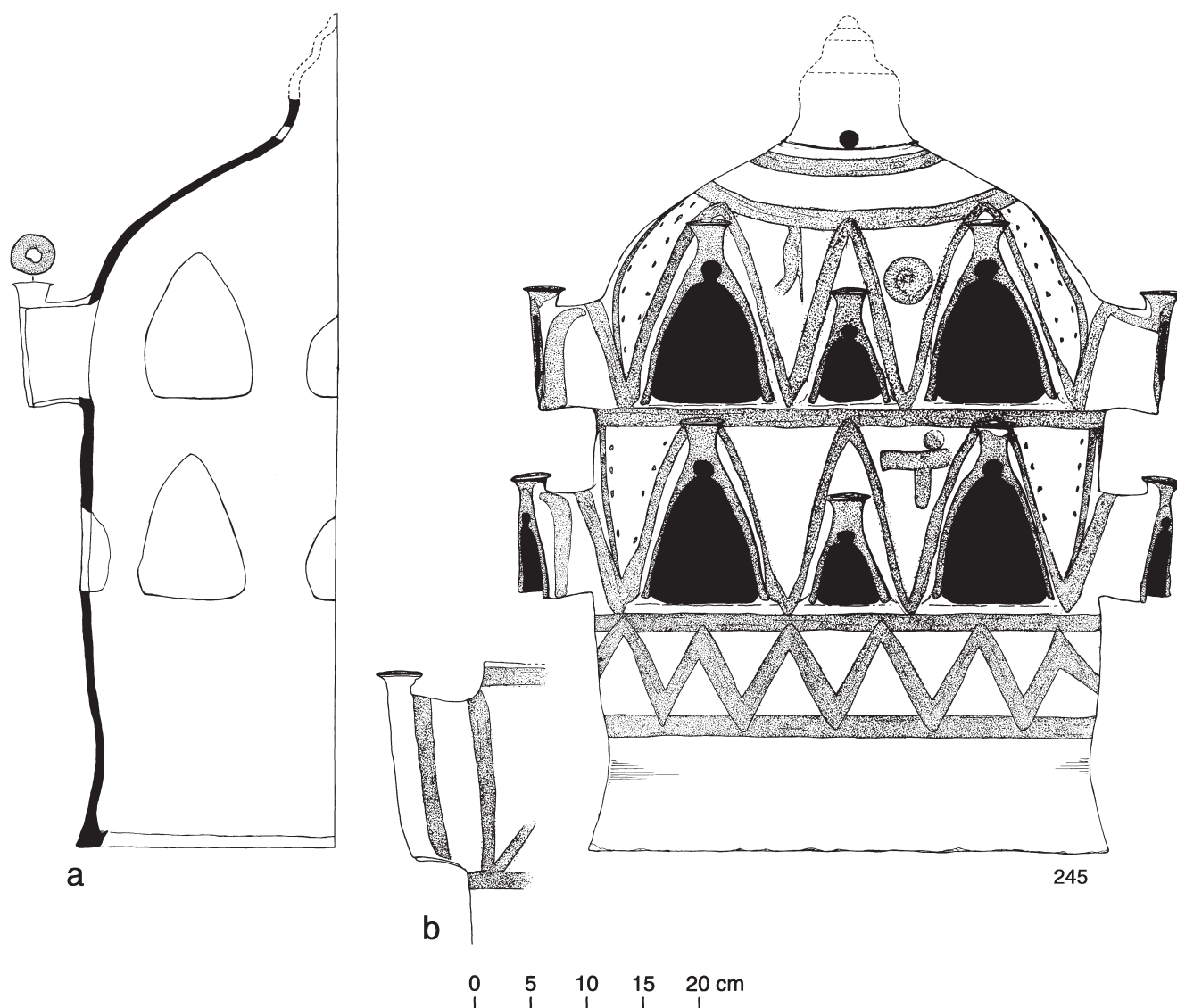

Fig 107 Colchester-type ware: louver, from Angel Yard (no 245). 1:6.

painted Gothic window. A large piece of crested ridge tile with dark brown glaze came from the same layer (but also 17th- and 19th-century pottery).

The Angel Yard louver is not so well preserved as the East Stockwell Street louver. It survives as 74 sherds forming around 35-40% of the whole object. Enough sherds join to reconstruct the profile shown in Figure 107.245, though there are many gaps in the decorative scheme which have been ignored in the illustration for the sake of clarity. The latter (drawn by Barbara Hurman) should therefore be regarded as an idealised reconstruction.

The fabric is oxidised with orange-brown surfaces below the first tier and increasingly browner, darker surfaces above this. There is a broad well-defined grey core similar to many vessels in the late Colchester-type fabric. It is rather less sandy than the above louver with abundant very coarse red clay pellets, moderate coarse white quartz grains and sparse coarse flint. It is decorated, as the above, with thick white slip painting beneath a glossy clear glaze that covers

the entire outer surface (except some of the canopies which are partially covered) down to the level of the lowest horizontal slip line where it ends sharply. This would suggest that the glaze was painted on rather than dusted on in powder form. It is also obvious from the many internal irregularities and the complete lack of turning marks that this vessel was hand-made, which is surprising in view of the obvious turning marks on the East Stockwell Street louver.

Otherwise the Angel Yard louver is very similar in concept and general appearance to the previous louver. It has the same beehive shape as the latter except that the base is more splayed and the inner edge bevelled off. At the apex of the dome is a hollow (broken) finial defined by a deep groove above which is a large perforation of unknown function. Another rougher perforation lower on the dome seems to have been caused by the removal of a large pebble from the fabric (not shown). There are only two tiers of single-cusped Gothic apertures, with each tier composed of eight alternating larger and smaller canopies. At least one of the smaller canopies has a grooved border, as on the East

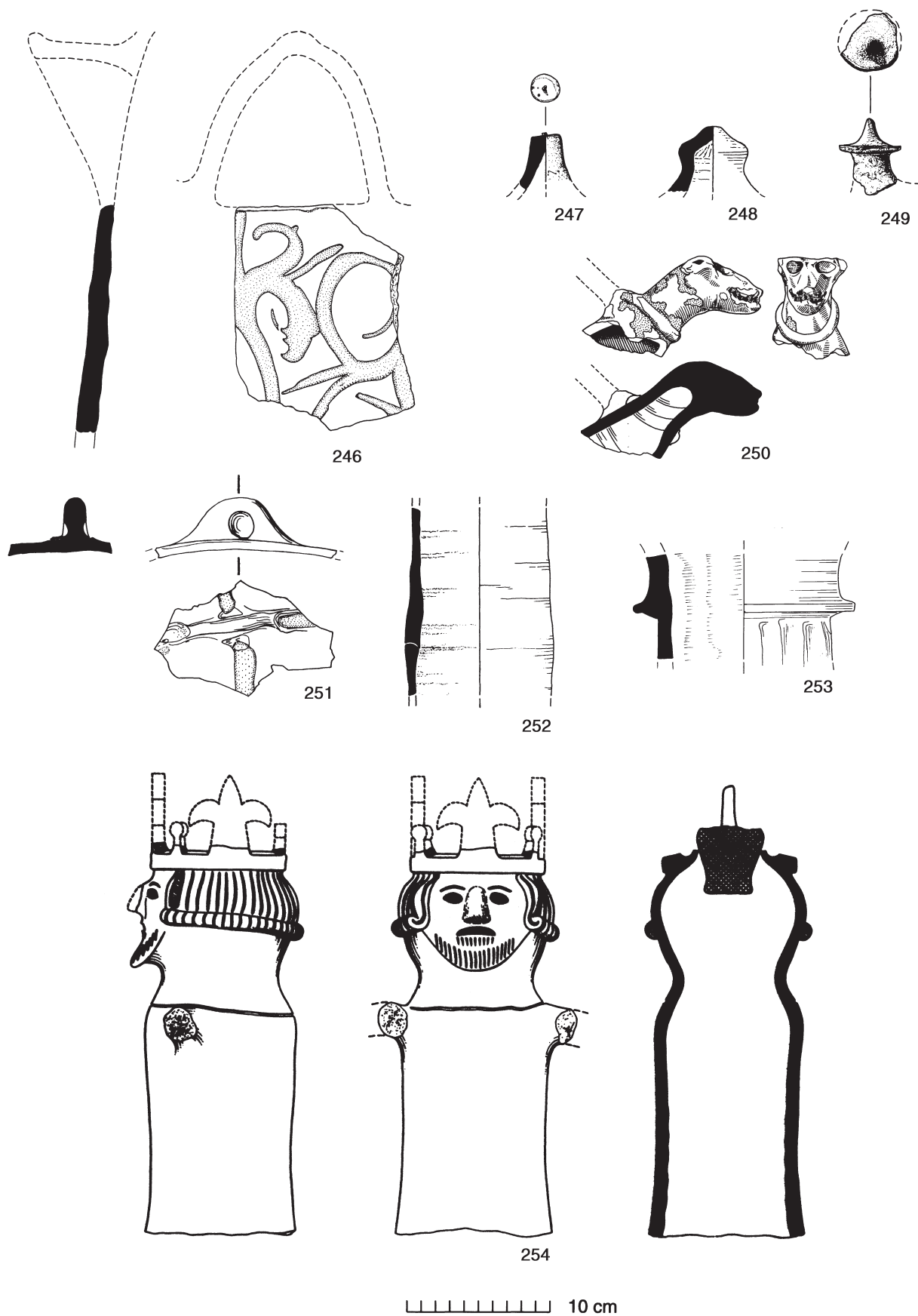

Fig 108 Colchester-type ware: roof furniture — louver fragments (nos 246-249 & 251); finials (nos 250, 252-254). 1:4.



Stockwell Street louver, but in general the canopies are more straight-sided and thinner than on the latter and with insufficient room for incised borders. Each canopy is surmounted by a flattened discoid finial, sometimes with a central dimple, and painted with a ring of white slip. The louver is complete enough to show it was made without the usual applied horizontal flange. Like the previous example, there is a painted frieze of white slip below the first tier which is formed by a simple zig-zag between two horizontal lines. The tiers of apertures are defined by further horizontal white lines, although the two horizontal lines on the dome appear slightly eccentric in execution and not truly horizontal. Slip also covers the flattened faces of the canopies and continues upwards (though not in every case) to merge with the slip painting on the finial. Each of the Gothic canopies is outlined by a slip-painted arch or zig-zag on the wall of the louver which is linked to the main horizontal lines. Secondary slip-painted lines (only visible obliquely) are looped over the canopy proper, and there is sometimes a third loop further along the canopy either set back from the canopy face or merging with the slip painting on the latter. There is a fair amount of variation in the decoration of canopy sides or baffles, particularly on the smaller ones. The gaps or spandrels between the arches are, in most cases, filled with simple slip designs, rows of dots or pellets, circles and a variety of more obscure motifs. The slip itself is of varying thickness, quite thick in places or appearing thin, oily and smeared in others. It was probably applied with the fingertip. No evidence survives for internal sooting or the method of attachment.

#### Louvers: discussion

In most cases where it is possible to determine the method of manufacture, the body of Colchester-type louvers has been wheel-turned, the Angel Yard louver being a notable exception. Vessels of this size would hardly have been thrown on the wheel; rather the body would have been built up in sections on a turntable or slowly-revolving wheel. One of the functions of applied horizontal flanges and cordons may have been to disguise and strengthen the junctions between luted sections of the body.

All louvers in Colchester-type ware appear to be of Dunning's type 1, a separate structure designed to fit over a hole in the roof (Dunning 1966a, 78) or perhaps to sit on a chimney stack. Louvers of type 2, which incorporate a ridge-tile, are unknown in Colchester-type ware. Bases are mostly plain or with a slight internal bevel (eg Great Easton, Angel Yard), with little evidence as to their method of attachment to the roof. The base of one of the Chelmsford louvers (*CAR 3*, fig 200.5) has a large solitary perforation which may have allowed it to be secured to the roof by a wooden peg. The Great Easton louver (Dunning 1966a, figs 26-7) has a down-turned horizontal flange below which the base was tapered, thus allowing it to be slotted into a hole in the roof. A similarly flanged object from Colchester (Fig 108.253), lacking slip or glaze, might also come from a louver although it is much smaller than any other example and could possibly come from a roof finial or even, although less likely, a water-pipe.

In the light of recent discoveries it can now be seen that Colchester-type louvers occurred in at least three basic shapes: beehive-shape, barrel-shape and 'light-bulb'-shape (Fig 120, bottom). Variations in the outward appearance of these types are provided by the addition of baffles or canopies and finials together with different schemes of slip decoration and glaze colour. Beehive-shaped louvers are

exemplified by those from East Stockwell Street and Angel Yard. Not enough of the second (1989) East Stockwell Street louver survives to determine its shape. Fragments from one other example of a beehive-shaped louver can now be identified from the Middleborough site, and this shows the same slip-painted '9' motif as the East Stockwell Street louver (*CAR 3*, fig 200.1-2). Judging from its curvature, a louver fragment from Culver Street might be another example of this type (Fig 108.246).

Barrel-shaped louvers are known only from Great Easton which, as the name describes, is roughly barrel-shaped with a straight tapering base. The third type of louver has a bulbous upper part and a tapering lower part which ends in a gently splayed base. These 'light-bulb'-shaped louvers are exemplified by the three examples from Chelmsford (*CAR 3*, fig 200.5).

A notable feature of louvers in Colchester-type ware is their large size. The record is still held by the Great Easton louver which survives to its full height of around 700 mm, making it the tallest example of its type in the country (Dunning 1966a, 78). This is followed by the Angel Yard louver surviving to a height of around 666 mm at its broken finial which, when complete, must have exceeded the Great Easton louver. The East Stockwell Street louver survives to a height of 595 mm while the smaller Chelmsford louver had an estimated height of around 488 mm.

Other features common to Colchester-type louvers include triangular (or Gothic) baffles and square canopies, often on the same vessel. Finials of various types are also very characteristic as are horizontal flanges and cordons which are often frilled. Not every louver will necessarily display all of these features. Triangular baffles, square canopies and frilled cordons occur on all three types of louver body, but the beehive-shaped Angel Yard louver lacks both square canopies and cordons. Cusped Gothic baffles have so far only been noted on beehive-shaped louvers. All louvers that are complete enough show evidence of finials of some sort at the apex of triangular baffles and at the apex of the louver dome.

Wheel-thrown hollow finials attached to the baffles have so far been noted only on barrel-shaped (Great Easton) and 'light-bulb'-shaped (Chelmsford) louvers, but not on beehive-shaped louvers (East Stockwell Street, Angel Yard). Despite their attribution to the Colchester-type industry, there is as yet little evidence from the town for louvers with hollow finials such as those at Great Easton and Chelmsford. There is one piece of a hollow biconical finial from Culver Street (Fig 108.248) with a partial white slip and splashes of clear glaze. This is quite similar in size and appearance to the Great Easton finials, though it is rather thicker-walled and could possibly come from the apex of a louver dome. It may just be a matter of time before unequivocal evidence for this type of louver turns up in Colchester.

Other types of finial found on triangular baffles include simple nib finials (see Fabric 20, Fig 66.66 & *CAR 3*, fig 200.4), and flattened discoid knobs which are found in exaggerated form on the Angel Yard louver (and perhaps once on the East Stockwell Street louver). Closely related to this are what might be termed 'sombbrero'- or 'toadstool'-shaped finials (Fig 108.249, white-slipped), and lastly there are hollow truncated conical finials (Fig 108.247, white slipped). Further information on finials is provided by fragments from a louver in medieval greyware (Fabric 20, Fig 66.65-66), which demonstrates that nib and 'sombbrero'

finials may occur on the same louver and that truncated conical finials may accompany these as a secondary finial set further back on the ridge of the same baffle.

Cunningham, in her 1984 study (*CAR* 3, 211-14), discussed the evidence for Colchester-type and other louver fabrics in Essex. Louvers in Colchester-type ware are known from Great Easton, Chelmsford, Heybridge (near Maldon), West Bergholt (near Colchester), and Colchester itself (*ibid*, fig 201 for distribution map). Cunningham has also suggested, though tentatively, that a louver from the Manor of the More, Rickmansworth (Hertfordshire) might also be a Colchester product although it would require scientific analysis to be certain of this. There is, however, no parallel at Colchester for the horned finial projections shown on the latter (Dunning 1966a, fig 28).

Many English louvers have an architectural character provided by apertures and canopies which evoke medieval church fenestration. Finials, likewise, sometimes crown prominent points of louvers as they do buildings. Rarely is this architectural connection so clearly stated as on the East Stockwell Street and Angel Yard louvers with their neatly made cusped Gothic arches, simulated moulding (incised borders), and elegant finials. Close parallels are few but include a very similar fragment of a louver baffle-plate from Battle Abbey, Sussex which also has a Gothic arch with internal cusps and incised borders (Streeten 1985, fig 24.15), and also a fragment from Weybread, Suffolk which has an arcade of Gothic arches, where each arch is surmounted by a cross in high relief and the spandrels between the arches are decorated (Dunning 1966b, pl 46a-b).

Square or rectangular openings with canopies, a recurring feature of Colchester-type louvers, are known from other locations in southern England, as at Southampton (Dunning 1975, fig 216.1419) and on a 'house-shaped' louver from London (Pearce *et al* 1985, fig 81.447). Except for rare peg-holes, circular apertures are a feature that has not so far been noted on Colchester-type louvers and they are generally very rare on louvers from northern Essex. In contrast, circular apertures are a fairly common feature of louvers in London-type ware (*ibid*, fig 83), and it is towards London, in south and south-west Essex, that louvers with circular apertures are found, as at Waltham Abbey (Huggins 1978, fig 18) and Hadleigh Castle (Drewett 1975, fig 23.245-7) both overlooking the Thames estuary. Where these louvers were produced is not known but they are not in Colchester-type ware (*CAR* 3, 213). Only one example of a circular louver aperture is known from Colchester, and significantly this is in London fine ware (Fig 43.6).

#### Louvers: dating and context

Louvers are difficult to date precisely. They may have remained in service on a rooftop for upwards of a century or more before falling to the ground and becoming buried. Dunning (1959b, 178 note 4) attributes louvers of type 1 to the late 13th and 14th centuries. The evidence from Colchester, which is not closely datable for this period, is broadly in agreement with these dates. However, louvers are now known from earlier contexts in London, as at the Seal House waterfront 3 of c 1210, and throughout the Seal House/Trig Lane sequence between c 1240 and 1440 (Pearce *et al* 1985, 47,142). So far only type 1 louvers have been identified in London-type ware.

Fragments, probably from a louver, from Long Wyre Street in Colchester (COC L113, Period 3.2), came from a late

13th- or early 14th-century context as suggested by associated pottery. This included sherds of a Colchester polychrome jug copying Mill Green polychrome ware (see above, p 127). The possible louver (not illustrated) is much thinner-walled than usual and wheel-turned. It comes from the expanded globular area of a vessel which retains the lower corner of a knife-cut aperture and vestiges of some sort of canopy over this. A thickly painted line of white slip outlines the aperture in much the same manner as other slip-painted Colchester-type louvers, and it has a patchy clear glaze. Despite its thinness it is difficult to imagine a more likely identification than that of a louver, which makes it perhaps the earliest datable example from the town.

A fragment from the castle bailey can be attributed to the late 13th to 14th century (Cunningham 1982a, fig 28.41), and fragments of three separate louvers came from other Colchester contexts of Period 4.1 (c 1350/1400-1500). Most louver fragments occurred as residual elements in post-medieval contexts. One of the Middleborough louver fragments (*CAR* 3, fig 200.3), with discoid finial and slip painting, was associated only with 13th- and 14th-century pottery (MID CF115, unphased) but much of this could be residual. Another Middleborough fragment comes from an arched-shaped canopy with white slip on the face of the arch and slip splashed behind this under a clear glaze. This is reminiscent of the slipped faces of Figures 106.244 and 107.245. The Middleborough fragment is from Period 4.1 backyard metalling behind Building 75, but was associated only with late 13th- to 14th-century pottery (MID CL61).

The much rarer greyware (Fabric 20) louvers from the town, like the rest of that fabric, probably disappeared in the late 14th century (see p 92). As fragments from a greyware louver occurred in the same context as a louver fragment in London fine ware, then a late 13th- or early 14th-century date may be likely. This is of some relevance because the three types of finial found on the greyware louver are also found on Colchester-type ware.

Unfortunately the East Stockwell Street louver (Fig 106.244) was not recovered under ideal conditions. It was exposed in a section by a mechanical excavator at the end of a rescue excavation. Several pieces of the louver, along with some plain, probably 16th-century Colchester-type ware, had been used as rubble in the footings of a post-medieval brick wall, probably of the 16th or 17th century. Directly below the brick wall, but separated from it by a number of layers, was a medieval oven constructed of peg-tile sealed by an ashy deposit.

Much of the Angel Yard louver was residual in 17th-century layers (40.86 L20, L24), but one fragment was found in a context (F119) containing 15th- to early 16th-century Colchester-type ware in addition to a coin of 1399-1453. The flanged object (Fig 108.253) occurred only with residual pottery and a small sherd of 13th-/14th-century Colchester-type ware. Figure 108.246, which may be a beehive-shaped louver, came from a late 15th- or early 16th-century pit. The finial (Figure 108.248) came from a similarly-dated context.

Despite the paucity of good dating evidence it is possible to propose a rough outline for the development of Colchester-type louvers. It is apparent that louvers follow the same general trend seen in other Colchester-type products, ie they pass from an early stage of all over external coverage with a white slip under a green-flecked glaze, to a later stage of slip painting beneath a clear glaze. On domestic

vessels this transition occurred towards the end of the 14th century. The slip painting seen on Colchester-type louvers is not, however, the thin dilute application of the latest decorative styles (c 1450-1550), but the thicker semi-plastic application of slip that seems to have been present in a small way from the earliest days of the industry and gradually developing into the later thin slip.

It is suggested that louvers may have first appeared in Colchester in the second half of the 13th century, perhaps c 1275 (Fig 120). This includes louvers in both sandy greyware (Fabric 20) and Colchester-type ware. At this early stage (c 1275-1350), louvers could occur either with an all over or patchy external covering of white slip under a green-flecked glaze (eg Colchester, Chelmsford), or more rarely unglazed save for a few splashes (Great Easton). Green-flecked glaze on an unslipped body and thick slip painting beneath a clear glaze are also present but less common.

The earliest louver shape we know of is the barrel-shaped Great Easton louver dated to c 1300 or soon after (Dunning 1966a, 74). This is already at an advanced stage of the potter's art with its wheel-thrown hollow finials and graceful 'Moorish' appearance. As it is unique to the Great Easton louver, we do not know if the barrel shape was current after this date. We do know, however, that hollow finials of Great Easton type are found on the similar but 'light-bulb'-shaped louvers at Chelmsford, also covered with a cream slip under a green glaze (CAR 3, fig 200.5). The Chelmsford louvers are not closely dated — a fragment of one was built into a garderobe wall, probably in the 14th century (*ibid*, 213) — but because of their similarity to the Great Easton louver they must at least date from some time in the first half of the 14th century.

At Colchester the form of the earliest louvers cannot be reconstructed from the small fragments available. The late 13th- or early 14th-century louver from Long Wyre Street had a globular body and was thickly slip painted. Louvers with simpler finials than those of Great Easton and Chelmsford seem to have been more common at this early date. Simple nib, 'sombbrero' and truncated conical finials seem to have been the rule.

The only reconstructible louvers from the Colchester excavations are of the beehive-shaped type, although the globular body of the smaller, earlier fragment from Long Wyre Street could be of 'light-bulb' shape. It is clear that the East Stockwell Street and Angel Yard louvers must be fairly close in date given their similar appearance. Apart from their beehive shape, the other major innovation of these louvers is their elaborate Gothic apertures with their single cusp, a feature not found on the (presumably earlier) all over-slipped louver forms. Because the East Stockwell Street louver retains the applied horizontal flange and square canopies of the earlier louvers, and because the Angel Yard louver seems to be in the later Colchester fabric, it is likely that the latter is of later date. The nearest parallel in form is the beehive-shaped louver from London which occurs in a context of c 1360 (Pearce *et al* 1985, 50, fig 80.446). On this basis, and in the lack of closely-dated parallels for the slip-painted designs, a date of c 1350-75 or thereabouts is proposed for the East Stockwell Street louver (Fig 106.244). The Angel Yard louver (Fig 107.245) was discarded or broken in the 15th or early 16th century, judging from its contexts, and was not particularly weathered by exposure at this time, suggesting it may not have been very ancient when broken. The fabric and painted slip

designs, particularly the sub-Rouen/Mill Green-style white pellets, are similar to the 'middle style' of slip-painted Colchester-type ware (see Stratified Groups 9 and 10), and on this basis a date of c 1375-1425 is suggested.

One other possible beehive-shaped louver (Fig 108.246) has a crude but exuberant frieze of slip-painted foliage which resembles very closely the foliage designs of late 14th- and early 15th-century Colchester-type ware and could be of this date itself, despite coming from a late 15th- or early 16th-century context.

Several Colchester-type louvers have been found in contexts associated, although indirectly, with detached kitchens and hearths. At Great Easton, the louver there appears to have been associated with a detached kitchen with a central hearth and a baking oven (Dunning 1966a, 74). At the Middleborough site in Colchester, fragments of up to five separate louvers were found scattered in and around two adjacent medieval tenements (CAR 3, 189-209) which had central hearths and peg-tile ovens, and by the 15th century one of these buildings had a detached kitchen with a circular peg-tile oven (Building 75, *ibid*, fig 179). There was also some evidence for a late medieval chimney with a stamped clay fireback (*ibid*, 194-5). One louver fragment from the backyard of this building (MID CL161) and a second fragment to the south of the building (MID CF115) lay around 5 m and 10 m east respectively of the detached kitchen, although they could equally have been derived from positions above any of the hearths.

It may be significant that the East Stockwell Street louver was stratified in contexts directly above a medieval peg-tile oven. At Angel Yard, there is similar evidence for medieval tenements and circular peg-tile ovens, but it is uncertain whether these ovens stood in detached kitchens.

Fragments of three louvers came from the medieval (12th-century) stone tenement on the corner of Lion Walk and Culver Street (Buildings 28 & 29; CAR 3, 75-82), which produced evidence of hearths in service rooms attached to the south of the building; and a detached building (*ibid*, Room 8), possibly a kitchen, existed by the 16th century. All three louver fragments are of the earlier type with all over external slip and green glaze. These included the truncated conical finial (Fig 108.247) and a large piece from the curved dome of a louver with a frilled cordon (LWC G235, not illustrated).

Several fragments of the Chelmsford louvers may have been reused in a probable detached kitchen in use c 1590-1630. They were weathered and soot-blackened around the vents (*ibid*, 213).

It seems fairly clear that pottery louvers are commonly associated with the houses of reasonably well-to-do citizens and generally with the upper orders of medieval society. They are known from country manors such as Great Easton and the Manor of the More, Rickmansworth (Dunning 1966a), as well as from royal properties such as Hadleigh Castle (Drewett 1975). In Colchester we can only guess at the identity of the citizens concerned, and suppose that they included people such as prosperous merchants and local government officials.

The East and West Stockwell Streets area, where two of the finest louvers were found, was regarded as the town's 'Jewish quarter' (later called 'Dutch Quarter'), but as the Jewish community in Colchester was non-existent by the start of the 14th century they cannot have been responsible

for these particular louvers. The area did contain a number of stone houses which were owned by Jews in the 13th century and these would have remained valuable properties after their departure (see p 18; Stephenson 1984-5). Whatever the identity of the owners, the presence of so many louvers on the roofs and chimneys of town houses and detached kitchens must have been an impressive sight for visitors to medieval Colchester.

Roof finials and other roof furniture  
(Fig 108.250, 252-254, Fig 109.255-256 & Fig 110)

A number of sherds from the excavations are tentatively identified as roof finials but most of these are small and uninformative. These include Figure 108.252, a wheel-thrown cylinder made in two sections which were then luted together. The exterior is covered with white slip under a green copper-flecked glaze. Sherds of Mill Green ware (c 1270-1350) were associated in the same pit. Figure 108.253 has been mentioned above and probably represents the lower flange and socket of an unglazed bulbous finial. The socket or locator, which would have allowed it to be slotted into a roof, has been vertically knife-trimmed and the whole object is probably hand-made. It was associated with a slipped sherd of 13th-/14th-century Colchester-type ware.

A more informative collection of Colchester-type roof finials, one zoomorphic and three anthropomorphic, is kept in the Colchester Museum. Two of these were illustrated by the late G C Dunning (Figs 108.254 & 109.255) as part of a survey of medieval roof furniture that was never completed.

The zoomorphic finial (Fig 108.250) represents a snarling dog, probably a hunting dog such as a wolfhound or greyhound, with a collar round its neck and attached to a lead. It is of wheel-thrown conical form with the head either applied or formed from surplus clay. The head has been modelled with sunken pits for eyes and sharp teeth suggested by a row of stabbing made with a triangular-pointed tool. The ears (now missing) may have been pinched out, and the collar and lead are formed from two separate strips of applied clay. A thick patchy white slip covers the exterior and this has then been covered with a clear greenish glaze. This unusual finial may originally have been attached to a ridge-tile. The upward direction of the lead suggests that the other end may originally have been held by the dog's master, possibly a mounted figure of the more common 'horse and rider' form (Dunning 1974, pls 12-16); though in this case, unusually, with hunting dog running alongside. The finial, which may be 13th or 14th century, was found at Bourchier's Hall at Aldham near Colchester, a manor owned in the 14th century by the family of that name who eventually became earls of Essex (Morant 1768, 2, 197-8).

The king-shaped finial (Fig 108.254) came from the site of the Old Police Station in Queen Street (formerly King Street). Although unaccessioned, a short description and photograph were published at the time of its discovery (CMR 1944, 49 plate 10), where it was described as being 'modelled on the coins of the early Edwards'. A recent, more detailed photograph has also been published (Stephenson 1978, 54). It was thrown as a cylinder with a bulbous upper part for a head on to which facial details were applied and modelled. Eyes and mouth have been pierced through to the inside; the applied nose is missing. Detailing on the face, hair and beard appear to have been incised sgraffito-style through the cream slip which covers

the whole exterior which was then covered with a thin green-flecked glaze. Above the arm stumps, a deeply incised horizontal groove suggests the hem of a tunic. On the head of the finial sits a broken truncated crown and at the top of the head is a large circular aperture closed by a crude lead stopper with an iron stock. The stopper on the king-shaped finial might once have been provided with a ceramic finial of its own; finials on finials, in fact. In the case of the king, a cross or an orb surmounted by a cross would have made a suitable apex for a crown. Dunning has illustrated a king-shape finial from Chichester, Sussex which is similar to, but more stylised than, the one from Queen Street in Colchester. He dates the Chichester finial to the 13th century (Dunning 1961b, fig 5.1.1).

A second anthropomorphic finial (Fig 109.255), from Culver Street, represents the lower part of a wheel-thrown figure attached to a ridge-tile. Down the front of the figure a row of small circles, suggesting buttons, are impressed through the white slip, and higher up there are traces of the start of an arm. The whole piece is covered externally with a thick white slip under a green-flecked glaze. It probably dates to the 13th or early 14th century.

The third anthropomorphic finial (Fig 109.256) is in a coarse oxidised Colchester-type fabric and represents a human head made as a solid plug or stopper which was probably designed to be plugged into a ridge-tile. Although quite abraded, the whole of the face area was evidently covered with a thick white slip under a clear glaze, but only patches of this now remain. The area below the face, including the broken cylindrical shaft or plug, is unglazed. Facial details are crudely modelled and the holes for the eyes and ears have been very deeply pierced, probably to facilitate an even firing. Part of the nose, the lower lip and chin (which may have been bearded) are missing. The mouth appears to have been formed by two deep horizontal knife-slashes and the projecting lips either applied or formed from surplus clay. It is evident that there was once a tongue, only the stump of which remains, and this seems likely to have stuck out and curled downwards to rest against the chin where there is now a smooth, roughly square grey area. In the top of the head is a deep square-sectioned socket, possibly for the attachment of a hat either of ceramic or other material. The shaft or plug below the head has vertical knife-facetting. The head was recovered as a surface find on ploughed land at Barnston, near Great Dunmow, 20 miles west of Colchester. A 13th- or 14th-century date again seems likely.

### Sgraffito ware

[Figs 111.257-267 & 113.268-286, Fig 112, & Pl 6]

A small but distinctive element of the Colchester-type assemblage is decorated in the sgraffito technique, whereby designs are incised through a white slip to contrast with the underlying red fabric. The vessel is then covered with either a green copper-flecked glaze or, more usually, a clear glaze, or sometimes it is left largely unglazed. The excavations produced at least 51 such sherds (0.37% of the whole Colchester-type ware assemblage; or 15%, by weight, of all over-slipped vessels). Many others are known from earlier collections in Colchester Museum and from sites awaiting study.

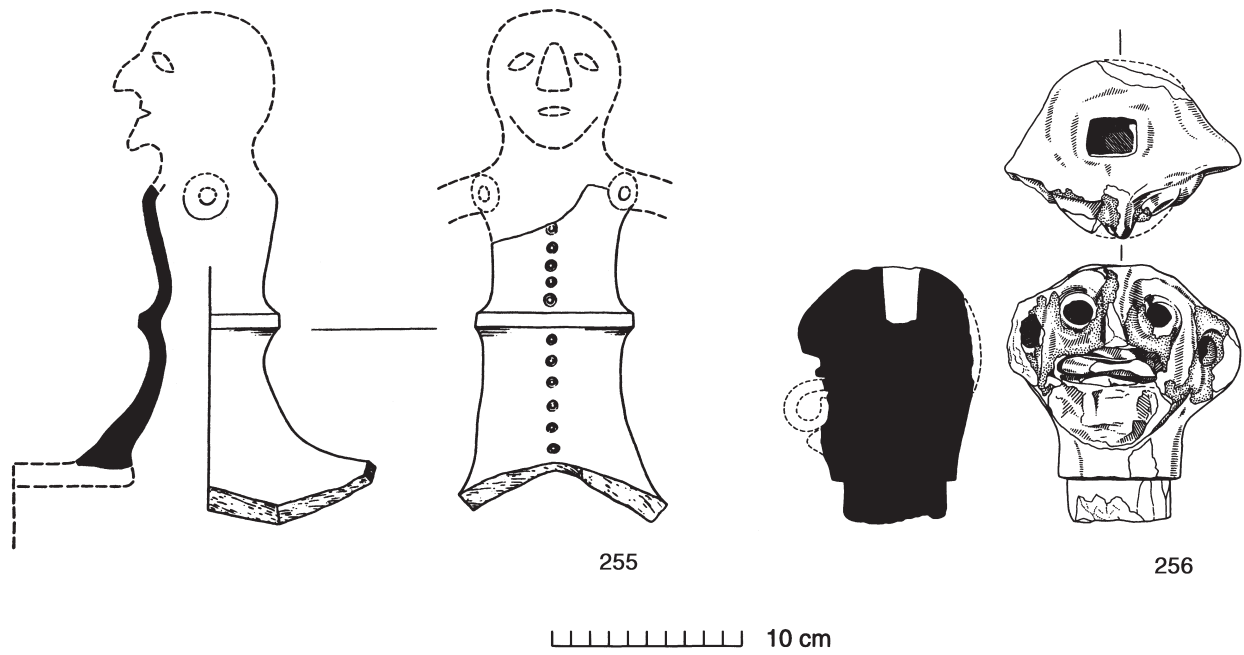

Fig 109 Colchester-type ware: finials (nos 255-256). 1:4.



Fig 110 Colchester-type ware: roof furniture — the East Stockwell Street louver and two anthropomorphic finials, 14th century (surviving height of louver 595 mm).

Sgraffito wares of this type, dating from the 14th and 15th centuries, are best known from Cambridgeshire (Dunning 1950; Bushnell & Hurst 1953), where some of the most competent English medieval sgraffito ware was undoubtedly made. Cambridgeshire sgraffito appears to have been a small element of the local East Anglian redware tradition. It would be surprising, then, if other known or suspected production centres within this tradition did not also include a small sgraffito element in their repertoire. Small numbers of sgraffito sherds turn up on excavations throughout Essex: eg at Chelmsford (Cunningham 1985, figs 10.71 & 40.9); Writtle (Rahtz 1969, fig 54.42-8); Rivenhall (Drury *et al* 1993, fig 45.185-9); the moated site of Maidens Tye, High Easter (Walker 1988a, fig 10.76-9); Hadleigh Castle (Drewett 1975, fig 20.181); and many other locations.

Among the small collection of Colchester-type ware wasters from the 14th- to early 15th-century kiln-site at Great Horkesley (see above pp 109-10) was a single sgraffito-decorated sherd (Fig 113.286). This has the normal Colchester-type fabric but is an overfired purple-red with an irregular grey-blue core and a leached white slip under a thin clear glaze, and it is thus almost certainly a waster and perhaps the most conclusive evidence for the local manufacture of sgraffito ware. Although one cannot rule out the possible presence of one or two sherds of true Cambridgeshire sgraffito among the excavated material, there seems little reason to doubt that the majority of sgraffito sherds from the town are products of the Colchester-type industry. True Cambridgeshire sgraffito generally occurs in a smoother, finer red fabric. However, the fabric from the excavations is, in most cases, identical to early Colchester-type ware. All the sgraffito rim forms and some decorative elements (eg applied thumbled spirals) can be directly paralleled in the local industry. The bulk of sgraffito designs show no high degree of sophistication and could hardly have been beyond the capabilities of an ordinary potter working within a slipware tradition. Given these facts, the only surprise is that the technique was not more widely employed.

The sgraffito material from Colchester is rarely complete enough to ascertain the form of the vessel or, in most cases, the overall design, but consists largely of tantalising, often unintelligible fragments. A sgraffito technique is sometimes used in combination with applied and modelled decoration, as on the anthropomorphic masks found on chafing dishes (see above, Figs 100-101), on roof furniture (see above, Fig 108.254), and on a pedestal-base anthropomorphic cup (Fig 99.192). These 'complementary' instances of the sgraffito technique are largely excluded from this discussion which concentrates on those instances where the sgraffito design is the major decorative element of the vessel. Excluding this 'complementary' category, the designs that occur are largely derived from vegetation (Figs 111.260, 262, 264-266 & 113.269, 272, 274-277), or are geometric (usually borders or friezes: Figs 111.259, 263 & 113.268, 273), while a few may be 'merchant's marks' (Figs 111.258, 267 & 113.285) or anthropomorphic (Fig 111.257), and in one case inscriptional (Fig 111.261), with the remainder comprising a variety or abstract or unintelligible designs. A small number of sgraffito tiles have also been found in the town. These occur in a coarse Colchester-type fabric and include anthropomorphic and mythological designs (CAR 6, 260-61, fig 7.3).

Distinguishable forms with sgraffito decoration include a probable baluster jug (Fig 111.257) with a childish design of

a human bust wearing a broad floppy hat (perhaps a young apprentice's doodle?). The squat jar-like jug with green-flecked glaze (Fig 111.258, Pl 6) has an applied spout with a corresponding slot cut from the rim and is almost certainly a copy of the Saintonge *pégau* or wine jug form (see Fig 174.7). The 'merchant's mark' on its side is similar to a number of East Anglian merchants' marks of the late 15th and 16th centuries. Two similar slipped rims are among the excavated material (Fig 89.105), including an identical spout fragment (LWC LF114) sealed by a pit containing a Raeren stoneware mug (c 1475-1550). Squat jugs are undoubtedly represented among the more fragmentary items (Fig 111.260-262). Large storage jars and perhaps cisterns too are represented by typical Colchester-type 'cornice' rims (Fig 111.263-264) and an applied thumbled spiral (Fig 111.266). A similar jar from the 1986-7 Angel Yard site (40.86 545) has a simple shoulder frieze of vertical, spiky 'palm trees' (as Fig 111.265). The wavy line and flanking 'palm trees' of Figure 111.266 are also paralleled on the Angel Yard jar. It is also clear from other sherd examples in Colchester Museum (CM 40.3811 844) that motifs such as 'palm trees' and other branching motifs (as Fig 113.280-281) may occur in the centre of applied spirals. An unusual lid is also present (Fig 113.273).

Several bowl-like pieces are most probably from chafing dishes (Fig 113.268-272), and Figure 113.271, with its slot and perforation, is almost certainly a chafing dish. Figure 113.270 has traces either of a perforation or of a fluted base. Both nos 269 and no 272 have a green-flecked glaze and a quatrefoil design and may come from the same vessel. With the possible exception of no 271, with its perforated bowl, the original form of these chafing dishes may have been similar to a largely complete sgraffito chafing dish from Chelmsford (Cunningham 1985, fig 10.71) and to other, non-sgraffito examples from late 14th- and early 15th-century contexts in Colchester (see above).

Figure 111.267 represents one unit of a two-part condiment set, possibly wheel-thrown and subsequently flattened in order to lute it to a similar flattened unit of which only a large blank scar remains. The floor appears to have been added or repaired after flattening. On the outer face a trace of a sgraffito symbol survives, possibly a 'merchant's mark'. The fabric of this piece is relatively underfired, quartz-free and micaceous, and it may not be a Colchester product.

Probably the most interesting sgraffito item is the inscriptional sherd which comes from the shoulder of a squat jug (Fig 111.261 & Fig 112). This is in a very sandy oxidised Colchester-type fabric with a grey core in places. The exterior is covered with a smeared white slip under a clear glaze with greenish tones. At least two lines of writing have been incised through the slip though only the word '*potter ...*' on the second line can now be read. The 'Y'-shaped letter to the left might represent 'ye', or alternatively this and the group of marks to the far left of the sherd may be part of a design or 'merchant's mark'. It is likely that the first line represents a personal name of which the first two letters are '*Sy ...*' (?Symon) or '*Fy ...*' and which possibly includes '*...dn ...*' as the last two readable letters, perhaps part of a surname. At the neck/shoulder angle, the lower part of a loop survives, possibly part of wavy line decoration on the neck of the jug.

The inscriptions on this sherd were submitted to a palaeographer, Miss Jo-Ann Buck, for her comments. Miss Buck observed that the inscription is in quite a good hand,

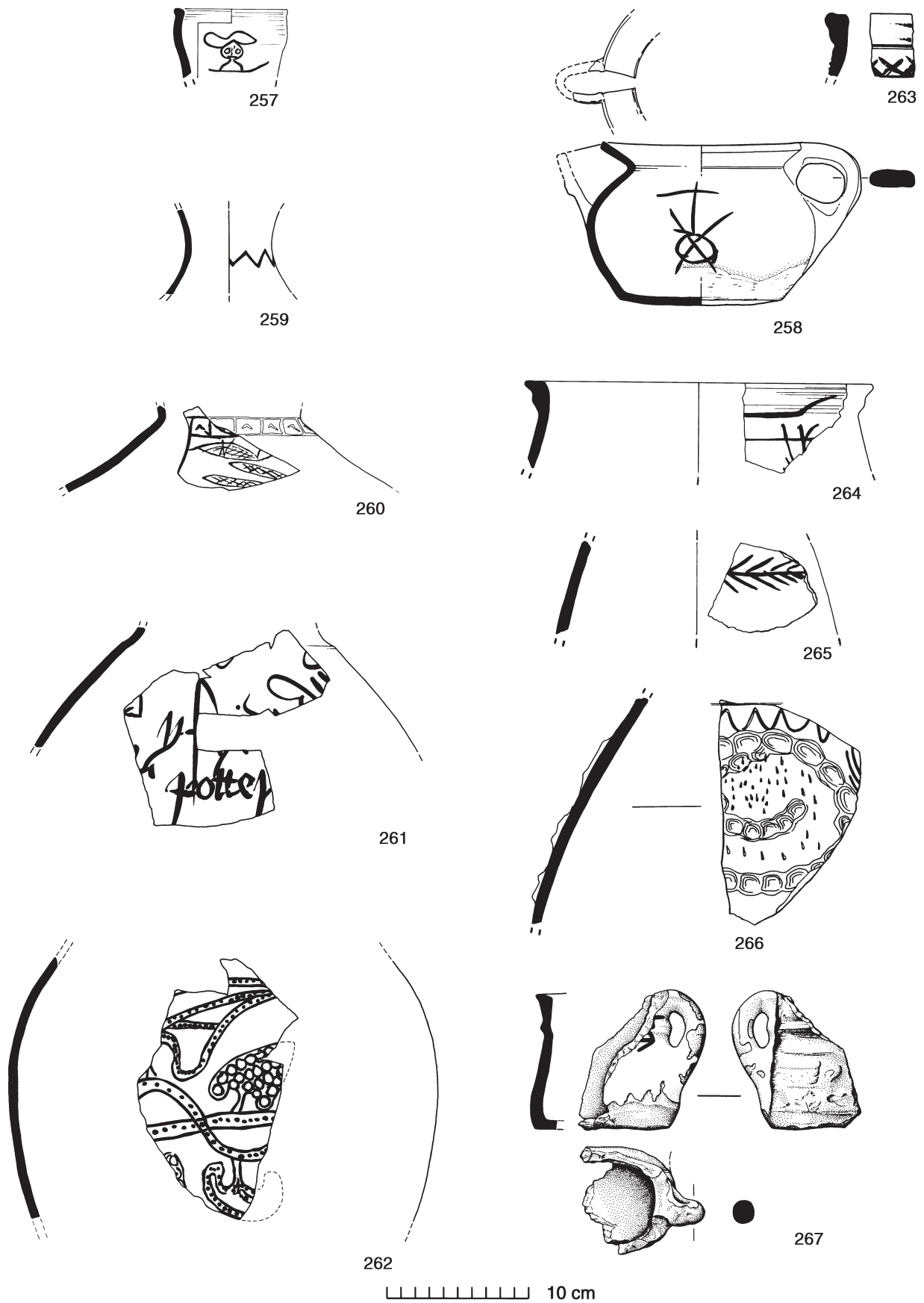

Fig 111 Colchester-type ware: sgraffito-decorated forms — jugs (nos 257-262); jars or cisterns (nos 263-266); condiment (no 267). 1:4.

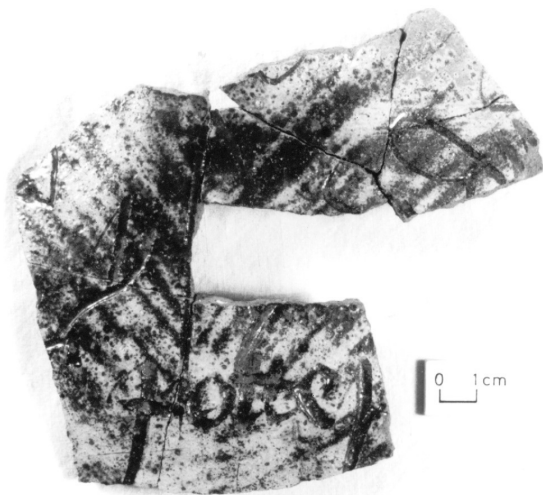

Fig 112 Colchester-type ware: sherds from squat jug (no 261) with sgraffito 'Potter' inscription.

apparently 'court hand'. The style of the long 'r' and the 'e' of 'potter' would not generally be current after c 1550. 'Court hand' had a long currency from the 13th to the 16th century. Other palaeographers have suggested an early 16th-century date (Richard Cross, pers comm). The fabric, for what it is worth, is not particularly late in character, and a date of c 1400-50 is suggested, though on no very firm evidence. The seven joining sherds which make up the fragment were the only pottery at the bottom of a sequence of late medieval/post-medieval occupation layers and floors belonging to a group of buildings on the corner of Osborne Street and Stanwell Street. One area here had a floor of glazed (?Flemish) tiles typical of 15th- to 16th-century Colchester houses (see above p 5) and which sealed the sequence containing the sgraffito jug.

Medieval pottery vessels with inscriptions are extremely rare in Britain. Dunning (1967) reported on three inscribed late medieval jugs, two with stamped lettering from the Midlands and one with incised freehand lettering from Spilsby, Lincolnshire (*ibid*, fig 70). The Spilsby jug is of 15th-century date and bears the word 'Binedice' incised (though not sgraffito-fashion) on the shoulder. The meaning of the stamped lettering on the other jugs is more obscure, but Dunning concluded that all three jugs bore protective formulae connected with a widespread Midlands-based pre-occupation with witchcraft. The closest parallel for the Colchester jug, however, is with a sgraffito-decorated squat jug from the Rye kilns in Sussex (Barton 1979, 196, 199, Rye ware fig 2.0). This jug is decorated with fish, and bears part of the alphabet incised in a style dated to c 1300-50. A 13th-/14th-century cooking pot from Norwich (perhaps used as an acoustic jar) bears a post-firing inscription, possibly signifying Adam and Eve, but this was probably executed by the owner rather than the maker (Jennings 1981, fig 16.317).

The very few inscribed ceramic vessels that are known thus appear to have vaguely religious/superstitious associations, although the real significance of these inscriptions is probably capable of a number of interpretations. Whether or not the inscribed Colchester jug had similar associations is entirely unknown, but the buildings that sealed it appear

to have been ordinary domestic properties. The site of St John's Abbey lies about 150 m to the south, while the Magdalen Street pottery kilns (active c 1450, see above p 110) were around 300 m to the south-east. A connection with either location, or both, is possible. What remains of the inscription permits only a limited interpretation of its significance, but it would seem to be the product of a literate late medieval potter perhaps taking pride in his work and signing it with his name. Alternatively the inscription could be a forerunner of those inscriptions on post-medieval pots inviting the reader to reflect upon his mortality which ends in clay. The fact that a late medieval Colchester potter should be literate also raises questions about the educational and social status of medieval potters in general.

A remarkable highly decorated lid (Fig 113.273) came from a mixed 16th-/17th-century context. The lid is covered all over with a streaky white slip under a clear glaze. On the upper surface a raised flange (possibly applied) has been cut away to produce a series of crenellations or crests. A variety of stamped and incised decoration covers the external surface, including small circular dots and ring-and-dot stamps on the sides, dot stamps on the knife-cut facets between the crests and behind them, and rows of ring-and-dot and crescent stamps on the upper surface separated by incised horizontal lines. The knob is missing. There is a remarkably similar lid in Surrey/Hampshire Border ware from London (Pearce 1992, fig 45.442, pl 6) and a similar, but not identical, lid from the Cove production site in east Hampshire, dated to the second quarter of the 17th century (Haslam 1975, fig 10.127).

The majority of Colchester sgraffito sherds fit the conventional 14th- and 15th-century date ascribed to Cambridgeshire sgraffito (Bushnell & Hurst 1953). The earliest stratified example (Fig 113.284, Period 3.2) was associated with late 13th- or early 14th-century pottery including Colchester polychrome ware (see above, pp 124-6). An early 14th-century date for this layer seems more probable. The fabric of this piece is reduced and clear glazed with a few copper-green flecks. The fragmentary sgraffito design, unless a 'merchant's mark', is little more than a doodle. Three sgraffito sherds, including a possible 'merchant's mark' (Fig 113.285), came from the town wall context of c 1382-1421 (Stratified Group 9). Thereafter, a thin scatter of sgraffito sherds occur in contexts as late as the mid 16th century. Because they nearly always occur as isolated sherds, it is likely that many sgraffito sherds may be residual in their contexts. The overall impression is that sgraffito decoration, like the use of all over white slip and green glaze, was primarily associated with the earlier production period of Colchester-type ware. The use of all over slip may, however, have continued on a small scale to allow the production of sgraffito wares until about the middle of the 15th century, if not slightly later. A jug from Hadleigh Castle with a crown-like sgraffito 'merchant's mark' on the front is dated to c 1475-1525 (Drewett 1975, fig 20.181).

Unusual Colchester-type forms with 'complementary' sgraffito decoration, such as the anthropomorphic pedestal-base cup Figure 99.192 (Stratified Group 15, c 1525-50), were almost certainly still in production in the early 16th century; and the unusual crenellated lid Figure 113.273 could date much later in the century. While there is therefore some evidence that the 'complementary' sgraffito technique survived well into the 16th century, there is no firm evidence that the 'primary' technique survived as late as this.



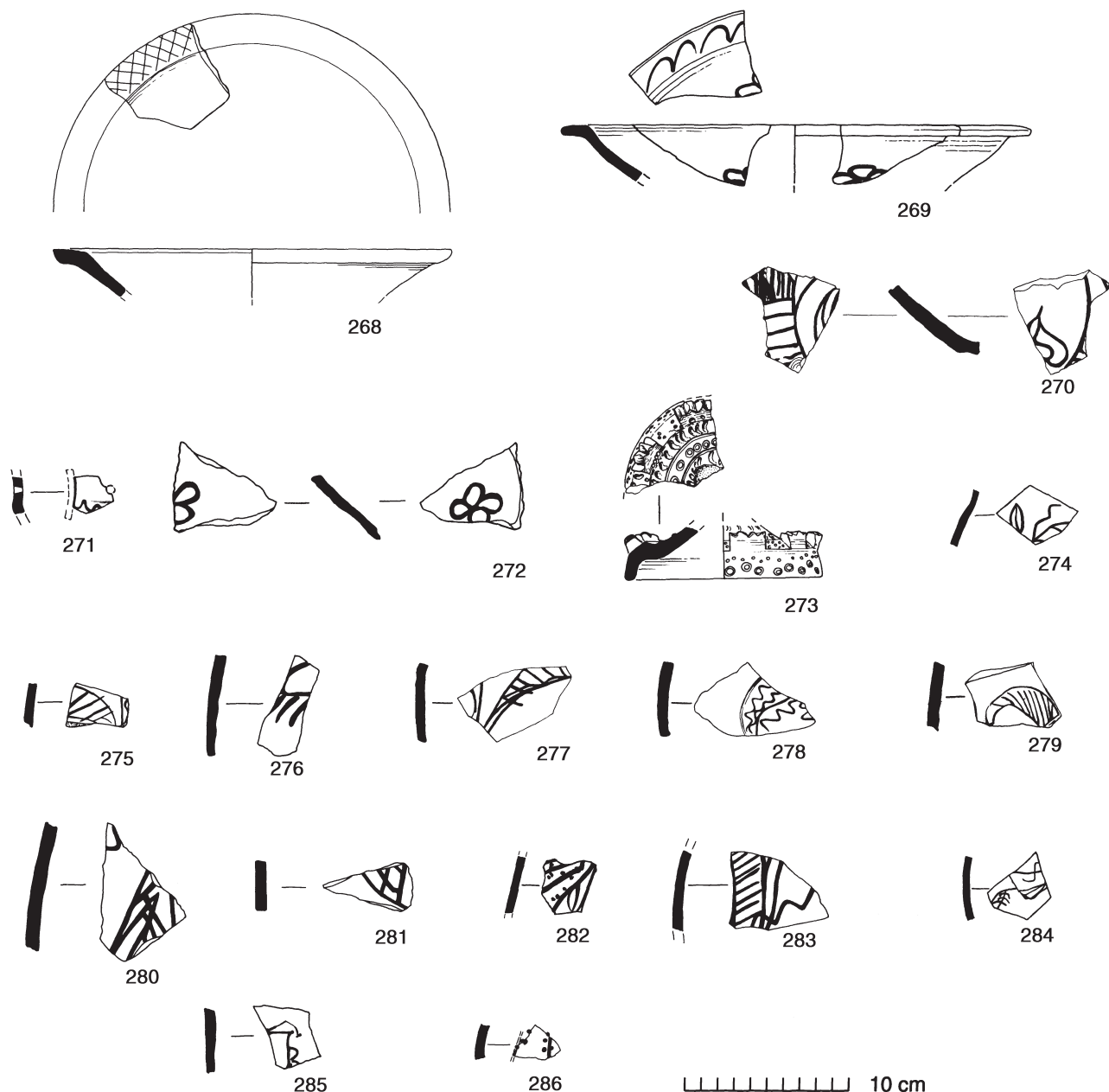

Fig 113 Colchester-type ware: sgraffito-decorated forms — chafing dishes (nos 268-272); crenellated lid (no 273); miscellaneous sherds (nos 274-286). 1:4.

**Slip decoration: an outline of its stylistic development on Colchester-type ware**

[Figs 114-15 & 120]

The use of white slip on any vessel made of red clay was primarily for decorative reasons, whether as a background or for fully-fledged slip-painting. Between 30 and 40% of the whole excavated assemblage of Colchester-type ware has some form of white slip decoration (30% weight; 37% EVEs). Figure 114 (slip usage) illustrates the percentage of Colchester-type ware that was slipped (in any style) in each

successive period. Only two sherds of the ware were present in Period 2.2-4 (c 1100-1200), and both were white slipped thus giving the exaggerated figure of 100%. A more reliable picture is presented by the Periods 3.1 to 4.2 assemblages with their considerably larger numbers of slipped sherds. Thus the 50 slipped sherds in Period 3.1 contexts (c 1150/1200-1250/75) represent 27% of Colchester-type sherds from those contexts, rising to a maximum of 48% in Period 3.2 (c 1250/75-1400) and dropping thereafter. The drop after this period is almost certainly a reflection of the decline of all over slip decoration and its replacement with linear slip-painted decoration which produces fewer slipped sherds per vessel than the former technique.

Broadly speaking, the different techniques (as opposed to styles) of slip application on Colchester ware may be divided into three: all over slip, applied plastic or thickly painted slip, and thinly painted slip. Their relative frequency throughout the lifetime of the ware is shown in Figure 115, for which percentages based on sherd counts seem to provide the clearest picture of events, while weight differs only slightly. The main trend is clearly the gradual replacement of the early style of all over external slip and applied plastic slip techniques with the later slip-painted technique. The surprisingly high figure of all over-slipped sherds still present in Period 5.1 (c 1550-1600) may be explained in part by residuality and also by graphical exaggeration, there being only fourteen slipped sherds in this period. Similarly it should be borne in mind that Periods 2.2-4 and 2.4 are represented by only three slipped sherds. These different techniques of slip usage largely correspond to the different styles of slip decoration on Colchester-type ware synthesised below. All interpretations given are based on personal observation largely supported by the data.

*Early style (c 1200-1375/1400 (PIs 2-3, Figs 72 & 81))*

The assemblage at this time is dominated by jugs, many of which are covered externally with white slip down to a short distance above the base and often around and partially inside the rim (eg PI 2 & Fig 71.1-4, 6-7, 9-10). The other main type at this time was applied plastic or semi-plastic white slip. This was smeared on, probably with the fingertip, and used to create linear decoration or pellets. Typical decorative schemes include simple vertical or horizontal strips (Figs 71.5, 73.11 & 82.55); geometrical arrangements (Figs 72, 73.13 & 82.60), including the 'Rouen' style (PI 3 & Fig 81; Fig 82.51-53) and the related Mill Green polychrome style (PI 4 & Figs 73.12, 82.56-58); and perhaps stylised vegetation (Fig 73.14). There is no sharp distinction between 'applied' slip and 'painted' slip. The difference lies in the consistency of the original slip and the degree to which it was smeared or painted on. The early smeared slip is noticeably thicker, standing in low relief and having a tendency to chip. It is normally glazed and appears yellow. In contrast, late slip painting is typically thin and flat, almost soaking into the underlying fabric and almost always unglazed and thus remaining white. Applied or smeared slip slowly developed into true thin slip painting but a percentage of thinner slip-painted vessels already existed in this period and continued to grow.

*Middle or transitional style (c 1375-1450 (PI 5))*

This is not clearly separate from either the early or late style but is a transition from one to the other. Nor is it sharply defined chronologically but hinges around this date, although certain characteristics of the style may have begun earlier or lasted later. This period is marked by an increasing economy in the use of slip. The old scheme of over all external slip disintegrated into broad isolated zones of slip. Jugs and jars often received just a broad slip bib around the frontal upper half of the vessel (Figs 79.42, 44 & 85.79, Stratified Group 9; Fig 222.33, Stratified Group 11; Fig 225.6). Broad circular or laurel leaf-shaped bibs may have developed into painted motifs such as fleur-de-lis or circular and wheel-shaped motifs (Figs 73.15, 75.27 & 89.106; Stratified Group 9, Fig 221.35-36). A broad zone or band of slip coverage was often retained around the neck

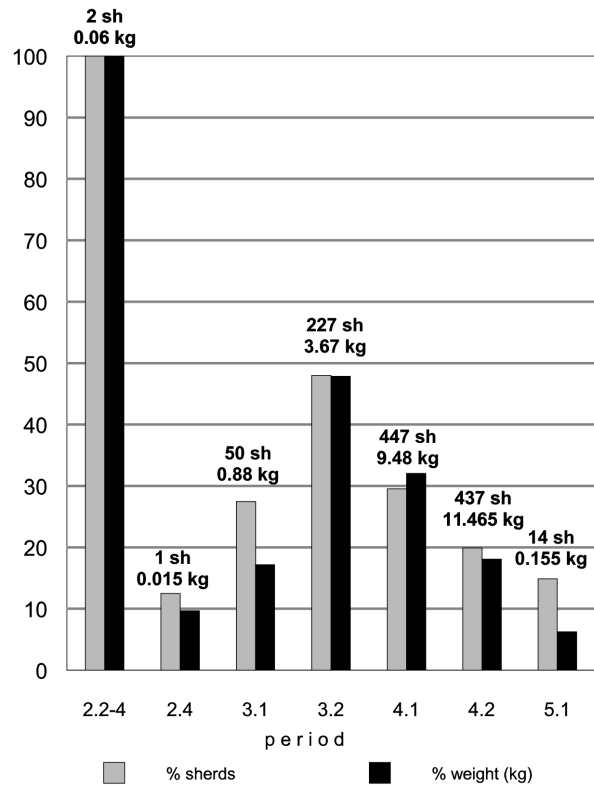

Fig 114 Colchester-type ware: bar chart showing percentage with white slip in stratified contexts (ceramic periods; Colchester-type assemblage = 100% in each period).

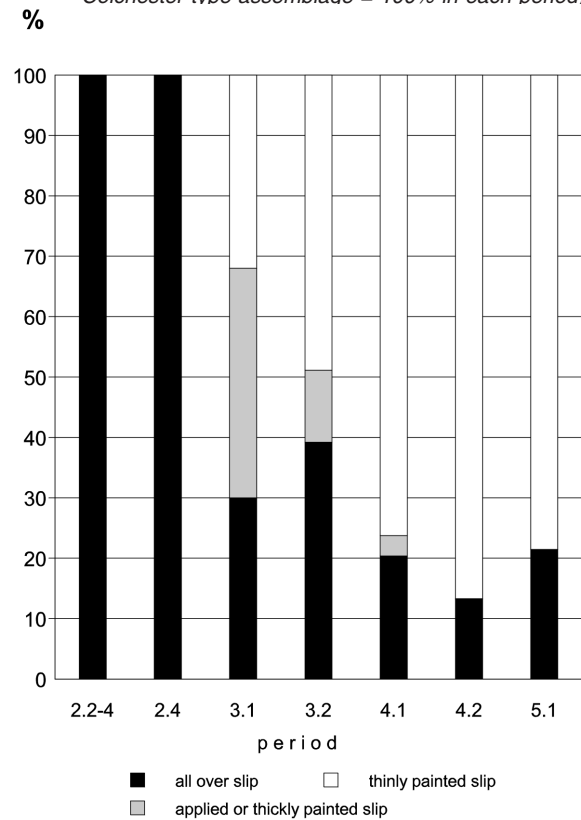

Fig 115 Colchester-type ware: bar chart showing the relative frequency of slip application techniques in stratified contexts (ceramic periods; the slipped Colchester-type assemblage = 100% in each period).



Fig 116 Colchester-type ware: group of miscellaneous forms, mostly plain, 14th-15th century (height of jug to bottom right 232 mm).

and rim of the vessel or on the inside of the rim (Figs 74.18, 75.25-26 & 78.32-33). Jugs sometimes have a horizontal slip band on the rim which may be accompanied by a stripe down the centre of the handle (Fig 74.18, Fig 78.32-33), a scheme common on East Anglian redwares in general.

Simultaneously applied or smeared slip decoration disappeared, having now developed into true slip painting. By the start of the 15th century, late characteristics such as slip dashes on the rim (Figs 73.15 & 75.27) and painted foliage had appeared. Early to mid 15th-century slip painting appears to have more variety and individuality than the fossilised schemes later on in the century. Its designs have a high medieval flavour and include fleur-de-lis and running scrolls (Figs 73.15, 74.18, 75.25, 83.64 & 91.126-127). The wheel design of Figure 75.27 is known from more than one context of the late 14th or early 15th century including Stratified Group 9 of c 1382-1421 (Fig 221.35-36). Merchants' marks typical of the later 14th to 16th centuries sometimes occur (Fig 74.19). To this period also, but perhaps mainly to the early to mid 15th century, it seems possible to assign a few designs that appear to be unique to Colchester ware. These include some large squat jugs with broad triangular designs internally subdivided and with cross-shaped fillers (Fig 78.31-32). Other designs probably belonging to this period include rosettes (Fig 83.61), crosses (Fig 224.48, Stratified Group 10, c 1400-50), perhaps arcaded friezes (Figs 83.63 & 107.245), and perhaps most of the line and dot designs ultimately derived from a debased Rouen-style decoration (Figs 82.54, 59 & 83.64 and particularly of Cunningham 1982a, figs 30.60 & 31.62).

Certain specialised forms such as 'Cheam copy' jugs (Fig 80) continued the 'early style' all over use of white slip in an effort to resemble true Cheam white wares, but the jugs were now dipped in a bath of thin liquid slip rather than

wiped or painted all over with thicker 'early style' slip. A few 'metal copy' baluster jugs and sgraffito-decorated vessels also employ all over slip until the end of this period.

#### Late style (c 1450-1525/50) (Fig 117)

This phase is typified by the complete dominance of exuberant thinly painted slip decoration. The variation which characterised the middle style was superseded by a standard frieze of spiky foliage usually bounded by two horizontal lines and accompanied by slip dashes on the rim (eg Figs 75.29-30, 85.83 & 86.84-85). This is the hallmark of late Colchester-type ware. A smaller number of vessels have a loose abstract scheme of slip painting; ultimately derived, perhaps, from increasingly stylised vegetation (Figs 78.34, 36 & 87.89, 91). As a rule, slip painting was confined to jugs and jars, while bowls were almost invariably plain. A few 'middle style' non-standard designs, such as hoops, continued in production (Figs 79.37 & 90.114).

To a very small degree, total coverage with white slip appears to have continued even as late as the 16th century but this was on peripheral forms, mainly those with 'complementary' (as opposed to 'primary') sgraffito decoration, and a few strainers (Fig 103.208), fuming pots (Fig 103.212), and a single bowl (Fig 94.155). It was observed, particularly when comparing pit groups of the earlier 15th century with those of the early 16th century, that the percentage of vessels with slip painting had decreased. This is reflected in Figure 114 and gives the impression that the practice of slip painting may have died out during the second quarter of the 16th century, some time before the eventual disappearance of the industry around the middle of the century.



Fig 117 Colchester-type ware: group of miscellaneous late forms, some with slip-painted decoration c 1475-1525 (height of centre rear cistern 306 mm).

### Colchester-type ware: origins, affinities and decline

The decline or transition of the early medieval sandy ware (Fabric 13) industry at the end of the 12th century appears to have given rise first to a harder-fired sandy greyware (Fabric 20), and then to a similar oxidised ware which we now know as Colchester-type ware. Both new wares can to some extent be regarded as components of the same industry; their fabrics are petrologically very similar and there is some evidence from the Great Horkesley kiln-site just outside Colchester that they were produced in the same place (see above, pp 109-10). For most of the 13th and part of the 14th century, the unglazed greyware element of this dual industry dominated the market for cooking pots, jugs and other kitchenwares. Colchester-type ware, the oxidised ware, seems increasingly to have catered for the need for glazed tablewares and developed in new and different ways from the greywares. After a slow start, the production of Colchester-type ware gathered pace in the later 13th century; and perhaps by the middle of the 14th century or slightly later (Period 4.1, c 1350/1400-1500, Fig 247), production outstripped that of the greywares, aided perhaps by a decline in the demand for large cooking pots as metal ones took their place. With its staple product no longer in demand, the greywares could not compete with the visually more attractive Colchester-type fabric with its glazed and slip-decorated jugs. Even the range of kitchenware forms produced in Colchester-type ware were probably a more attractive substitute for metal-ware vessels than greyware ever could be.

Early Colchester-type forms reflect to some extent their close connection with the greyware industry. A large squat jug/cistern of c 1250 (Fig 84.73) has exactly the same form and hand-made construction as greyware squat jugs with ribbed necks (c 1175-1250/75). White slipped Colchester-type baluster jugs commonly exhibit the same distinctive inturned or carinated rim found on greyware squat and pear-shaped jugs, although this might reflect a mutual influence from Mill Green ware jugs (see below). In general, however, Colchester-type jug forms and methods of decoration are quite different from the greyware forms. Early Colchester-type bowls clearly copied the straight-sided, flanged-rim form of late greyware bowls (c 1250/75-1400); and the type of small flanged-rim cooking pot common in Colchester-type ware in the late 14th and 15th centuries (Fig 91.123-125) was either copied from the small 14th-century greyware form (Fig 59.11-12), or the latter may represent an attempt by the greyware industry to copy a newly introduced Colchester-type form and thus remain competitive.

The earliest outside influences on Colchester-type ware were probably from Hedingham ware, produced fifteen miles to the west of Colchester, and from London-type ware, produced 50 miles to the south-west. Because of the fragmentary condition and small size of the sample, the form of the very earliest Colchester-type jugs remains uncertain but probably included medium-sized rounded jugs, squat jugs and baluster jugs copied from either or both of the previous two industries. Despite the proximity of Hedingham, the influence of London-type ware was probably

stronger. The earliest stratified sherds of Colchester-type ware, which are possibly late 12th century, are from white slipped jugs with either a clear or a copper-flecked green glaze. All over white slip does not occur on Hedingham ware jugs and at this date the technique could only have been copied from London-type ware, which included white slipped jugs in its 12th-century output (Pearce *et al* 1985, 27, 129). Colchester-type jugs copied Rouen-style decoration either from London-type or Hedingham ware (Alan Vince, pers comm; see Fig 82.50-53), and it is unlikely that the style would have been copied from London without also copying (if only loosely) the baluster-jug form with which it was closely associated (*ibid*, figs 25-31). The rod handle of London Rouen-style baluster jugs was sometimes copied (Fig 83.70), but the typical Colchester-type narrow strap handle with deep central furrow, alien to London jugs, was also used on larger Colchester-type jugs decorated in this style (Fig 82.51). Polychrome Rouen-style decoration employing red and white slip is confined to only one or two early Colchester-type vessels (Fig 82.50, 51), but was soon dropped in favour of white slip decoration only.

It is difficult to point to unambiguous evidence of influence from Hedingham ware as the latter was itself very heavily influenced by the London-type industry (see p 87). Probable Hedingham influences include the simple scheme of decoration with horizontal lines or strips of white clay (Fig 82.55) although Hedingham ware usually employed red as well as white slip. A few white slipped baluster jugs show vertical knife-trimming near the base which gives a vaguely faceted look (Fig 71.1), a common feature of red slipped Hedingham jugs. Colchester-type jug handles were sometimes apparently plugged through the vessel wall as sometimes happens with Hedingham ware and commonly happens with London-type ware (and later Mill Green ware); but it was confined to rod or oval-section handles or it was infrequent or difficult to detect, but was probably a legacy of the London-Hedingham influence.

What early Colchester-type ware did not copy from other regional pottery industries is also worth considering. Except perhaps for the Mill Green polychrome copies at the end of the 13th century (see below) and in the production of louvers, early Colchester-type ware was remarkably unadventurous both in the forms it produced and in the way these were decorated. Green-glazed white slipped jugs and jugs with simple linear decoration in white slip were the staple products, similar to the simplest products of many other medieval pottery industries in southern England. The experimental 'Scarborough'-style schemes of high-relief plastic decoration seen on Hedingham ware were completely avoided. Anthropomorphic decoration does occur on 14th- to 15th-century chafing dishes but not on jugs. Both stamped and combed decoration (never incised through slip) were also extremely rare, and rouletted decoration does not occur at all. Notched strips, possibly copying those on Hedingham ware, occur on three 13th-century jug sherds (Fig 83.67-68). Stabbed and incised decoration, even on jug handles, was fairly rare too. The emphasis, overall, was clearly on simple utilitarian wares, conservative forms that would always find a ready market.

In its most common products early Colchester-type ware is most clearly paralleled by the London-type industry and the Mill Green industry located in central Essex. There are also parallels with medieval Harlow ware (west Essex), but too little is yet known about this last industry to make useful comparisons (Walker 1991d). The similarity between the

Colchester-type and Mill Green industries is obvious. Like Colchester, the Mill Green industry mainly produced a range of white slipped and green glazed jugs and jugs with white slip decoration under a clear or copper-flecked glaze (Pearce *et al* 1982). Although there was definitely some imitation of Mill Green ware at Colchester, it would be incorrect to attribute the appearance of early Colchester-type jugs to wholesale imitation of Mill Green jugs. The most basic elements of early Colchester-type ware (the forms, the white slip, the green glaze, and linear decoration or slip painting) were already in production in the early 13th century, if not in the last few years of the 12th century. These were almost certainly the result of influences from London-type ware, and the same influences almost certainly contributed to the appearance of Mill Green ware. The latter ware is generally dated to c 1270-1350 by its occurrence in London deposits (*ibid*, 292), although recent evidence suggests it may have been in production by c 1250 if not slightly earlier (see above, p 112). On available evidence, Colchester-type ware, starting c 1200, is still the earlier industry. It is not suggested that Colchester-type ware influenced Mill Green ware, but rather that their initial similarity is due to the common influence of London-type ware and the general simplicity of the forms and decorative styles produced.

Apart from the red fabric, white slip and green glaze, Colchester-type and Mill Green ware jugs also commonly have the same inturned rim type and narrow strap handles (Fig 71.1-7). However, the same inturned rim also occurs on medieval greyware (Fabric 20) jugs at Colchester from c 1250/75 (see Fig 65.49-51), and so it was either copied from Mill Green ware or originated by the greywares. At present, however, it is impossible to say which came first. Early Colchester-type jugs with white slip are most commonly baluster-shaped (Fig 71.1-7, 9-10), whereas Mill Green jugs were most commonly conical, pear-shaped or squat (*ibid*, figs 3-4, 5.7 & fig 11). These forms are rare in early Colchester-type ware and the conical form was not produced at all. Combed decoration through white slip, a common Mill Green decoration, is also absent from Colchester-type ware. Thumbled 'ears' on top of the handle and Mill Green-style stabbing down the length of the handle are known on Colchester-type ware (Fig 71.9) but are rare, and the few existing examples probably are copied from Mill Green ware.

The clearest evidence of imitation is the Colchester-type copies of Mill Green polychrome baluster jugs (Figs 73.12 & 82.56-58). These tall elegant baluster forms are the most competent and adventurous products of the Colchester-type industry. The form and polychrome decoration (a Rouen-style chevron and pellets design in red, white and green slip paint) was copied very closely (compare with *ibid*, fig 7, pl I). The same form, with its tall cylindrical neck marked off from the body by a cordon, was probably also copied on some Colchester-type white slipped baluster jugs (eg Fig 71.2). Mill Green polychrome baluster jugs are said to have reached their peak circulation in London c 1290-1306 (*ibid*, 292), and on this basis the Colchester-type copies are assigned to c 1290-1325. However, they were never common.

The simple plastic or thickly slip-painted linear designs on early Colchester-type baluster jugs and some squat jugs may have started as simple strip designs copied from London-type or Hedingham ware or may in some cases have developed out of Rouen-style designs (Fig 82.60).

The most likely source of inspiration for both the Colchester and Mill Green designs, however, was from a range of London-type baluster and squat jugs, current c 1240-90, which employed a variety of simple linear designs in white slip (Pearce *et al* 1985, fig 35.113-15, fig 48, fig 49.166-8). The idea of defining a central zone or frieze of body decoration by placing it between two horizontal lines and also of providing a horizontal line of painting on the rim (Figs 71.5 & 73.13), is most clearly seen on these London jugs; and these became common features of several Essex slipware industries, particularly Mill Green and Colchester-type ware.

Several simple decorative features seen on London-type, Mill Green and Colchester-type jugs became widely circulated throughout East Anglia and southern England. Typical features of Essex/East Anglian redwares from around the 14th century onwards include white slip-painted friezes usually foliage designs, running scrolls or stylised chevron and pellet designs (derived from the Rouen style), slip-painted rims and sometimes a line of white slip down the back of the handle. In the case of Essex, the inspiration behind these long-lived features can probably be traced back to Mill Green and London-type ware (itself influenced by French pottery). For more distant parts of East Anglia (Cambridgeshire for example), it is less easy to argue for direct influence from southern sources. To an extent, these simple schemes were part of a stock or wider tradition of medieval decorative patterns in general circulation, and it would probably be erroneous to link their appearance in every case to the influence of just one or two pottery industries. It is likely, nevertheless, that London-type and Mill Green ware, which were widely circulated in Essex, did play a significant role in spreading these styles throughout the county and that smaller industries such as Colchester-type ware spread these (much adapted) styles to more regional potteries.

There is some evidence that squat jugs in Mill Green ware were commoner in the 14th century (Pearce *et al* 1982, 275; Meddens & Redknap 1992, 22). This trend is also reflected in Colchester-type ware but lags behind Mill Green ware by at least half a century. Squat jugs in Colchester-type ware only seem to have become common in the late 14th century, and they were always slip-decorated in either the 'middle' or 'late' Colchester style and hardly ever covered all over with white slip under a green glaze. Although the Mill Green industry ceased to supply London after c 1350, its products probably continued in local circulation as late as 1400 (Pearce *et al* 1982, 270). Colchester-type jugs and other forms with 'middle' style slip decoration probably date to c 1375-1450, and these continue to reflect the simple geometric schemes (Fig 78.31-33), running scrolls or foliage (Figs 74.18, 75.25-26, 83.61-64, 87.86 & 91.126-127), and debased Rouen-style line and pellet designs (Figs 82.54, 59, 83.62, 64 & 107.245) seen up to a century earlier on Mill Green jugs (Pearce *et al* 1982; Meddens & Redknap 1992; *passim*).

After c 1350, when direct influences from London and Mill Green ceased, Colchester-type ware was left alone to develop its peculiarly regional characteristics which it shared to a large degree with the other 'East Anglian' redware industries, particularly those in Essex (see above p 109) and in adjoining Cambridgeshire. Whatever their source, the sort of scrolling foliage-type designs seen earlier on Mill Green ware now became the legacy of Colchester-type ware and similar East Anglian industries of the late medieval period. Squat jugs with a frieze of scrolls or fleur-de-lis, as Figure 75.25, are closely paralleled at Fen Ditton and Haslingfield in Cambridgeshire (Rackham 1972, pl 50;

Haslam 1984, fig 25.10). A very similar jug also occurs in a context dated to c 1475-1525 at Hadleigh Castle in south Essex (Drewett 1975, fig 20.179). Similar designs also occur in Surrey on 15th-century Cheam white ware (Pearce & Vince 1988, fig 123.556).

Slip dashes on the rims of jugs and jars are the hallmark of late medieval Colchester-type ware. This technique appears c 1400, but is particularly common (in combination with spiky foliage on the body) in the late 15th and early 16th centuries. No other Essex slipware industry exhibits this technique, but identical decoration has been noted on local late medieval redwares from Horsman's Place, Dartford, Kent (unpublished), and a related technique was used on late medieval Sussex Black and White Painted wares (Barton 1979, 122-33). There is no reason, however, to suspect influence from these directions. There are only two other incidences of slip-dashed rims seen by the author outside of the Colchester area. The first of these is a jar, possibly a 15th-/early 16th-century cistern rim, with white slip dashes, found during excavations at Trinity College, Cambridge (information from David Hall). This occurs in the same smooth pale redware fabric as the Cambridge sgraffito vessels found on the same excavation and must therefore be a local product. The second vessel, from Thaxted in north-west Essex, is a large late medieval jar with slip dots (rather than dashes) on the rim. This also occurred with Cambridge sgraffito wares and might also be a Cambridgeshire product (Walker 1996b, fig 23.1).

Other late medieval links with Cambridgeshire and perhaps the east Midlands are suggested by the production of similar (though generally less competent) sgraffito-decorated vessels in Colchester-type ware and also by the production of jars with external lid seating (Figs 91.127-129, 92.130-132), a form characteristic of Cambridgeshire and the east Midlands (see above pp 141-3). The type of large late medieval Colchester-type bowl with near-bifid or 'hammer-headed' rims (Fig 97.169-172) has general parallels with other late medieval bowls such as those in Surrey/Hampshire Coarse Border ware (Pearce & Vince 1988, fig 118.500-507), but these earlier white-ware bowls (c 1340-1440) have not been found in Colchester. Closer parallels exist between the Colchester-type bowls and those from early 16th-century contexts at Denny Abbey, Cambridgeshire (Coppack 1980, group F, c 1500-25, fig 33.63-7 and groups G & H, c 1525-39, fig 36, figs 38-9), and there are strong similarities in both the form and decoration of early 16th-century chafing dishes at Denny and Colchester (*ibid*, figs 34.72, 37.111 & 41.178-81), as well as many other lesser points of similarity.

During the course of this late medieval drift away from southern influences and towards more northerly ones, there were occasional bolts of influence from more distant sources. The matter of Grimston-style (Norfolk) anthropomorphic handles on 14th- to 15th-century Colchester-type chafing dishes has been mentioned previously (see above p 152) but, as no Grimston ware has been identified in Colchester, the suggestion of influence from this industry remains unresolved. The possibility of influences from imported Flemish metal-ware forms, both chafing dishes and lavabos, appears rather more likely. The forms of metal cauldrons were occasionally copied in 14th-/15th-century Colchester-type ware (Fig 89.107-108), and metal jug forms (as well as ceramic copies of these) probably influenced the shape of Colchester-type 'metal copy' baluster jugs in the 15th/16th century and perhaps earlier. There is one convincing attempt to imitate the form of a Saintonge *pégau*

from south-west France (Fig 111.258) but these were never common. The production of possible candlemaker's troughs in the 15th and 16th centuries might also reflect influence from the Low Countries. There are other more general parallels with the forms produced in early post-medieval local wares at Norwich (Jennings 1981, figs 24-9).

In the late 14th and 15th centuries, Colchester potters made clear attempts to copy the forms of biconical and barrel-shaped drinking jugs in Cheam white ware (Fig 80). The unglazed biconical bottles or costrels also found in contexts of this date (Fig 103.216-219) might also reflect influence from this direction or could just be a local reflection of the general fashion for biconical jugs and bottles at this time.

The latest Colchester-type forms, particularly 'tablewares' such as jugs, drinking vessels and perhaps chafing dishes, reflect a wider English fashion for vessels simulating metal forms, imported stoneware drinking vessels, 'Cistercian' ware from the Midlands and Yorkshire, and 'Tudor Green' and Border ware drinking vessels from Surrey and Hampshire. Many of these early to mid 16th-century forms at Colchester are plain and lack slip decoration. They commonly occur in a transitional, finer, more micaceous fabric, presaging that of the post-medieval redwares (Fabric 40) and sharing some of its forms. The larger vessels, bowls and jars remain more regional in character. There are strong similarities between early to mid 16th-century pottery assemblages from Colchester and Braintree in Essex (Huggins 1986) and Denny Abbey in Cambridgeshire (Coppack 1980), thus exhibiting some regional cohesion even in the march towards post-medieval uniformity.

The reasons for the end of the Colchester-type industry (around 1550) are not fully understood. However, the coarseness and heaviness of this essentially late medieval fabric was increasingly anachronistic at a time when most of Essex was now supplied with smoother, lighter post-medieval redwares (Fabric 40). Colchester potters (wherever they were based at this time) seem to have responded for a time by producing a lighter transitional fabric sometimes in typical post-medieval forms (multi-handled drinking vessels, etc), but these could not compete with the lightness and superior glazing of the new post-medieval fabric.



Fig 118 Colchester-type ware: top view of small rounded jug (no 37) with late style slip dashes on rim, c 1475-1525 (rim diameter 93 mm).

By the 16th century, imported Rhenish stoneware drinking vessels were so easily available in Colchester that it was probably pointless for old style Colchester potters to continue with the production of these forms. As the new redware vessels became increasingly available in Colchester's markets, the old style potters probably had little choice but to close down or adapt, and, whichever choice they made, the end of Colchester-type ware was inevitable.

## Distribution

[Fig 119]

Colchester-type ware from the majority of find spots shown in Figure 119 has been identified or checked by the author. Other identifications were made by Carol Cunningham and Helen Walker. It is likely that most of the samples identified, from Essex at least, were actually made in or near Colchester or at nearby Great Horkelesley which may have been the chief production centre for this ware. It is quite possible too that other production sites remain to be discovered in the area. The term 'Colchester-type ware' is preferable to that of 'Colchester ware' as it carries only the broader implication that one is dealing with a sandy (often very sandy) oxidised coarseware, often slipped or slip decorated, and which was made somewhere in north-east Essex. Because of the similarity of so many Essex redware/slipware industries in the medieval period, problems of identification still remain, but it is hoped that the thin-section evidence and neutron activation analysis presented in the report will place the identification of Colchester-type ware on a firmer footing.

Much of the material indicated on Figure 119 is now deposited in Colchester Museum (CM). A full methodical search of the very large reserve collection here would undoubtedly have revealed other find spots of the ware as would a methodical search of other Essex collections. It is clear nevertheless that the circulation of Colchester-type ware was largely confined to north-east Essex. As with the distribution of Hedingham ware (Fig 53), but not so markedly, the westward distribution of Colchester-type ware to Coggeshall, Bocking (near Braintree), and Barnston, High Easter and Great Easton (all near Great Dunmow) probably reflects redistribution from market towns along the medieval Stane Street route to Bishops Stortford (Hertfordshire), while the Chelmsford finds probably travelled along the London Road or arrived via the port of Maldon. The number of coastal find spots, including the ports of Maldon, Tollesbury, Colchester, Harwich, Ipswich and perhaps Covehithe in north Suffolk, are strongly suggestive of coastal distribution, even if some of this represents casual trade conducted by fishermen.

Jugs were the commonest traded form. There are biconical 'Cheam copy' jugs with white slip from Bocking and Wix and a barrel-shaped jug from Ardleigh. Jar forms travelled too, mostly within a 15-mile radius of Colchester. A late 15th-/early 16th-century cistern base and a pipkin handle were found 45 miles further up the coast at Covehithe, north Suffolk (now in Colchester Museum, unaccessioned). There is a 14th-century chafing dish with anthropomorphic handles from the port of Harwich, perhaps one of the more sought-after Colchester items. Strangely it was the bulkiest items — elaborate louvers — that enjoyed some of the widest distribution in Essex. Louvers are known from

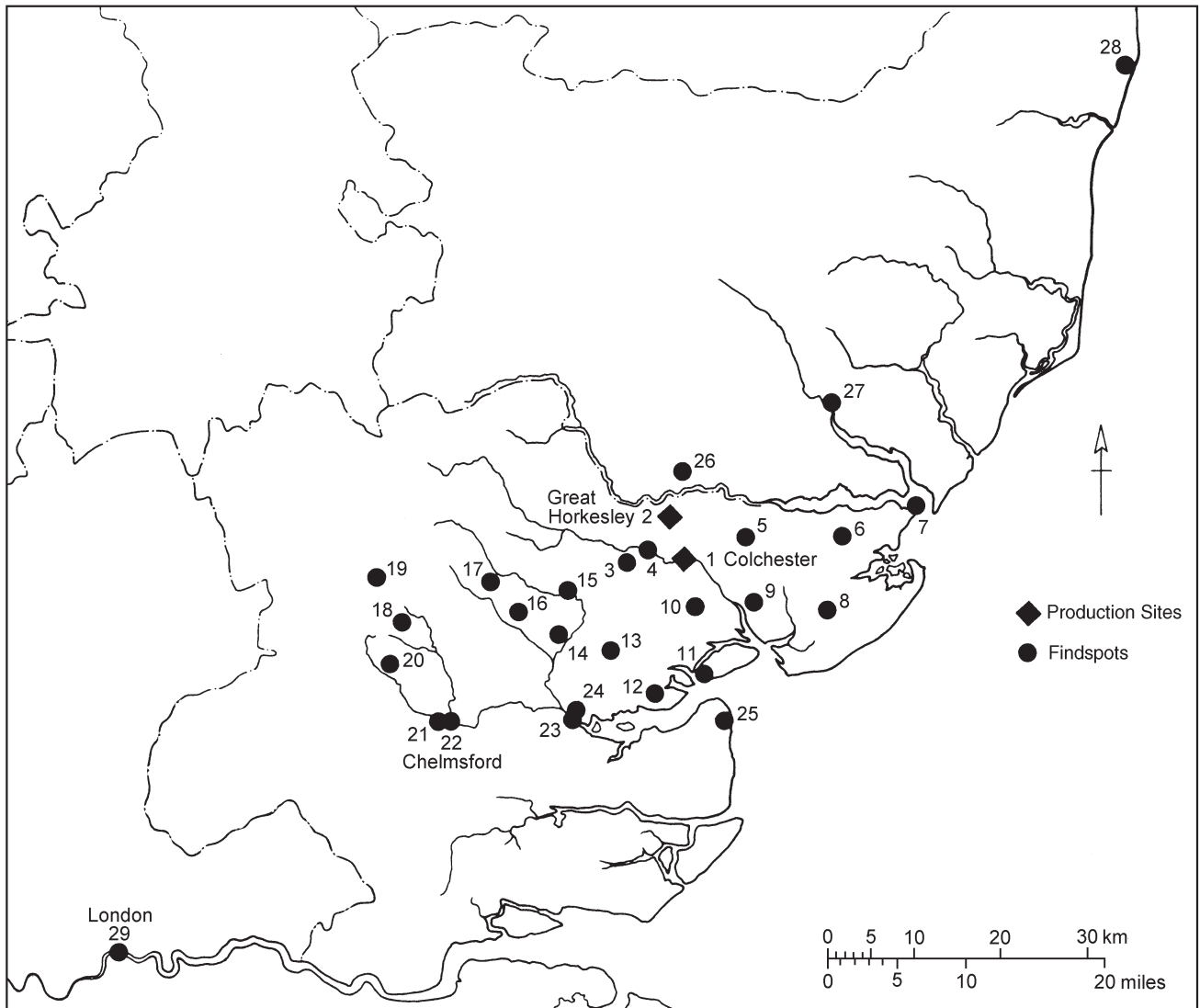

Fig 119 Colchester-type ware: distribution in Essex and adjoining areas.

**Essex**

- 1 Colchester (production site) (Cunningham 1982a).
- 2 Great Horkesley (production site) (Drury & Petchey 1975).
- 3 Aldham (Fig 108.250; CM 2940.14).
- 4 West Bergholt (*CAR 3*, fig 201).
- 5 Ardleigh (Fig 79.41, British Museum; CM 6.61).
- 6 Wix (CM 276.56).
- 7 Harwich (Walker 1990a).
- 8 Weeley (Walker 1994 & pers comm).
- 9 Alresford (CM 8.61).
- 10 Langenhoe (CAT site X566).
- 11 West Mersea (Fig 93.140; CM 758.36).
- 12 Tollesbury (CM 0S.7. 1968).
- 13 Tiptree (*see* p 369; identified JPC).
- 14 Rivenhall (Cunningham & Drury forthcoming).
- 15 Coggeshall (Walker 1988b).
- 16 Cressing Temple (identified JPC).
- 17 Bocking (Fig 79.45; CM 2001.10).
- 18 Barnston (Fig 109.256; CM 76.1971).
- 19 Great Easton (*CAR 3*, fig 201; Dunning 1966a).
- 20 High Easter (Walker 1988a).
- 21 Writtle (Rahtz 1969; identified JPC).
- 22 Chelmsford (*CAR 3*, fig 201).
- 23 Maldon (Maldon Friary; Walker forthcoming (a)).
- 24 Heybridge (*CAR 3*, fig 201).
- 25 Bradwell-on-Sea (CM 130.1977).

**Suffolk**

- 26 Stoke-by-Nayland (churchyard; identified JPC).
- 27 Ipswich (P Blinkhorn, pers comm).
- 28 Covehithe (CM unaccessioned; identified JPC).

**Greater London**

- 29 London (MoLAS; J Pearce; A Vince, pers comm).
  - a 1a The Green, Edmonton, Enfield: TGE 93 [175] spot-date 1480-1550 & [181] spot-date 1400-1550.
  - b West Tenter Street, E1: WTN 83 & 4 [60], spot-date c 1650; [113] spot-date c 1600; [154] spot-date c 1600; [259] spot-date c 1600.
  - c Little Britain, EC2: LBT 86 [918] spot-date c 1270-1350; [1040] spot-date c 1250-1400; [1545] spot-date c 1350-1400.
  - d City of London Boys School, 5-11 Tudor Street, EC4: BOT 86 [1068] spot-date 1400-1550; [991] spot-date c 1330-80.
  - e 9-12 Bridewell Place, EC4: BRI 78 [213] spot-date c 1400-1500.
  - f 21-29 Mansell Street, E1: MAN 82 [107] spot-date c 1500-1600.
  - g 2-5 Minorities, EC3: MRS 86 [1] spot-date c 1400-1550.
  - h 54/56-66 Carter Lane, 1-3 Pilgrim Street, 25-17 Ludgate Hill, EC4: PIC 87 [7] spot-date 1650-1800.
  - i GPO Middle, Newgate Street, EC1: POM 79 [2000] spot-date 1500-1600; [359] spot-date c 1300-50.
  - j River Plate House, 7-11 Finsbury Circus/11-14 South Place, EC2: RIV 87 [114/5] spot-date 1550-1600.
  - k 16 Crosswall/America Square, EC3: ASQ 87 [350] spot-date, residual; [774] spot-date c 1350-1500.
  - l Guildhall Art Gallery, EC2: GAG 87 [157] c 1150-1350; [169] spot-date c 1250-1350; [3568] spot-date c 1250-1400; [45] spot-date c 1150-1250.
  - m Leadenhall Street/98 Fenchurch Street, EC3: LFE 87 [55] spot-date c 1250-1400.
  - n 2-4 St Mary Axe, EC3; SXE 88 [340] spot-date c 1270-1400.
  - o Swan Lane Car Park, 95-103 Upper Thames Street: SWA 81 [2102] dendro-date c 1400; [2083, 2100, 2106, 2112, 2113] coin date c 1430.
  - p Billingsgate Watching Brief: BWB 83 (context and dating unknown).



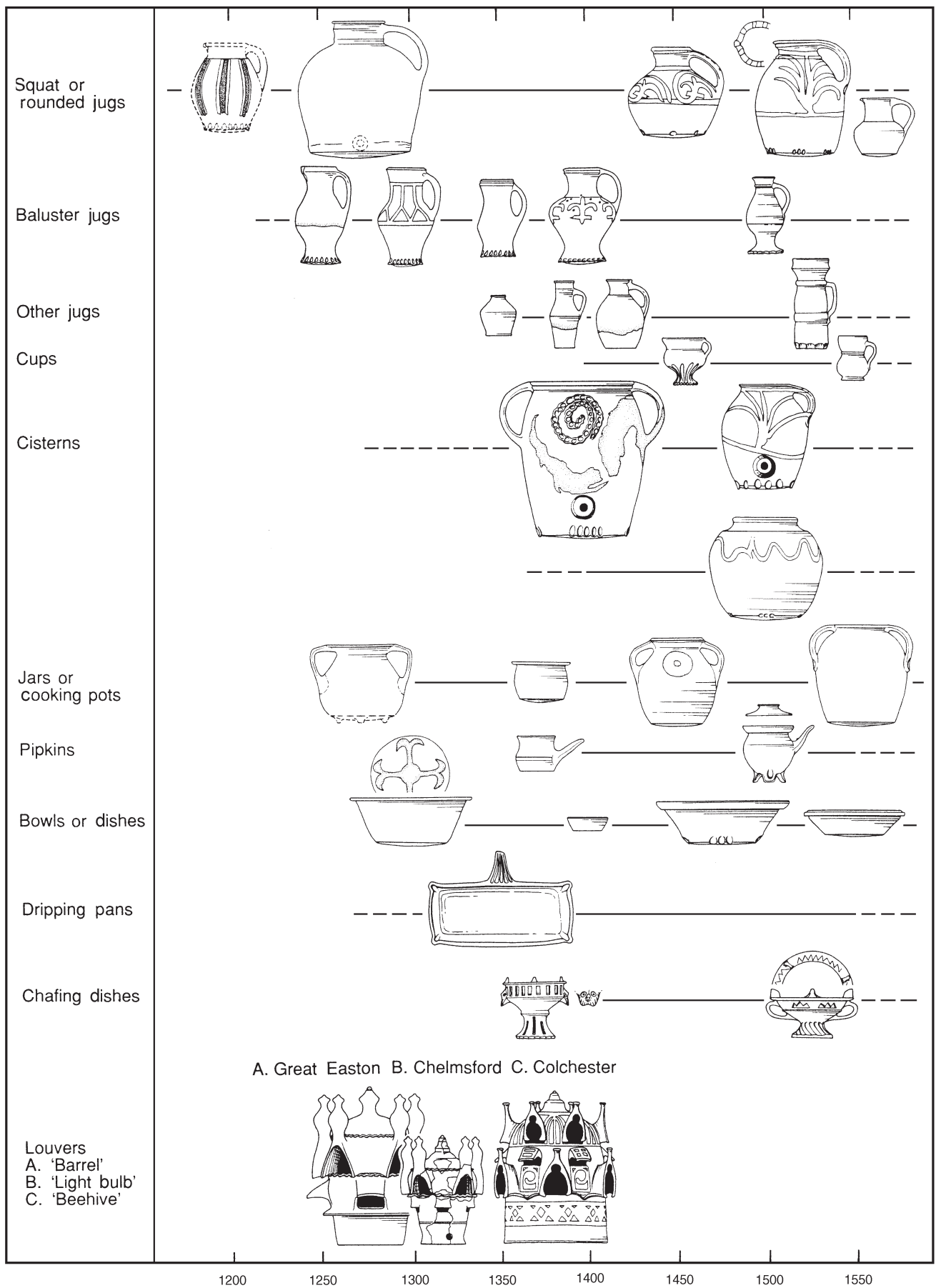

Fig 120 Colchester-type ware: diagram to show the estimated time span of the main forms.

Chelmsford, Heybridge (suggesting coastal transport), West Bergholt and Great Easton, and finials are known from Barnston (near Great Dunmow) and Aldham near Colchester.

The London find spots deserve some attention. Colchester-type ware has been identified from at least sixteen sites, mostly in the City of London (see p 178). However, it remains fairly rare and, as it was identified by a number of people over the years, it is unlikely that all these identifications are correct. The more common slip-painted 'Colchester-type' ware at London (COLS) could be confused with Mill Green ware, particularly the late types, and with Cheam redware (J Pearce, pers comm). Thin-sections have been made of some of the London finds (including those from Swan Lane), and some of these compare well with true Colchester-type samples donated to the London (MoLAS) reference collection. The only London finds of Colchester-type ware examined by the author are those from Swan Lane from contexts dated by dendrochronology and coins to between c 1400 and c 1430 (Alan Vince, pers comm). The 'Colchester-type' sherds include a cooking pot rim, a frilled cistern bung-hole, a jug rim, handle and base, and a slip-painted jug or jar sherd. Most of these are probably sandy Essex redware (Fabric 21), but not necessarily from the Colchester area. The frilled or faceted cistern bung-hole is more convincing, however, and the slip-painted sherd is almost certainly a Colchester-type product. The latter has a linear pattern in white slip (possibly chevrons, as Fig 83.63) under a clear greenish glaze. It is reasonably certain therefore that some Colchester-type ware reached London even if only a fraction of the sherds identified as Colchester-type are actually from the Colchester area.

The presence of Colchester-type ware at London, albeit a very minor presence, has interesting implications. No Colchester-type ware has yet been identified in southern Essex. It probably does occur but is rare and awaits recognition. This gap in the distribution suggests that the London finds arrived by sea. The presence, furthermore, of a few sherds of Colchester-type ware at Billingsgate, a quay with traditional links with East Anglia (Alan Vince, pers comm), suggests that pottery from the Colchester area may have found its way to London as a consequence of coastal trade between these regions, though probably as ship accessories or containers rather than a saleable commodity in itself.

## Conclusion

Colchester-type ware was never a major pottery industry in the same league as, for example, London-type ware, Mill Green ware and the Surrey white wares. Nevertheless, it was an important local industry and probably the main supplier of glazed and slip-decorated wares to a large part of north-east Essex and perhaps part of Suffolk. Originality and innovation were not marked features of the Colchester-type industry and, except perhaps in some minor details, most of its features can be paralleled, at least generally, in many other pottery industries of the south-east. It is a classic example of the late medieval tradition of slip-decorated pottery known as East Anglian redwares which, although never confined to East Anglia in any strict sense (and apparently uncommon in Norfolk), does seem to be a real East Anglian phenomenon. Colchester-type ware is the only industry within this tradition to have been studied in any depth, from its emergence in the late 12th or early 13th century to its extinction in the mid 16th century. The story of

Colchester-type ware should therefore have a wider relevance to the understanding of other Essex and East Anglian pottery industries operating within this tradition.

While not quite unique, Colchester potters can at least be credited with developing and extending the range of traditional slipware designs. They are to be admired too for their versatility which allowed the production of a very wide range of vessel forms, everything from jugs and cooking pots to inkwells, candlemaker's troughs and distilling equipment. The production of elaborate roof furniture, highly decorated louvers and finials must be regarded as a Colchester speciality which found a ready market throughout the northern half of Essex and possibly beyond.

Early Colchester ware began life primarily as a tableware industry largely in the form of glazed jugs, strongly influenced at first by more widely circulated quality wares produced further south at London and later at Mill Green in central Essex. Colchester jugs would have provided humbler households with a cheaper local alternative either to the quality wares from the south or to costly metal vessels. External factors (eg the local greyware industry) at first restricted the sort of vessels available in Colchester-type ware and also the amount in circulation. In contrast, late Colchester-type ware was mass-produced largely in the form of robust unglazed kitchenwares, mainly brewing jars, storage jars, large bowls and a wide variety of more specialised forms. The industry still reproduced some of the basic decorative schemes inherited from its earlier southern influences, but these were now debased almost beyond recognition. The Rouen style, for example, copied from London-type ware in the early 13th century, ended up in the 16th century as a collection of slip-painted strokes and dots thrown together in any order that took the potter's fancy. By now Colchester-type ware had assumed a deeply provincial East Anglian character expressed in its own idiosyncratic range of shapes and decoration.

The late industry had few of its earlier pretensions. The increasing availability of metal vessels and imported stonewares forced it to concentrate on the production of unsophisticated, serviceable household utensils. These were nevertheless quite well made and well adapted to their functions, and, with their vigorous provincial slip decoration, they were no doubt attractive enough to their users.

## Mill Green ware (Fabric 35)

[Figs 121-22]  
Weight: 3.435 kg  
Number of sherds: 317  
EVEs: 1.45

## Fabric

The fabric is relatively fine, hard and usually brick-red with a grey core. A definitive study of Mill Green ware has been published (Pearce *et al* 1982). A full description of the fabric and thin-sectioning is given there (pp 277-9). The Colchester examples conform completely. Only fine ware has so far been recognised in Colchester.

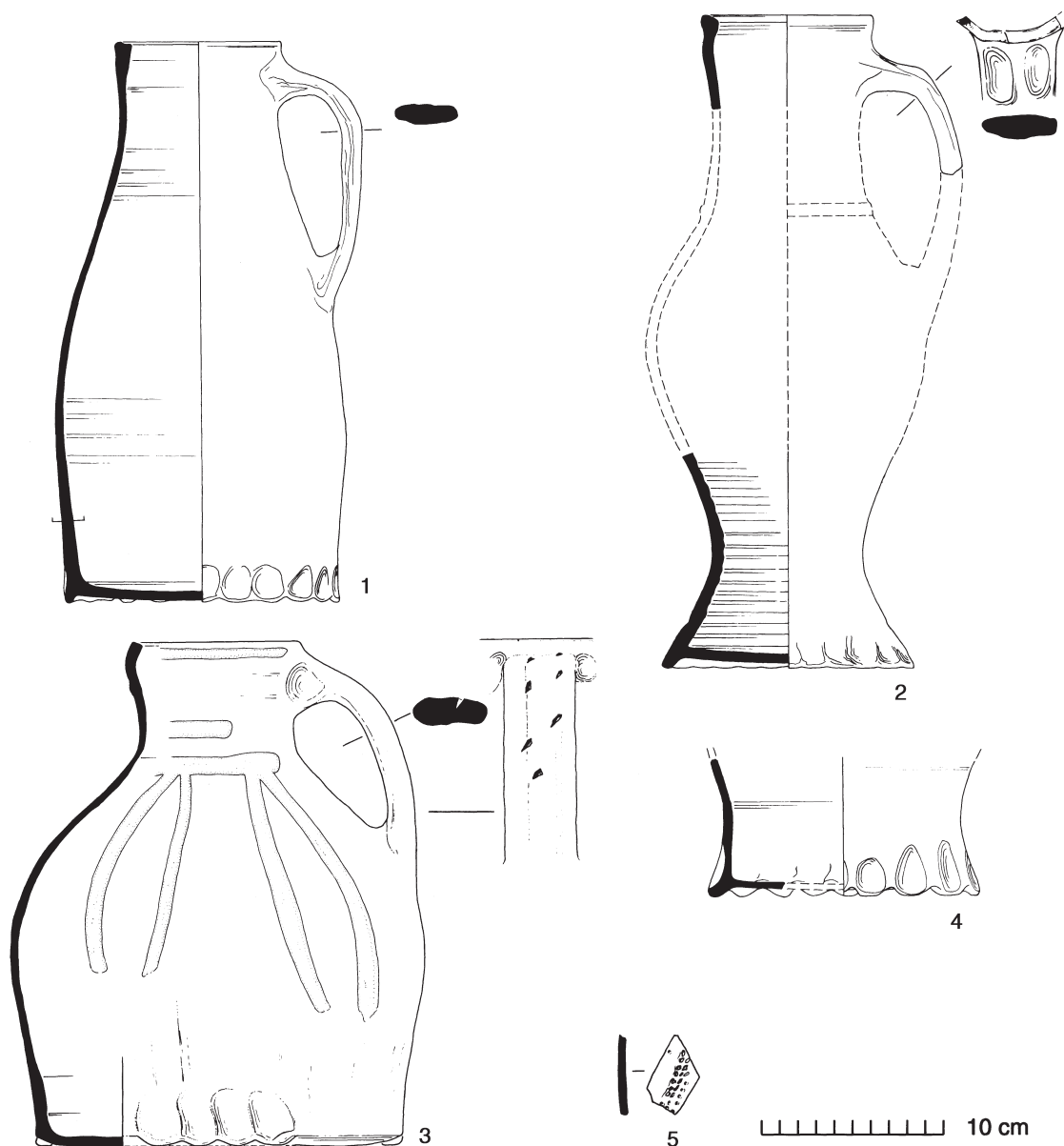

Fig 121 Mill Green ware: conical jug (no 1); baluster jug (no 2); squat jug (no 3); pear-shaped jug (no 4); sherd with comb-stabbed decoration (no 5). 1:4.

**Form and decoration**

All four basic jug types are represented at Colchester:

**1. Pear-shaped jugs (Fig 121.1)**

One example only, with a continuously thumbbed base and all over white slip under a mottled green glaze. Undecorated, but two very slight ears are visible on top of the handle. The slip ends 30 mm above the base.

**2. Baluster jugs (Fig 121.2)**

Fragments from one example only, as Figure 121.1 above but with well-defined 'ears'.

**3. Squat jugs (Fig 121.3)**

One example, with slip-painted decoration (a thick paste probably applied with the finger) and a partial plain glaze with green flecks. Stabbed handle and base thumbbed in groups of four.

#### 4. Rounded jugs (Fig 121.4)

One example. Fragment from continuously thumbbed base. White slip ending above base, clear glaze splashes.

#### Decoration

The most common type of decoration is vertical bands combed through a thick slip (not illustrated). One example has diagonal intersecting bands, probably from a lattice decoration. The next most common is slip-painted decoration, normally associated with the squat jugs. The only other type present is stabbing in bands resembling roller-stamping, probably done with a three-pronged comb (Fig 121.5). This type of decoration has not previously been noted.

#### Dating

[Fig 122]

The London waterfront sequence has for the first time provided a reliable framework for the dating of Mill Green ware, although the occurrence of the ware in London may not be typical of other areas. There the appearance of Mill Green has been placed between c 1240 and 1270 (probably closer to c 1270), and it was probably residual by the second half of the 14th century (*ibid*, 272, 275). More recent opinion suggests an earlier starting date for the industry, probably in the first half of the 13th century (Meddens & Redknapp 1992, 22), and perhaps by c 1250 the ware was in general circulation.

The Colchester evidence only confirms our knowledge of the ware and its possible development derived from the London sequences, other than the existence of stabbed as well as combed decoration. It is found associated with a coin of Alexander III lost c 1280-1350 (MID EL378; Period 4.1), and with one of Henry III of c 1250-1279 (CPS L48; Period 3/4.1: *CAR* 4, 67, 66), although these do not necessarily date the deposition of the pottery.

Only one slipped sherd of Mill Green ware occurs in Period 3.1 contexts. In Period 3.2 (c 1250/75-1400), the ware formed 2.6% of the assemblage but 4.5% of the Period 3/4.1 assemblage (c 1200-1500), although most of this figure is provided by only two or three jugs.

#### Discussion

In Pearce *et al* 1982, Mill Green is shown as absent from Colchester (*ibid*, fig 2). While this is obviously no longer correct, it does show that Colchester lies on the extreme north-east limit of its distribution. Given that it comprised 10-20% of the London assemblage during its currency (*ibid*, 270), its presence in Colchester is comparably minor though relatively still fairly significant compared with London-type and Hedingham ware.

The irregular occurrence of the ware around Colchester is in itself unusual. While the Cups Hotel site (CPS) and other High Street sites have yielded relatively large quantities, at the Long Wyre Street site (COC), which produced one of the best medieval sequences in the town, Mill Green was entirely absent although it was here that Mill Green polychrome copies in Colchester-type were found (*see above* p 115).

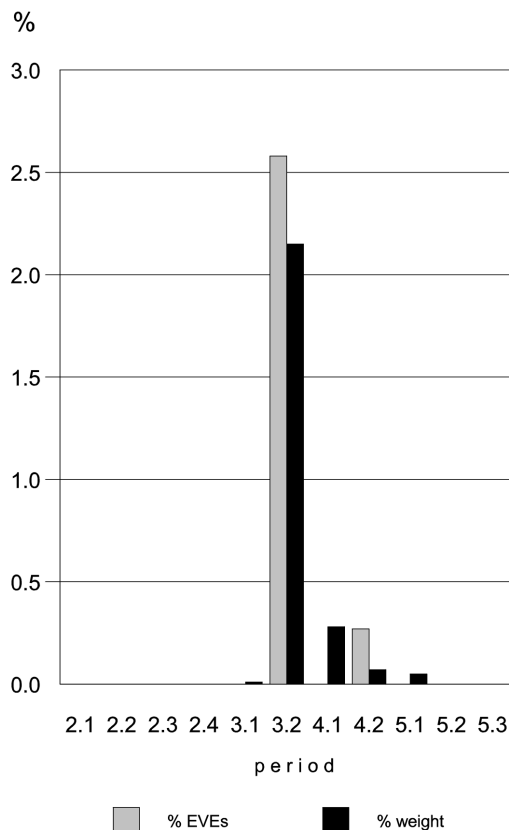

Fig 122 Mill Green ware: bar chart showing percentages in stratified contexts (ceramic periods).

Mill Green ware takes its name from its type-site near Ingatestone (Essex), where evidence of kilns has been found (*ibid*, 268). Only five miles north-east at Chelmsford, both the fine ware and the coarseware are ubiquitous (Carol Cunningham, pers comm). Further north, it is hardly surprising that no Mill Green coarseware has been recognised at Colchester where a healthy local coarse-ware industry existed by this time. Except that they were heavier and in a coarser fabric, jugs in Colchester-type ware could look remarkably similar to Mill Green jugs at this time, and the difference may not have mattered to the average medieval consumer. Whether by direct imitation, as in the case of the polychrome wares, or by parallel development, the visual similarities between Colchester-type ware and Mill Green ware undoubtedly prevented the latter from establishing a greater presence in Colchester than it already had.

#### Kingston-type ware (Fabric 23D)

Weight: 0.090 kg  
Number of sherds: 17

This was produced at workshops along the south bank of the Thames from Kingston upon Thames to Southwark. Production started in the first half of the 13th century,

reached its peak of circulation in London in the later part of the century, and came to an end by the start of the 15th century, if not slightly before that (Pearce & Vince 1988, 16, fig 9). The fabric is generally hard, buff and sandy with abundant rounded and sub-angular quartz grains being dominant, often iron-stained and generally under 0.5 mm (*ibid*, 9). A minimum of thirteen vessels is represented by an unimpressive collection of small sherds (not illustrated), all of which were found in isolation and must therefore be largely residual. Most of these probably come from jugs, mostly green glazed externally, although two sherds with glaze on both sides may come from a different form, and one thin strap-handle fragment probably comes from a 'Tudor Green' vessel. A single small rim sherd comes from a jug with an internally beaded, thickened, flat-topped rim (1.81 EF9; as *ibid*, fig 64.70) and perhaps therefore from a conical jug. The most interesting piece is a body sherd from a Kingston-type ware polychrome jug of the second half of the 13th century. This has a buff fabric with an applied ring and dot stamp in a finer white clay with an external clear brownish glaze and a green-painted applied strip (as *ibid*, fig 10 & figs 21-3). It was residual in its context (LWC BF46) which contained a coin of 1335-41 probably deposited *c* 1400 (*CAR* 4, 65). Another sherd (1.81 B3) appears to have a fragmentary 'wheatear' stamp and perhaps a crossed circle stamp impressed directly on to the body. Another has a plain applied pellet of body clay (BUC E826). Two sherds have a smeared red-brown clay stripe (LWC KF64 & LWC KF22).

In addition to this meagre collection, there are a number of substantially complete Surrey white-ware vessels in Colchester Museum. Most of these are unaccessioned and unprovenanced but it is more than likely that they were found in Colchester during 19th-century building operations. Among the forms tentatively identified as Kingston-type are the following: a large globular jug with a pinkish fabric (CM25.4.38; collared/thickened flat-topped rim similar to *ibid*, fig 75.132); the lower part of a rounded flat-based jug with deep external grooving and a pouring-lip (discovered under reading room behind town hall, 1893; similar to *ibid*, fig 72.116 but without stamps); a small rounded jug with internal green glaze (Acton Collection; as *ibid*, figs 79-81); lower part of a conical jug with paired groups of pulled feet and trilobe handle (form as *ibid*, fig 64.72); a small rounded jug with 'wheatear' stamps, lacking rim (cf *ibid*, fig 72.114); and two small plain bowls (as *ibid*, fig 98.350 & 363).

### Coarse Border ware (Fabric 23F)

Weight: 0.125 kg  
Number of sherds: 9

As its name implies, this ware was produced along the border area of north-east Hampshire and west Surrey. Its first appearance in London in the mid 13th century is synchronous with that of Kingston-type ware although the quantities involved were much smaller. By the late 14th and 15th centuries, however, it was the commonest type of pottery used in the city, but by the start of the 16th century production appears to have ceased (Pearce & Vince 1988,

84, 91, fig 9). Coarse Border ware has a hard, typically buff fabric with abundant ill-sorted, rounded and sub-angular quartz generally under 1 mm. These are often iron-stained, often along the cracks. Inclusions are generally coarser than in Kingston-type ware (*ibid*, 9).

A minimum of four vessels are represented (not illustrated). Three of these are basal fragments: a flat ?jug base with a pale greenish-yellow glaze all over the underside with a dribble down the side (LWC A19; as *ibid*, fig 106.415; a sagging ?jar base with mottled green glaze on both sides (LWC G279); and the base of a tripod cauldron, flat or very slightly sagging with part of an applied tripod foot decorated externally with three incised vertical grooves, green glazed externally with splashes internally and under the base (LWC G247; as *ibid*, figs 116.487 & 117.490). A narrow, furrowed strap handle occurs in the same context as the latter. Four sherds come either from the shoulder of a large globular jug or a cistern with a bib of glossy dark brownish-green glaze (LWC L53 & LWC L70). All of the pieces described above were residual in their contexts.

### Cheam white ware (Fabric 23E)

[Fig 123]  
Weight: 0.435 kg  
Number of sherds: 15  
EVEs: 0.34

Cheam ware was produced at the Cheam kilns in Surrey although it could conceivably have been produced at other sites. It first appears in London contexts *c* 1360 and became common in the 15th century. It is thought to have continued in production into the early 16th century (Pearce & Vince 1988, 17, 91, fig 9). The fabric is similar to Kingston-type ware but the inclusions are finer: quartz grains are generally under 0.25 mm and the matrix is also slightly finer (*ibid*, 10).

At least ten vessels are represented. The only certain form present is the small barrel-shaped drinking jug (Fig 123.1-3; cf *ibid*, fig 121). Those illustrated are unglazed except for some tiny green splashes (the fronts of the jugs, however, were not recovered). Three jugs display stabbing arrangements typical of the method used to attach the handle to the body and which is virtually unique to Cheam ware (Fig 123.1-2; *ibid*, 73-4). Figure 123.1 is unusual in that it has been over-fired to a near-stoneware hardness.

Figure 123.4 may well come from the base of a Cheam biconical jug. This is suggested by its narrowness, straight sides and its early context (*ibid*, fig 122.543-51). It is unglazed except for some greenish splashes on the underside. Biconical Cheam jugs are typical of the late 14th century while barrel-shaped jugs made their appearance in the early 15th century (*ibid*, 86, fig 47). The earliest Colchester context to produce Cheam ware was associated with the refurbishment of the town wall *c* 1382-1421 (Stratified Group 9), which produced the jug base described above (Fig 123.4). A relatively large unglazed body sherd from a large jug or a cooking pot was found in Stratified Group 11 (*c* 1425-75). Figure 123.3 came from a pit with

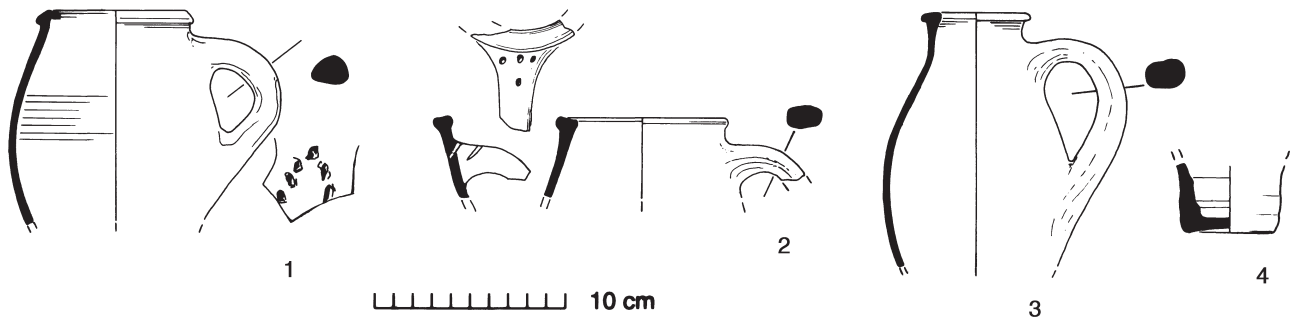

Fig 123 Cheam white ware: barrel-shaped jugs (nos 1-3; no 1 with internal detail of stabbing to attach handle); biconical jug base (no 4). 1:4.

late 15th-/early 16th-century Raeren stoneware mugs, a *Jacobakanne*, a Siegburg jug and Colchester-type ware forms of a similar date. Two other barrel-shaped jugs (including Fig 123.1) were found with very similar assemblages.

There are in addition three Cheam vessels in Colchester Museum: two slender biconical jugs (?Acton Collection no 115 & unaccessioned); and a small barrel-shaped jug (unaccessioned).

**'Tudor Green' ware (Fabric 41)**

[Fig 124]  
 Weight: 0.600 kg  
 Number of sherds: 99  
 EVEs: 0.63

It is now recognised that 'Tudor Green' ware was not a separate pottery industry but was a minor component of all three Surrey white-ware industries (Pearce & Vince 1988). 'Tudor Green'-style thin-walled green-glazed cups in a virtually untempered white fabric might have been made as early as the late 13th to early 14th century, but in London contexts they are uncommon until the late 14th century. By the early 16th century, when the production of coarse white wares in Surrey was dying out, production of fine 'Tudor Green' ware drinking vessels was at its peak (*ibid*, 17, 88-9).

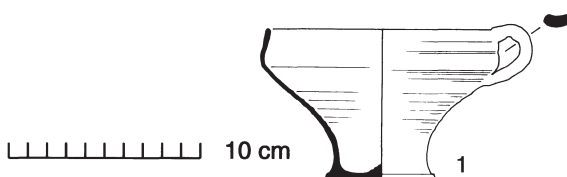

Fig 124 'Tudor Green' ware: pedestal-footed cup (no 1). 1:4.

Being thin-walled and delicate, 'Tudor Green' ware breaks easily into small sherds which can easily be confused with 16th- and 17th-century Surrey/Hampshire Border ware. Much of the Colchester collection occurs in this state. A minimum of around 30 vessels is represented. The commonest form encountered is a pedestal-footed drinking cup of which Figure 124.1 is an almost complete example. There is an identical complete example in Colchester Museum (CM 116.1971). Both of these are covered internally with a mottled green glaze which extends outside as far as the carination. A few sherds (not illustrated) come from similar cups with flaring everted rims and there is one rim sherd from a cup with pinched lobes (SPT L1). One small rim sherd, perhaps from a cup, is rilled externally and has incised vertical lines (not illustrated: 1.81 HL3). A few sherds come from globular vessels such as small jars or jugs and some base sherds are probably also from jugs. There is at least one whole 'Tudor Green' ware ovoid-bodied jug in Colchester Museum as well as a smaller globular jug (unaccessioned; as Brears 1971, 24, types 1 & 2 respectively).

As one would expect, the earliest examples of 'Tudor Green' ware from Colchester date no earlier than the late 15th or early 16th century. Figure 124.1 was found with Raeren stoneware mugs of this date, and a few sherds also occur in Stratified Group 12 (c 1475-1525).

**Cistercian ware (Fabric 40C)**

[Fig 125]  
 Weight: 0.090 kg  
 Number of sherds: 15  
 EVEs: 0.75

This well-known ware has a smooth red fabric covered in a glossy black glaze, and is sometimes decorated with stamped pads and blobs of white clay. It was produced in the north Midlands, and particularly in Yorkshire, from around the end of the 15th century and throughout much of the following century (Brears 1971, 18-23).

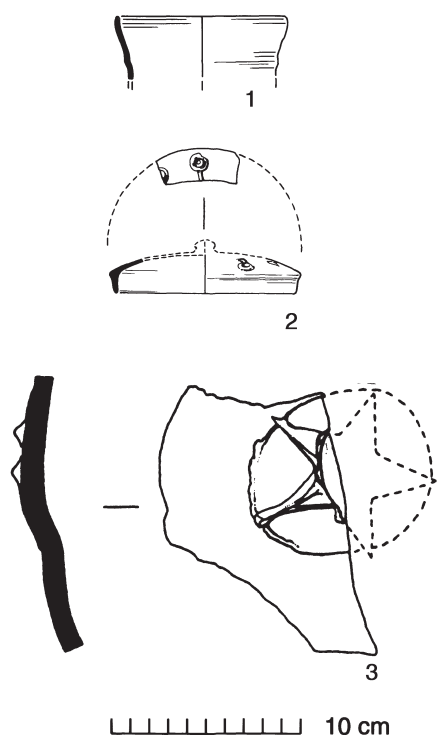

Fig 125 Cistercian ware: cup (no 1); lid with white pipeclay decoration (no 2); sherd with stamped pad (no 3). 1:4; stamp detail at 1:1.

Cistercian ware has a very minor presence in Colchester. The only two forms found so far are plain, flaring-walled cups (Fig 125.1; Stratified Group 14, c 1525) and a lid with applied decoration in white clay (Fig 125.2). There is also a sherd with an applied white clay pad stamped with a star design (Fig 125.3).

**Miscellaneous unidentified medieval and post-medieval wares, probably English (Fabric 98)**

[Fig 126]  
 Weight: 1.190 kg  
 Number of sherds: 69  
 EVEs: 2.29

This category consists of coarsewares and fine wares, mostly in the form of small body sherds, for which close parallels could not be found either within Essex or beyond. It would serve little purpose to describe each individual sherd. However, a small number of fabrics are sufficiently distinctive to warrant classification and discussion, while a few other vessels are illustrated for their intrinsic interest. The distinctive fabrics are treated under sub-headings (eg Fabric 98s and 98w) and are quantified separately from the main body of unrecognised fabrics (Fabric 98).

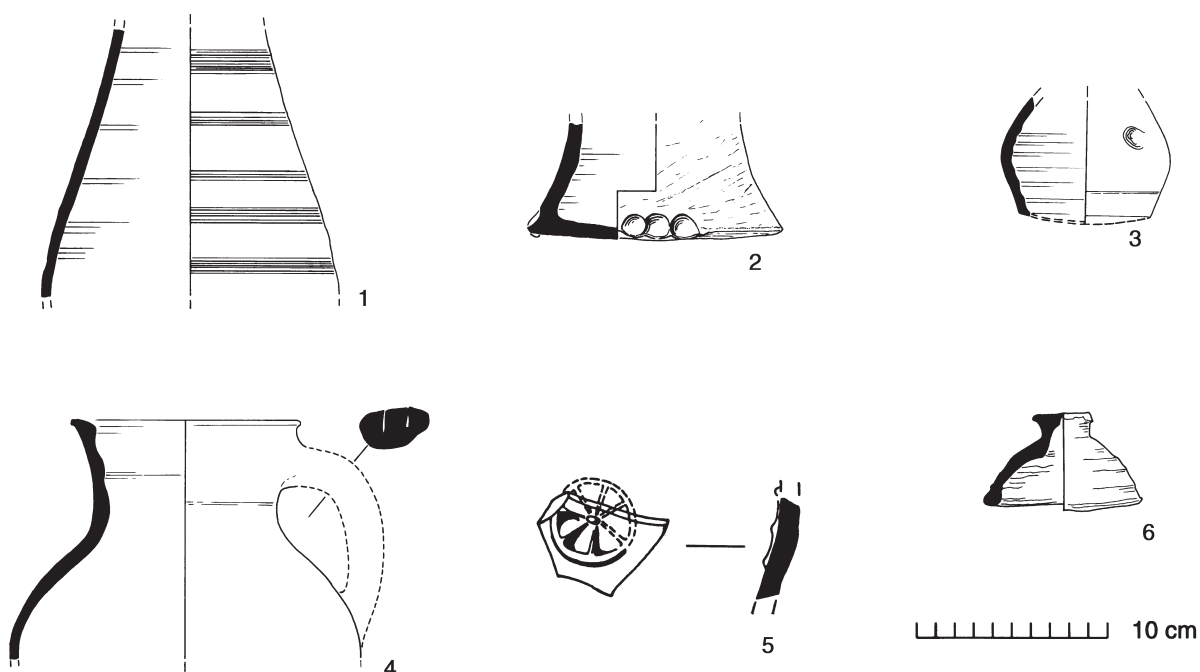

Fig 126 Miscellaneous unidentified medieval English wares: Fabric 98W 'Long Wyre Street' ware (nos 1-3); Fabric 98S non-local slip-painted ware (no 4); Fabric 98 stamped jug sherd (no 5); Fabric 98 lid (no 6). 1:4; stamp detail at 1:1.

### Fabric 98: miscellaneous

Figure 126.5. Dense finely sandy reduced grey fabric. The applied stamp has dull oxidised margins. Covered externally with reduced green glaze. Applied stamped pad with cartwheel design, concave in cross-section. Probably 13th century. Not London-type ware (Alan Vince, pers comm). Possibly Colchester-type.

Figure 126.6. This is a dull red, sandy, somewhat silty and slightly micaceous unglazed fabric with fairly smooth chocolate-brown surfaces. It is something akin to Fabric 21 (ie red and sandy), and it may transpire that the vessel is simply an unusual form in a late medieval/post-medieval transitional Fabric 21 produced somewhere in Essex. The vessel (GBS, unstratified) is somewhat underfired and weakly oxidised compared to the normal range of this fabric.

The form is a small, complete, bell-shaped lid, perhaps intended for a jug. There are some fine white calcareous inclusions in the fabric and the whole vessel has been covered with a thick, dark brown wash or slurry. It is warped, and the knob has been accidentally perforated during manufacture.

Bell-shaped lids are known from other parts of the country. There is a very similar example from a late 14th- to early 15th-century kiln at Olney Hyde, Buckinghamshire (Mynard 1984, fig 12.101). Similar lids, also pierced, were produced at a Carolingian kiln at Meudon in south-west Brittany (Hodges 1981, fig 7,6,13), but this highly micaceous Breton ware is quite unlike that of the lid shown here and the resemblance is probably coincidental (GBS, unstratified).

### 'Long Wyre Street' ware (Fabric 98W)

Weight: 0.435 kg  
Number of sherds: 13

This has a hard, pale to medium grey, sandy fabric with browner margins. It contains abundant coarse sub-rounded quartz, some of it tinted red or brown. It also has rare red and black iron oxide. Vessels are covered on the outside with a dull, pitted, brownish-green reduced lead glaze. Three vessels in this fabric were excavated. Figure 126.1-2 were found in the same context on Long Wyre Street but appear to come from two separate baluster jugs. The jug base Figure 126.2 is unglazed, except for external splashes and a pool of glaze on the underside which retains a clear stacking impression of another jug with a rim diameter of about 110 mm and probably with a pouring-lip. This is also informative in showing that jugs in this ware were fired

upside-down. Both vessels come from a context of c 1225-75 (Stratified Group 7).

The only other vessel known in this fabric (Fig 126.3, Period 3.1) resembles a moneybox in form, but could have been a small oil jar or similar vessel. The base, however, is clearly sooted. There is a bib of greenish reduced glaze which partly covers a large spalled area on the shoulder, and there are glaze splashes on the underside.

The only external parallel for this fabric is a sherd from Chelmsford Dominican Priory. Even there it is a rare fabric and is poorly dated by comparison with Colchester. One can say only that this fabric appears to be rare in central and north-east Essex and that it does not closely resemble any known wares in London or Kent (Alan Vince, Nigel Macpherson-Grant, pers comm). At best one can suggest that this fabric is the product of some minor industry perhaps located in Essex or Suffolk.

### Non-local slip-painted ware (Fabric 98S)

Weight: 0.170 kg  
Number of sherds: 5  
EVEs: 0.08

A single vessel occurs in this ware (Fig 126.4). This has creamy pale brown or fawn surfaces with a pale grey core. It has a porous biscuit-like texture with fine-medium inclusions of rounded and sub-rounded quartz often with a pink tint. There are moderate fine-medium inclusions of black iron oxide, abundant fine mica and rare chalk or limestone inclusions. The vessel is a round-bodied jug of fairly crude manufacture with external knife-trimming below the maximum girth and several deep short slashes down the handle. A separate sherd, almost certainly from the same vessel, has a horizontal painted band in thin white slip. There are external splashes of clear greenish glaze possibly with a few copper flecks, and it appears the vessel was fired upside-down.

No close parallel has yet been found for this jug in southern or eastern England, although it has been examined by several regional specialists. Superficially it resembles many late medieval local wares around the country but nothing specific. An East Anglian source is probably most likely. A jug in a remarkably similar fabric, thought to be English, is known from a 13th-century context at Cork in southern Ireland, although the latter is unslipped and has a strap handle with thumbled edges (Claire McCutcheon, pers comm). The Colchester jug is from a context of c 1475-1525 (Stratified Group 12).



## Chapter 5. English wares: post-medieval (c 1550-1750)

### Guy's-type ware (Fabric 55)

[Fig 127]  
Weight: 2.400 kg  
Sherds: 30  
EVEs: 0.59

A minimum number of eight vessels have been recognised from the 1971-85 excavations, though several more have also been recognised among unprocessed material from the 1986-7 Angel Yard site. The material discussed here has a hard sandy fabric, composed predominantly of fairly fine to fairly coarse quartz sand with a scatter of coarser sub-rounded grains, moderate coarse red iron oxide (appearing grey-black in reduced zones), abundant fine mica, some voids and rare calcareous specks. The firing is quite distinctive: in general the margins and surface form a

thin brownish-orange oxidised skin while the core is a sandwich of light and darker grey tones, sometimes clearly distinct from the oxidised margins and at other times becoming brownish and merging with them. However, one vessel (Fig 127.2) has a completely oxidised orange fabric with a slightly darker core where thick. All examples illustrated here have a thick internal covering of white slip. On Figure 127.1 the whole interior and the rim lip is slipped and there are a few external spots of slip; the interior was then covered with a clear lead glaze. On the other two vessels (Fig 127.2-3), the slip only covers the lower half of the interior with a few splashes occurring on the outside. The interior has then been covered with an irregular green-flecked glossy glaze. In all these examples it is quite clear that the slip was poured in liquid form into the bowl and swilled around to extend the coverage; the vessels were then allowed to dry in an upside-down position causing dribbles of slip to run down and drip off the rim (alternatively

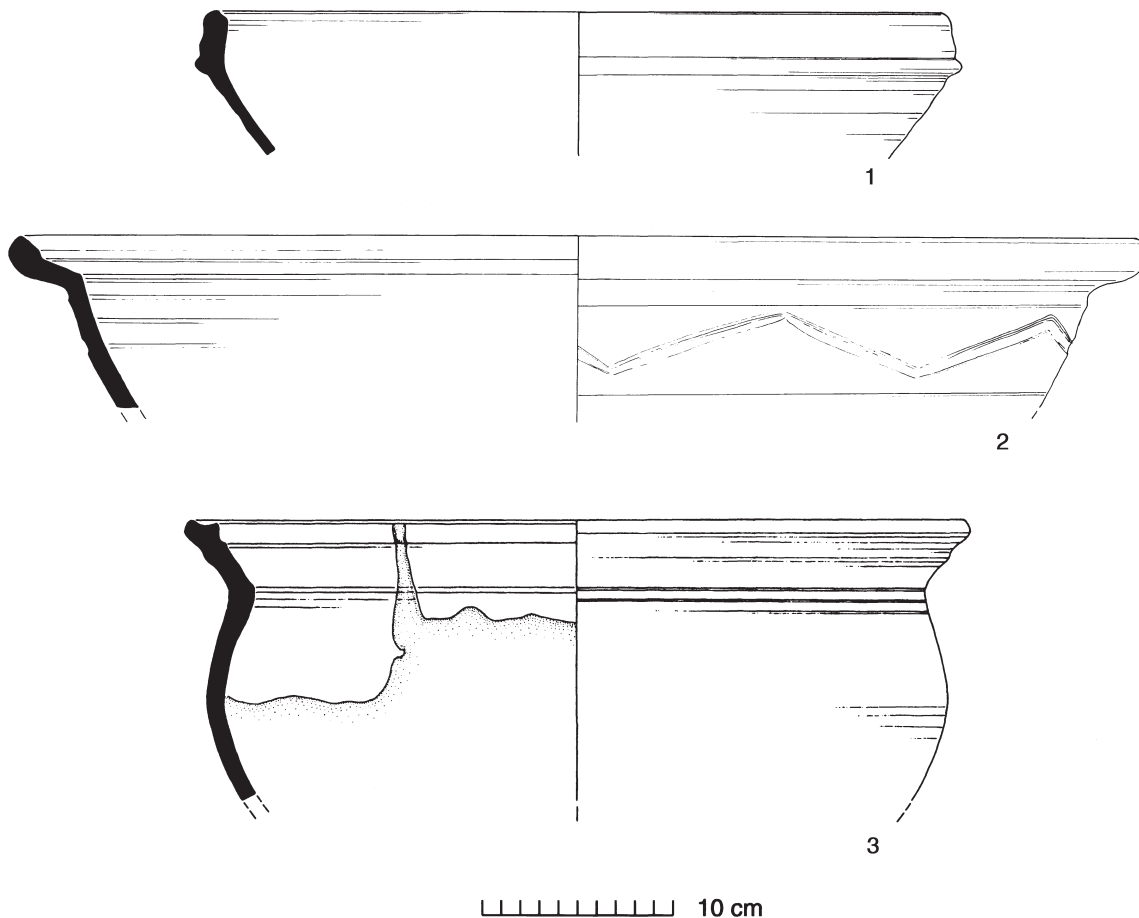

Fig 127 Guy's-type ware: bowls (nos 1-2); ?cauldron (no 3). 1:4.

the vessel was turned upside-down to pour out the excess slip while the covering dried more or less instantly). This is one of the distinctive characteristics of Guy's ware as observed at its type-site at Guy's Hospital in Southwark, London (Dawson 1979, fiche p 228). The fabric has a superficial resemblance to early Colchester-type ware, but the forms and method of slip application are quite different.

Dawson (1979) pointed out the strong typological links between Guy's ware and Dutch redware forms but concluded that their differences (particularly the slip technique) argued for a London rather than a Continental origin.

There is at present a degree of confusion over the precise definition of Guy's ware and whether it represents an 'industry' or a more widely-based 'tradition' of late medieval/post-medieval Dutch-style pottery produced in the London area. The fabric defined as Guy's ware by Dawson is a clear glazed, white-slipped redware (sometimes with sgraffito decoration) which first occurs in contexts dated to c 1480-1520 (*ibid*, 44, 58-60). This definition was not applied to the green-glazed slipwares recovered from the site nor to the unslipped green-glazed redwares or any other redwares, even though the fabric and sometimes the forms appear very similar and most appear to reflect Dutch influence (*ibid*, figs 5-11). Dawson's suggestion, that the green-glazed slipware forms (mainly cauldrons, pipkins and slip-bibbed jugs) were later than the clear glazed slipwares, seems to be borne out by the evidence from Colchester (*ibid*, fiche p 230; see below).

Wasters of Guy's-type ware are known from a number of production sites around London: at Lambeth, for example (*ibid*, fiche p 228-30), and particularly from a large dump of kiln material at Woolwich (Pryor & Blockley 1978, 44-52). It is clear at Woolwich that the redware produced there (fabric E1) was basically one industry which could produce a range of slipped or unslipped, clear glazed or green-glazed vessels which correspond very closely to the wares from Guy's Hospital. Fabric E1 at Woolwich has been dated from the late 15th to the first half of the 16th century (*ibid*, 52). A similar redware fabric (fabric E2) was again produced at Woolwich between c 1660 and 1680 and this again included a slipware element (*ibid*, 52, 63, 72). 'Guy's-type' redware was also produced at Kingston upon Thames, Surrey in the late 15th/early 16th century (Hinton & Nelson 1980).

As a wider tradition, therefore, 'Guy's-type' redwares appear to date from the late 15th century until perhaps the middle of the 16th century, but a similar redware, sometimes white-slipped and green-glazed, continued in production well into the 17th century. These problems of definition relating to Guy's ware and other white-slipped redwares in the London area will hopefully become clearer after the publication of the post-medieval redwares from excavations in London (Nenk *et al*, in prep).

As far as Colchester is concerned, the definition 'Guy's-type' ware is taken here to mean both the late medieval and post-medieval fabrics, whether clear or green glazed. However, while some of the Colchester vessels have been identified as Guy's ware (eg Fig 127.3; Jacqui Pearce & Clive Orton, pers comm, 1988), doubts have been expressed about some of the other pieces (Fig 127.1-2) which are not quite like the Guy's ware found in London (Beverley Nenk, pers comm). It is possible that some of these could be Dutch slipwares (although the fabric is less sandy than normal), or they could have been produced at some other

location outside London, although this is unlikely to be Colchester itself given the rarity of the fabric here.

Despite its rarity in the town, 'Guy's-type' ware occurs in some of the better-dated contexts here. The clear glazed carinated bowl (Fig 127.1) is from a context of c 1525 (Stratified Group 14). This form compares closely with examples from Guy's Hospital (Dawson 1979, fig 10.144-7). The broad flanged bowl Figure 127.2 is from a context of c 1650 (Stratified Group 20), and a green-glazed bowl base also comes from a context of this date (Stratified Group 19; Fig 233.13). A carinated sherd from a feature associated with Figure 127.2 is almost certainly part of the same oxidised, brightly green-glazed vessel and indicates that the bowl was probably carinated just below the external incised zig-zag decoration. This is related to a distinctive 'Guy's-type' form which resembles a hybrid between a deep carinated bowl or pancheon (with a pouring-lip) and a shallow carinated pipkin (cf *ibid*, fig 14.72; Redknap 1987a, fig 8.4). A virtually complete example of this form came from an early 17th-century brick-lined pit on the 1986-7 Angel Yard site (40.86 F88). This has a sharply carinated form with a pouring lip, and it has an external incised wavy line and is green glazed inside. Figure 127.3, from a confused context, is slightly sooted externally and may represent an unusual form of shallow cauldron.

The most unusual item to be accommodated under the 'Guy's-type' category is represented by two fragments from a figurative, possibly anthropomorphic object, possibly from a lavabo, *aquamanile* or similar highly decorated form (Fig 228.1; Stratified Group 15, c 1525-50). The larger sherd has a crude knife-faceted rim or tubular spout. Below this a thick cordon has been modelled to resemble a cable; and the area below this, which may be thickening towards a handle or strut, has been roughened to resemble hair or fur. Except for the 'cable', the exterior is covered with white slip under a reduced greenish clear glaze of thick glossy post-medieval character. The other sherd is unslipped but glazed in the same manner on the rounded outer surface. It appears to represent part of a draped ?human arm or shoulder with a modelled cape hem. The whole thing is reminiscent of an anthropomorphic 'Toby jug'. The fabric is dark reddish-brown, relatively quartz-free and micaceous, rather like a post-medieval red earthenware (Fabric 40). There is a figural jug possibly in Guy's ware from the Guy's Hospital excavations, which is about the closest parallel to the figured sherds just described (Dawson 1979, fig 10a). However, the Colchester sherds resemble neither the Guy's ware fabric nor imported Dutch fabrics very closely (Beverley Nenk, David Gaimster, pers comm), so an alternative source must be sought. Although it is unlikely to be a Colchester product, the fabric does have some resemblance to early Fabric 40 and may have been made at Stock near Chelmsford or some other Central Essex-type ware production site (see above p 190).

Other forms represented include fragments of two cauldrons or pipkins with a partial internal slip under a green glaze. One of these, from Stratified Group 18 (c 1625-50), has a flanged externally beaded rim with a rod-sectioned handle and tripod feet (not illustrated; as *ibid*, fig 6.61). The other sherd (from an identical handle) is from the fill of a trench dug to undermine a bastion of the town wall shortly after 1648 (LWC NF7; see Fig 208). A few sherds from the tapering shoulder of a small jug, with a 'bib' of white slip and green glaze, represent the only example of this form (LWC AF11; 17th century).

The Colchester 'Guy's-type' vessels may not all come from London sources but some almost certainly do. As such they are interesting as the most northerly occurrence of the ware yet noted.

### Post-medieval red earthenwares (Fabric 40)

[Figs 128-129 & 247]

Weight: 597.44 kg

Number of sherds: 12,971\*

EVEs: 228.78\*

'Fabric 40' is a general term embracing a variety of post-medieval red earthenwares produced at many localities throughout Essex. Chronologically and technologically it is the successor to the sandier medieval red earthenwares found in Essex (Fabric 21). In general, it has a uniform orange-red fabric with fairly fine sand tempering and its unglazed surfaces have a smooth feel. It is very commonly glazed, either with a uniform clear lead glaze (showing brown or greenish-brown over the fabric), or less commonly with a black glaze or, even more rarely, with a brown mottled or iron-streaked glaze. Excluded from this classification is a class of dark red earthenware vessels, with a thick internal covering of white slip which were probably made in the north of England (Fabric 51A). Modern flowerpots (Fabric 51B) are also excluded.

In bulk terms (though not sherd numbers; see Fabric 13), Fabric 40 is the most common post-Roman pottery type

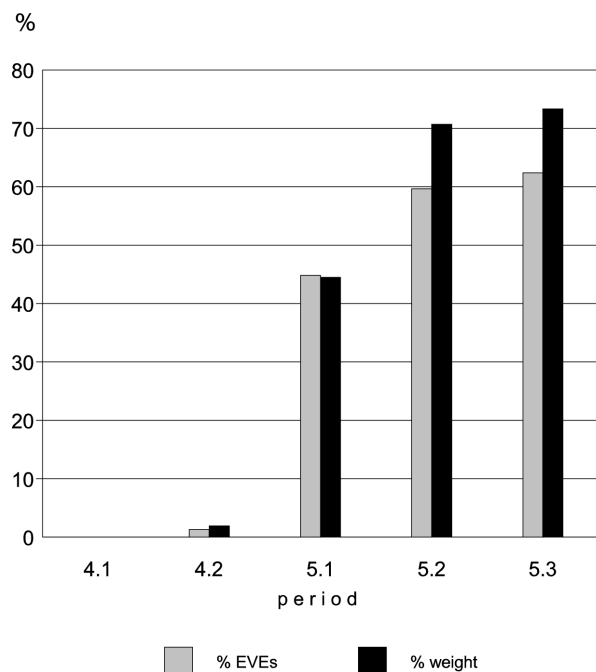

Fig 128 Post-medieval red earthenwares (Fabrics 40 & 40A): bar chart showing percentages in stratified contexts (ceramic periods).

found on excavations in Colchester, reflecting both the increased population and increased use of pottery in the town in the post-medieval period. Pottery of this type is known from late 15th-century contexts at Chelmsford in central Essex and was probably produced nearby (Cunningham 1985, 1, 73-4). This early Central Essex-type fabric is recognisable by its fineness. It has a dense, well-fired uniform texture with smooth surfaces often preserving the fine striations caused by throwing, as well as crisp fingerprints and other marks acquired while being handled in the wet state. At first, Central Essex-type Fabric 40 continued the late medieval forms and slip-painted designs of the East Anglian redware tradition (which included Colchester-type ware). Glaze, likewise, was used sparsely or not at all. During the first half of the 16th century, however, as Fabric 40 became the dominant coarseware in central Essex, so slip-painted designs went out of fashion or at any rate disappeared, the use of glaze increased, and vessel forms took on an increasingly 'post-medieval' look which involved the gradual disappearance of the sagging base and its replacement by the flat and pad base.

Further north, Colchester's own well-established pottery industry delayed the large-scale transition to Fabric 40 that had apparently happened over much of central Essex. By the middle of the 16th century, however, the essentially late medieval Colchester-ware industry declined and was superseded by vessels in Fabric 40. There is at present some difficulty in identifying local pottery groups of the second half of the 16th century, and this clouds the picture of precisely when post-medieval red earthenwares came to dominate in the town's ceramic assemblages. Without external corroboration, it is not normally possible to distinguish between a Fabric 40 assemblage of the second half of the 16th century and one of the first half of the 17th century. Exceptions to this picture are a pit group (LWC KF15) of c 1600 (see p 232). This, in addition to imported wares, produced three virtually complete Fabric 40 vessels illustrated in the typology below (a pancheon, Fig 134.29; a small bowl, Fig 138.70; a cup, Fig 146.146; and the base of a tripod pipkin, not illustrated). An important and much larger group of late 16th-century Fabric 40 vessels was found on the 1986-7 Angel Yard site (40.86 F76). This material lies outside the brief of this volume and awaits detailed analysis and publication. A stoneware medallion in this group bore the date 1585 but a date of c 1600 is suggested for the group as a whole. The contents of the Angel Yard group largely confirm the picture presented below and references to it are given where appropriate.

Fabric 40, like Fabric 21 before it, was produced over a long period of time at many different production centres throughout Essex (Fig 129) and beyond. There are many difficulties, therefore, in ascribing slight variations in form and fabric to different periods of time. Very few kiln groups have been methodically studied or published, and those that have been only confirm the high level of visual similarity that exists within the range of this basic utilitarian ware. Further work on kiln-sites and on well-dated pottery groups, however, should eventually permit a better understanding of both chronological and regional variations. Essex records of the 16th to the late 19th centuries contain an abundance of references to potters. For the bulk of these references, we can be reasonably confident that the type of pottery being produced by these potters was a post-medieval red earthenware (including Metropolitan slipware). There is no evidence of white wares being produced in Essex except

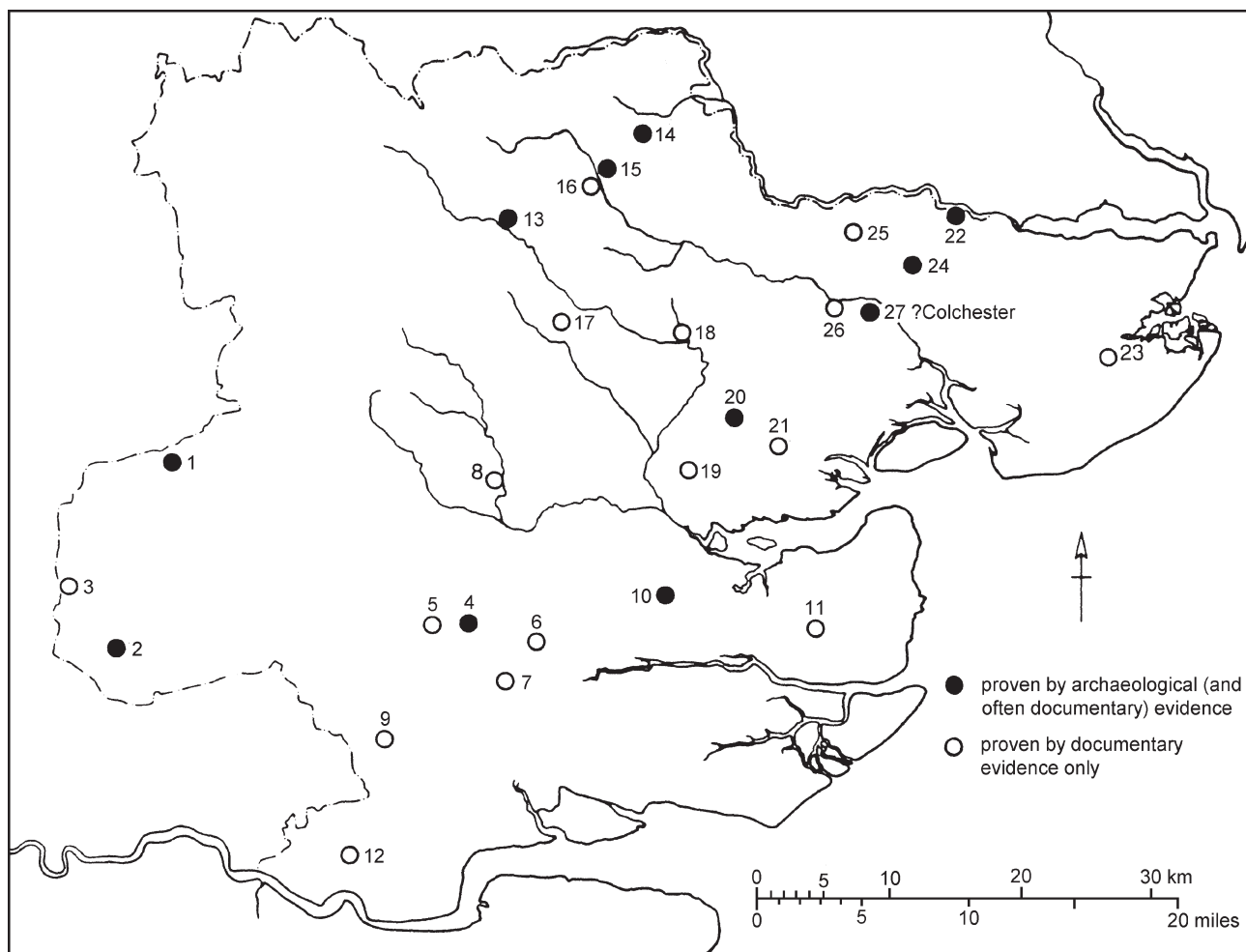

Fig 129 The location of post-medieval potteries in Essex, most, or all, producing red earthenwares.

Key

- |  |  |   |
|--|--|---|
| 1 Harlow and Latton (Newton <i>et al</i> 1960) | 10 Purleigh (Brears 1971; Potter 1990)     | 20 Tiptree (Appendix 2)   |
| 2 Loughton (Clark <i>et al</i> 1972)           | 11 Southminster (Brears 1971)              | 21 Tolleshunt Knights (Chapman Waller 1898, 6, no 150, 'Pot kilns') |
| 3 Waltham Abbey (Huggins 1976, 104)            | 12 Stifford (Brears 1971)                  | 22 Dedham (Emmison 1983; Appendix 2)                                |
| 4 Stock (Cunningham 1985, 83-8; Brears 1971)   | 13 Wethersfield (Brears 1971)              | 23 Thorpe-le-Soken (Appendix 2)                                     |
| 5 Buttsbury (Brears 1971)                      | 14 Gestingthorpe (Hills 1944; Brears 1971) | 24 Ardleigh (Erith 1964; Appendix 2)                                |
| 6 South Hanningfield (Brears 1971)             | 15 Castle Hedingham (Brears 1971)          | 25 Great Horkesley (Appendix 2)                                     |
| 7 Ramsden Bellhouse (Cunningham 1985)          | 16 Sible Hedingham (Corder-Birch 1985)     | 26 Lexden (Brown 1980)  |
| 8 Broomfield (Christy 1907)                    | 17 Braintree (Emmison 1957-8 & 1969)       | 27 Colchester (Brown 1968; this volume, p 191)                      |
| 9 East Horndon (Brears 1971)                   | 18 Coggeshall (Brears 1971)                |   |
|  | 19 Great Totham (White's Directory 1863)   |   |

occasionally by art potteries in the 19th century. Confining the survey to sources likely to have supplied Colchester, pottery kilns producing Fabric 40 at least in the 17th and 18th centuries are known from west central Essex at Harlow (Newton *et al* 1960) and Loughton (Clark *et al* 1972), which both produced Metropolitan slipware. Some amount of Metropolitan slipware and much black-glazed earthenware is known to have been produced at Stock, south of Chelmsford, at a similar date (Cunningham 1985, 83-8). Several batches of pots, over 400 at a time, were ordered in the years 1530-32 from 'John Pallmer of Stocke in Essex' for the hot-houses at Hampton Court and Hanworth. At least two of these batches were transported first to Colchester by

road and then by water to London, despite the fact that the Colchester journey was a 20-mile detour north-east (Musty 1977). Musty has suggested that the Stock potters may have run a regular delivery service to Colchester where their wares could be put on coastal traders bound for London (*ibid*). The parishes of Buttsbury, South Hanningfield and Ramsden Bellhouse adjacent to Stock were also producing pottery (Cunningham 1985, 83-8). Buttsbury still had an operating kiln in 1768 at which strong but coarse earthenwares were made from local clays (Brears 1971, 184). At Broomfield immediately north of Chelmsford, 'red glazed pans for use in dairies and the like' continued to be made until c 1850 (Christy 1907, 414).

A number of small potteries were in operation in the Heddingham area of north Essex. South-west of the Heddinghams, a pottery industry flourished at Wethersfield during the 16th and early 17th centuries (Brears 1971, 185). North-east of the Heddinghams was located the Gestingthorpe Pot Works which were in production from the 17th century until 1912, producing vessels with a rich orange glaze, sometimes dated and inscribed. Examples of these may be seen in Colchester Museum (Hills 1944; Brears 1971, 180-81). In the late 19th and early 20th century, George Finch, the last proprietor of the Gestingthorpe Pot Works, made long rounds by van to sell his wares. One round was in Suffolk, and another through Dunmow, while the third and longest round went through Chelmsford and lasted three days and two nights. Increasing transport costs, competition from Staffordshire and Lambeth, and old age, all eventually caused the closure of the old pot works. Even as late as 1912, however, George Finch Jnr set up a pot kiln at John Rayner's tile works only three fields away from the old works. This catered for local needs perhaps even as late as 1943 when George Finch died (Hills 1944).

In the first half of the 19th century, the Castle Heddingham Pottery was set up and produced coarse redwares until later in the century when Edward Bingham Jnr produced his celebrated art pottery (Brears 1971, 183). The Southey Green Works in Sible Heddingham was primarily a brick and tile manufactory, but in the late 19th century, and even as late as the Second World War, pottery and drainpipes were also made there (Corder-Birch 1985).

Several other potteries apparently lay within a fifteen-mile radius to the west and south-west of Colchester. Potters' wills of 1616 and 1728 testify to some potting activity at Braintree (Emmison 1957-8, 1, 206 & 1969, 3, 333). A pottery was worked at Coggeshall in the 1850s (Brears 1971, 180), and White's Directory of 1863 mentions a 'Pottery Farm' and also a George Butcher, shoemaker and earthenware- and drainpipe-maker at Great Totham. Fabric 40 wasters and kiln-furniture have been found by the writer at Potters Row, Tiptree, nine miles south-west of Colchester. These appear to be of 17th- or 18th-century date (see Appendix 2, p 369).

There is documentary evidence for potting activity at Dedham, six miles north-east of Colchester, in the mid 16th century, and documentary and archaeological evidence for the production of Fabric 40 there at least in the late 18th/19th century (see Appendix 2, p 368).

Eleven miles to the east of Colchester, at Thorpe-le-Soken in the Tendring Peninsula, a potmaker was active during the years 1750-57, producing 'extream good earthenware, well-leaded...' (*Ipswich Journal*, Oct 8th 1757, see also Appendix 2, pp 368-9). Only three miles north-east of Colchester at Ardleigh there is documentary evidence for potters and a kiln in operation between c 1583 and c 1780 (Erith 1964). The site of the Ardleigh kiln was tracked down by Mr Felix Erith in 1964; subsequently, the location of the kiln was visited by the author. A surface collection of pottery was made which consisted almost entirely of Fabric 40 and included wasters and kiln-furniture very similar in character to those from Tiptree and from the Colchester excavations generally (see Appendix 2, pp 367-8).

A pottery is said to have been set up at Colchester around the middle of the 18th century (Brown 1968, 157), possibly at Great or Little Horkesley 3.5 miles north-west of the town (A J F Brown, pers comm). This is supported by a reference

of 1755 to a potmaker of Great Horkesley (see Appendix 2, pp 364 & 367). However, nothing is known of the exact location of the pottery or of its products.

Excavations at Trinity Street in Colchester uncovered a wall of burnt peg-tile and a possible stokehole, both tentatively identified as a kiln (see above p 10). Peg-tile wasters were found scattered throughout the site and three near-identical 'flowerpots' (see below) also appear to be wasters. One would expect more pottery wasters than this if a pot kiln had stood here, so perhaps it was a tile kiln in which pots were occasionally fired. This is, perhaps, the most likely interpretation.

Around the middle of the 19th century a brickyard at Lexden, Colchester employed three workers who made pots as well as bricks (Brown 1980, 10). Again, nothing is known of the nature of these products but at this late date they may well have consisted largely of chimneypots, and flowerpots and other horticultural ceramics.

Clearly there were a great number of post-medieval potteries in Essex producing coarse red earthenware. The above summary is far from complete and largely ignores a great volume of more circumstantial evidence such as field names etc. Other potteries in south and central Essex have not been mentioned (but are shown on Fig 129), as these are less likely to have supplied Colchester. More detailed work on wills, tithe maps and other documentary sources will undoubtedly add to this list.

#### Problems in characterising Fabric 40

The fabric description given earlier is of course very generalised but is true for the majority of vessels in this fabric. As with many other types of pottery, the character of the fabric is affected by several factors, most notably the type of clay used in the first place; subsequent techniques of clay preparation; the size and intended purpose of the vessel; and lastly its firing conditions. There can thus be considerable fabric variation between, for example, a small fine-walled Fabric 40 drinking vessel with an oxidised fabric and a large thick-walled storage jar that may have been overfired and reduced. Underfiring would likewise create fabric differences. All this adds to the difficulty of deciding whether or not such differences reflect on the date or production area of a vessel.

Added to these difficulties, there is the problem of distinguishing between sherds of Fabric 40 and Dutch red earthenwares (Fabric 31). Both fabrics are relatively common in post-medieval Colchester, and both can be visually very similar. This is a problem common to coastal areas of southern England, particularly to East Anglia where post-medieval redwares were sometimes made in direct imitation of Dutch forms and using very similar clays (Jennings 1981, 134, 136). Colchester's own large community of Dutch refugees may well have influenced the shapes of locally made pottery. The hollowed, collared, flanged rims seen on local pipkins and some dishes and bowls were almost certainly inspired by pottery from the Low Countries where this has been a common rim form since the early middle ages. Fortunately, the potteries supplying Fabric 40 to the town rarely seem to have gone for wholesale imitation of Dutch redware forms but were largely satisfied with a general similarity. Dutch-style pulled feet, for example, which are common on Dutch dishes and a few cauldrons,

were apparently never imitated in Fabric 40. Similarly, pipkins and the rare cauldrons made in Fabric 40 have barrel-shaped bodies and flat bases which differ from the globular-bodied, sagging-based form common to Dutch pipkins and cauldrons (Hurst *et al* 1986, figs 59-60). Vessel forms are thus the most reliable method of distinguishing between the two fabrics. The fabric confusion is more acute for the late 17th and 18th centuries than for the earlier post-medieval period. This may be caused by a change of clay supply at some Essex potteries which switched to using a poorer-quality brickearth rather than true potter's clay. The result is a lighter, more thickly potted vessel with a bright orange glaze very similar in appearance to Dutch red earthenware. It is usually possible, however, to distinguish between the two. Dutch red earthenwares of the sort found in Colchester are generally made in a true potting clay with a uniform hard fabric full of well-sorted quartz inclusions, whereas the brickearth Fabric 40 has a fine matrix containing rather ill-sorted, often very coarse inclusions of quartz and red iron oxide along with buff or pale brown earthy inclusions, probably clay pellets or marl, sometimes occurring as streaks in the fabric. This pale inclusion appears to be virtually absent from the Dutch fabric.

Vessel forms and decoration on Fabric 40 are a more reliable indicator of date than detailed fabric analyses and where any chronological development has been observed this has been noted in the discussion of forms below. A much more detailed analysis of this fabric would be required to correlate variations in fabric character with variations in form to determine whether such variations can be attributed to chronological or spatial causes. This has been attempted to some degree, but with only limited success. Apart from the similarity of the fabric itself, the conservatism of certain basic forms and rim forms is quite evident. Nevertheless the following very general fabric distinctions may be made for the occurrence of Fabric 40 in Colchester:

#### *c 1500-1650: fine Central Essex-type fabric*

At the beginning of the 16th century, sandy Colchester-type ware was the dominant pottery type in the town. In a few pit groups of this date rare fragments of plain, largely unglazed Central Essex-type Fabric 40 have been found, mostly from jugs. Figure 226.10 (Stratified Group 13, *c* 1500-25) is possibly a true Chelmsford area product, with a typically fine fabric, and like many Chelmsford products it has a graffito at the base of the handle (Cunningham 1985, 70, fig 40.10-23). Only two or three sherds of slip-painted Fabric 40 were found on the excavations (eg in Stratified Group 12, *c* 1475-1525, not illustrated). This is hardly surprising considering the presence of Colchester-type ware's own vigorous tradition of slip painting. Figure 139.80 (Stratified Group 16, *c* 1550-1600) has the internally bevelled rim characteristic of Chelmsford cisterns. Fabric 40 bowls (eg Fig 134.25, 28-29) have simple flanged rims and sometimes slightly sagging bases. Glaze, which is confined to the inside of these bowls, is irregularly applied and stops well short of the rim. These features are survivals from late medieval bowls in Fabric 21. Rare condiment dishes in this fabric are also known (Fig 147.163). Although Central Essex-type Fabric 40 was never very common in Colchester, it appears to have been commonest in the late 16th and early 17th centuries, with some examples occurring as late as the mid 17th century.

#### *c 1550-1750/1800: 'standard' fabric*

This is by far the commonest type. It has a hard, well-fired, brick-red sandy fabric, often with a grey core. The inclusions are well-sorted and dominated by fine to medium-sized, sub-rounded quartz sand, followed by sparser coarse rounded red and black iron oxide and pale brown or buff clay pellets, rare very coarse flint, rare calcareous inclusions and abundant fine mica in the matrix. Vessels from contexts of *c* 1550-1650 are commonly a little overfired causing a lustrous dark purple-brown glaze which occurs mainly on the inside of vessels and stops at the rim. Some vessels have reduced external surfaces and oxidized internal surfaces or *vice versa*, often resulting in a greenish glaze where the surface has been reduced.

This 'standard' fabric is also that of the Fabric 40 potteries at Ardleigh and Tiptree which were the most likely suppliers of plain-glazed wares to the town. Although very similar to Metropolitan slipwares and black-glazed pottery (presumably made in central and west central Essex), yet there are subtle textural differences. In the later 17th and in the 18th centuries the 'standard' fabric declines both in quantity and quality. Even as late as the 19th century, however, some Fabric 40 vessels have a very similar fabric, but by this date there are usually more reliable indicators of date.

#### *c 1675-1850: low-fired and 'brickearth' fabrics*

From *c* 1675 onwards there is an increase in generally poorer-quality red earthenwares fired at lower temperatures than the 'standard' fabric. As mentioned above, the fabric now often has a very fine micaceous matrix but with ill-sorted, often very coarse inclusions, particularly earthy red iron oxide and pale brown or buff earthy clay pellets or marl which often occur as streaks following the grain or flow-direction of the fabric. The glaze is often a bright orange (like Dutch red earthenware), but of poorer quality, easily chipped and prone to scaling. The edges of broken vessels become easily abraded into a powdery buff state. Vessels overall are more lightweight than previously and the reduced strength of the fabric is sometimes compensated for by thicker, heavier rims and bases. A few brightly glazed pieces may be Gestingthorpe products (eg Stratified Group 21, Fig 242.58-59, Figs 243.72, 76 & 244.88; Stratified Group 22, Figs 245.23, 246.26 & Figs 142.107, 143.111, 118, 144.124 & 147.172).

Of similar date is a rarer but distinctive fabric, similar in composition to that described above but with a much coarser fabric dominated by very coarse, sub-rounded, pale brown or buff earthy inclusions (either clay pellets or marl), which are commonly up to 5 mm across. These give the fabric a coarse 'porridgey' texture and often erupt through the surfaces and the thick treacly dark brown glaze. Vessels are thickly potted. Two dishes in this fabric occur in Stratified Group 21 (*c* 1680-1700), Figures 242.56 and 243.71, the former having unusually thick and crackled trailed slip dashes on the rim. Large lug-handled storage jars (identical to Fig 141.92 but without indented rim) are known from 18th- and early 19th-century contexts, and a large globular flagon in this fabric bears the inscription 'J BRADBROOK 1805' (CM 4821.24).

#### *19th- and 20th-century Fabric 40*

Some of the possible sources for Fabric 40 during this

period have already been discussed. Most of the main established post-medieval Essex potteries disappeared or contracted sharply in the late 18th and 19th centuries, due probably to competition from the Staffordshire potteries and the changing social conditions of the time. The red earthenware vessels of this period consist almost entirely of large, robust garden jars or bread crocks, pancheons, some very large flanged lids and perhaps a few other forms. A large 'chicken feeder' in Colchester Museum from Elmstead Heath is probably of this date (CM.74.1971). The fabric is very much as the later 'standard' fabric described above, though often coarser. The Gestingthorpe Potteries continued producing wares with a bright orange glaze. The heaviness, uniform and often total glaze coverage, and generally 'modern' character of all these wares, however, is usually enough to allow them to be distinguished from earlier wares. Rouletting occurs on the shoulder of some jars (Fig 141.91) and on the sides of bowls. Heavy complex flanged rims are common (Fig 136.42 with 'JWS' stamp). The rims of Figure 142.98-99 are identical to examples found on jars and pancheons at Pot Kiln Field, Dedham (see above). Pancheons may be very large, glazed all over, and often have a pouring-lip (Fig 136.41).

**Typology**

[Figs 130-33]

The typological range is very diverse and many new, typically post-medieval forms (eg dishes) make their first appearance locally. Local forms display many general similarities with post-medieval coarsewares across the country in keeping with the rising level of standardisation in this period. Particularly close parallels may be seen between the

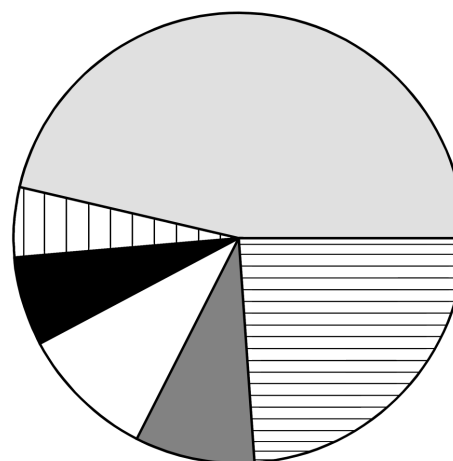

Fig 130 Post-medieval red earthenwares (Fabrics 40 & 40A): pie chart showing vessel assemblage by EVEs.

Colchester material and the large published post-medieval assemblages from Norfolk, such as Norwich (Jennings 1981, 150-86), Fulmodeston (Wade-Martins 1983), and to a lesser extent King's Lynn (Clarke & Carter 1977, 238-57). There are also close parallels with many forms in Surrey/Hampshire Border ware (Pearce 1992), a widely circulated white ware whose forms the Essex redware potters almost certainly tried to imitate.



Fig 131 Post-medieval red earthenwares: group of miscellaneous forms — height of cistern left of centre 347 mm.

*Dishes* (Figs 132.1-10 & 133.11-24)

All dishes from the excavations are broadly similar, though with many slight variations. Two-thirds (65%) of all dishes are flat-based with short, straight, flaring sides and broad flanged rims (Fig 132.1, 4-5, 7-10). The most common type of rim is a plain, slightly angled, flanged rim, slightly thickened at the end and normally with a single groove near the edge of the flange and one or more grooves at the internal angle (eg Fig 132.4, 8, 10). Slightly hollowed versions of the same are almost as common (Fig 132.1), followed by a smaller number of beaded flanged rims (Fig 133.11), and then a few rarer types. A relatively small number of dishes (8%) are identical to the common straight-sided type but differ in having curved sides (Fig 133.11). For the most part, however, the curvature is so slight (and is sometimes the result of knife-trimming) that the difference has little significance. More than a quarter (27%) of all dishes are flat-based and straight-sided with no change of angle in profile and consequently with simple or thickened rims. The positioning of grooves on the inside, however, mimics that of dishes with true flanged rims (Figs 132.2-3, 6 & 133.15-16, 20-21).

Rare dish forms include Figure 133.22-23, both with pad bases, and no 24. These could be dishes or bowls, depending on one's point of view. Figure 133.23 is very similar in form to some Dutch slipware bowls, including one dated 1623 (Hurst *et al* 1986, fig 74). Figure 133.24 may actually be a chafing dish. All dishes are covered internally with a clear glaze and are unglazed externally apart from accidental splashes. The only exception is a small black-glazed dish with a piecrust rim (Fig 133.18; Stratified Group 21, c 1680-1700). Combed and incised decoration is reasonably common on dish flanges. Three or four dishes have a 'Maltese cross' stamp on the rim (Fig 133.11-12), a device which also occurs on locally made post-medieval dishes at King's Lynn, Norfolk (Clarke & Carter 1977, fig 115.195c). The square grid stamps on Figure 132.9 are so far unique. Diameters for all Fabric 40 dishes range from 160 mm to 540 mm, the largest diameters being those of a few 18th-century Metropolitan slipware 'chargers' (eg Fig 154.206-207). There is a minor cluster of sizes around 200 mm, a major cluster between 280 and 340 mm, and another minor cluster around 420 mm. This appears to be a conscious attempt to produce three standard sizes of dish separated by 4-inch (100 mm) intervals: ie small dishes of 8 inches' diameter (almost 200 mm); medium dishes of 12 inches' (almost 300 mm) and large dishes of 16 inches' (almost 400 mm) diameter. A very similar size range has been noted for Metropolitan slipware dishes at Norwich (Jennings 1981, 97).

Dishes show very little typological development. The two main types span the 17th century and the first half of the following century. A single dish with 'Maltese cross' stamps (as Fig 133.11-12) came from Stratified Group 16 of the second half of the 16th century, but not from any other of the extremely few contexts of this date. The same stamped device is also known from contexts of the second half of the 17th century. Dishes are noticeably few in early 17th-century contexts but occur in profusion in the second half of the century. Stratified Group 21 (c 1680-1700) produced a minimum of around 60 dishes in a variety of wares including Fabric 40, Metropolitan slipware (Fabric 40A), tin-glazed earthenware, Surrey/Hampshire Border ware and German slipwares. Fabric 40 and Metropolitan slipwares accounted for a third each, and the other wares accounted for the

remaining third. In Stratified Group 22 (c 1730-40), which contained a similar range of wares with the addition of Chinese porcelain and Staffordshire slipware dishes, the combined amount of Fabric 40 and Metropolitan slipware drops to less than a quarter of all dishes present. Finally in a brick-lined latrine (LWC VF1), which contained a range of pottery and clay pipes of c 1740-1840, there are no Fabric 40 dishes at all but a similar range of wares to the preceding groups with the addition of Staffordshire white stoneware and Pearlware dishes/plates. These, and many similar observations, suggest that plain Fabric 40 dishes went out of use c 1725-50, although decorated Metropolitan slipware remained in fashion for a little longer (presumably coming from central Essex kilns). By the middle of the 18th century, the growing variety of decorative tablewares available to Colchester householders appears to have completely eliminated the need for tablewares in locally produced red earthenware.

*Bowls* (Figs 134.25-31, 135.32-37, 136.38-50, 137.51-61, 138.62-72 & 139.73-79)

This is a large and diverse category. The illustrations have been arranged roughly in order of similarity, sometimes irrespective of the main categories under which they have been studied, eg straight-sided, curved sides, flat base etc. While these categories are meaningful for the study of certain forms it is evident that certain secondary characteristics, eg handles, height, diameter etc, permit more meaningful groupings which probably reflect vessel function but which cannot always be rigidly classified. Such variation is only to be expected when studying a large collection of vessels which, though broadly similar, could have been made centuries apart and at differing production sites.

The main categories of bowl may be summarised in order of frequency:

*Form B5.* Bowls with straight sides and flat bases (39% of all bowl sherds). These, in order of importance, consist of large pancheons, generally over 300 mm in diameter (eg Fig 135.32-36); smallish, often handled bowls, generally under 200 mm in diameter (eg Fig 137.51-54); and medium-sized bowls generally between 200 and 300 mm (eg Fig 231.43-45, 47-48).

*Form B3.* Bowls with curving sides and flat bases (34%), consisting mainly of smallish and medium-sized vessels, often handled, with diameters generally between 150 and 300 mm (eg Fig 137.56-57) and a much smaller number of pancheons (eg Fig 231.20-21, Stratified Group 17).

*Form B6.* Small carinated bowls (9%, eg Fig 138.72).

*Form B4.* Bowls with straight sides and sagging bases (8%, eg Fig 134.31).

*Form B2.* Bowls with curved sides and sagging bases (5%, eg Fig 134.25-26).

*Form B1.* Hemispherical bowls (also 5%, eg Fig 139.73-79).

The diameter range for all bowls is 90-600 mm. There are marked clusterings around four points within this scale, ie 160 mm, 280 mm, 380 mm and 480 mm. As in the case of dishes, though less obviously, there was probably a hierarchy of sizes separated by four inches' (100 mm) difference. Virtually all bowls are covered to varying degrees with a clear glaze on the inside only. Few bowls are completely covered with glaze, and black-glazed bowls are very rare.



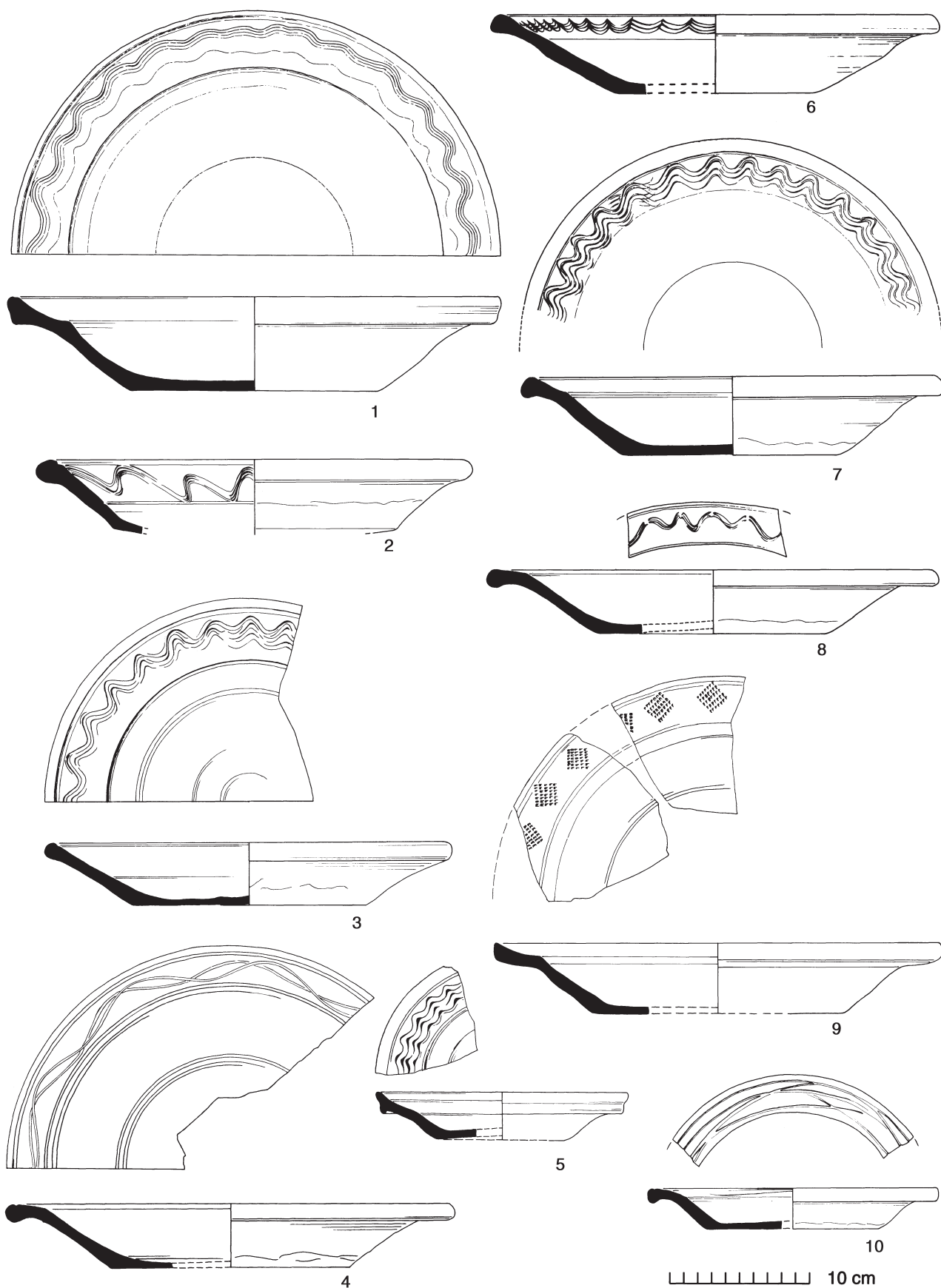

Fig 132 Post-medieval red earthenwares: dishes with decorated rims (nos 1-10). 1:4.

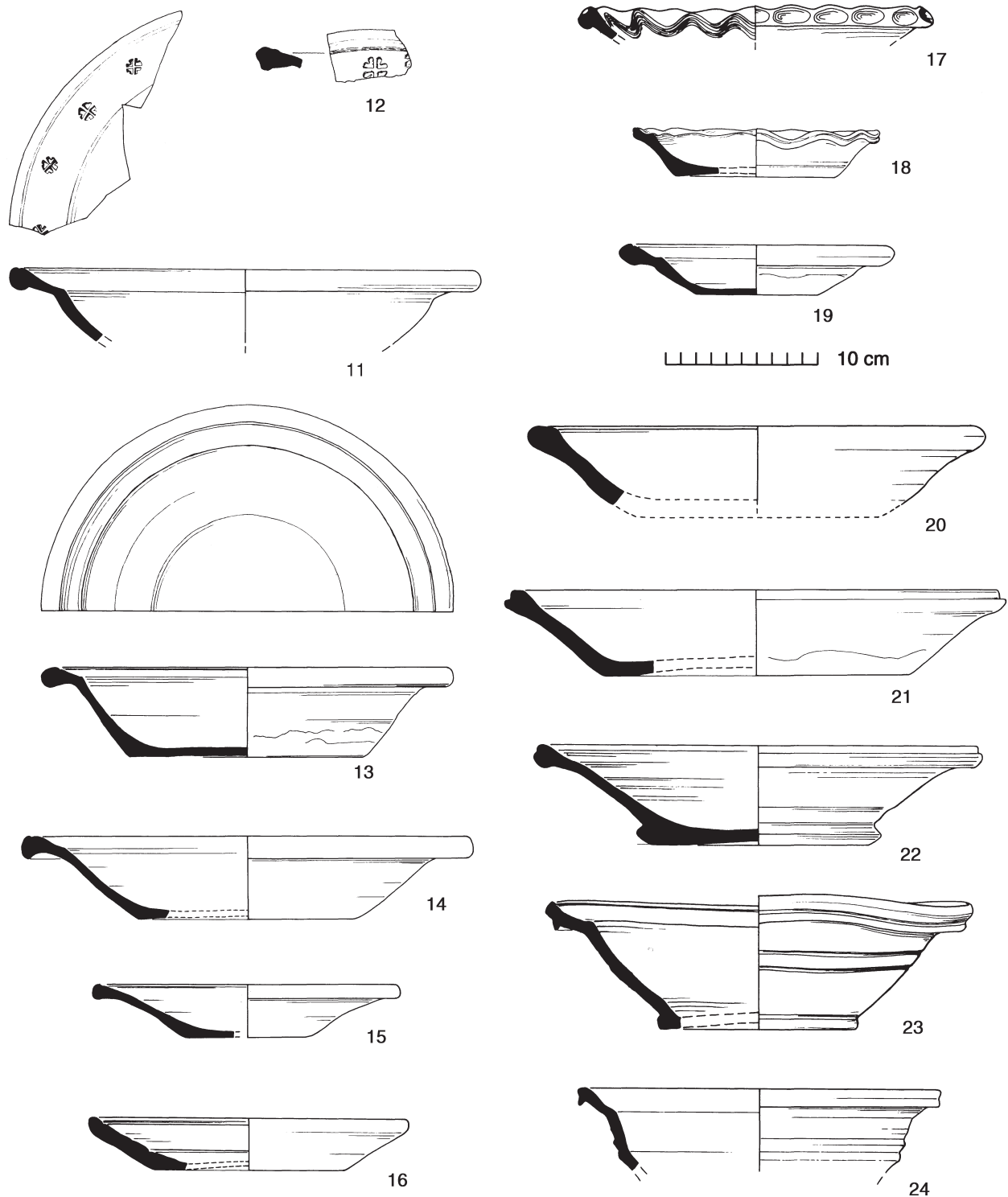

Fig 133 Post-medieval red earthenwares: dishes (nos 11-24). 1:4.

Decoration is limited to external grooving, frilled collared rims and rare incised zig-zags on the flanged rims of one or two late 17th-century handled bowls (not illustrated).

Large bowls or pancheons with curving sides and sagging bases (Form B2, Fig 134.25-28), occur predominantly in late 16th- and early 17th-century contexts. The sagging base and sparing internal use of glaze hark back to late medieval

forms, though some still turn up in mid 17th-century contexts (Fig 134.28). Straight-sided pancheons with sagging bases (Form B4, Fig 134.29-31) were probably current in the second half of the 16th century. Figure 134.29, in Central Essex-style fabric, is from a pit context of c 1600 (see p 149; LWC KF15). But many examples (in particular as Fig 134.31) are known from the early-mid 17th century. A few sagging bases were obviously caused by excess

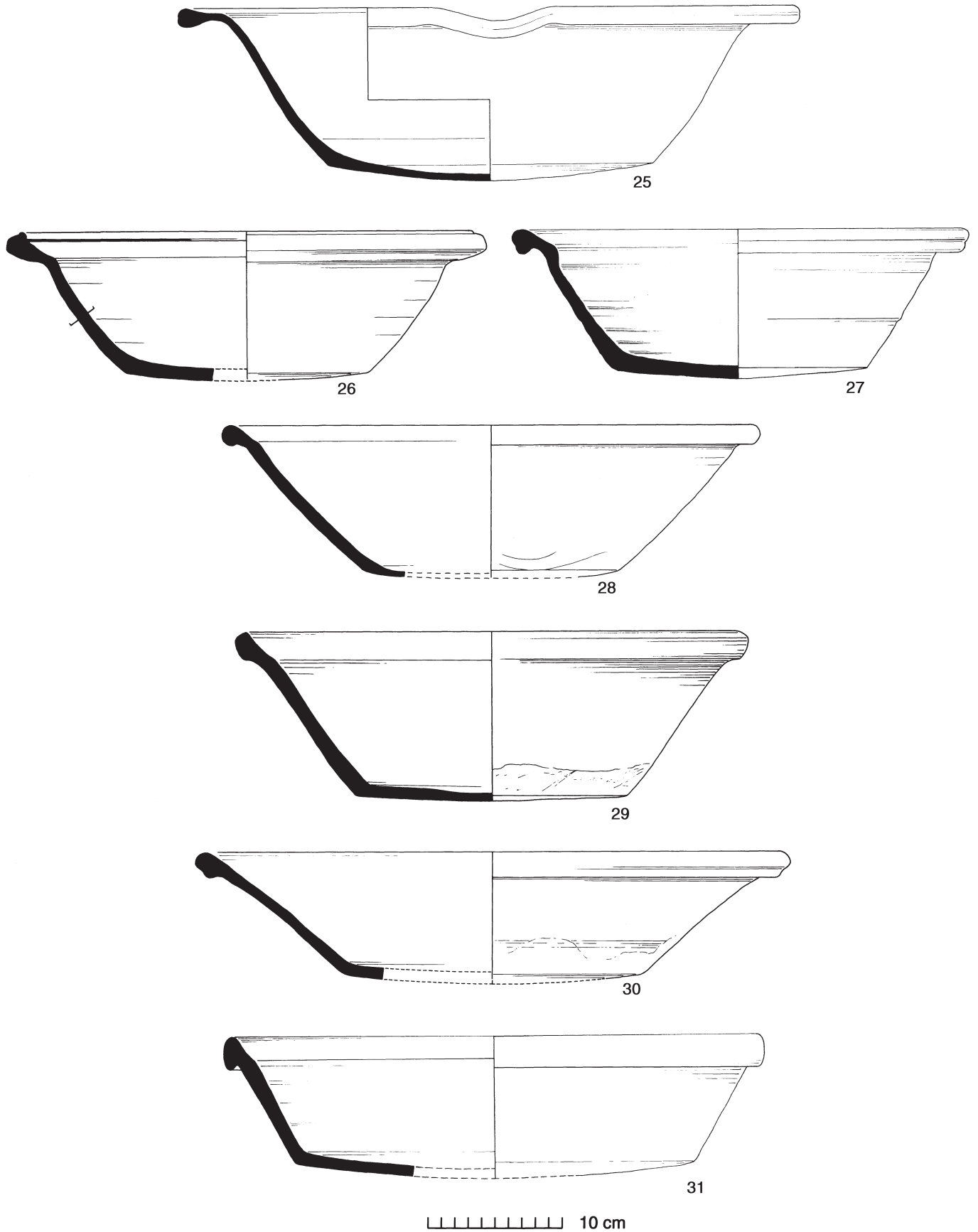

Fig 134 Post-medieval red earthenwares: large bowls or pancheons with sagging bases (nos 25-31). 1:4.

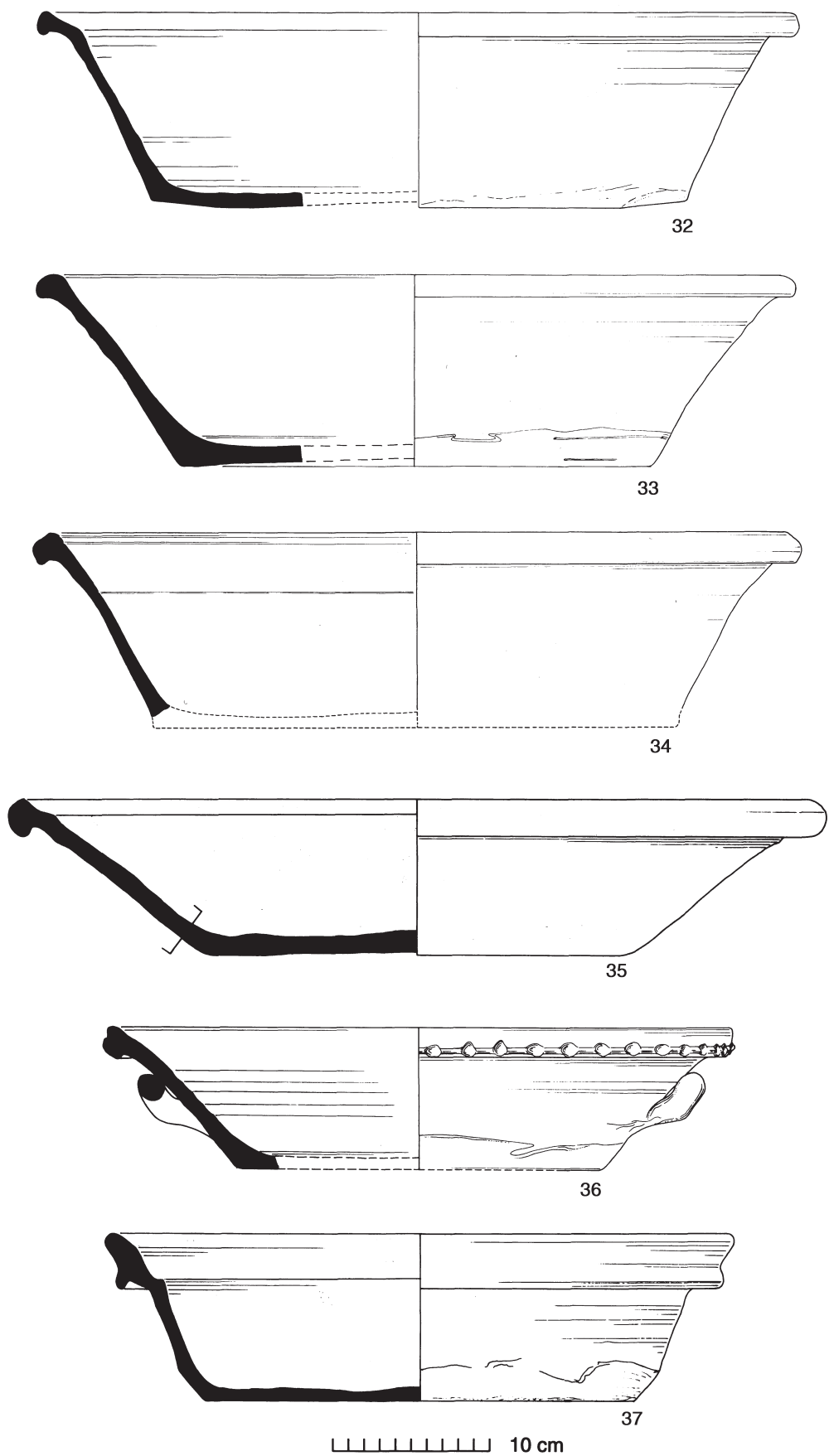

Fig 135 Post-medieval red earthenwares: large bowls or pancheons (nos 32-37). 1:4.

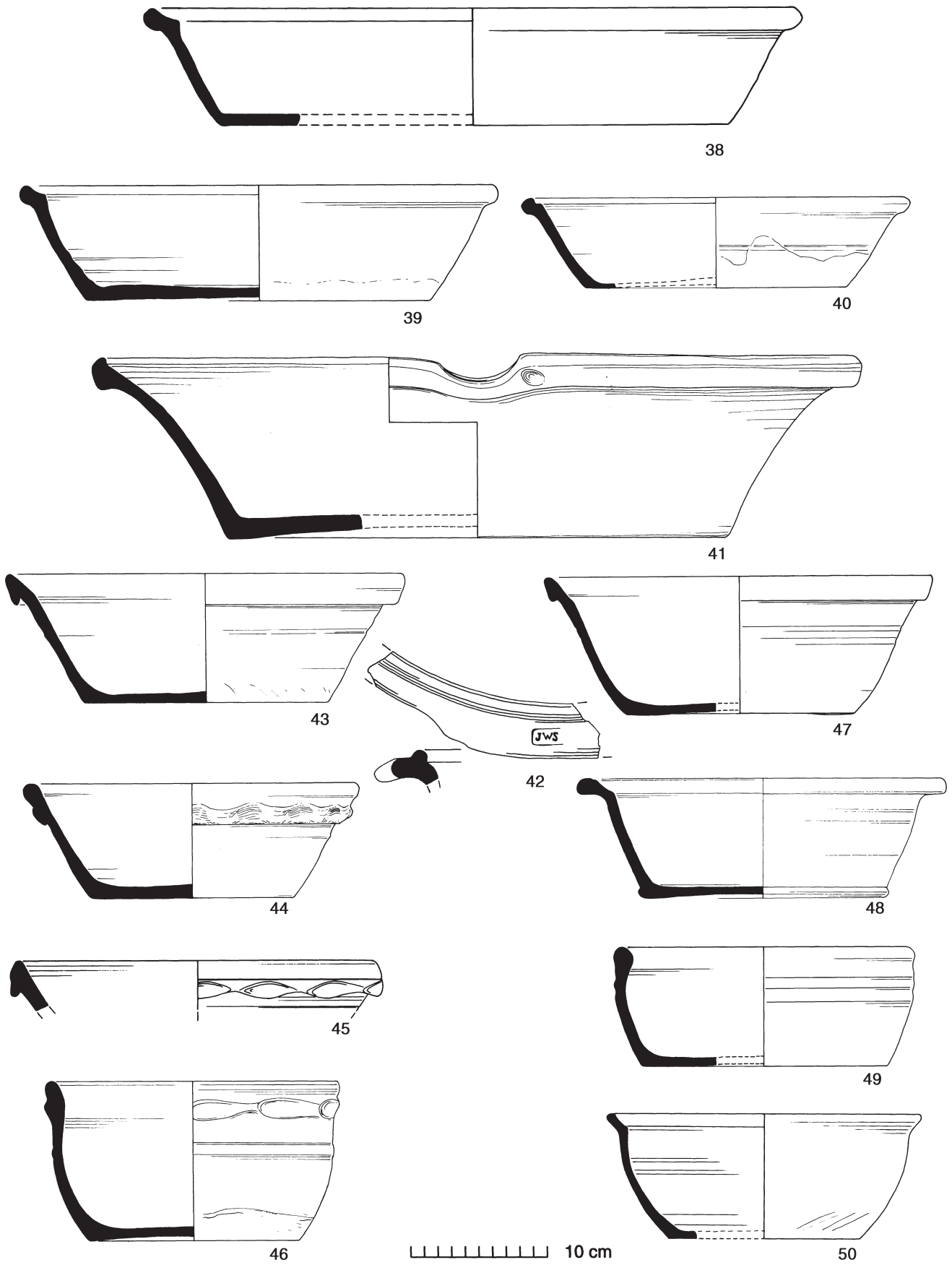

Fig 136 Post-medieval red earthenwares: large bowls or pancheons (nos 38-42); medium-sized bowls (nos 43-50). 1:4.

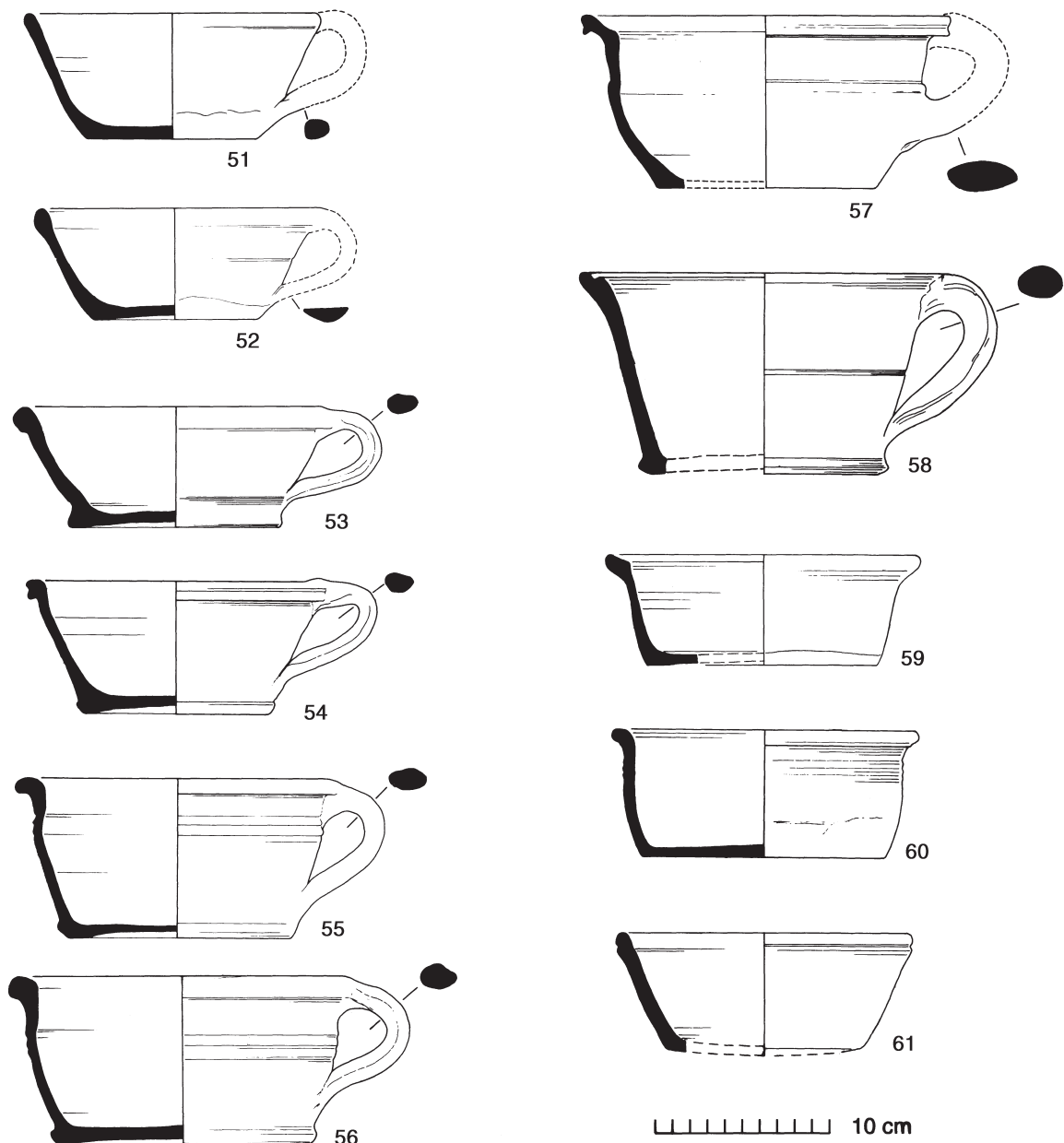

Fig 137 Post-medieval red earthenwares: small-medium handled bowls (nos 51-58); small straight-sided bowls (nos 59-61). 1:4.

knife-trimming of the basal angle or by warping in the kiln, but although the sagging base had effectively disappeared by the second half of the 16th century, a few apparently intentional examples occur even as late as the 18th century (Fig 245.21; Stratified Group 22, c 1730-40). Wide pancheons with curving sides and flat bases are comparatively rare (Fig 231.20-21; Stratified Group 17, c 1625-50). The presence of a pouring-lip on several pancheons suggests they were primarily intended for dairy purposes.

Form B5A is the common flat-based, straight-sided, large pancheon (Figs 135.32-37 & 136.38-42). The commonest type is that of Figure 135.32-34. These have simple heavy flanged rims, or thickened and beaded rims, sometimes with an internal groove as though to mimic a flanged rim (Fig 135.34). The internal glaze is often reduced and greenish. These are particularly common in the second half of the 17th century and the first half of the following century. Straight-sided pancheons were made in Fabric 40 right up

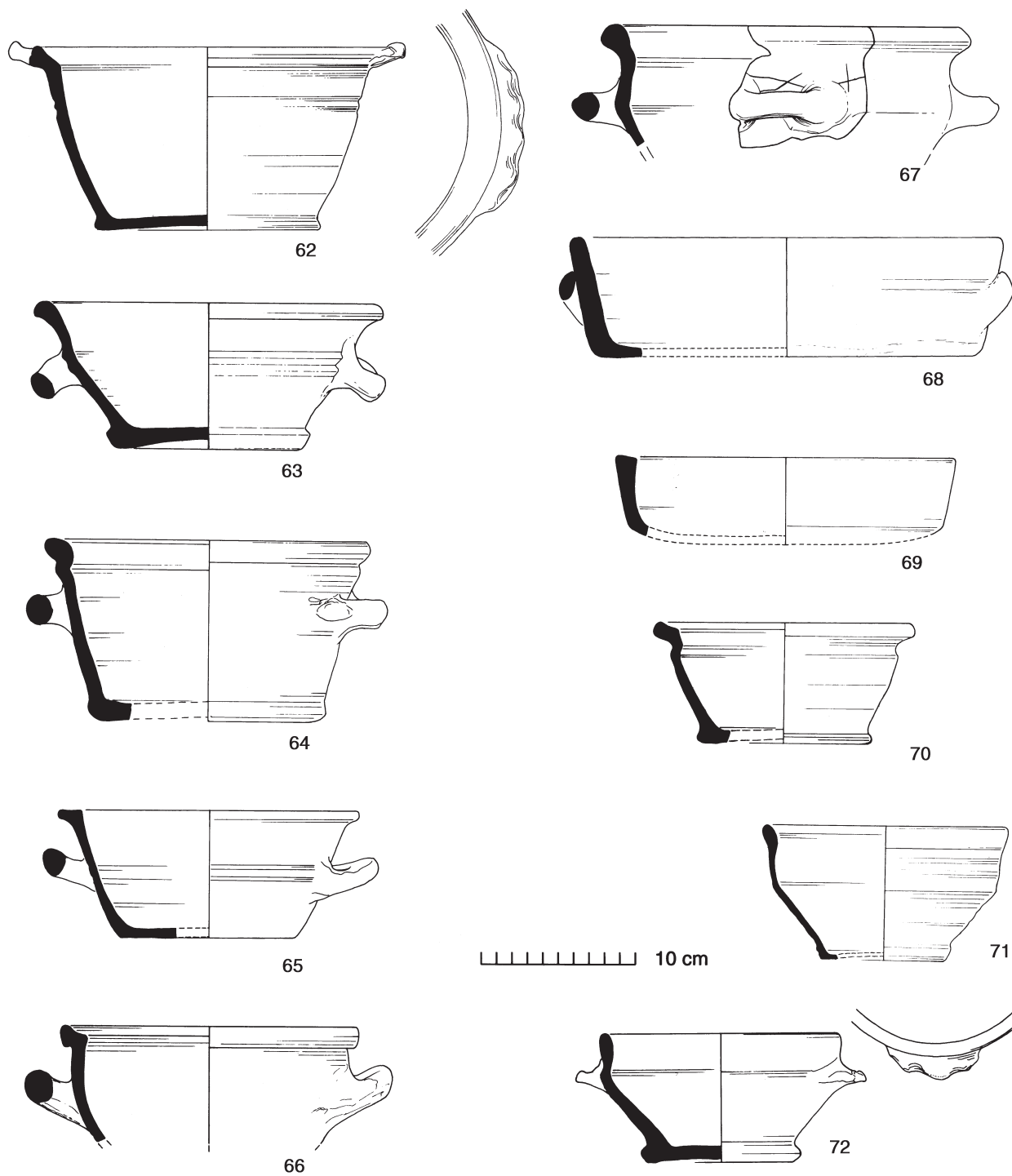

Fig 138 Post-medieval red earthenwares: small-medium bowls with paired handles (nos 62-67); shallow bowls or dishes (nos 68-69); carinated bowls (nos 70-72). 1:4.

to the 1940s. In the first half of the 18th century there was a variety of thick-walled pancheons in poorer-quality fabric (Fig 135.35-36). The collared rim with notched dimples and the arched-lug handle are features also found on 18th-century jars (eg Fig 141.92, Stratified Group 22). Pancheons of the 19th and early 20th century are recognisable by their large size, their regularity, and their uniform glaze which frequently covers both the inside and outside

(Fig 136.41, from a context of c 1837-62; and Fig 136.42). Rims tend to be heavy and may be simple and thickened or complex, bifid and flanged. Pouring-lips and horizontal ledge-handles attached to the rim are also quite common.

The unique 'JWS' stamp on the rim of Figure 136.42 has not been positively identified. However, the last initial could stand for the surname Sadler which was the name of one

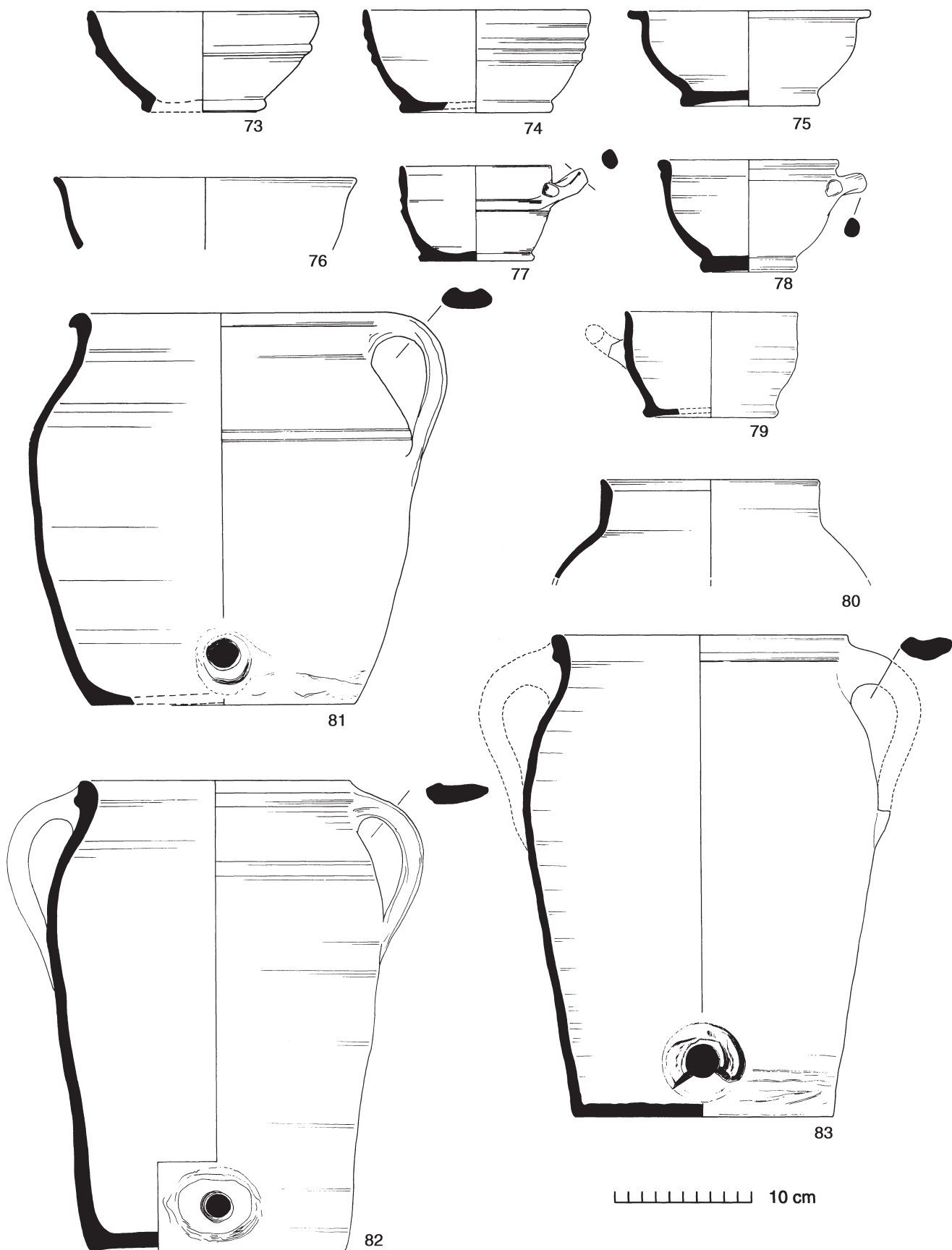

Fig 139 Post-medieval red earthenwares: hemispherical bowls (nos 73-76); porringers (nos 77-79); cisterns (nos 80-83). 1:4.



family of owner/occupiers of the Ardleigh pottery kiln during the 18th century (see Appendix 2, pp 367-8). There was a Jonathan Sadler at Ardleigh in 1738 but this is probably too early. The surname was also used by a family of tilers and brickmakers at Ardleigh in the 19th century and one tile in Colchester Museum bears the inscription 'July 11th, 1821, J Sadler, King George 4th' (CM 5465.27). The stamped bowl might be evidence of continued pottery production at Ardleigh into the early 19th century, although there is always the possibility that it was produced elsewhere in Essex or even beyond.

Figure 136.43 and 47 are common medium-sized bowls or pancheons of the first half of the 17th century. A common form of decoration in the late 17th and early 18th centuries is a frilled collared rim (Fig 136.44-46), occurring on both straight and curved-sided bowls (and on jars but not bowls in the early 17th century).

Smallish handled bowls occur in both straight and curved-sided forms with either flat or pad bases. The most distinctive form has a single vertical loop handle, flaring walls and a plain or beaded rim (Fig 137.51-58). This is a particularly common form in contexts of the second half of the 17th century and continues well into the 18th century. Figure 137.53 is identical in form to a Metropolitan slipware bowl dated 1659 (Hodgkin 1891, 12, no 39). Some of the larger bowls of this type (Fig 137.56-58) could conceivably have served as chamberpots, but a more general food preparation or serving purpose seems more likely. Some (as Fig 137.52) are sooted and the base is heavily worn on the side opposite the handle (also seen on jars eg Fig 142.103). Small, plain, mainly straight-sided bowls (Fig 137.59-60, both Stratified Group 17, and Fig 137.61) are common in the first half of the 17th century.

Solid, frilled lug handles (Fig 138.62, Stratified Group 20 & Fig 138.72), particularly when attached to the rims of bowls, are features indicative of the early 17th and perhaps even late 16th century. Similar handles occur on early 16th-century Colchester-type ware bowls and jars as well as later Fabric 40 jars. Small to medium-sized bowls with pairs of horizontal loop handles (Fig 138.63-67) become common from the mid 17th, until well into the 18th, century. These may be glazed all over. Figure 138.67 (Stratified Group 21) has been incised, while still leather-hard, with rough crosses which are partly obscured by the attachment of the handle. The unusual form of this bowl and the incised markings (perhaps serving as a guide for positioning the handles), may indicate the work of an apprentice potter. In the 18th century, bowls and jars often have arched lug handles and are frequently glazed all over (Fig 138.68).

Carinated and hemispherical bowls (Figs 138.70-72 & 139.73-75) are relatively rare and tend to be early 17th century and glazed all over. Figure 138.70 is from a context of c 1600. Rare black glazed bowls include Figure 139.74 and 76 (Stratified Groups 20 & 21), the latter possibly imitating the form of more elegant tin-glazed bowls. Small hemispherical bowls (Fig 139.77-79) with a single horizontal loop handle may be the Fabric 40 equivalent to tin-glazed or Border ware porringers (Pearce 1992, fig 26). These are known only from a few early 18th-century contexts but the fabric quality of Figure 139.77 (unstratified) suggests an early 17th-century date.

Jars (Figs 139.80-83, 140.84-90, 141.91-97, 142.98-107, 143.108-118, 144.119-130)

This is the largest and most diverse category in Fabric 40, accounting for nearly half of all vessel forms. The diameter range for all types of jar is 70-400 mm; the vast majority falling between 100 and 280 mm rising evenly to a peak diameter of 180 mm. The main types of jar are summarised below in order of frequency:

*Form C16.* Large storage jars (38% of all jars by EVEs, eg Fig 140.84-90).

*Form C4.* Fairly small jars with narrow bases. Generally neckless. Lower body straight, upper body usually smoothly curved. Width about same as height (32%, various types, eg Fig 142.100-107).

*Form C10.* Pipkins with tripod feet, grooves on upper body, and lid seating (25%, eg Fig 143.113-118).

*Form C15.* Cisterns (4%, eg Fig 139.80-83).

*Form C7B.* Skillets. Usually with bowl-shaped bodies, tripod feet and a skillet-type handle (1%, eg Fig 144.121-124).

*Form C13.* Cauldrons, with flat base, tripod feet and a pair of cauldron-type handles (rare, eg Fig 152.190).

Cisterns (Fig 139.80-83)

Cisterns, whose functions included the brewing and storage of ale and beer, are relatively uncommon in Fabric 40. About twenty probable examples have been identified but a minimum count based on bung-holes gives only seven vessels, which is little more than 10% of the minimum vessel count for 15th-/16th-century cisterns in Colchester-type ware (66 vessels, see p 134). The sudden contraction in the numbers of cisterns in the later 16th and the 17th century may be a reflection of the decline in domestic ale-brewing in favour of beer-drinking; from the 15th century onwards, beer was purchased from a small number of large-scale brewing establishments in Colchester, often run by Dutchmen (Britnell 1986, 197).

All cisterns are unglazed apart from a few accidental splashes. Two cisterns occur with the fine Central Essex-type fabric and internally bevelled rim form of 16th-century Chelmsford cisterns (Fig 139.80, Stratified Group 16). A further, largely complete cistern of this type came from an Angel Yard context of c 1600 (40.86 F76, see above). Most 17th-century cisterns have a standardised appearance as regards shape, rim form and size (Fig 139.82-83; see also Stratified Group 20, Fig 239.50). Figure 139.81 was residual in a 19th-century context and may be later in date than the others. Figure 139.83 is from a late 17th- or early 18th-century context (containing much mid 17th-century tin-glazed pottery). Otherwise, there are no certain examples of cisterns from 18th-century contexts and the form does not occur in any other fabric.

Large storage jars  
(Figs 140.84-90, 141.91-97 & 142.98-99)

Early 17th-century storage jars (and probably late 16th-century as well), are best represented by those from Stratified Group 20 (Figs 237.42, 238.45-48 & 239.49). The similarity of storage jars from this group (which may be an apothecary's dump), somewhat exaggerates the frequency with which storage jars of these kinds are found from elsewhere in the town. Storage jars with a thumbled strip applied

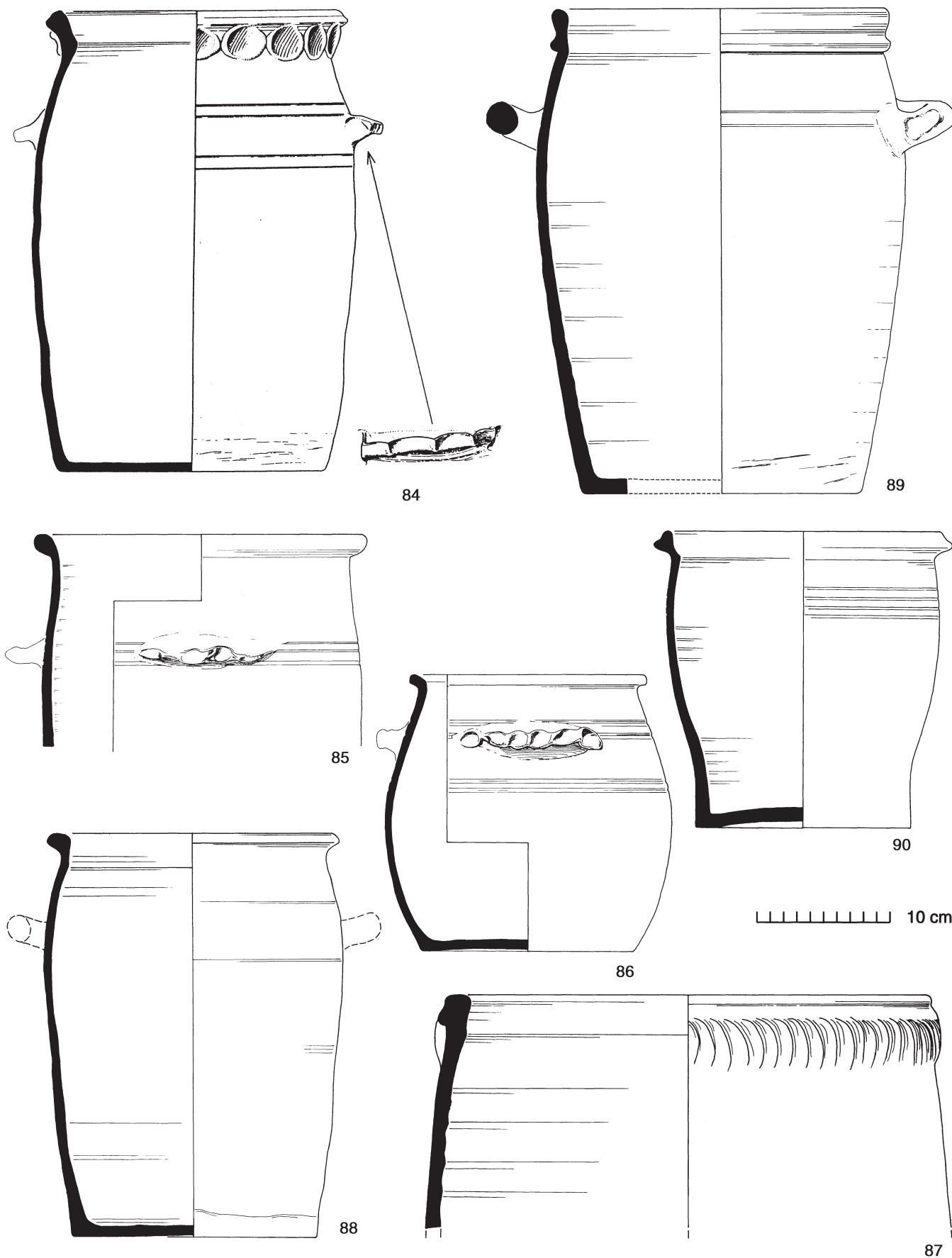

Fig 140 Post-medieval red earthenwares: large storage jars (nos 84-90). 1:4.

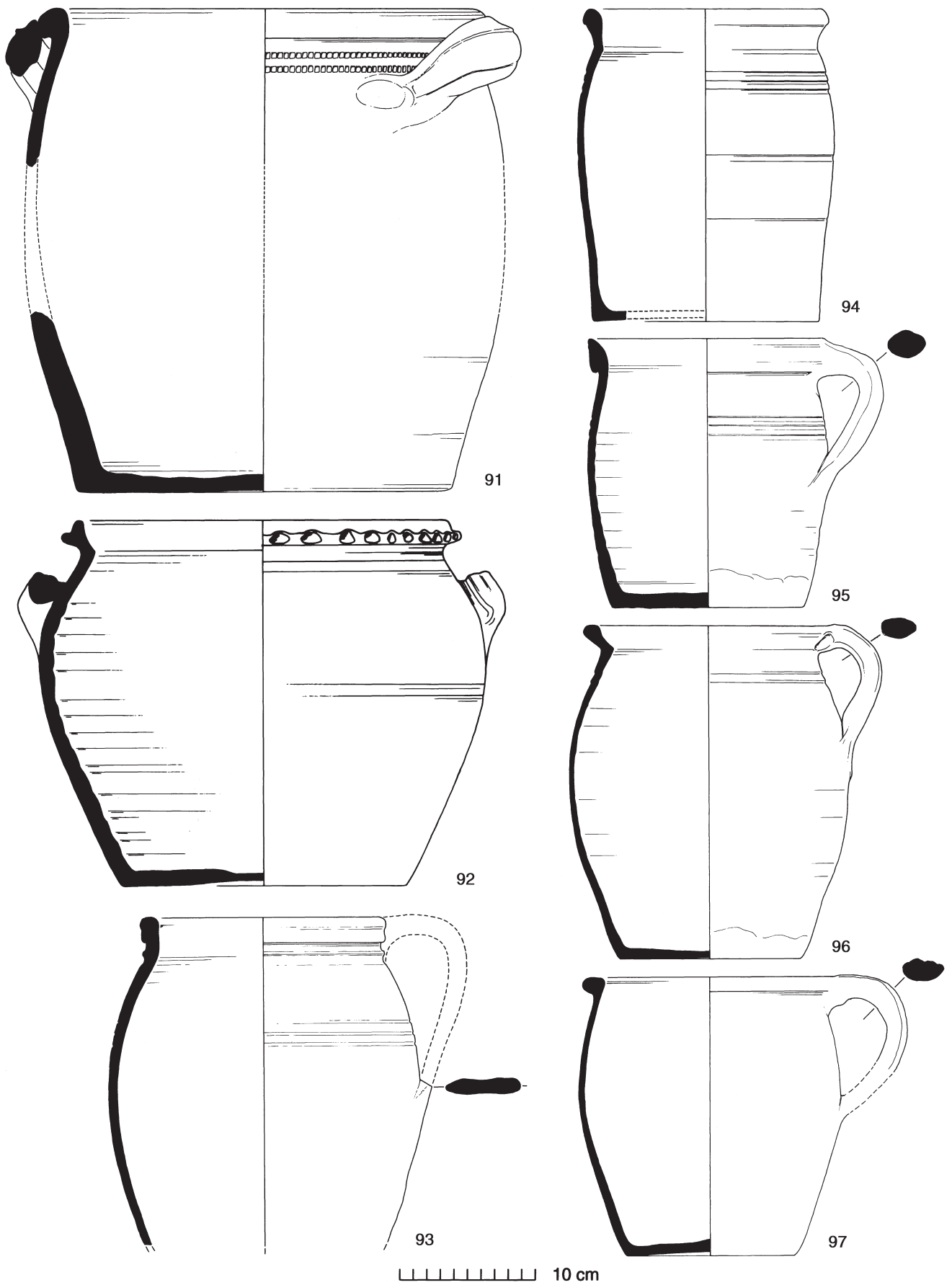

Fig 141 Post-medieval red earthenwares: large storage jars (nos 91-94); smaller storage jars (nos 95-97). 1:4.

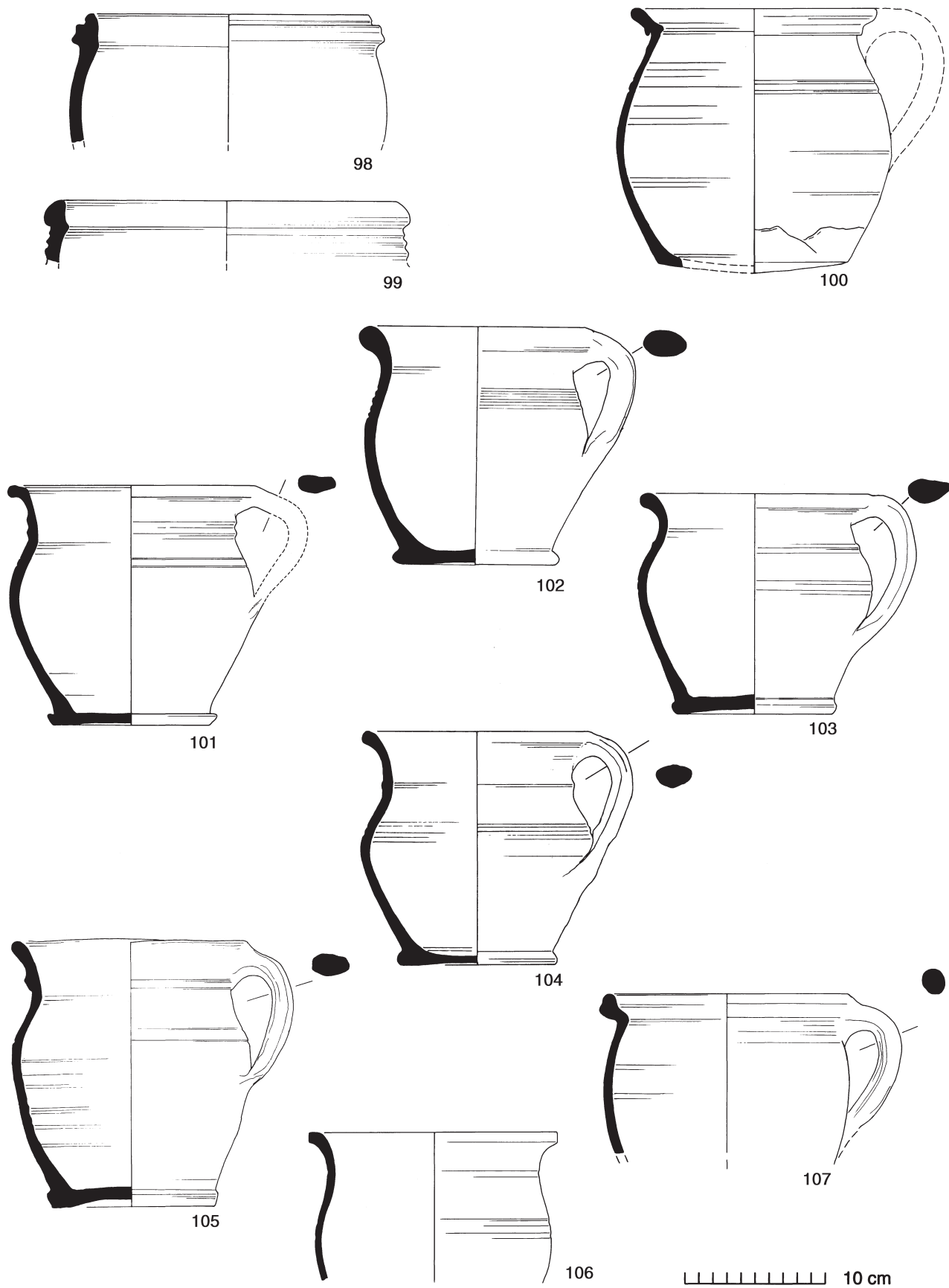

Fig 142 Post-medieval red earthenwares: smaller storage jars (nos 98-100); smaller handled jars or chamberpots (nos 101-107). 1:4.

below a barely flanged rim, and often accompanied by a pair of frilled ledge handles (eg Fig 140.84), are almost as common in this one context as they are from the rest of the town put together. The smaller jar (Fig 140.86) is almost certainly derived from this same group. The jars in Stratified Group 20 occur in a hard, somewhat overfired coarse fabric not greatly dissimilar to late medieval Colchester-type ware, from which tradition the applied thumbed strips and frilled ledge handles are obviously descended. They are clear glazed inside and were fired upside-down.

Figure 140.85, from a late 17th-/early 18th-century context, is a late survival of the use of frilled ledge handles, though without a thumbed strip and with a simple heavily beaded rim. One of the six buried storage jars from the house at Middleborough (Fig 152.192; see pp 219-21) has a pair of frilled ledge handles and a sagging base and, most unusually, is completely covered with a black glaze. It may already have been old when it was buried around the mid 17th century. The use of applied thumbed strips below the rim continued throughout the 18th century (Fig 140.87, mid to late 18th century) and into the 19th century, but at this date the overall glaze and presence of arched lug handles is sufficient to distinguish the later jars from the earlier ones. Furthermore the thumbing on later jars tends to be more crowded and overlapping as on Figure 140.87.

Stratified Group 20 also contains possibly the earliest occurrence of two types of decoration that become common later on in the 17th century, particularly on bowls and jugs; ie frilled or thumbed (but not applied) decoration along a collared rim (Fig 238.45), and lightly thumbed facets down the back of the handle (Fig 237.42). Figure 140.88 represents the commonest type of large storage jar found in contexts of the mid 17th to early or mid 18th century. An identical example came from the Sheepen Farm siege fort constructed and abandoned in 1648 (Fig 150.187, see pp 218-19) and a similar buried example from Middleborough contained a token of c 1660 (Fig 152.191, see p 219). These, like many large storage jars, have a subdued or barely-flanged rim causing an internal angle, and a simple beaded or slightly collared external thickening. Nearly all these jars show evidence of having been fired upside-down; Figures 140.88 and 152.191 had small black glazed 'tygs' stacked in the centre on their upturned base thus causing an unsightly scar.

As in the case of bowls, horizontal loop handles and an internal covering of clear glaze (eg Fig 140.89) are typical of storage jars of the second half of the 17th century, whereas arched lug handles and frequently an external, as well as an internal glaze, are characteristic of the 18th and 19th centuries (Fig 141.92 and 91 respectively). Other 18th-century characteristics are a bifid flanged rim (though confusingly this is also an early 17th-century feature), a constricted or slightly splayed base, and notched decoration on the rim (Fig 140.90 & Fig 141.92). The regularly notched cordon on the rim of the latter is also a decorative feature first seen on a jar from a context of c 1600 (40.86 F76, see above), but which only becomes common in the 18th century. A pair of large 19th-century bread crocks or garden jars (including Fig 141.91) were found together in a pit on Lion Walk. Both are covered with greenish glaze and have rouletted decoration below the rim (square on one, wedges on the other). Identical jars may still be seen in gardens around the town. Large garden jars with rouletted decoration were made at Gestingthorpe, from where these examples may have come (Hills 1944).

Smaller storage jars with a vertical loop handle and a plain flat base (Fig 141.95-97) are an intermediate class between large storage jars and the ubiquitous standard small pad-based jar (Form C4), with which they have more in common date-wise. Two plain storage jars from Stratified Group 17 (Fig 231.23 & 27, c 1625-50) are remarkably similar to rims collected from the kiln-site at Ardleigh. This connection is reinforced by the fact that both jars are highly overfired to a near-stoneware state and are dented and scarred in exactly the same manner as the Ardleigh samples.

Smaller jars and chamberpots (Form C4 and X10: Figs 142.100-107 & 143.108-112)

Standard small jars usually have an S-shaped profile usually ending in a simple thickened or beaded rim, with a pad base, a grooved body sometimes with a rib or cordon on the neck, and a vertical loop handle (Fig 142.101-107). They are glazed on the inside only. Most belong to the second half of the 17th century and particularly to the late 17th and early 18th centuries. These bear a close resemblance to chamberpots and may indeed have served as such, but possibly they had other uses besides. Sooting is rare, but many standard jars have a white deposit internally and the bases are often quite worn. Figure 142.103 is worn on the front opposite the handle, perhaps caused by resting on top of the wall of a stone or brick latrine etc, while emptying the contents.

Chamberpots (Form X10: Fig 143.108-112), are identified by their similarities with 'modern' Staffordshire and 18th-century German Westerwald stoneware examples. Their salient points are a globular, neckless form and often a broad flanged rim. Many chamberpots (unlike standard jars) are glazed externally as well as internally and some are black glazed (Fig 143.109; see also Stratified Group 22, c 1730-40, Fig 246.25). 'Stool pots' are included in an order made in 1550 by Sir William Petre of Ingatestone Hall to Prentice, potter of Stock near Chelmsford (Brears 1971, 184). No 16th- or early 17th-century jars in Colchester have specifically been identified as chamberpots, although there are numerous jars that could have served this function. Globular chamberpots with flanged rims are only common from the late 17th century onwards. Figure 143.112 came from a brick-lined latrine (LWC VF1) containing a range of pottery and clay pipes of c 1740-1840, including seven other chamberpots: one other in Fabric 40, one in Pearlware and five in German Westerwald stoneware.

Pipkins, skillets and cauldrons (Figs 143.113-118, 144.119-124 & 152.190)

Pipkins are very common and standardised in appearance. The most common type encountered (Fig 143.113-117) has a fairly small barrel-shaped body with a grooved shoulder, a flat base with tripod feet, a distinctive hollowed, collared, flanged rim and a diametrically opposed pouring-lip and vertical loop handle (for convenience, shown to right in illustrations). Larger examples of this type are also known (see Stratified Group 17, Fig 231.32). All pipkins have an internal covering of clear glaze and an external covering which ends a little above the base. A single pipkin from Stratified Group 20 (not illustrated) is black glazed. Most examples are sooted from their use as cooking vessels. The most common type already occurs in the second half of the 16th century (not illustrated, Stratified Group 16) and continues with little change into the 18th century. Some of

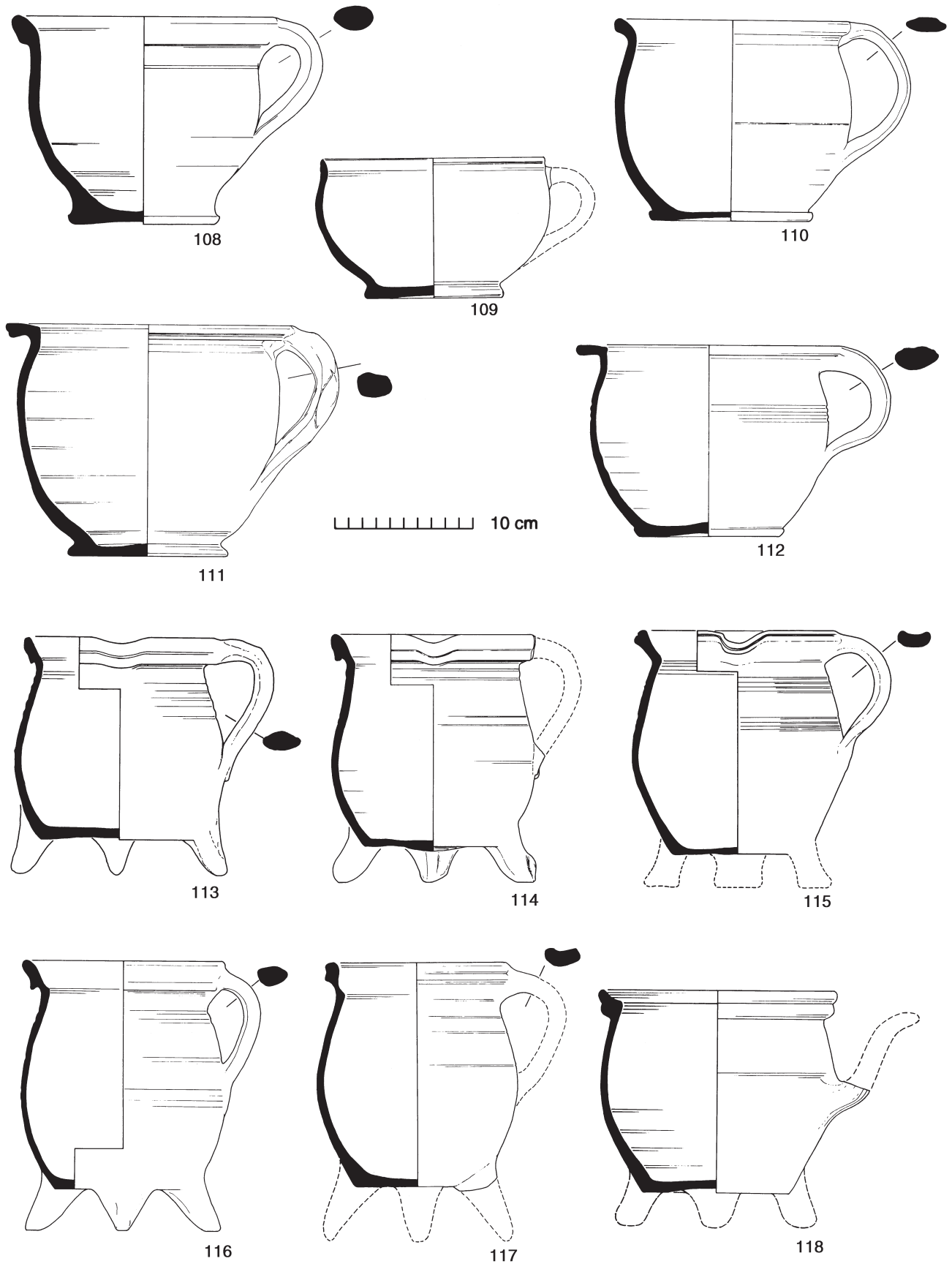

Fig 143 Post-medieval red earthenwares: chamberpots (nos 108-112); tripod pipkins (nos 113-118) — for convenience handles are shown at right-angles to pouring-lip. 1:4.

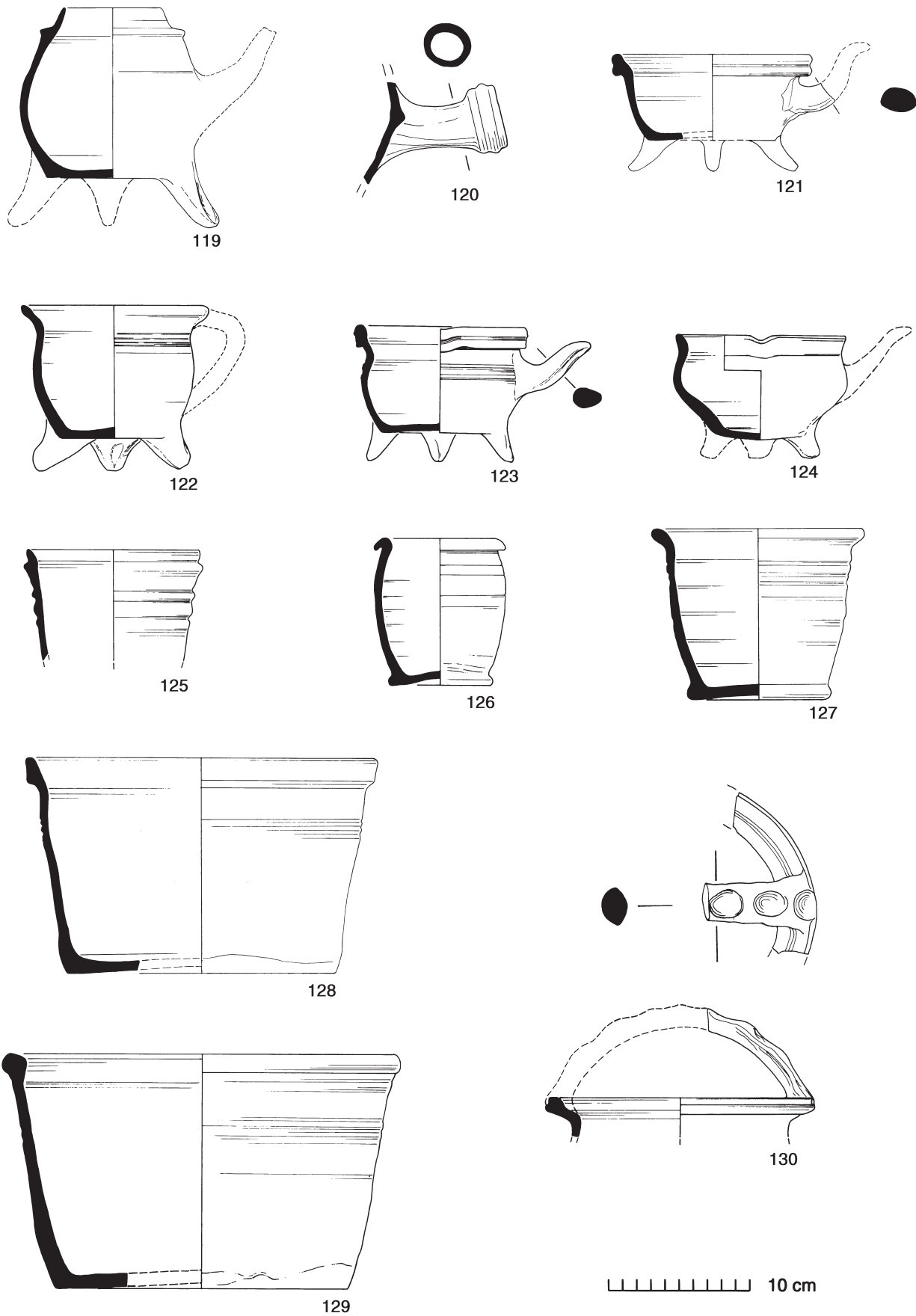

Fig 144 Post-medieval red earthenwares: tripod pipkins (nos 119-120); tripod skillets (nos 121-124); small ?apothecary jars (nos 125-127); conical jars/bowls (nos 128-129); basket-handled jar (no 130). 1:4.

the later examples of this type have heavier, less well-defined rims (Fig 144.122 and Stratified Group 21, Fig 244.87). Figure 143.118 and Figure 244.88 (Stratified Group 21, c 1680-1700), with their bright orange glaze, heavy rim and skillet-type handles, are a distinctive late 17th- and 18th-century type, very probably Gestingthorpe products. One 18th-century globular pipkin sherd has a solid spike handle with a ring of thumb pits securing it to the body (not illustrated). The same technique is found on Border ware pipkins (Pearce 1992, fig 28).

Tripod pipkins with external lid seating are relatively uncommon (Fig 144.119, Stratified Group 20). These are known to occur with hollow tubular handles as Figure 144.120 (Stratified Group 17; also in Stratified Group 18). Both features are known only from early to mid 17th-century contexts and were probably inspired by similar Border Ware pipkins (*ibid*, figs 28.149-54 & 29.165-8).

Skillets with tripod feet (Fig 144.121, 123-124) are much more rare than pipkins, which they closely resemble. The form is either that of a bowl (Fig 144.121) or a shallow jar (Fig 144.123-124). The date range is also identical. Figure 144.124 is from a late 17th-/early 18th-century context and is probably a Gestingthorpe product.

There are only two definite examples of what may be called a cauldron. One of these (Fig 152.190) was one of six vessels buried inside a house at Middleborough in the mid 17th century (*see p 219*). The form is basically that of a large, double-handled pipkin. It is glazed inside with a patch under the base and is heavily sooted from use. A second, wider example occurs in Stratified Group 20 (Fig 237.37, c 1650).

#### Miscellaneous jars

These include a number of small narrow jars that may have served the same function as tin-glazed drug jars (Fig 144.125-127). Figure 144.125 has been intensely overfired and came from a pit on Lion Walk containing a number of other wasters in this fabric. Figure 144.126-127 are glazed inside and out. The former comes from Stratified Group 17 (c 1625-50) and the latter may be derived from a possible apothecary's dump (Stratified Group 20). The two conical bowl-shaped jars Figure 144.128-129 both come from late 17th-century contexts and are glazed inside and out. Bucket-handled jars (Form X18; Fig 144.130) are known from only two or three examples. A possible example occurs in Stratified Group 20 (Fig 237.41), and another example has a notched rim suggesting a late 17th- or 18th-century date. This form, which may be Dutch-inspired, has been noted in a number of post-medieval red-ware industries from Fulmodeston in Norfolk (Wade-Martins 1983, fig 22.157) to Canterbury in Kent (*pers obs*).

#### Sugar-refining jars (Fig 131, centre back)

Although none was found on the excavations, there are three Fabric 40 syrup jars in Colchester Museum (not illustrated, form as Allan 1984, fig 130.2901). These are unaccessioned and nothing is known of when and from where they were acquired. Two are kiln wasters; one is so badly overfired that it has flawed and split open rendering it entirely useless. This strongly suggests that they must come from a nearby kiln-site, although the former curator does not believe they represent the missing collection of wasters from the Ardleigh kiln (D T-D Clarke, *pers comm*).

There is no published account of sugar-making in Colchester, but in the reign of James I it was customary for the town to present sugar-loaves to persons of rank from whom favours were sought (Morant 1748, 1, 53).

#### Jugs (Fig 145.131-137)

These are relatively uncommon and generally rather similar in appearance. There are two common types, although the distinction is not a sharp one: jugs with a simple, slack S-shaped profile (Fig 145.133-134, 137 & Fig 150.188), and jugs with a bulbous body and a distinct angle between body and neck, often high shouldered with a cylindrical neck (Fig 145.131-132, 136). The latter type is slightly commoner and later jugs tend to be of this type, particularly those with cylindrical necks. Figure 145.137, however, is not of this type and yet comes from a late 17th-century context. The latest Fabric 40 jugs, from late 18th-century contexts on the Angel Yard site, have globular bodies and finely ribbed cylindrical necks clearly inspired by German Westerwald stoneware jugs.

The earliest Fabric 40 jugs in Colchester are in fine Central Essex-type fabric. Only two examples are known and these come from early 16th-century contexts (Fig 226.10 with handle graffito; Stratified Group 13, c 1500-25). The other example is a plain jug rim with pouring-lip and a glaze bib (not illustrated, LWC KF64). Due to the difficulty of recognising well-dated contexts of the later 16th century, this period is represented by a single jug with a plain ribbed rim and a glaze bib (not illustrated; Stratified Group 16).

Nearly all jugs have a plain, slightly everted rim with a lower external rib or cordon giving a collared look, grooves on the upper body, and often a rib or cordon at the base of the neck. Pad bases are the only type which occurs, although one or two dubious jugs have flat bases. Glaze is normally confined to a broad 'bib' of clear glaze below the pouring-lip. Around one-tenth of all jugs are black glazed (Fig 145.132, 139 & Fig 242.60, Stratified Group 21). Figure 145.136 has an unusual mottled, iron-streaked brown glaze and is probably 18th century.

Figure 145.132 and Figure 242.60 (Stratified Group 21, c 1680-1700), with their black glaze, pad bases and lightly faceted handles, share several features with a black glazed vessel in Colchester Museum, known as the "Braintree ringers' jar" (actually a two-handled jug), and which bears an inscription ending 'made at Stock 1685' (Cunningham 1985, fig 51). It is very likely, therefore, that these jugs also come from Stock near Chelmsford, and that most of Colchester's black glazed wares also come from here. Tall, sub-biconical jugs with a golden-orange glaze were made at Gestingthorpe. Figure 242.58-59 (Stratified Group 21) resemble a number of Gestingthorpe jugs in Colchester Museum.

Among the more curious ?jug fragments is a waster, Figure 145.138 (Stratified Group 18, c 1625-50), whose handle was broken off before or during firing allowing the scar to become covered in glaze. Figure 145.139, with its all over black glaze, pedestal base and incised vertical decoration, is quite unique (if it is a jug at all). It could be a copy of a Border ware mug, some of which are decorated in a very similar fashion (Pearce 1992, fig 36.272-3), or possibly copying German stoneware jugs (*cf* Reineking von Bock 1971, no 481 ff). Figure 145.135, from a late 17th-century context, has an incised graffito symbol both on the body



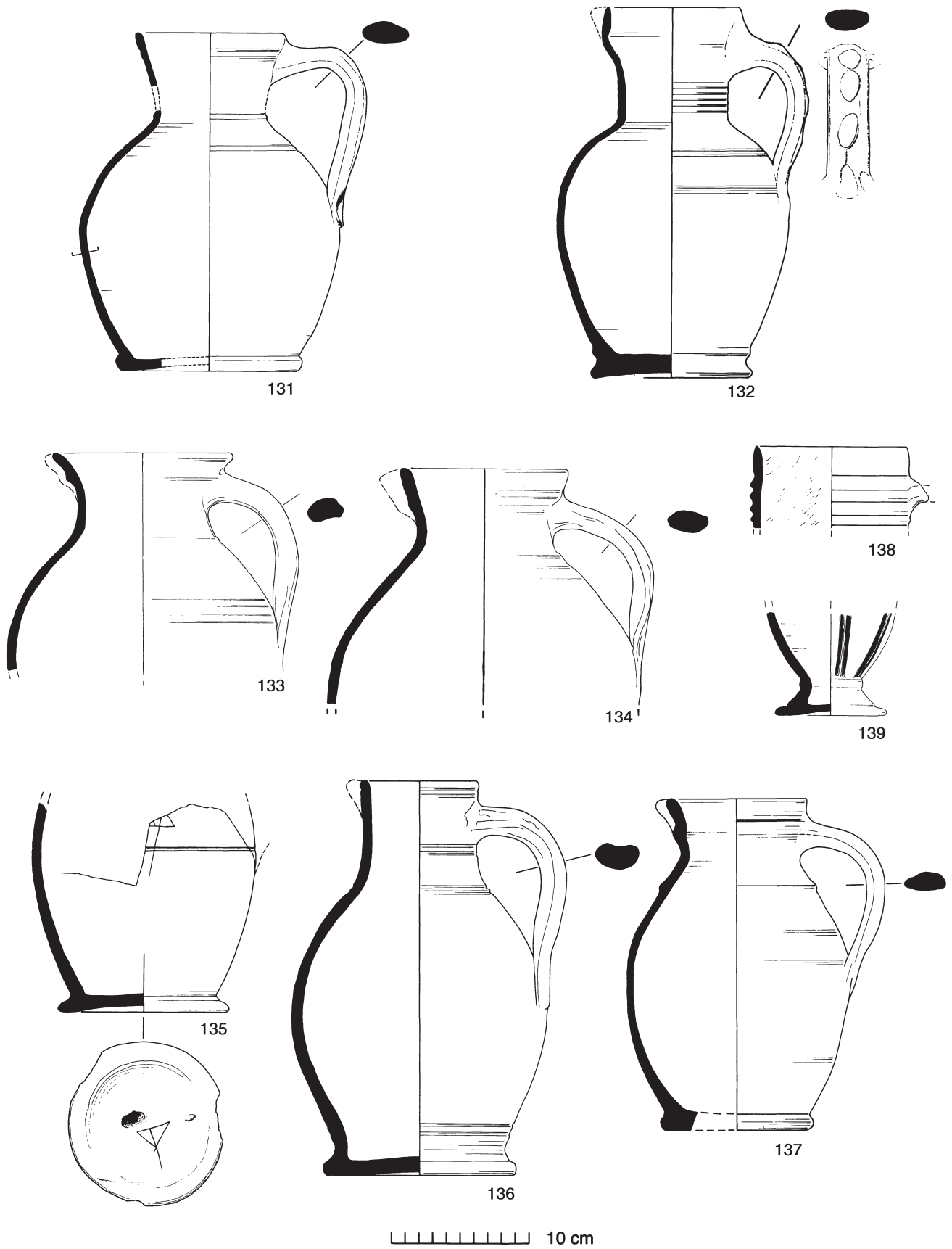

Fig 145 Post-medieval red earthenwares: jugs (nos 131-139; no 135 with graffiti). 1:4.

and under the base. Such graffiti are usually identified as potter's marks.

#### Cups, mugs and tygs (Fig 146.140-157)

Eighty per cent of all drinking vessels in Fabric 40 are black glazed, the remainder being either clear or lustrous brown glazed. Several forms occur, the commonest of these being the conical mug, most commonly with just a single handle but not infrequently with a pair of handles set close together (Fig 146.140-146). At Chelmsford, there are clear glazed, segmented, conical mugs as Figure 146.140, simpler mugs as Figure 146.146, and black glazed mugs as Figure 146.143, all occurring in contexts dated to *c* 1560-90 (Cunningham 1985, fig 45.40, 39 & 37). Similarly, Stratified Group 16 (*c* 1550-1600) produced the segmented mug Figure 146.140 as well as black glazed mugs (as Fig 146.143) and a barrel-shaped clear glazed mug (as Fig 146.155). Figure 146.146 is from a context of *c* 1600 (LWC KF15, see p 232). The black glazed conical type continues with little change into the early 18th century.

Two or three conical mugs from late 17th-century contexts have incised decoration (Fig 146.141). One sherd has a fragmentary band of inscription (including the letters '...GV...'). Another fragment comes from a highly decorated, probably multi-handled mug, with a beaded strip set against the wall behind the handle and incised lattice decoration below the handle (not illustrated). Similar incised conical mugs occur at a Border ware pottery production site at Cove, Hampshire where they are dated *c* 1625-50 (Haslam 1975, fig 7, 67-76). A similar highly decorated conical mug or posset pot at Chelmsford also has multiple handles, and applied and incised decoration (Cunningham 1985, fig 9.64). The latter is from a context of *c* 1650-1700 and may have been made at Stock or Harlow (*ibid*, 71).

Next in importance are a number of various globular, barrel-shaped and straight-sided 'tankards'. The small globular-bodied mugs (Fig 146.150-153) are always black glazed and come from contexts of the second half of and, in particular, the late 17th century. At least six such cups occur in Stratified Group 21 (*c* 1680-1700), which may have been a tavern dump. The form of these mugs is almost identical to type 1 Border ware mugs which in London come from mid to late 17th-century contexts (Pearce 1992, 27-8, figs 35.263-70 & 36.271-3). Also black glazed, Figure 146.152 is similar in form to the smaller mugs but could be considered a drinking jug on account of its size. The form and the handle scroll owe something both to German stone-ware jugs and to tin-glazed pottery. Clear glazed barrel-shaped tankards, as mentioned above, occur from the late 16th century and also have Border ware parallels (*ibid*, fig 36.274-6). Figure 146.155 came from a pit containing a coin of 1625-44. Figure 146.154 is black glazed and possibly 18th century, while Figure 146.156 is brown glazed; both forms are reminiscent of pewter tankards.

Small, black-glazed carinated cups (Fig 146.147-149) are known from mid 17th-century contexts, in particular from the Sheepen siege fort of 1648 (Fig 150.189, see pp 218-19), though Figure 146.147 is from a late 17th- or early 18th-century context. The bipartite, three-handled cup or posset pot (Fig 146.157) is one of only two from the excavations (Stratified Group 17, *c* 1625-50).

#### Miscellaneous forms (Form X)

##### Chafing dishes (Fig 147.158-162)

These occur from the second half of the 16th century (Fig 147.159; Stratified Group 16) until at least the late 17th century (Fig 243.82-83; Stratified Group 21). There are several minor variations of rim, base and spur form with no obvious chronological difference. Glaze is largely confined to the inside but sometimes covers the outside of the bowl as well. Bases with inserted thumbed bowls (Fig 147.162) occur in roughly equal proportions to those with cut-out pedestal bases (Fig 147.161); both illustrated examples are from late 17th- or early 18th-century contexts. Folded or pinched strap spurs occur on a small number of chafing-dish rims, both of early and late 17th-century date (not illustrated). Examples with slots pierced through the vessel wall are uncommon (Fig 147.158). The extensive glaze coverage on the latter suggests a late 17th-century date. The most unusual example (Fig 147.160), from a mid 17th-century context, is clear glazed all over, and is unusual for its small size and corrugated profile. There is no trace of spurs on the rim but only a fraction of this survives. The fabric is rather coarse and it could conceivably be a late 16th-century survival of the Colchester-type (Fabric 21A) fabric, although Fabric 40 is the more likely identification.

##### Condiments (Fig 147.163-164)

These consist of two or three bowls luted together, and are represented by around a dozen examples ranging from the second half of the 16th century (Stratified Group 16, not illustrated), to the late 17th century. Most are glazed internally. Figure 147.163 is in a fine unglazed Central Essex-type fabric and could be earlier 16th century, but was unstratified.

##### Costrels (Fig 147.165-167)

About sixteen individual costrels came from the excavations. All but one are basically small and bottle-shaped with a pair of pierced lugs on either side of the neck, a pad base, and flattened on one or both sides (Fig 147.165-166). All are covered with a clear, often greenish, external glaze. One fragmentary example is much larger and more globular than the others, while another has an unusual, heavily ribbed or annular tubular neck (Stratified Group 18, *c* 1625-50; not illustrated). Costrels of this type occur in Colchester contexts spanning the 17th, and possibly the early 18th, centuries. Figure 147.165 is from a pit context of *c* 1660 (with coin of 1636-44 and clay pipes of 1640-60 and 1640-80). The other type of costrel, with vertical loop handle (Fig 147.167), is unique. The upper two-thirds are covered with a clear glaze and the base was so badly flawed during manufacture that it was probably useless except as a water sprinkler. A large, partially-glazed, shallow barrel-shaped costrel with a short tubular neck, bead rim and a pair of transverse S-shaped handles is the only other major departure from the general type of costrel found in Colchester. This was found with an exceptionally large dump of Fabric 40 and other vessels in Head Street in 1935, including tin-glazed pottery of *c* 1680; much of this is now deposited in Colchester Museum (CMR 1935, fig 9).

##### Lids (Fig 147.168-170)

These are quite common and occur throughout the life span

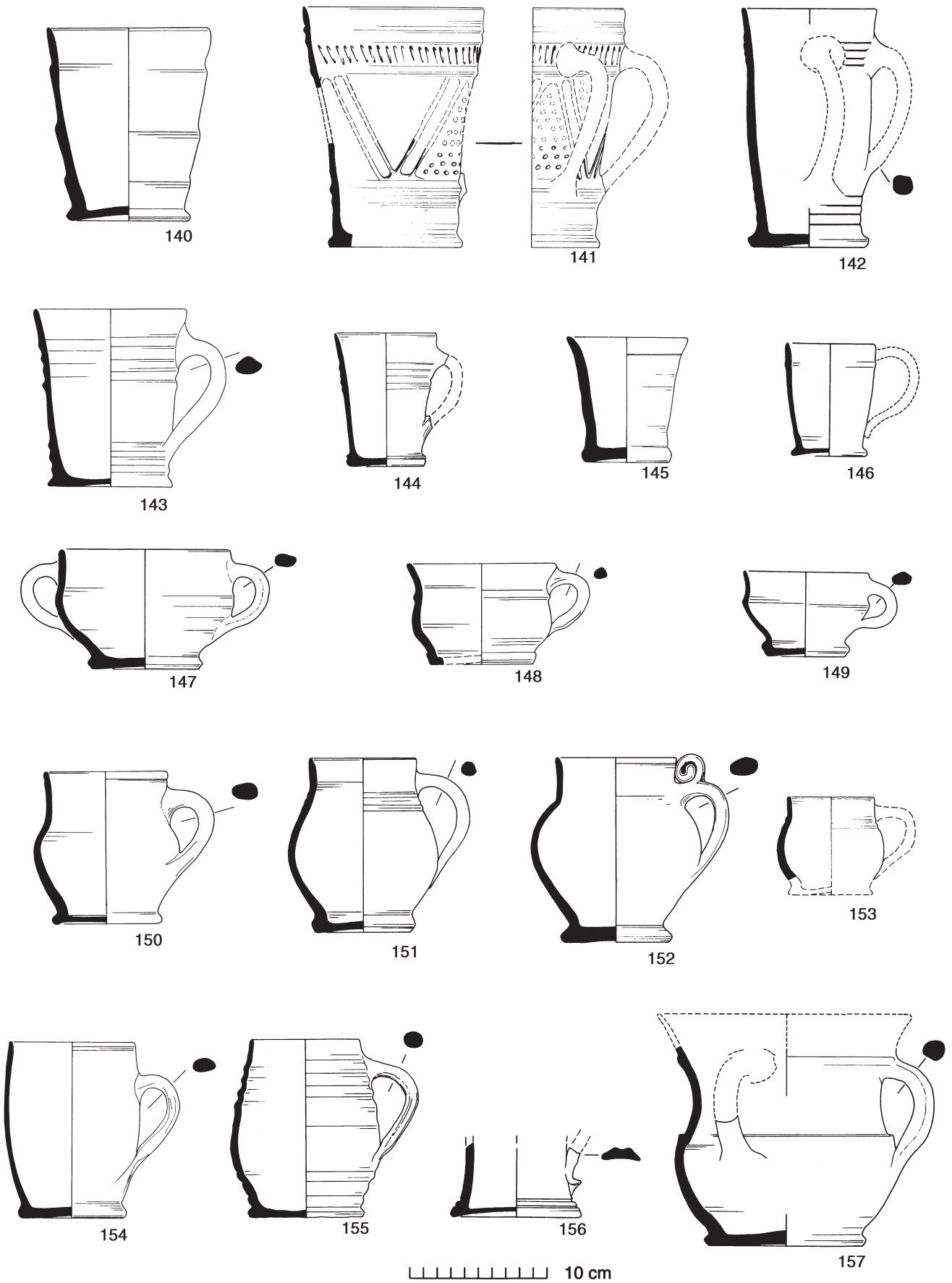

Fig 146 Post-medieval red earthenwares: cups, mugs and tygs (nos 140-157). 1:4.

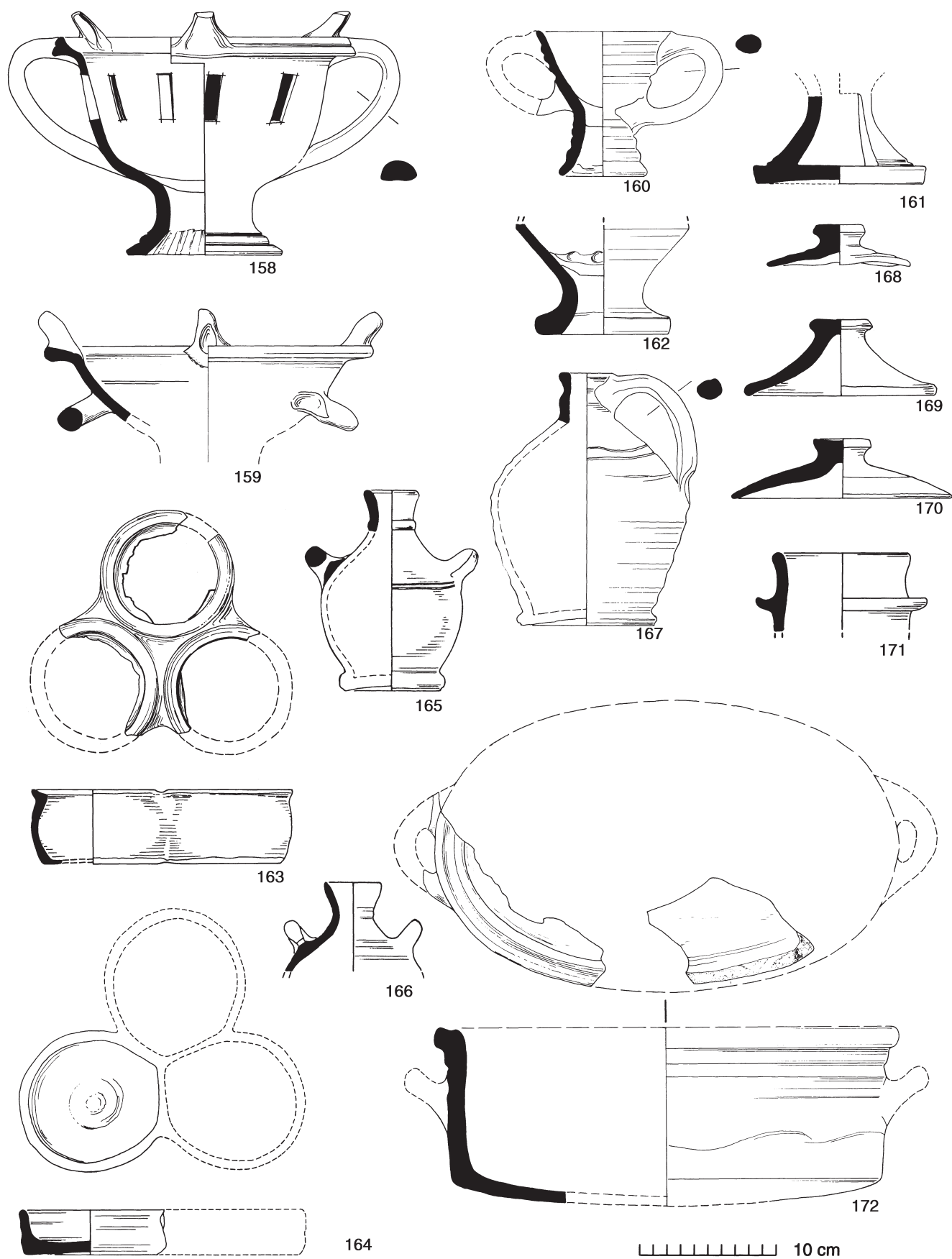

Fig 147 Post-medieval red earthenwares: miscellaneous forms — chafing dishes (nos 158-162); condiments (nos 163-164); costrels (nos 165-167); lids (nos 168-170); water-pipe (no 171); oval 'casserole' or 'brining trough' (no 172). 1:4.

of Fabric 40, all with plain rims and discoid knobs. The diameter range is 105-190 mm. Several examples have a splash of glaze either inside or outside. Figure 147.168 is badly warped, and a further example from a late 18th-century context (MID CF136) is a kiln waster with glaze across its broken edge. One example had scored radial lines underside.

#### Water pipes (Fig 147.171)

Two or three of these were found. The illustrated example is from Stratified Group 21, c 1680-1700. Some have glaze splashes outside.

#### Oval 'casseroles' or 'brining troughs' (Fig 147.172)

Only one of these came from the 1971-85 excavations. This has an all over golden-orange glaze and it is probably a Gestingthorpe product of the 18th century (though unstratified). A second example from an early 19th-century context at Angel Yard (40.86 F230) has an applied rosette of thumbed clay. There is a third example in Colchester Museum. These could have served much the same function as a modern casserole dish or they may have been used for pickling joints of meat. Shaped vessels for pickling joints of pork are known to have been among the products of the Gestingthorpe works (Hills 1944). Similar vessels, sometimes much longer and trough-shaped, occur over much of the country in the 18th and 19th centuries (eg Jennings 1981, fig 80.1347).

#### Dripping pans (Fig 148.173-176)

These are relatively common; they are mostly slab-built and glazed inside and most also with evidence of sooting underside. On Figure 148.176 the base and sides appear to have been made separately and then luted together. Figure 148.174 (associated with a coin of 1699-1701 and clay tobacco pipe of 1680-1710) appears to have been wheel-thrown as a wide dish and then compressed into an oval shape, necessitating the substitution of the original floor for a luted-on slab-built replacement. The whole vessel was then covered with glaze. The only discernible dripping-pan form is oval or sub-rectangular with a pair of skillet-handles on one side and a pouring-lip at one end (Fig 148.173-176). Rims tend to be slightly more complex than their medieval predecessors and are often flanged. Figure 148.175 is from a mid 16th-century context and its fabric is somewhat transitional between Fabrics 21 and 40. The form occurs well into the 18th century.

#### Pierced vessels

Many of these are recognisable as ordinary Fabric 40 forms, differing only in their adaption to some specialised function. Others were specifically formed to suit their particular function, ie the following categories.

#### Firepots (Fig 148.177)

Figure 148.177 is one of four virtually identical vessels from the excavations. All these examples have the same collared rim, grooved shoulder and one or two bands of neatly pierced holes. The upper half only is covered with a clear glaze both inside and outside. Only Figure 148.177 is slightly sooted inside, but on all examples the underside of the base is quite worn. These have been described as firepots (Brears 1971, 27-9) on the basis of their similarity

to firepots shown in 16th- and 17th-century Flemish and Dutch paintings, in particular Vermeer's 'Kitchen maid' of c 1660. Such pots, containing hot embers and kept inside a perforated wooden case, were used by women lace-makers who would drape their long skirts over the pots to keep warm during their long hours of toil. Pots of this type are particularly associated with immigrant textile workers, in particular the Dutch. Colchester has no particular history of lace making but did, however, have a flourishing textile industry largely in the control of Dutch immigrants (see above p 19).

Of the three stratified examples from the excavations, the illustrated example and an identical vessel came from the same late 17th- or early 18th-century pit (with tin-glazed plates of c 1680+). The other stratified example came from a pit (LWC GF26) containing thirteen clay tobacco pipes, the latest of which was c 1660-80. Both pits contained a very similar range of pottery to Stratified Group 21 (c 1680-1700). English examples of firepots are said to occur in early 17th-century contexts and one such example cited in Brears (p 28) is actually from an earlier Colchester excavation (Hurst 1961a, fig 23). Dating for this particular context was provided by a Werra slipware dish and some tin-glazed fragments. The Fabric 40 from the same pit, particularly the dishes, could suggest a date closer to the middle of the 17th century.

If these vessels really were used as a kind of personal stove, associated in particular with Dutch immigrant communities, then it is surprising that so far only five (mid to late 17th-century) examples have turned up in a town that boasted a large population of Dutch textile workers, most of whom had settled here in the 16th and early 17th centuries. With one or two possible Dutch exceptions, firepots do not occur in any other fabric in the town so one must suppose that ordinary non-pierced pots could have served much the same function.

#### Strainers or cheese presses (Fig 148.178-180)

These have pierced bases and two examples (Fig 148.179-180) have one or two perforations through the rim. Figure 148.178 (Stratified Group 21, c 1680-1700) is a standard local dish form. Figure 148.179 (mid 17th century) shows strong Dutch influence. These vessels could have served as strainers or colanders or perhaps to drain off excess liquid during cheese-making. While a single perforation through the rim might simply have allowed the vessel to be hung up on a hook, two opposite pairs of perforations may have allowed suspension of the vessel for the slow-draining of certain foodstuffs.

#### Flowerpots (Fig 149.181-182)

This category does not include the ubiquitous 19th-/20th-century flowerpot (Fabric 51B). Easily recognisable as a flowerpot, Figure 149.181 (Stratified Group 22, c 1730-40) has an unglazed porous fabric. Less easily categorised are a number of large jars with perforations through the rim and base (Fig 149.182). These are mostly unglazed except for splashes under the rim and base, although fragments with internal glaze are not unknown. A very similar jar described as a 'strainer' (though apparently with an unpierced rim) came from a kiln at Woolwich which went out of production towards the end of the period c 1660-80 (Pryor & Blockley 1978, fig 13.68). Similar late medieval vessels from Utrecht, Holland are described as plant or flowerpots (Bruijn 1979, fig 35.6-8); an alternative function, however, cannot be ruled out. Figure 149.182 is one of three near-identical examples

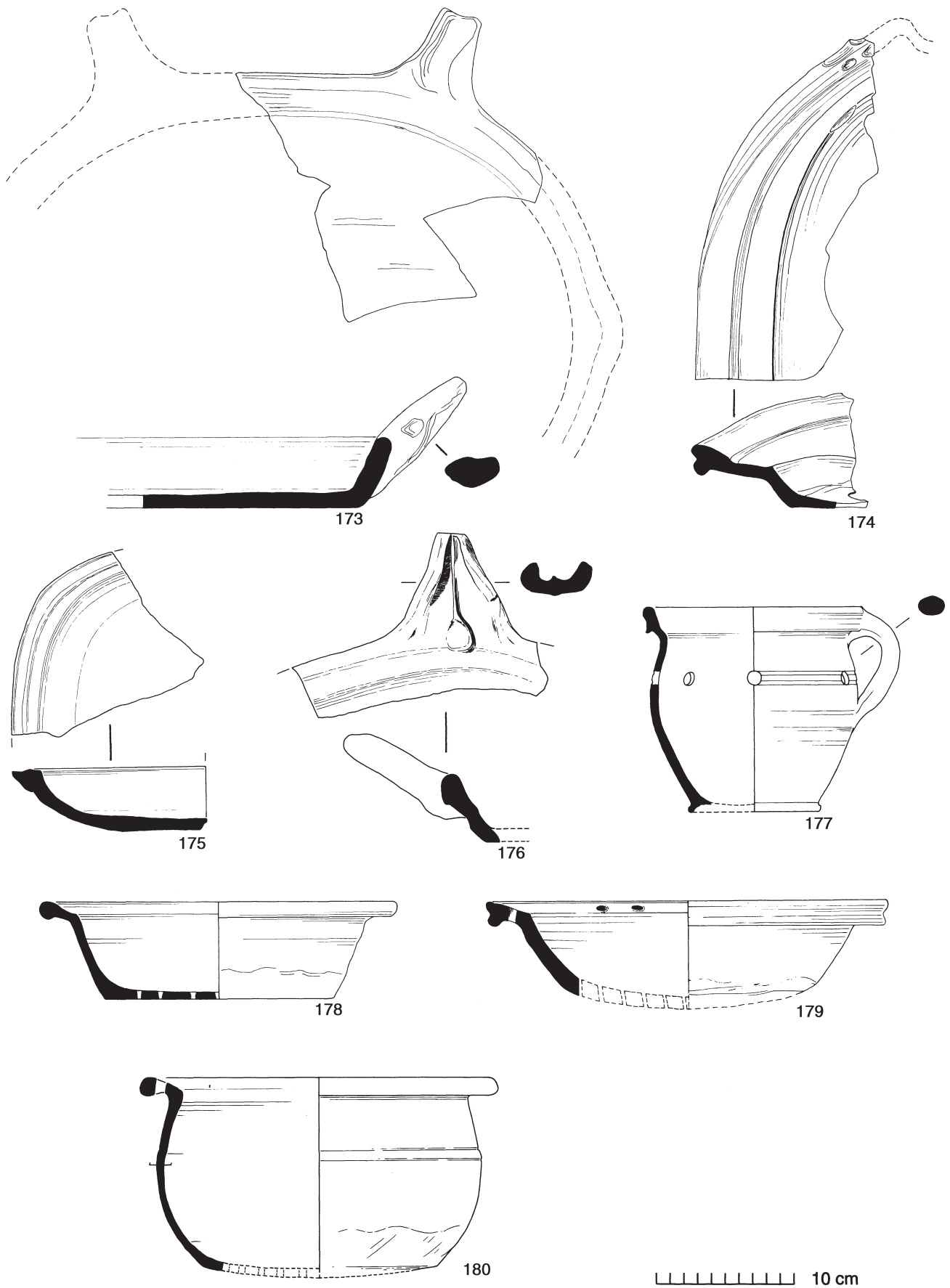

Fig 148 Post-medieval red earthenwares: miscellaneous forms — dripping pans (nos 173-176); firepot (no 177); strainers or cheese presses (nos 178-180). 1:4.

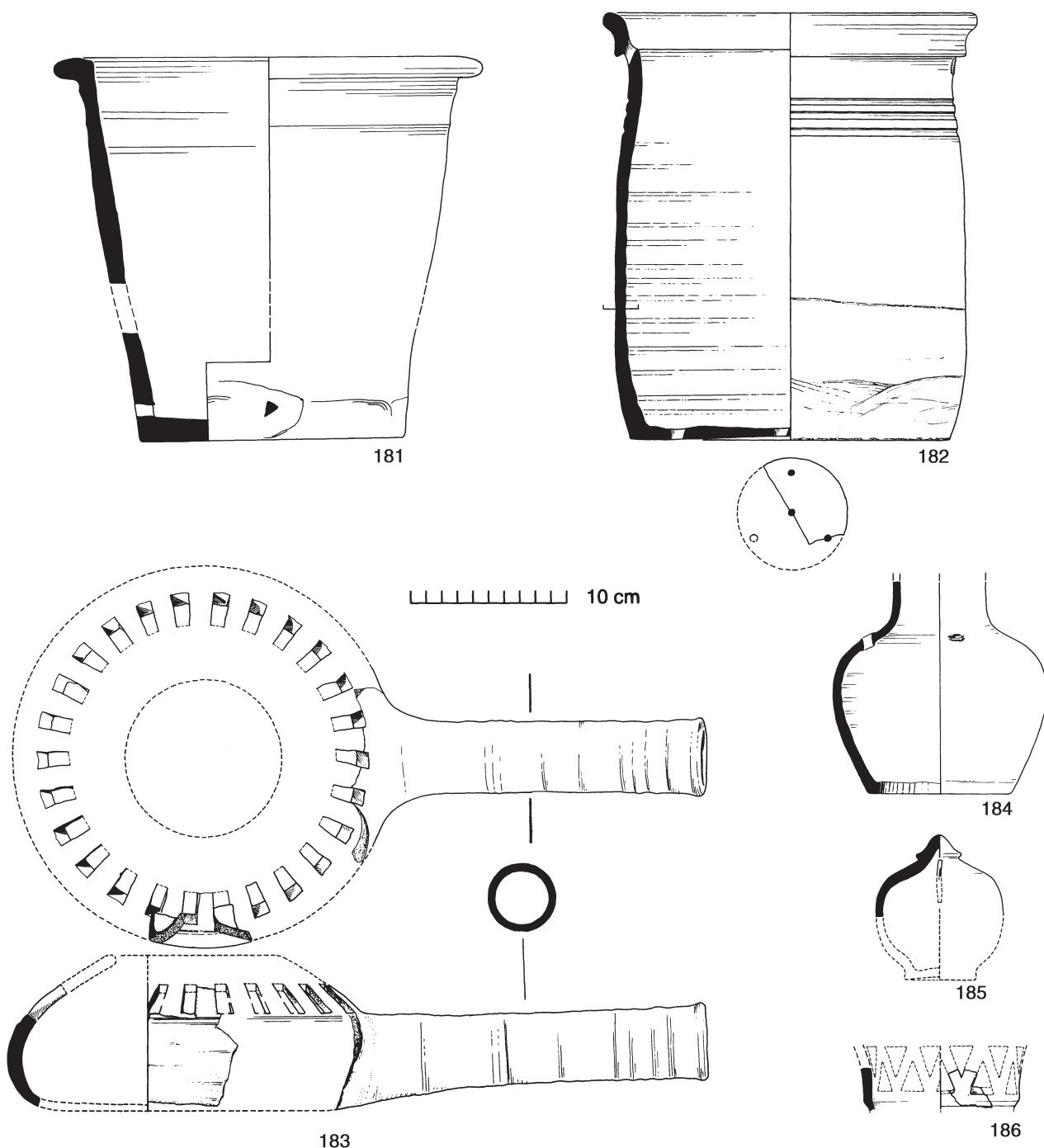

Fig 149 Post-medieval red earthenwares: miscellaneous forms — flowerpots (nos 181-182); bed-warming pan (no 183); bird pot (no 184); moneybox (no 185); ?puzzle-jug or pomander (no 186). 1:4.

possibly derived from a (?tile) kiln in Trinity Street (see above, pp 10 & 191). None shows any sign of use and all three display the same defective manufacture (spalling, splitting along lines of weakness); one large fragment is grey and reduced. This suggests that they are wasters. Their fabric suggests a late 17th- or 18th-century date, but similar pierced rims are known from several early and mid 17th-century contexts (Fig 237.39; Stratified Group 20, c 1650).

Bed-warming pan (Fig 149.183)

A single example of this form was recovered. This had a wide gently domed body pierced with rectangular slots, to which a long tubular handle was affixed but which does not open into the body of the vessel. The whole exterior is covered with a clear glaze. Shape suggests that this was the ceramic equivalent of a brass bed-warming pan. Two very similar examples are known from the pottery site at Fulmodeston, Norfolk (Wade-Martins 1983, fig 15.87-8).

This example came from a general site-clearance layer and is therefore unstratified. However, there is little doubt that it derives from a complex of 17th-century pits on this site, most probably LWC CF7, which has several cross-joins with vessels from the clearance layer. This pit contained mid to late 17th-century pottery, clay pipes and coins, but also some slight modern contamination.

**Bird pot (Fig 149.184)**

One example of this form has been identified (Stephen Moorhouse, pers comm). It has a fine, unglazed fabric. Before firing, the circular base was cut away and a single perforation made through the shoulder of the pot. The rim is unfortunately missing, but there was normally a perforated nib on the neck through which a twig perch was threaded, entering the body via the shoulder perforation. Bird pots were usually attached by a loop handle to a branch of a tree or under the eaves of a house. The idea of encouraging sparrows or similar troublesome birds to nest in these pots appears to have been a form of pest control, a bounty being paid by churchwardens for so many hundred sparrow heads handed over. They also supplied a readily available supply of filling for sparrow pie (Barnard 1948).

Most English examples date from the 16th and 17th centuries although they continued to be made in some rural areas right up to the present century (*ibid*, 51 note 2). Bird pots have a longer history of use on the Continent where they are depicted in a number of Flemish and Dutch paintings. They are particularly well known from Holland (eg Hurst *et al* 1986, fig 65.224). The Colchester example came from an 18th- or 19th-century pit which also contained a large amount of residual 17th-century and earlier material. English bird pots are first mentioned in the accounts of Sir William Petre of Ingatestone Hall, Essex. An order in 1549-50 to a 'fellow of Stocke' (Stock near Chelmsford) includes '24 pottes for sparoweis to breede ine, 12d', and an order in

1550 to 'Prentis ye potter of Stocke', includes '4 doz. D pottes for sparowes and starlynges and for nayles to hange them by 2s. 2d' (Barnard 1948, 55).

**Moneybox (Fig 149.185)**

There is only one certain moneybox in Fabric 40. It is glazed all over externally and comes from an early 17th-century ash pit.

**Puzzle jug (Fig 149.186)**

Figure 149.186 (Stratified Group 20, c 1650), is part of a black glazed vessel pierced with opposing triangular slots. It may be from a puzzle jug or a pomander.

**A group of vessels from a Civil War fort at Sheepen, Colchester**

[Fig 150.187-189]

In 1931, excavations on Iron Age and Roman features at Sheepen Farm, Sheepen Hill (otherwise known as the 'Hilly Fields'), came across the remains of a siege fort of the English Civil War (Hawkes & Hull 1947, pl cx). No structures were found and, not surprisingly, the fort was not thoroughly investigated and no detailed account was kept or published. The following year, however, a description and photograph of some of the recovered 'relics of the Siege of Colchester' was published (*CMR* 1932, 45, pl 14). Among the 'relics' (Clarke 1975, 9) was a typical Parliamentarian 'Lobster-cage' helmet, a cuirass, stirrups, spurs, musket balls, leaden powder canisters, keys, clay tobacco pipes and three virtually complete pottery vessels. One suspects there may have been more pottery, but its broken condition may have deterred its collection.

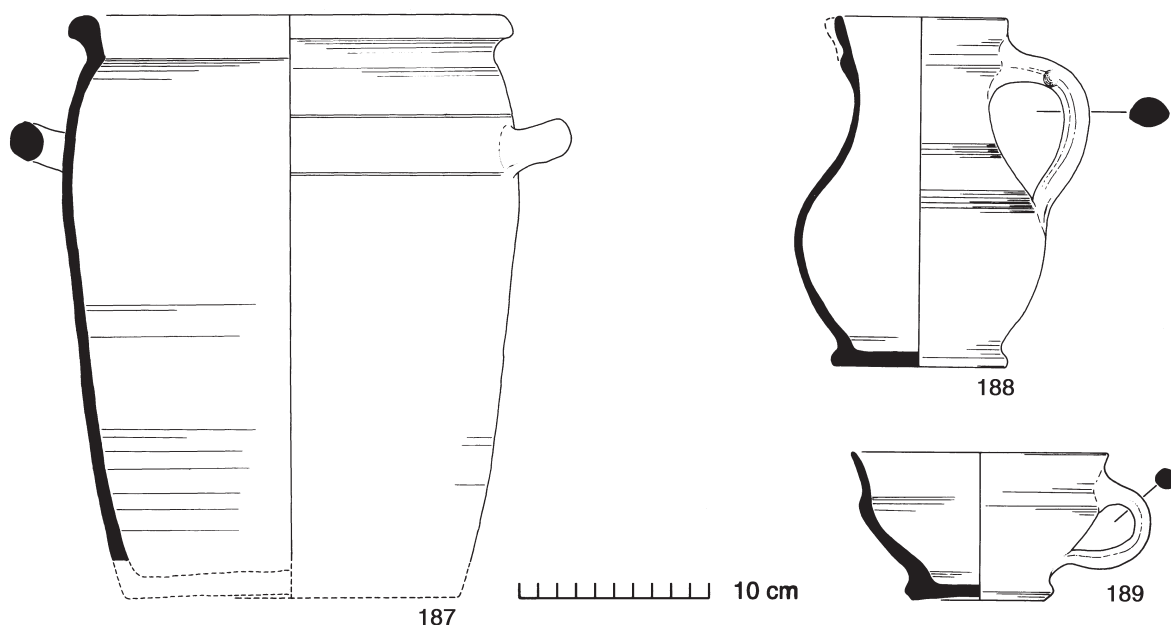

Fig 150 Post-medieval red earthenwares: pottery group from Sheepen Farm Civil War siege fort, June-August 1648 (nos 187-189). 1:4.



From its position on Sheepen Hill, lying to the west of the town wall, it was possible to identify the fort as the redoubt to the south of Colonel Ewer's fort (Crummy 1999), one of the Parliamentarian earthworks thrown up around the town during the siege of Colchester (see *VCH*, 9, 74 & Crummy 1999 for plan of forts). The siege began on the 14th June and lasted until 28th August, 1648; the forts, being simple stockaded earthen structures, were afterwards abandoned. The pottery recovered is therefore of considerable interest as the closest datable post-medieval group from Colchester. Although the conditions of its recovery will never be precisely known, there is no doubt that the pottery came from the same spot as the military equipment (we are grateful to the former curator Dr D T-D Clarke for this information which he had from the previous curator and excavator of this site, Mr Rex Hull). There was no recorded subsequent use of this site except, perhaps, for agricultural purposes.

All three vessels are in Fabric 40. The large storage jar (Fig 150.187) has a highly fired fine orange biscuit fabric with a purplish-brown bloom external. A dark greenish-brown glaze covers the internal surface to within 5-6 cm of the rim. A large splash of glaze below one handle suggests the jar was fired upside-down. The rim has kiln scars and was dented during stacking.

The jug (Fig 150.188) has a well-fired, bright orange biscuit fabric with well-preserved fingerprints outside. A bib of greenish-brown glaze extends from pouring-lip to base and covers the underside which bears a kiln scar, these suggest the vessel may have been fired upside-down. A purplish-brown bloom covers the unglazed areas.

Figure 150.189 is a small carinated cup or bowl. It has a sandy orange biscuit fabric which may have been covered with a dark orange-brown wash before glazing. The glaze is a streaky greenish-black, covering the inside and outside, stopping irregularly above the pad base and only partially covering the handle. Overfiring has caused lustrous and iridescent areas in the glaze, particularly inside where it is thickly pooled on the floor and has become embedded with small wasted chips of pottery.

All three vessels are perfectly compatible with a roughly mid 17th-century date as testified by similar vessels from excavations in the town. Storage jars of this kind, however, could date from any time in the 17th and the early 18th centuries but are particularly common in the second half of the 17th century. The relatively small size and marked pear-shaped form of the jug is not exactly paralleled in the excavations where whole jug profiles are rare. Its general shape and rim form, however, are standard. Carinated black glazed cups are known principally from mid 17th-century contexts.

### Buried pots at Middleborough

[Figs 151 & 152.190-192]

In 1978, two adjoining buildings (Buildings 75 & 76), dating from the medieval period, were investigated at Middleborough just outside the North Gate of the town wall. Building 76 survived until 1978 as the New Market Tavern. This has been mentioned earlier in connection with a buried late 14th- or early 15th-century Colchester-type ware baluster jug (see p 129). Building 75, with which we are presently concerned, stood until c 1862 when it was demolished to make way for the new Cattle Market. A detailed

account of these buildings has already been published (*CAR* 3, 189-209). There is no evidence that Building 75 was ever anything more than an ordinary dwelling.

Excavations in the house and its backyard uncovered the remains of six pottery vessels (all Fabric 40) which had all deliberately been buried in an upright position. The distribution of these pots (Fig 151), both inside and outside the house, shows no clear pattern except that none occurs in the medieval hall which was presumably the main living-room. However, one pot (F140) does occur in what were the south service rooms, but which were converted into another living room probably in the 17th century. Whether the pot was buried before or after this conversion is unknown. With only one possible exception, then, all the pots were located either in the ancillary service rooms of the house or outside in the yard. A description of the pots and the circumstances of their discovery is given below:

*Pot F104* (Fig 152.191). Large, almost complete storage jar, glazed internally. This vessel is a 'second' or a waster. The fabric is overfired and brittle and has cracked during firing along lines of weakness at the base and shoulder. It was fired upside-down and a smaller drinking vessel stacked on its base causing a bad scar. It is worn internally. Near the top of its soil fill the pot contained a mid 17th-century token of Richard Bush (*CAR* 4, 81). The pot was positioned just inside the yard, next to the external wall of the house at the external angle where the wall and a tile drain meet. The rim of the pot appears to have been flush with the tile drain (F144/173), which stops a little short of the pot. It may have stood to one side of a doorway opening out into the yard.

*Pot F112* (Fig 152.190). Two-handled tripod cauldron, glazed internally. Sooted outside, heavily worn inside, much abraded at broken edges. One leg broken in half, presumably before burial. This pot was set in a pit adjacent to a post. The pot was set in the centre of a brick floor (F105) in the east-west corridor of the north wing. The rim of the pot was flush with the brick floor which appeared to slope downwards, slightly, towards its mouth.

*Pot F140* (not illustrated). Base and lower body of storage jar identical to F104 (Fig 152.191). Glazed internally. Much abraded externally and worn internally. Set in the ground a short distance south-east of a fireplace in the former southern service room.

*Pot F242* (Fig 152.192). Large, virtually complete storage jar. Rim missing and break heavily abraded. Sagging base. A pair of frilled ledge handles at shoulder level. Covered inside, outside and underside with a black glaze. Possibly late 16th or early 17th century, although it could have been old when buried. Heavily worn/abraded internally, especially centre base. The soil fill was analysed by Peter Murphy and consisted of a dark greyish-brown loam with brick/tile fragments, a small quantity of charcoal, two seeds of *Sambucus nigra* (elder), bone and cockle-shell fragments. The pot was located in the north wing of the house in a pit adjacent to the main north wall, and it seems very likely that the rim (or perhaps the broken edge) of the pot was once flush with a brick floor (F103), although the floor is too poorly preserved to be certain.

*Pot F271* (not illustrated). Flat base of storage-jar type but pierced by a circle of five perforations. Glazed inside and outside. Abraded. The soil fill consisted of brown sand with brick/tile fragments, coal, small charcoal fragments and one seed of *Sambucus nigra*. Located outside north-west corner of north wing in outside yard. The pot was sealed and damaged by the 19th-century rebuilding of an adjacent older soakaway (F266).

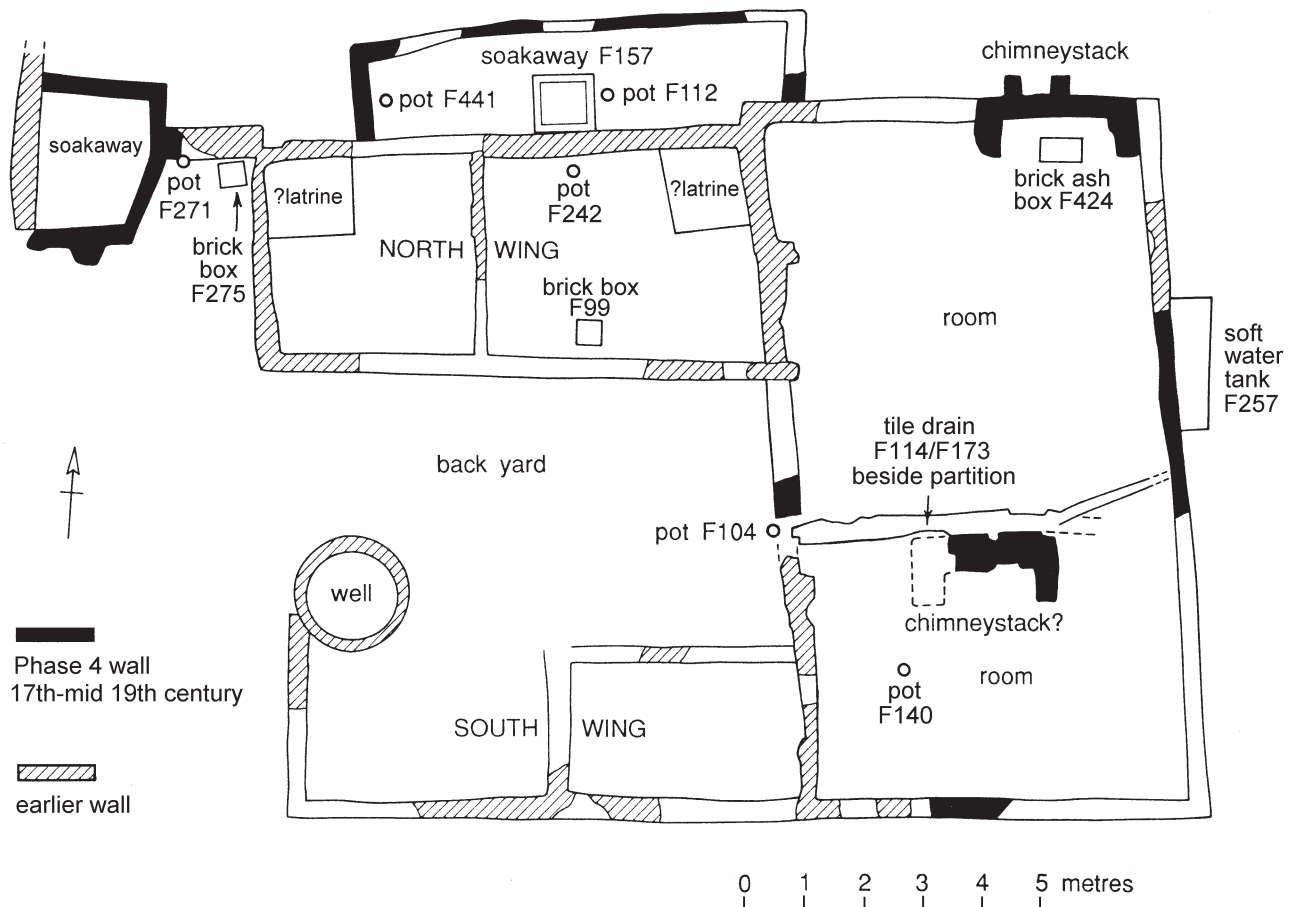

Fig 151 Post-medieval red earthenwares: location plan of buried pots in Building 75 at Middleborough.

Pot F441 (not illustrated). Flat base of storage jar (as Fig 152.191).

This pot is also a reduced waster which has caused the internal glaze to turn black. It is heavily worn internally, particularly in the centre, where intense localised wear has worn a depression. It contained coal and coal dust with some sand. Located at the central west end of the same corridor in which pot F112 occurred. A brick floor (F106), which clearly post-dates the pit containing pot F112, continued west sealing pot F441 which was either badly damaged in the process or may never have been complete in the first place. Presumably its rim or break had once been flush with an earlier floor contemporary with that containing pot F112.

Despite consideration of all the available evidence, no definite conclusions could be reached as to the function of the six buried pots. It seems fairly clear, however, that they were probably all contemporary in use and buried around the middle of the 17th century. It also seems likely that good pots were not buried where old, damaged or faulty pots would serve just as well. Two of the pots were wasters or 'seconds' (F104 & F441); one could already have been a few decades old (F242); the cauldron (F112) had half a leg missing and had clearly seen service as a cooking vessel; and we do not know whether the other two vessels were buried complete or not.

Among the suggestions put forward for their use was that of domestic coal or fuel holders, seeing that two contained traces of coal and one contained charcoal traces. They may, therefore, have served the same function as a number of curious, small, brick-lined boxes set in the ground around the house (F275, F99, F68). Two of these boxes occur next to hearths and contain coal, ash and other burnt material and could, therefore, be either fuel holders or raking-out pits. This explanation is unsatisfactory, however, particularly for the pots. They are rather too small to contain adequate fuel for a normal-sized fire and would have needed constant replenishing. Furthermore, the removal of coal from the pots would have been an awkward process except by hand. Also the fact that two of the pots were buried out in the yard, exposed to the elements, makes their role as fuel-holders seem even more unlikely.

At least three of the pots, and perhaps once all of them, had their rims set flush with the floor level. Pots in this situation are sometimes interpreted as sumps. As most of them were substantially complete and glazed internally, it is difficult to see how surplus water (let alone floodwater from the River Colne only 100 m north), could possibly have drained away, and the idea of outdoors pot-sumps seems even less likely. For similar reasons, including hygiene considerations, we

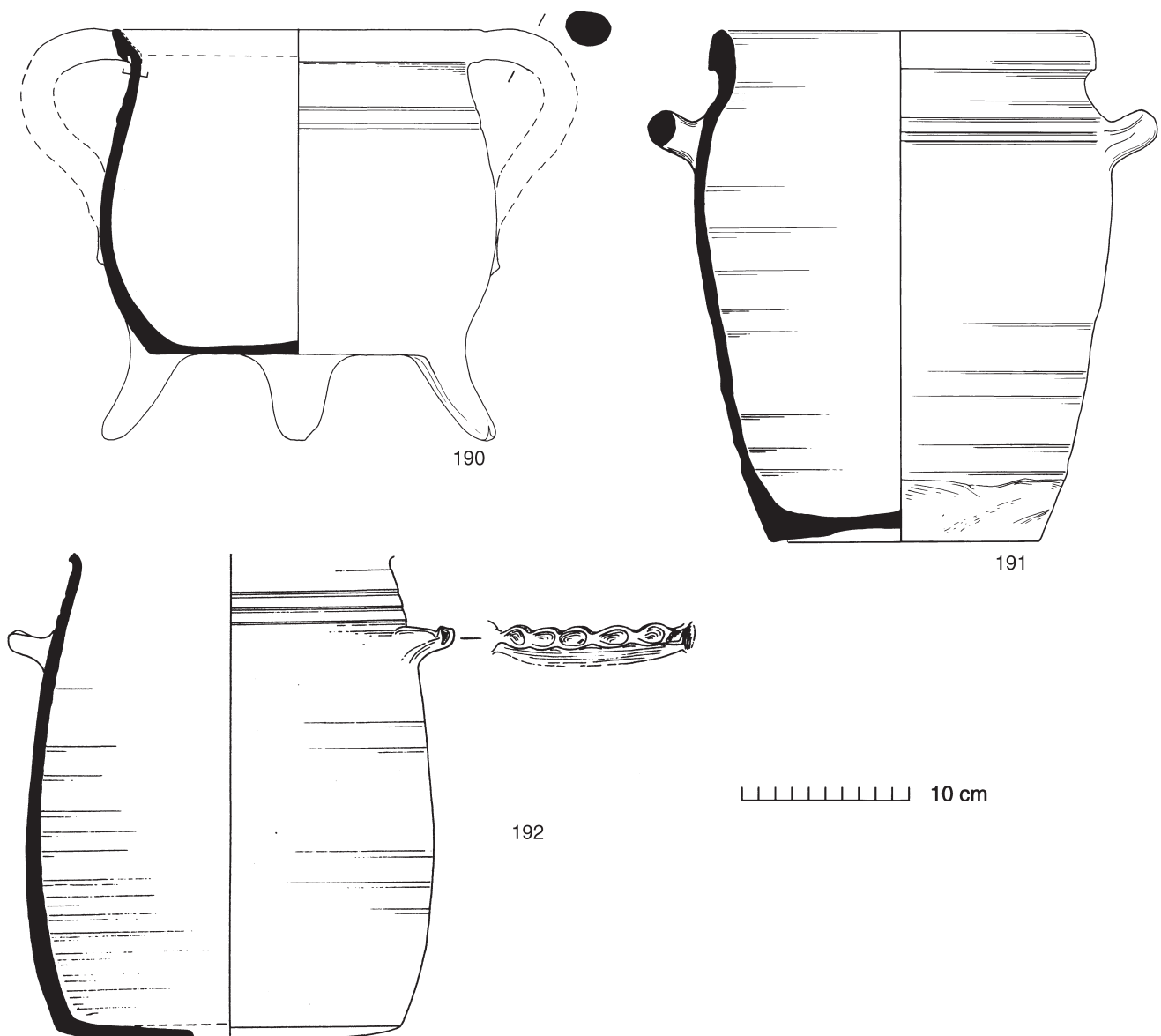

Fig 152 Post-medieval red earthenwares: three of the Middleborough buried pots c 1660 (nos 190-192). 1:4.

can also discount their possible use as urinals. Other ideas that spring to mind are their function as coolers, perhaps of milk, butter or eggs etc. This is the author's preferred view, but other interpretations are possible. The possible uses of such buried pot are endless (Moorhouse 1986, 115-17). A remarkably similar arrangement of at least four buried pots, of 17th-century date, has recently been excavated (1994) at Duck Lane, Canterbury. As at Middleborough the site lay close to a river but there were no obvious clues as to their original function.

#### Metropolitan slipware (Fabric 40A)

[Figs 153.193-204 & 154.205-208]

Just under 2% (by EVEs) of the Fabric 40 assemblage (or 141 sherds), is decorated with trailed white slip in the Metropolitan slipware style. These wares were made in west and central Essex, most notably at a number of production sites around Harlow (Newton *et al* 1960), at Loughton (Clark *et al* 1972), and to some extent at Stock, near Chelmsford (Cunningham 1985 & Fig 50.19-20). Harlow products are better known since it was from here that London received

the bulk of its slipwares in the 17th century. Smaller amounts were exported to East Anglia and as far north as the Island of Lindisfarne, Northumbria, while the American colonies mark the extremes of its distribution (Nöel Hume 1980, 102-3). Inscribed and dated vessels suggest that Metropolitan slipware was in production by *c* 1615. Recent excavations at Chelmsford, however, produced sherds of Metropolitan slipware from the late part of a phase dated to *c* 1560-90 (Cunningham 1985, 64). However, re-examination of these particular contexts has yielded no incontrovertible proof that they may not also be of early 17th-century date (Carol Cunningham, pers comm). Whilst the presence of late 16th-century Metropolitan slipwares remains a possibility, further evidence of its existence is still needed.

With a few exceptions, the bulk of Metropolitan wares from Colchester occur in the same oxidised finely sandy or silty and often finely micaceous fabric typical of these wares, and in the main the range of vessel forms and slipware designs present are easily paralleled with material (both published and unpublished) from Harlow and Loughton. There are, however, a number of fabric and decorative variants present in the collection which could represent sources other than Harlow and Loughton. Most of these significant variants are illustrated here (Fig 153.196, 200 & 203). Of these the mug Figure 153.196 has a much sandier, brighter fabric than normal and an atypical form and decoration. Figure 153.200 is in a very smooth fine Central Essex-type fabric and again is of atypical boldly flanged form and unparalleled decoration. Figure 153.203 is not greatly dissimilar to the usual finely sandy Metropolitan fabric, but it has a poorly sorted texture with moderate coarse inclusions of sub-rounded to angular quartz and flint (generally 1 mm across but as large as 4 mm), some of which erupt through the surface. The form, unusual thinness of the walls and unusual polkadot decoration are also unparalleled in the normal range of Metropolitan slipware. The possibility that the atypical vessels described above could be Continental imports has been investigated, but in all three cases a Continental source has been discounted in preference to an unknown source or sources in Essex (David Gaimster & Beverley Nenck, pers comm).

Atypical designs, such as the frieze of three spirals around Figure 153.196 (and traces of slip ?dashes on the rim) may have been inspired by Dutch slipwares (and perhaps in the case of Fig 153.199 also). The parallel wavy-line decoration on Figure 153.200 could be in imitation of Staffordshire combed slipware dishes (but in reverse colours), while the polkadot decoration of Figure 153.203 is clearly inspired by dishes in Lower Rhineland slipware, common in the period *c* 1675-1750 (see Fabric 44C, p 292). This would fit with the *c* 1680-1700 date of Stratified Group 21 from which this dish comes. A slipware production site at Canterbury (recently identified by the author) was also producing slipware dishes with polkadot and other Rhenish-style designs during the period *c* 1690/1700-75, but the fabric is much coarser than any of the atypical vessels described above, thus reinforcing the likelihood of an Essex source for these pieces. A fourth variant piece from Stratified Group 21 is described below.

Although in general the Colchester material differs little from the known range of Metropolitan products, it is unusual for the late date at which it arrives in any quantity in the town and unusual, furthermore, for the ratio of flatwares to hollow-wares which is completely the reverse of that shown

by ordinary Fabric 40. Whereas plain Fabric 40 is dominated by hollow-wares, in particular various types of jar, the Metropolitan material is dominated by flatwares, particularly dishes which comprise 82% of all forms, followed by bowls (11%), and finally by miscellaneous forms including jugs and jars.

It is a general observation that most inscribed and dated Metropolitan slipware vessels are hollow-wares belonging to the first half of the 17th century (Jennings 1981, 97). If slipware jars in general are indicative of the first half of the 17th century, then their virtual absence from Colchester is a strong indication that the majority of vessels in Metropolitan slipware must have arrived later than this, as indeed seems to be the case. This is in contrast to the Metropolitan assemblages found at Chelmsford to the south (Cunningham 1985, fig 40.1-8) and at Norwich to the north (Jennings 1981, figs 39 & 42.684), where jars and hollow-wares are relatively more common although dishes still predominate.

The earliest possible occurrence of Metropolitan slipware in Colchester is a sherd from a jar or jug from a 17th-century cess-pit (LWC CF18) containing a coin of 1613-25, a clay tobacco-pipe stem and a compatible range of other pottery. This pit was cut by another (LWC CF20), containing a coin of 1625-44. It is, of course, possible that both these coins may be slightly residual. The small jar Figure 153.195 came from a pit context of, perhaps, *c* 1660, which contained a coin of 1636-44 and clay tobacco pipes of *c* 1640-80. The same context also produced two slipware dish rims.

Figure 153.193, with its Puritan inscription 'Hate Vice', is the only definite Metropolitan slipware jug from the excavations. It probably dates to the mid 17th century, and was associated, among other things, with a set of Dutch tingle-glazed plates of *c* 1630-40 (LWC C95; Fig 160). The cup or small bowl Figure 153.194 was found with clay tobacco pipes of *c* 1640-60, and the mug (Fig 153.196) came from a mid 18th-century context. To these we may add two or three other sherds from hollow-ware forms bringing the total number of such vessels to around six or seven.

Explanations for the relatively insignificant numbers of Metropolitan slipware jars and jugs could include a decline in the number of these forms being produced in the second half of the 17th century, coupled with competition from other wares such as Continental and Staffordshire slipwares, tingle-glazed wares, etc. Although present from the middle of the 17th century, Metropolitan slipware dishes become increasingly common in Colchester between the years *c* 1675-1725 or 1750 (eg Stratified Group 21, *c* 1680-1700; Fig 242.47-57). This fits well with their appearance at Chelmsford where dishes appear *c* 1670-1700 and continue into the 18th century (Cunningham 1985, 64).

Unusual items in Stratified Group 21, besides the polkadot dish (Fig 153.203) discussed above, include a small dish with a piecrust rim (Fig 153.201), and a very overfired, dark purplish 'second' (Fig 242.49). While nearly all specimens have the same fine or slightly sandy fabric, Figure 242.56 has an unusually coarse fabric charged with coarse pale brown clay pellets erupting through the surface and covered by a dark brown, treacly internal glaze (see above p 192). Items of interest from other contexts include the atypical dish Figure 153.200, already mentioned, and found with two Westerwald stoneware mugs of *c* 1700. Figure 153.202 bears what appears to be a fragmentary dated inscription ending '(17)18', but it is not impossible that this could simply be part of some unintelligible design.

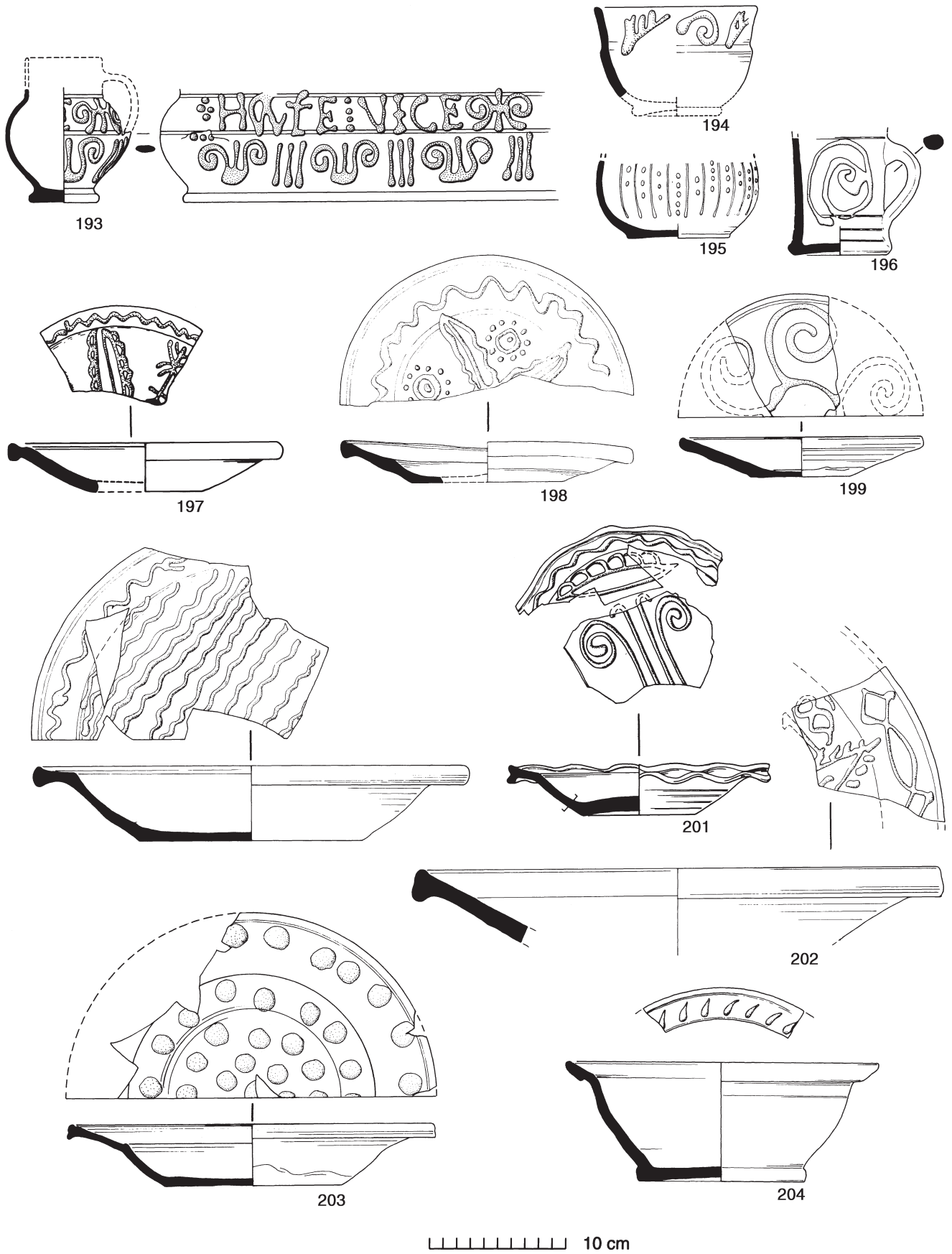

Fig 153 Metropolitan slipware: jug (no 193); small bowls or cups (nos 194-195); tankard (no 196); dishes (nos 197-203); bowl (no 204). 1:4.

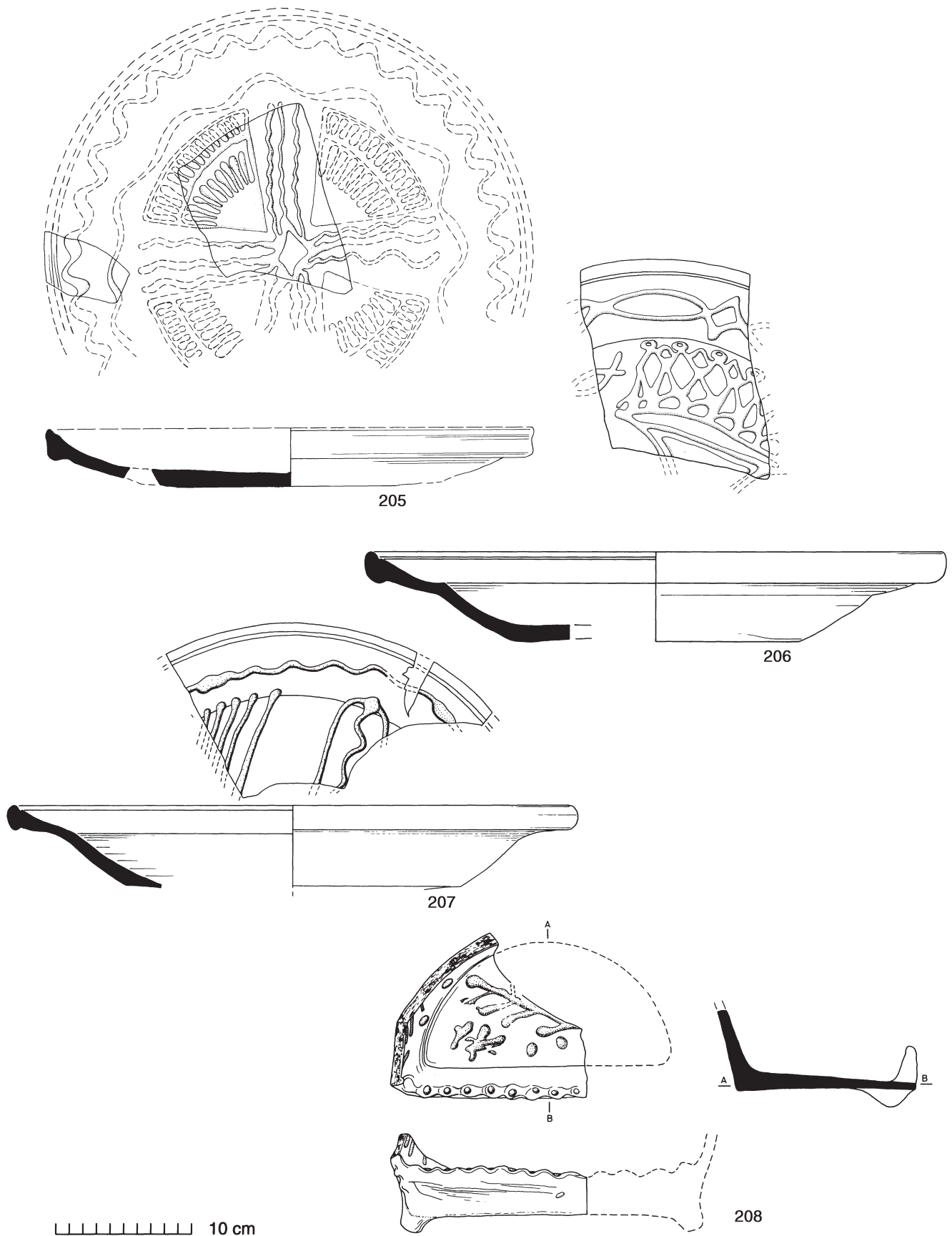

Fig 154 Metropolitan slipware: dishes (nos 205-207); Dutch oven (no 208). 1:4.

Bowls (eg Fig 153.204) occur from the mid 17th century but are uncommon. In Stratified Group 22 (c 1730-40), Metropolitan slipware is represented by only one or two dish rims (Fig 245.18) and a slip-decorated handle, possibly from a bowl (not illustrated). However, a contemporary early 18th-century pit (BKC VF185) contained at least seven very large slipware dishes (Fig 154.206-207) and a 'Dutch oven' (Fig 154.208; see below). This context also contained a slightly residual coin of ?1672-9, and fifteen clay tobacco pipes of c 1700-40. Figure 154.205 came from a nearby early 18th-century pit. Eventually all Fabric 40 dishes, first plain, then slip-decorated, disappeared as the 18th century progressed.

The early 18th-century Dutch oven (Fig 154.208) is perhaps the most unusual and interesting Metropolitan slipware item from the excavations. This was wheel-thrown as a jar or deep bowl and then cut in half. A wall of clay was then added along the straight side and two tripod-like feet to the underside. Crude decoration in a very thick trailed white slip was then carried out on the internal floor and walls and blobs of slip decorate the thumbled rim of the inserted wall and possibly carried on up the sides. The whole vessel (including the underside) was then covered in a clear glaze and fired upside-down. Slightly off-centre, there is a rough, glaze-covered edge, at right-angles to the flat side. The roughness of the edge is in keeping with a severe flaw which, although not rendering the vessel entirely useless, must nevertheless have rated it a bad 'second' as far as selling-price was concerned. The underside, particularly the foot, shows signs of wear, but there is no trace of soot-ing despite its intended function as a fireside roaster (Brears 1971, 108; for plain examples see Jennings 1981, fig 77.1298-1301).

### Border ware (Fabric 42)

[Figs 155-6]  
Weight: 20.180 kg  
Number of sherds: 852\*  
EVEs: 16.27\*

Border ware was produced at various sites along the border between Surrey and Hampshire during the 16th and 17th centuries (Pearce 1992). Production sites have been excavated in this area at Ash (Holling 1969) and Cove (Haslam 1975). These white wares may be seen as a development of the medieval green-glazed white-ware industries of this region and perhaps especially so of their fine-ware component 'Tudor Green' ware. Border wares are very widely distributed across southern England.

The fabric is slightly sandy, and off-white, buff or pink with moderate inclusions of fine red and black iron oxide. Most vessels are covered only on the inside with an even transparent lead glaze although external splashes are common. The glaze may be either clear (showing yellow or greenish), or green and copper-flecked, or brown and iron or manganese-flecked. It is not uncommon to find external splashes of glaze different in colour to the main internal glaze. While such occurrences are probably accidental there are also some deliberate instances where vessels

received a bichrome glaze (ie clear inside, green outside). One jar rim has a kiln scar of red clay either from an item of kiln-furniture or from a redware vessel in the same firing. The majority of vessels from Colchester are clear (yellow) glazed but green-glazed vessels are not uncommon. Brown-glazed vessels (a few bowls and a mug) are fairly rare.

Vessel forms, as found in Colchester, may be broadly divided into bowls (47%), jars (26%; including bowl-like skillets), dishes or platters (19%), and rarer or miscellaneous forms (8%). However, distinctions made here between bowls, particularly wide, deep pancheons (Fig 155.1-5), and dishes (Fig 155.6-10), are rarely based on whole profiles but rely on the angle of the wall along with rim characteristics (generally wider, less robust flanged rims for dishes). These distinctions should not therefore be taken too literally; they were made before Pearce's thorough classification of these wares (Pearce 1992) and so do not coincide exactly with dish/bowl distinctions given there.

Bowls comprise nearly half of all forms and there are two main types. Pancheons (Fig 155.1-5) are wide and deep, usually with relatively complex flanged rims. Rim diameters cover the range 170-420 mm with clusterings around 240 mm and 320 mm. This pattern mirrors that found for platters and plates at the Cove kiln (Haslam 1975, fig 2). One rim fragment (LWC A1; not illustrated), perhaps from a wide bowl, has combed decoration on the flange (as *ibid*, fig 4.23). The other main bowl type is mostly comprised of small and usually carinated 'porringers' with a simple or beaded rim and often a single horizontal loop handle, more rarely a pair (Fig 155.11-13). These have a diameter range of 110-170 mm but are mainly 110-140 mm.

Dishes comprise one-fifth of all vessel forms. These are shallower than bowls and most have relatively broad flanged rims (Fig 155.8-10). Diameters range from 110 to 400 mm but are mostly under 340 mm. Two or three examples have stamped 'sunburst' decoration on the rim (Fig 155.9-10), and one small rim sherd has an impressed or incised decoration of interlaced arcs or possibly circles (LWC G8; not illustrated). Figure 155.6-7 represent a rarer dish type characterised by a straight outward-leaning wall and a very simple rim sometimes with 'piecrust' or 'cogged' decoration. Figure 155.6 is unique in that it is completely unglazed and has a sagging base, but in all other respects it conforms with the characteristics of Border ware. It might possibly be a lid (Pearce 1992, fig 45.436-9) but there is no evidence of a knob.

Jars of various sorts account for just over a quarter of all forms, although this figure includes skillets (Fig 155.14-16) which could be considered a type of bowl. Skillets and pipkins (Fig 155.17) with tripod feet and tubular handles occur in roughly equal numbers. Pipkins occur both with internal and external lid-seated rims (as *ibid*, fig 27.134-46 & fig 28.149-54 respectively). Ovoid or globular jars (Fig 156.18-19) are also fairly common and some of these must have served as chamberpots. Pearce classifies these as type 1 (Fig 156.18) and type 2 (Fig 156.19) chamberpots (*ibid*, fig 39, fig 40.323-30 & fig 41.332-6). Type 1 is dated early to mid 17th century; type 2 is late 17th century. However, the type 1 chamberpot shown here (Fig 156.18) is from a context of 1680-1700 (Stratified Group 21); the other vessel is unstratified.

Rarer forms are normally represented by no more than three examples and often by only a single example. There are three examples of drug jars. Figure 156.20 (see below)

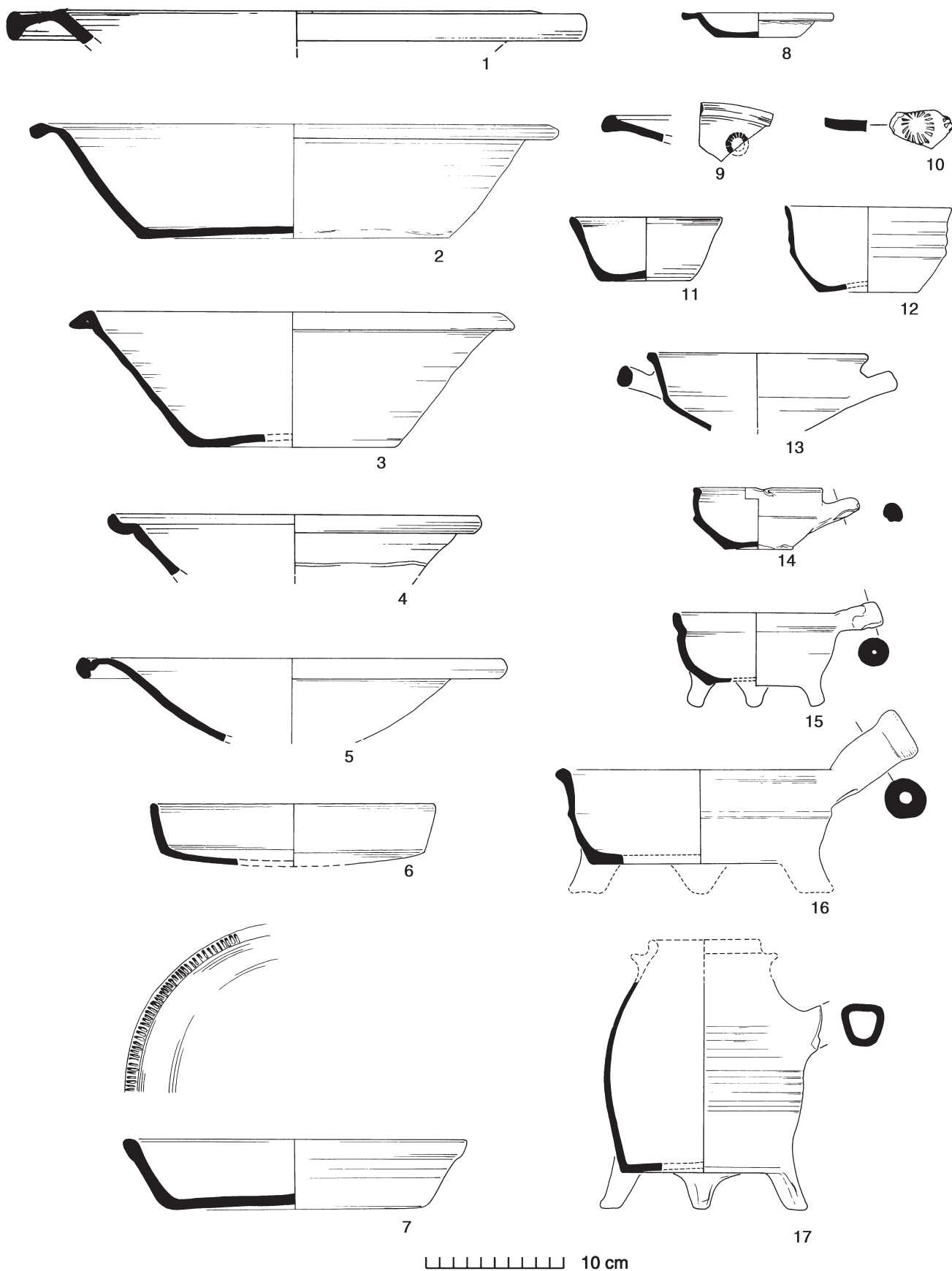

Fig 155 Border ware: bowls or pancheons (nos 1-5); shallow bowls or dishes (nos 6-7); dishes (nos 8-10); small bowls or porringers (nos 11-13); skillets (nos 14-16); tripod pipkin (no 17). 1:4.



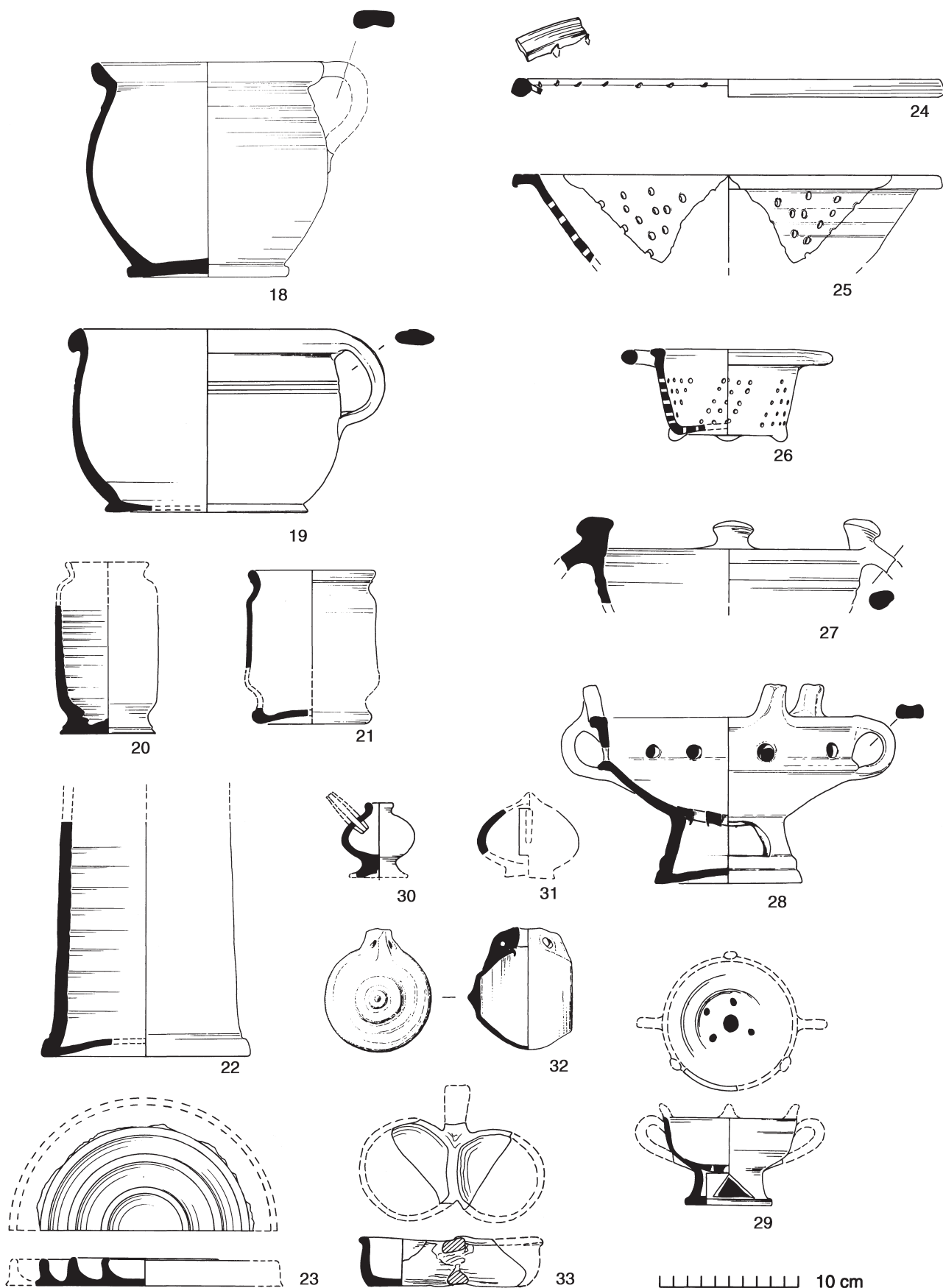

Fig 156 Border ware: chamberpots (nos 18-19); drug jars (nos 20-21); butter pot (no 22); chicken-feeder (no 23); strainers (nos 24-26); chafing dishes (nos 27-29); whistle (no 30); moneybox (no 31); costrel (no 32); condiment (no 33). 1:4.

is only partially glazed with two bold external splashes of thick, deep green glaze. Figure 156.21 has a clear glaze inside and a green glaze outside. This vessel came from soil immediately overlying a presumed apothecary's dump (Stratified Group 20, c 1650) and is almost certainly derived from it. The tall cylindrical vessel Figure 156.22 is unique in the collection and is best identified as a butter pot (as *ibid*, fig 45.426). The interior is unglazed but the outside is clear glazed and there are extensive splashes of green glaze under the base. Figure 156.23 (Stratified Group 17, c 1625-50), is the only example of a form generally known as a bird or chicken feeder. At least three strainers are known, all of these glazed inside only (Fig 156.24-26). On Figure 156.26 (Stratified Group 19, c 1650), the perforations are arranged in alternating groups of upright and inverted triangles and the interior is green glazed. The three chafing dishes found are represented in Figure 156.27-29; the last example being remarkable for its small size. A tightly curved sherd (Fig 156.31; Stratified Group 21, c 1680-1700) almost certainly comes from a small moneybox, and another sherd (LWC AF28; not illustrated) comes from the finial knob of a second example (as *ibid*, fig 43.368-89).

Other rare Border ware forms include a whistle (Fig 156.30) in the collection of Colchester Museum. This has a fairly sandy white fabric covered externally with a golden-yellow glaze. The broken tubular mouthpiece looks as if it was separately fired and glazed before it was inserted into the otherwise unglazed body cavity. In form it is almost identical to two examples published from London (*ibid*, fig 45.428-9). A virtually complete mammiform costrel covered with mottled green glaze (Fig 156.32) was recovered from Stratified Group 17 (c 1625-50), and one other sherd from a bottle-shaped costrel with a pierced lug handle (as *ibid*, fig 37.289-300) was found elsewhere (LWC AF12; not illustrated). A single yellow-glazed condiment is known (Fig 156.33; Stratified Group 21, c 1680-1700), and there is a single sherd probably from a lid (LWC CF42). No Border ware jugs have been recognised.

There are only two basal sherds (not illustrated) that can be attributed to mugs: a green-glazed encrusted mug with a pad base (as *ibid*, fig 36.275; MID F387, 18th century), and a brown-glazed moulded base from a straight-sided mug with traces of incised vertical decoration on the body (as *ibid*, fig 36.281; LWC G20, probably derived from Stratified Group 18, c 1625-50).

One peculiar little sherd (not illustrated; LWC AF6) probably comes from a 'roaster', similar to one in the Ashmolean Museum, Oxford and a German example from Duisburg which is illustrated by Gaimster (1993, fig 8r). These are thrown as a long cylinder with one flat and one hemispherical end. The vessel was then asymmetrically bisected longways and then set in a horizontal position upon four applied 'tripod' feet. The upper half or cut-away section then became a lid while the plain rim it rested upon was strengthened by the application of an external thumbled strip. The inside of the vessel is clear glazed. An alternative, but less likely, identification is that of a candle sconce; the context is late 17th/early 18th century.

Possibly the most unusual Border ware items from the excavations are two fragments of stove-tiles from Maldon Road and Crouch Street. These have been published by Gaimster (1988a, fig 2.3-4) and represent his type I matrix bearing the arms and initials (HR) of Henry VIII. Tiled stoves were a late medieval fashion imported from the Continent,

but which seems to have died out in England during the early 17th century. Both Colchester stove-tile fragments come from rubbish-pits in the general vicinity of a religious foundation known as the Crouched Friars (see above p 10). This is the sort of high-status site with which stove-tiles were generally associated. After the Dissolution of the friary (at an unknown date) the building was converted into a private residence which was almost completely destroyed during the 1648 siege of Colchester, at which date the tiles may have been discarded (CAR 9, 251-3).

With a few exceptions, the great bulk of Border ware seems to come rather late to Colchester where it is not very common until the mid to late 17th century. This, however, may be something of an illusion created by the paucity of contexts securely dated to the second half of the 16th and the start of the 17th century, in contrast to the abundance of later well-dated contexts. The earliest occurrence of the fabric in the town is probably the two stove-tiles of Henry VIII (1509-1547). Two drug jars (including Fig 156.20) come from a pit group (LWC KF64) which contained a range of wares, including a Valencian lustreware drug jar, suggesting a deposition date of c 1500-50. The context could be an apothecary's dump (see p 232, Fig 158). The two Border ware drug jars from this group have a very fine, off-white fabric, slightly micaceous and lacking the red inclusions typical of normal Border ware. Internal throwing lines on both vessels are very pronounced and the exterior has impressions from handling in the wet state. Both vessels are only partially glazed externally; one green and the other clear glazed. These slightly unusual characteristics might have suggested a Continental source but their Border ware identification is confirmed (Alan Vince, pers comm, 1987).

No other 16th-century context covered by this volume has produced Border ware, but a pit group of c 1600 from the Angel Yard site produced a pipkin and possibly other forms in this ware together with a stoneware medallion dated 1585 (40.86 F76). Two major pit groups of c 1625-50 produced vessels in this ware: those in Stratified Group 17 include the 'chicken feeder' (Fig 156.23) described above and a possible bowl base; those in Stratified Group 18 (not illustrated) include dishes, bowls with flanged rims and 'porringers'. Thereafter Border ware is commonly found throughout 17th- and early 18th-century contexts in the town. In Period 4.2 the ware comprises only 0.25% (by weight) of the assemblage; in Period 5.2 it comprises 1.1% (and 3.1% EVEs), and 5% (7.2% EVEs) in Period 5.3.

## Netherlands, Anglo-Netherlands and English tin-glazed earthenwares (Fabric 46)

[Figs 157-66]  
Weight: 35.330 kg  
Number of sherds: 2,097\*  
EVEs: 41.55\*

*Thanks are due to Michael Archer of the Victoria and Albert Museum for his assistance in identifying this material and for his comments on the text.*

Just as Italian emigrants were the first to produce tin-glazed

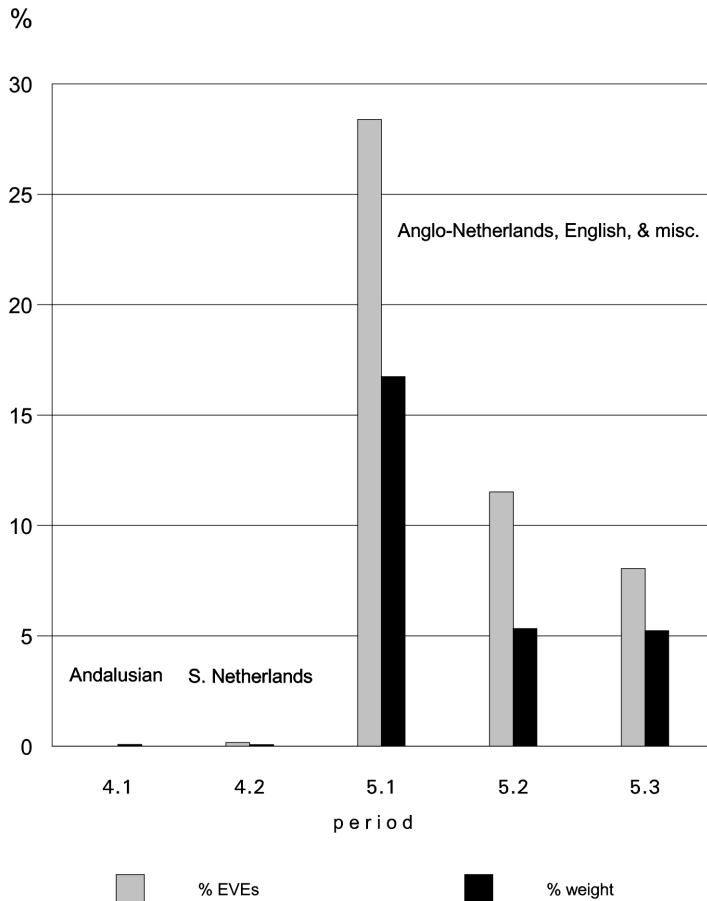

Fig 157 Netherlands, Anglo-Netherlands and English tin-glazed earthenwares (Fabric 46): bar chart showing percentages of all tin-glazed wares in stratified contexts (ceramic periods).

pottery in the Netherlands, so it was emigrants from the Netherlands who first made tin-glazed pottery in England. After a short sojourn in Norwich, Jasper Andries and Jacob Janson from Antwerp established a pottery in London in 1570, probably at Aldgate, and this remained active until c 1625. Although there is no evidence that inscribed drug jars were produced, the pharmaceutical and other wares produced there were very much in the same tradition as those produced by contemporary potteries in the Netherlands (Drey 1978, 129-30). Similar wares were produced at the Southwark factory opened in 1618, again by a settler from the Netherlands.

These artistic links with the Netherlands were particularly strong in the early 17th century and to a lesser extent throughout the first half of the 18th century. Again, in the latter part of the century the influence of the factory at Delft left its mark on English tin-glazed pottery. The similar reddish, pinkish, buff or cream fabric used by English and Netherlands tin-glazed potters is of limited use in distinguishing their products. As a rule, however, the reddish or pinkish fabric is more characteristic of Netherlandish products of the 16th and first half of the 17th century, but firmer attributions must take into account such art-historical criteria as shape and decoration. For these reasons no serious attempt has been made here to quantify the excavated material in terms of probable source, although individual identifications are offered for the illustrated material. Because of the large numbers of highly decorated drawable items, vessels considered to be very close in design to one already illustrated were therefore not selected for

illustration. This typology should therefore be regarded as a selection of the various designs and forms present. Colchester's large collection of tin-glazed pottery almost certainly includes many vessels from the Netherlands, particularly pharmaceutical vessels such as drug jars and slack-sided *albarelli* (which together comprise just under a third of all tin-glazed vessels found). In view of Colchester's strong historical trade links with the Low Countries, it seems likely that a substantial number of vessels, classified simply as 'Anglo-Netherlands', could well represent genuine imports.

Jasper Andries was briefly a resident of Colchester in 1571, as was his brother Lucas in 1573, but there is no evidence that they ever tried to make pottery here (see Appendix 2, p 366).

### Drug jars, apothecaries and pit groups

[Figs 157-161]

As most of the vessels illustrated here, particularly the drug jars, come from just a few large pit groups, it seems convenient to consider some of these within their archaeological contexts, using the groups as a reference point for similar but less well-stratified examples appearing in the illustrated typology. At least half-a-dozen pit groups and pit complexes in the Lion Walk area contained anything between four and twenty or more tin-glazed drug jars. Many

of these were reconstructible and one or two were discarded whole. Several have pharmaceutical inscriptions listing their original contents and these are discussed below (pp 244-5, Fig 166.1B-18B). Archaeologically there are some grounds for considering these pit groups (or at least the largest) to be apothecaries' dumps. The large numbers of drug jars alone are a strong indication. Along with these the large quantities of high-quality Rhenish stonewares and local domestic storage jars and pancheons might also have seen service in an apothecary's shop. Furthermore it was observed that the large tin-glazed dishes or chargers, so common elsewhere in 17th-century contexts in the town, were rare or absent from these pit groups; being purely decorative and non-functional they would have been of little use to an apothecary. The glass from these pits awaits study, and there is little in the way of associated finds that supports the apothecary theory, except perhaps for a small complete triangular crucible from one of the pits (Stratified Group 19; Fig 197.1). Like many of the stonewares and local domestic storage vessels from the pit groups, the indications are that many of the drug jars were quite old at deposition, ie anything between 25 and 75 years old.

It was evident even at the time of excavation that there was something special about the large concentration of tin-glazed vessels from Lion Walk. Nowhere else in the town have excavations produced so many drug jars, the great majority of them dating to the first half of the 17th century. Areas of comparable size, such as the Culver Street and Middleborough excavations, produced only three and six drug jars respectively, mostly plain. Even at a conservative estimate, Lion Walk produced no less than 77 drug jars, the great majority decorated. The conclusion that so many drug jars must have originated from one or more apothecaries' workshops in the near vicinity was a logical one, and one that is largely supported by the subsequent documentary work outlined below.

### Apothecaries at Lion Walk in the 17th and 18th centuries

(Some of the information summarised below is from unpublished sources kindly made available by Mr John Bensusan-Butt and also from the parish registers of St Nicholas' Church.)

In the 18th century, Lion Walk (formerly Cat Lane) was sometimes known as Red Lion Walk due to its connection with the Red Lion Inn (now Hotel) which stands at its northern end fronting the High Street (Fig 158). The eastern frontage of Lion Walk, which lay in St Nicholas' parish, belonged to the Red Lion Inn and until its sale in 1741 this frontage had mainly been used as gardens and partly as a timber yard. Thomas Great, an apothecary and owner of the Red Lion, sold the Inn and plot in 1722 to George Gray (Blaxill 1938, 19). Thomas was the son of Samuel Great, apothecary, apprentice to Robert Buxton, apothecary, about whom the 18th-century historian Morant had this to say:

'...let me subjoin another thing which Colchester is famous for, viz. the excellent sweet-meats made of *Eryngo-Roots*. They were first candied in this town about the beginning of the last century by Robert Buxton Apothecary. His apprentice Samuel Great continued this business, and it hath been ever since carried on by the latter's posterity with universal liking and approbation.'

(Morant 1748, 1, 88)

Robert Buxton (1577-1655) is mentioned in a Decree in Chancery made on 9 November 1603 (Morant 1748, 3, 4). By this, ten parishioners of the Parish of St Nicholas are named as trustees of a bequest to the parish. Those named include both 'Thomas Buckstone Apothecary' and 'Robert Buckstone Apothecary'. Thomas was either Robert's probable father Thomas Buckstone (1549-1607) or his older brother of the same name (born 1569; it is not certain which of these died in 1607 but there are indications that it was the father). Thomas Buckstone may well be the Thomas Buxton who was both executor and a beneficiary of the will of John Latimer of St Nicholas' parish, who died in 1575 (Emmison 1969, 3, no 845). Other Buxstones (relatives of Thomas) are also named in the will.

Although he was not the inventor of candied eringo roots (made from the roots of Sea Holly), Robert Buxton perfected the recipe which was kept a closely-guarded secret by his successors (the Great family) until the 19th century. The earliest mention of eringos in the town was in a bill paid in 1606-7 to a certain John Howedon about whom nothing else is known (Shenstone 1907, 371-2). A similar bill was paid to Robert Buxton in 1615-16 (*ibid*). Buxton was twice mayor of Colchester (1635 and 1645) and was an alderman during the siege of 1648, siding with the Royalist cause which led to his later expulsion from the Corporation. His tombstone did not survive the unfortunate demolition of St Nicholas' parish church in 1955 but fortunately it had already been noted by Morant: *Robertus Buxton Pharmacopola, 1655* (Morant 1748, appendix 3, 51). It is uncertain whether Buxton, like his apprentice, was also the owner of the Red Lion Inn and the adjacent apothecary's shop that certainly existed by the early 18th century, but it seems likely. It seems probable that Buxton bequeathed or sold the Red Lion Inn and the east frontage of Lion Walk (St Nicholas' Parish) to his apprentice Samuel Great, but that he had sold the west frontage (Holy Trinity Parish) to Edmund Thurston, a prominent Colchester citizen. The latter is suggested by the terms of the post-nuptial settlement of Edmund's daughter Hannah Thurston who married Ralph Creffield. In this document, executed 2 May 1662, the couple settled freehold premises in the parishes of St Nicholas and Holy Trinity, 'lately occupied by Robert Buxton, Gentleman, deceased, and then in his own occupation' (Sier 1943, 161-2).

Samuel Great (1625/6-1706) was the son of Samuel de Groot, a weaver of Colchester's Dutch community. His apprenticeship to Buxton probably began in the 1640s after an education at Colchester Royal Grammar School (Round 1897, 29). Great established a dynasty of apothecaries and grocers whose principal shop was on the High Street adjacent to the Red Lion Inn and which advertised itself at the sign of 'The Old Twisted Posts & Pots'. These were the emblems used by the family on wine bottles and on their boxes of eringo roots from at least the early 18th century onwards (see examples in Colchester Natural History Museum). In 1971-2 a small excavation was carried out by Colchester Museum at 45-46 High Street, beneath a cellar on the presumed site of the Greats' apothecary shop. The cellar itself contained a working-oven of brick which might have been connected with their trade. Not surprisingly there was little in the way of post-medieval pottery recovered (the cellar being recently in use), but, significantly, a wine bottle found on the site bore the inscribed seal of *THOMAS GREAT COLCHESTER* and the emblem of the twisted posts and pots (Davies, pers comm). Samuel Great's son

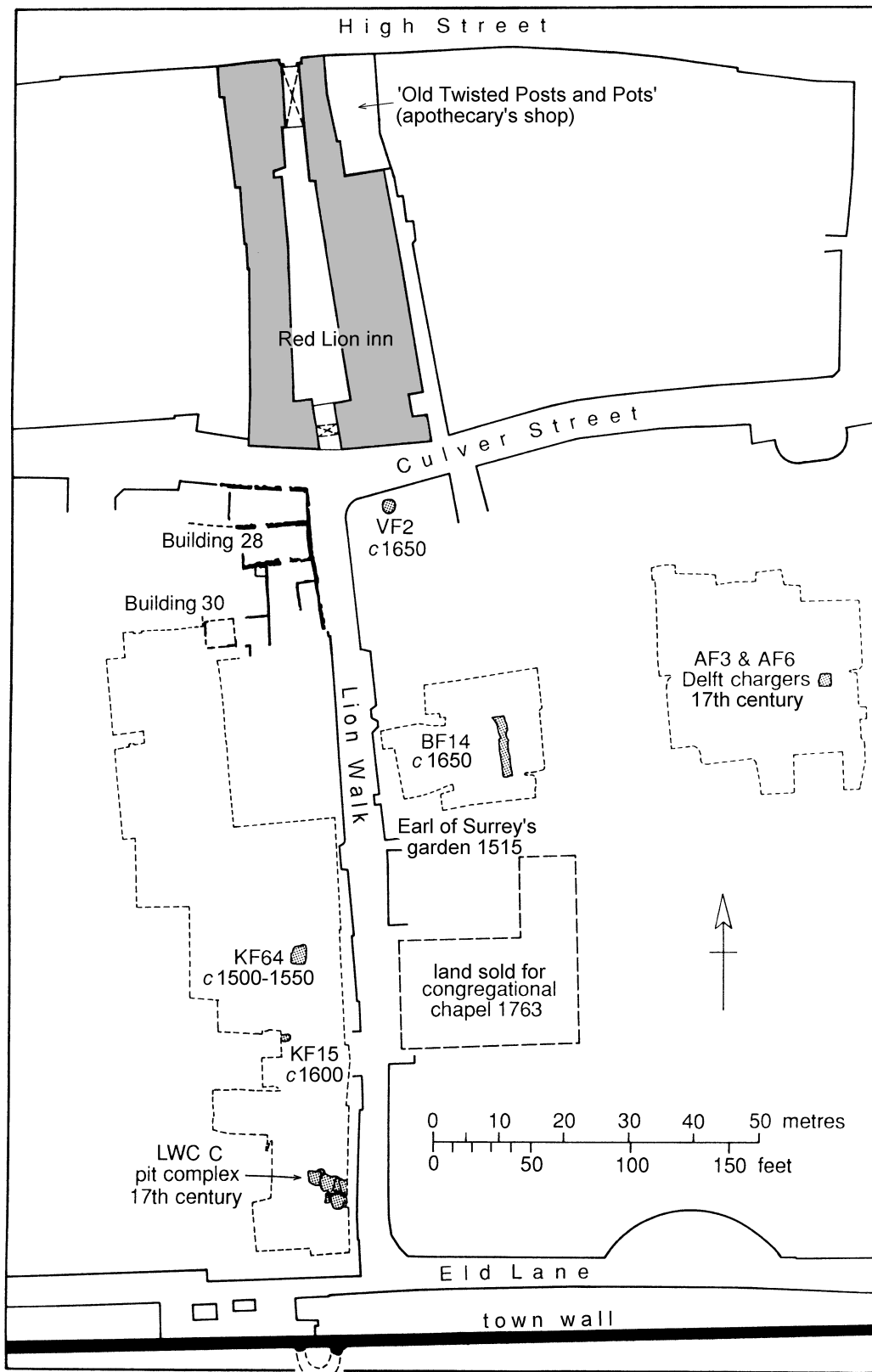

Fig 158 Plan of Lion Walk showing the location of the 16th- and 17th-century apothecary dumps and related topography.

and grandson (both called Thomas) were practising apothecaries. The last of these died in 1762 (Prerogative Court of Canterbury will). Another grandson, Charles Great, a grocer, continued making eringo root until his death in 1797.

There was a large number of apothecaries (at least 20 all told) operating in the town during the 17th and 18th centuries, mostly along or near the High Street. Many of these were considerably wealthy and a good deal of intermarriage took place between the families of wealthy Colchester apothecaries and grocers, including the Great family. But these matters do not directly concern us here.

However, it seems clear that, for over a century and a half (between *c* 1600 and 1762), a succession of apothecaries operated from premises on the High Street adjacent to the Red Lion Inn, and that until 1722 they also owned the inn and the eastern frontage of Lion Walk. The west frontage had passed from their ownership by *c* 1655. There can be little doubt therefore that the unusually large numbers of drug jars from the excavations at Lion Walk represent rubbish dumped by these apothecaries. The contents of the pits, however, could represent a mixture of rubbish derived both from their workshops and the Red Lion Inn. The eastern frontage of Lion Walk produced two of the most important groups of drug jars: Stratified Groups 19 (LWC VF2) and 20 (LWC BF14), both dated to *c* 1650 on the basis of their contents. It is naturally very tempting to link the deposition of these two groups with the death of Robert Buxton in 1655, and it does not seem too fanciful to imagine Samuel Great, the former apprentice, taking this opportunity to have a good clear-out of all the old pots and stock accumulated by his late master.

It is interesting to note that the larger site areas A and R, lying 20 m east of the above-mentioned groups and on land not belonging to the Greats, produced only one or two sherds from drug jars. Like the east frontage, the west frontage of Lion Walk also produced large numbers of drug jars. Morant's map of 1748 shows the west frontage with a small number of houses with intervening garden plots and behind these the extensive ornamental gardens of Trinity House. It was in this south-west sector of Lion Walk that a pit containing many fine drug jars was excavated (LWC KF15, *see below*). The contents of this pit suggest a deposition date of *c* 1600 and one is similarly tempted to see a link between this pit and the activities of both Thomas and Robert Buxton late in the reign of Elizabeth I.

There is some evidence that apothecaries were active in this neighbourhood even before this date. On the same site, and lying only 11 m slightly north-east of the pit group of *c* 1600, was another large pit whose contents predate the above. This earlier pit (LWC KF64) contained at least a dozen Raeren stoneware drinking vessels (*c* 1475-1550), a large quantity of Colchester-type ware of comparable date and an early Fabric 40 jug in Central Essex-type fabric. Significantly it also produced a large sherd from the shoulder of a Valencian lustreware drug jar (Fig 199.6) and fragments from two Border ware drug jars in an unusually fine fabric (Fig 156.20). The whole group almost certainly dates to the first half of the 16th century. Similarly, a pit context of *c* 1475-1525 on Site A (LWC AF15) produced fragments of several glass alembics, used for distilling (Rachel Tyson, *pers comm*), though no drug jars. If these are accepted as a genuine dump of apothecary's material (or as containing some apothecary material) then they

predate our records of this activity in Lion Walk. Whether or not the Buxton family were connected with this early phase of activity would require more detailed documentary work to establish.

There is no shortage of documentary evidence during this period. We know, for instance, of at least two Colchester apothecaries around this time; John Mace who was burnt at the stake for his religious beliefs in 1556 (Morant 1748, 3, 50), and John Evererd of Wisbech who was admitted to the borough in 1560/61 (*Oath Book*, 181). Indeed, references to apothecaries in the town go back as far as the late 14th century (*Oath Book*, 72).

One puzzle, however, is the lack of later 17th- and 18th-century pharmaceutical vessels from Lion Walk. Given the Great family's ownership of the east frontage as late as 1722 and their continuing business as apothecaries beyond this date, one would expect to find a sequence of material including Lambeth and other English drug jars of this later period. But this is not the case. The great majority of vessels recovered are of the Anglo-Netherlands style dating to the first half of the 17th century or earlier. A trickle of these continued to be dumped (or redeposited?) in late 17th-century contexts. Perhaps the later drug jars remain to be discovered or perhaps the apothecaries on the High Street found somewhere else to dump their rubbish.

#### Pit group LWC KF15

This contained six drug jars (Fig 159.4-7 & Fig 161.10-11), and a tall, tapering, slender-necked pharmaceutical bottle (Fig 159.8). There was no associated coin or clay tobacco-pipe evidence. Associated pottery comprised a complete Cologne or Frechen stoneware girth-band *Bartmann* jug of *c* 1550-75 (Fig 193.8), and in Fabric 40 a cup (Fig 146.146), a bowl (Fig 138.70), and a complete pancheon in early Central Essex-type fabric (Fig 134.29). These associated vessels, the absence of clay pipes and of the commoner type of geometric-band drug jar (first half of the 17th century), and the style of the drug jars themselves, all suggest a deposition date of *c* 1600 for this group. The apothecary vessels are all of Netherlandish manufacture, most probably North Netherlands, and date to the second half of the 16th century. The running foliage decoration seen on most of these pieces is typical of North Netherlands *maiolica* during this period (Hurst *et al* 1986, 124). There are parallels with a collection of late 16th-century vessels from a pharmacy in Vlissingen, Holland (*ibid*, pl 20) and with a group of Netherlandish drug jars excavated at Baconsthorpe Castle, Norfolk (unpublished; John Hurst, *pers comm*).

Figure 161.10 is unique among the collection for its all over external covering of dark cobalt blue glaze and internal covering of clear greenish-blue lead glaze. The fabric is pale yellow and extremely friable. Dark blue glazes such as this were an occasional feature of 16th-century Netherlandish products. The same hue (known as *bleu Persan*) was extensively used at the French factory of Nevers in the mid 17th century and later at Lambeth in London (Britton 1986, fig 98).

Perhaps the most striking vessel is the tall, tapering, slender-necked bottle (Fig 159.8, inscribed A.BORAGINIS). The running foliage, the slanted and inscribed ribbon, and the debased guilloche frieze are virtually identical to a tall *albarello* from Antwerp dated to the middle of the 16th century (Drey 1978, pl 60A). A parallel, though not an exact

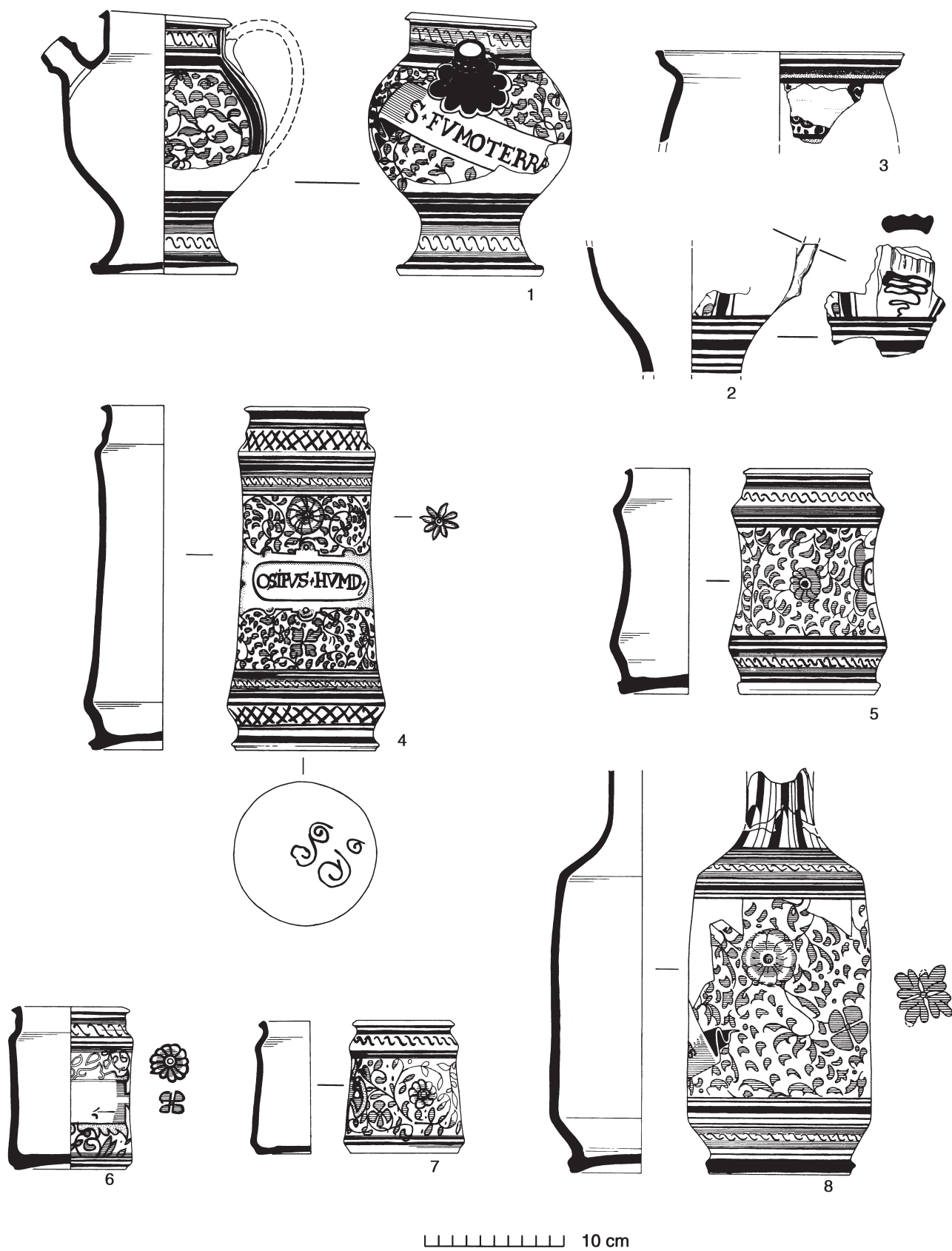

Fig 159 Tin-glazed wares: drug jars (nos 1-8). 1:4.

one, for the neck decoration of overlapping scale-like gadroons is seen on a Netherlands pharmaceutical jug dated 1579, and which has the same basic decorative scheme (Hurst *et al* 1986, pl 20,r). The bottle form itself is very unusual and is so far unparalleled. There is no evidence that it ever had a handle.

Figure 159.4 and 6-7 employ a limited use of ochre in the borders of the inscription cartouches and the last two have a pale blue-tinted tin glaze. Their flat bases may be a Netherlands feature. An interesting feature of Figure 159.4 is the spiral trial painting on the underside which parallels the stems of running foliage on the body. The rather stylised running foliage of Figure 161.11 is also found on early 17th-century dishes (eg Fig 162.24).

#### Pit group LWC VF2 (Stratified Group 19, c 1650)

The dating evidence and associated finds for this group have been discussed elsewhere (p 334). The most significant associated finds were eighteen clay tobacco pipes of c 1640-60. Profiles of seven largely complete drug jars and one dish fragment were recovered. These include the tallest drug jar in the collection (Fig 233.1), which illustrates a number of Netherlandish motifs including a running scroll of polychrome leaves and flowers or fruits, and the prominent blue and yellow split vine or fig leaf ultimately derived from Faenza *maiolica*. The execution, however, seems rather crude and the colours have run and blurred indicating that the vessel was fired upside-down. A shorter but otherwise identical vessel came from a pit complex described below (LWC C complex, see p 235). This had exactly the same firing defects and might even have come from the same kiln firing. Both jars date to the first half of the 17th century and are most likely Netherlandish. Figure 233.4 also displays some unusual firing defects. The colours, in fact, are a negative of those originally intended, so that the normally white tin-glazed background has somehow been reduced to a shiny black, inside and out, with blue decoration firing to a bluish-white. Traces of ochre decoration are faintly visible in the central quatrefoil. There are no indications that this vessel may have been burnt or that acidic groundwater somehow denatured its glaze while leaving the rest of the pit contents unscathed. It seems likely that the negative colouring was the result of a genuine kiln accident, but the result was not unattractive and evidently did not prevent the sale of the vessel. This jar is a Netherlands product. Its guilloche frieze is incised sgraffito-style so that originally it would have showed white against a blue background. The central design and its flanking tendrils closely resemble those found on a Netherlands *maiolica* bowl dated to c 1550-1600 (Hurst *et al* 1986, fig 55.169).

Figure 233.6, found almost whole, is covered on both sides with a bright turquoise blue-green glaze lending it a near-eastern character. It dates to c 1620-30 or slightly later and could be English or Netherlands. The remaining four drug jars from this group are Anglo-Netherlands products (Fig 233.2, 3, 5 & 7, this last found complete). These are typical of a class of late 16th-/early 17th-century drug jars decorated with a central geometric band, sometimes incorporating stylised vegetation motifs. The colours employed are blue, ochre yellow or brown, manganese purple or black, and sometimes green. They are tin-glazed both inside and out, but the internal glaze is normally of poorer quality with a pale bluish-green tinge. These are the commonest type of drug jar from the excavations and many can be closely

matched with the large collection from Norwich (Jennings 1981, fig 91.1451-60, fig 92 & fig 93.1476-82; see also Garner & Archer 1972, pl 2B & C). This is a common type in Stratified Group 20 (see below), and other examples from Lion Walk are illustrated in Figure 161.12-16. Size variation among these vessels is considerable, with rim diameters varying between 40 and 180 or 200 mm.

Geometric-band drug jars, or *albarelli*, were produced both in the Netherlands and England, but it is not usually possible to distinguish one source from the other, particularly if the designs are very simple. As a general observation, the more complex polychrome designs combined with a more elegant 'waisted' form tend to be earlier and so rather more likely to be Netherlandish. The central geometric (or vegetal) bands employ decoration schemes descended from both South and North Netherlands *maiolica*. Drug jars of 'waisted' form with simple geometric-band decoration (eg with chevrons as Fig 161.13 and Fig 233.7, or with leaves and tendrils as Fig 161.15) have been found in a kiln at Antwerp operated by Lucas Andries c 1560 (Dumortier & Veeckman 1994, fig 26 & pl 12). Drug jars with polychrome lentoid motifs, similar to Figure 233.3, have been found in a shipwreck off Alderney dated c 1594 (R Thomson, pers comm). Increasingly debased versions of these designs continued in production well into the 17th century. When there is associated dating evidence for the geometric-band type at Colchester, it is generally early to mid 17th century but, as mentioned above, the curation of some pieces by apothecaries could mean that they were already old when discarded.

#### Pit group LWC BF14 (Stratified Group 20, c 1650)

The dating evidence and associated finds in this group have been discussed elsewhere (p 337, Figs 234-9). A minimum of 20 tin-glazed apothecary vessels were recovered but the number could be as high as 25. The most impressive of these was a globular-bodied, spouted wet drug jar (Fig 159.1). Fragments of up to five very similar jars have been found in the Lion Walk area and at least one other such jar came from this group. Figure 159.2, from the lower part of an almost identical jar, came from surface clearance directly above this pit and may be part of this second vessel. Figure 159.1 is almost identical in shape and design to a polychrome spouted jar from Antwerp dated 1546 (Drey 1978, pl 60B). It is equally similar to another polychrome spouted jar from the Netherlands dated to 1579 (Hurst *et al* 1986, pl 20,l). The scrolled motif at the handle base of Figure 159.2 also occurs on a jug dated 1579 (*ibid*, pl 20,r). Our spouted jar differs from these in having blue decoration only. There is no doubt, however, that it is a Netherlands product of the second half of the 16th century.

Another globular or round-shouldered Anglo-Netherlands jar (Fig 159.3, from pit complex discussed below), was probably made to receive a lid. A thick tin glaze covers both inside and outside. The design is fragmentary and blurred but may include part of an inscription. Other tin-glazed vessels from Stratified Group 20 with a fairly certain Netherlands origin include Figure 234.4-5, almost certainly produced by the same potter. These are decorated in a similar fashion to Figure 159.1 and also date to the second half of the 16th century. At least two other drug jars of this date are represented by sherds from similar vessels, including one with an ochre and blue cartouche and fragmentary two-line inscription identical in style to Figure 159.6-7 in the



pit group described above. All the remaining drug jars from Stratified Group 20 (Fig 234.2, 3, 7-11) are of the Anglo-Netherlands geometric-band category discussed above. Sherds from three tin-glazed dishes came from the stratified group, of which Figure 234.1 was the most complete (see below p 237).

Lion Walk 'C' pit complex  
(LWC CF61/F42/F23/F19 & finds no 95; Fig 160)

As so many tin-glazed vessels illustrated in the typology came from a single complex of pits in Lion Walk Site C, it seems appropriate to give some account of their contexts. Discussion of the vessels themselves, however, is more easily treated under their typological headings since several vessel forms and several pits are involved. Intensive post-medieval pit-digging at this south-west end of Lion Walk has resulted in a highly complex succession of rubbish-pits whose relationships were not always clear, and in at least one instance (F42) the finds have suffered some slight modern contamination due to section collapse. Associated dating evidence in the form of coins and clay pipes was, like the pottery, subject to redeposition as is evident from the many cross-joins between sherds in different pits. In addition, some vessels may have had a long 'shelf life', and this combination of factors may explain why the associated dating evidence and the pottery are only broadly in agreement. The pit relationships and dating evidence are summarised in Figure 160.

A minimum of 24 substantially complete tin-glazed vessels was produced by the complex, as follows:

*Pit F61.* Drug jar (Fig 161.9).

*Pit 95* (upper fill of, or separate pit cutting late medieval pit F65). Drug jar (not illustrated, identical to Figure 233.1 but shorter); nine plates (including Fig 163.33-37). Other relevant fabrics include a Westerwald stoneware jug (Fig 196.3), a Metropolitan slipware jug (Fig 153.193), and a Border ware dish (Fig 155.7).

*Pit F42 (=F10).* Drug jars Figure 161.15-18, plus two others (not illustrated); one as Figure 233.3, the other with geometric decoration of interlaced chevrons; egg-shaped vase Figure 165.47; plate sherd joining the plate service in Pit 95.

*Pit F23.* Drug jar (Fig 161.13).

*Pit F19.* Drug jars, Figure 161.14 & 19; ovoid ?drug jar, Figure 159.3; sherds from one other drug jar. Other relevant fabrics include part of a Westerwald stoneware jug, Figure 196.3 (derived from Pit 95); a sherd from a polychrome Montelupo *tazza* (not illustrated).

### Drug jars (from the pit complex and other contexts)

Drug jars from the most important pit groups have been discussed earlier, along with similar material from some of the contexts under consideration here (see above pp 232-5). The remainder will now be considered.

One of the most highly decorated vessels in the collection is a large polychrome drug jar decorated with fruit (Fig 161.9, LWC CF61). The frieze is painted (from left to right) with pears, plums, a large flower and vine leaves, all with shaded tones and interspersed foliage. It has a pale cream fabric, tin-glazed on the outside, with a poorer-quality bluish-green tin glaze inside. Michael Archer considers this piece to date to the second half of the 16th century or just possibly the early 17th century. It is either Italian, probably Venetian, or a Netherlandish imitation of this style.

Figure 161.14-16, all from the above complex, belong to the general Anglo-Netherlands class and date to the first half of the 17th century. The Netherlands influence is particularly strong in the tendril fillers of Figure 161.15 which could be late 16th or early 17th century. From the same complex, Figure 161.17-19 are probably Dutch, of the first half of the 17th century. This shape and the satyr mask motif (Fig 166.17B-18B) first appeared in Holland during the

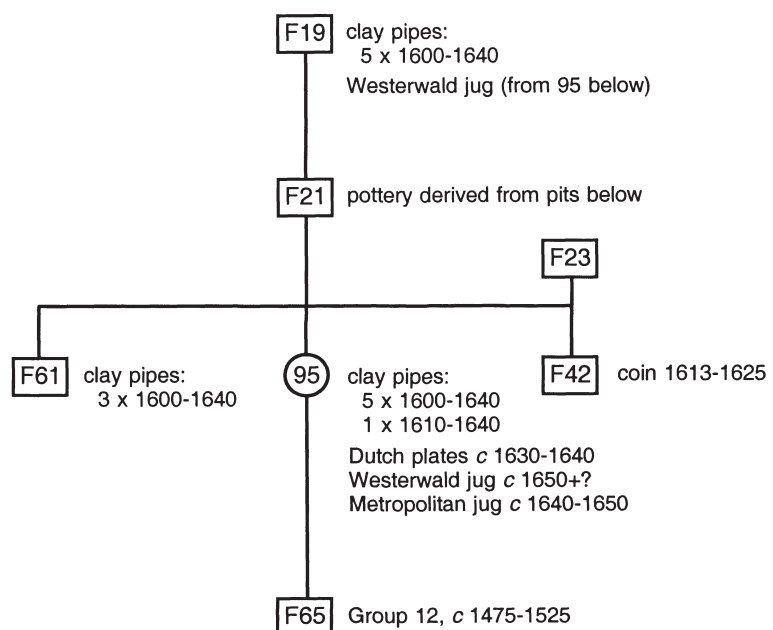

Fig 160 Tin-glazed wares: simplified matrix of Lion Walk 'C' post-medieval pit complex.

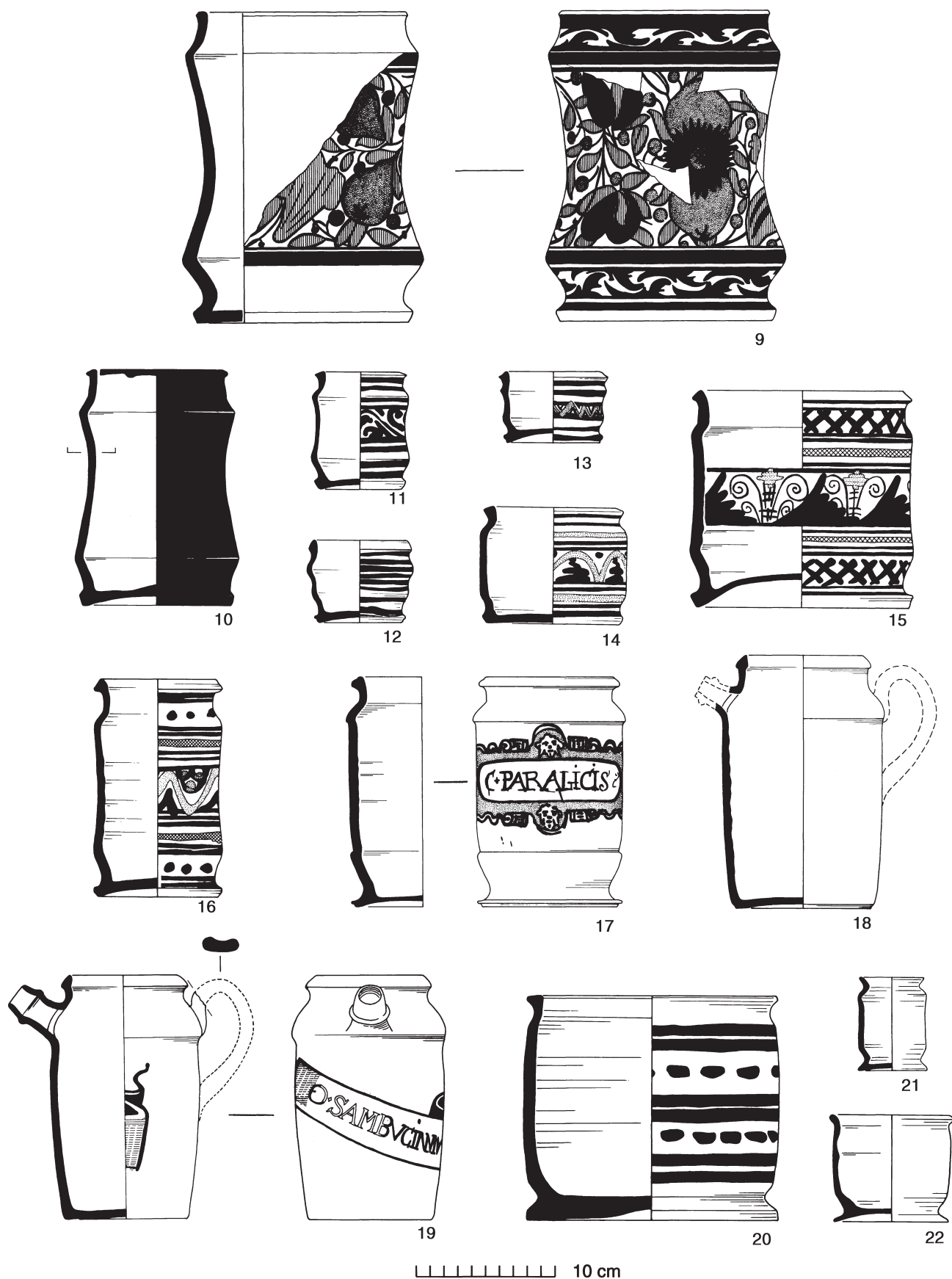

Fig 161 Tin-glazed wares: drug jars — Netherlandish (nos 9-11); Anglo-Netherlands (nos 12-19); English (nos 20-22) — all from Lion Walk (except no 21). 1:4.

earlier part of the century, but by the middle of the century they also occur in the repertoire of English tin-glazed drug jars (Drey 1978, 118, 132, pl 60C,D, & 67A,B). From other contexts, the latest types of drug jar are represented by large crudely-painted jars (Fig 161.20) and small plain jars (Fig 161.21-22; Fig 240.2, Stratified Group 21, c 1680-1700). These were common products of the later 17th- and 18th-century factories at London, particularly Lambeth.

## Dishes and plates

[Figs 162-4]

These account for slightly less than one-half of all tin-glazed vessels found. Of this figure, later 17th- and 18th-century plates with broad flanged rims comprise around 60%, while generally earlier foot-ring dishes or chargers account for the remainder. Chargers are sometimes referred to as 'blue dash chargers' on account of their rim decoration. These large dishes were produced in great quantities in England and Holland in the early 17th century, and English examples continued to be produced until c 1740 (Garner & Archer 1972, 7-12). They commonly have shallow, gently curved walls and a simple thickened rim, often internally grooved (Fig 162.23-28 & Fig 163.29-31, 38-39). Tin glaze is normally confined to the decorated inner surface while the underside is covered with a cheaper lead glaze. Chargers were purely decorative pieces and many of those illustrated here have a hole pierced through the foot-ring allowing them to be hung on the wall. On Figure 162.24 the piercing caused a large chip of foot-ring to become detached but this defect was subsequently glazed over. Most examples also display three equidistant scars on the inner face caused by stacking on tripod spurs during firing.

Dutch and English chargers of the earlier 17th century share much of the same decorative subject matter. On the basis of parallels, many of those illustrated here (Fig 162.23-28 & Fig 163.29) are most probably Dutch and belong to the first half of the 17th century, though an English origin for some cannot entirely be ruled out. Figure 162.23 with its bursting pomegranate design dates to c 1640 (*ibid*, pl 12), while Figure 162.24 could date to the start of century given its similarity to North Netherlands *maiolica*. The gadroon and chequer design of Figure 162.26 occurs throughout the first half of the 17th century. Figure 163.29 is painted with the artemisia leaf design sacred to the Chinese. It dates to c 1630-50 (Jennings 1981, fig 88.1412). Other Dutch dishes of the early 17th century include Figure 230.1 (Stratified Group 17, c 1625-50) and Figure 234.1 (Stratified Group 20, c 1650). Both are tin-glazed on both sides. As in the case of tin-glazed drug jars, there are many parallels with material from Norwich, much of which is ascribed a Dutch or Anglo-Netherlands origin (*ibid*, figs 84-8). Virtually all those chargers illustrated here and described above come from only two neighbouring pits of the late 17th/early 18th century and the early-mid 18th century (LWC AF3 & F6, respectively), and which lie beyond that area owned by the Great family of apothecaries. This implies that most of the chargers could have been up to a century old when discarded. Chargers from Stratified Group 21 (c 1680-1700, see pp 344-9) are mostly Anglo-Netherlands types (Fig 240.3-7, 9), and are similar to material found in London deposits of the Great Fire of 1666 (Alan Vince, pers comm). Figure 240.3-4 are decorated in a style derived from Ming

porcelain and which was current throughout the 17th century. Judging by their shape and the absence of an inside rim groove, these two are probably English and of the later 17th century. These designs, however, are almost identical in style to two largely complete chargers dated to the second quarter of the 17th century, from earlier excavations in the town (Hurst 1961a, figs 33-4).

Two unquestionably English chargers are Figure 163.38 and 39. Figure 163.39 is almost identical to an English portrait charger in Birmingham Museum which depicts King Charles II in full regalia with the date 1661 (Garner & Archer 1972, pl 19). On the fragment illustrated here, only the king's legs and torso survive but the orb, cross pendant and ermine-lined coat are clearly visible. The latest English charger shown here is Figure 163.38. Its form, the absence of a rim groove and its debased decoration are characteristically late 17th/early 18th century. An identical dish from the same site occurred in a pit with fifteen clay pipes of c 1700-40 (BKC VF185). Another characteristic often found on late English chargers is the use of tin glaze on both sides. This can also occur on early Dutch chargers but the shapes and decoration make confusion between the two unlikely. All over tin glaze occurs on at least one English charger fragment from the excavations, and this also has part of an inscription ('...NV B...') from a commemorative dish of William and Mary (c 1700, LWC B34; not illustrated). Plates, with flat or occasionally foot-ring bases and broad flanged rims, are more often decorated than plain. Apart from those occurring in the stratified groups, which are fully illustrated, only a selection of the most complete and significant plates has been illustrated here. Many other highly decorated but fragmentary 18th-century plates have not been illustrated in this volume, but the range of decoration present is in many cases closely paralleled by Dutch and English plates found at Norwich (Jennings 1981, fig 81 *passim*).

An important group of at least nine plates came from a single pit (LWC C95) whose associations in the LWC C complex have already been considered (see above p 235). These are of Dutch workmanship and date to c 1630-40. Six of the most complete plates have been illustrated (Fig 163.33-37 & Fig 164e-f). The two remaining plates are represented only by rim fragments with very similar designs. As all nine are so similar in style and of identical form they can be regarded as parts of the same 'service' of plates, perhaps broken simultaneously in a most unfortunate accident (perhaps the siege of 1648?). They all have similar geometric border designs and a central roundel, though each varies slightly. The subject matter in the roundels is: ships in four (Fig 163.33 & Fig 164.a-c); a mermaid in one (Fig 164.d); an exotic scene of birds, insects and flowers in Chinese Wan Li style (Fig 164.e); and a central rosette (Fig 164.f) which is characteristically Dutch. The border decoration on Figure 164.e is exactly paralleled by a similar plate sherd in the Rijksmuseum, Amsterdam which bears the date 1638 (Hudig 1929, pl 72). A single sherd of Figure 163.33 was found in an adjacent pit (see above, LWC CF42) which may predate the plate pit. Another sherd from Figure 164.b was found approximately 65 m to the north-east in a later cellar on the other side of the road (LWC BF70).

Several sherds from the above plate service ended up in the latest pit in the LWC C complex (LWC CF19) which also produced the plate Figure 163.32. This plate differs from the others in having a short foot-ring and a Ming-style

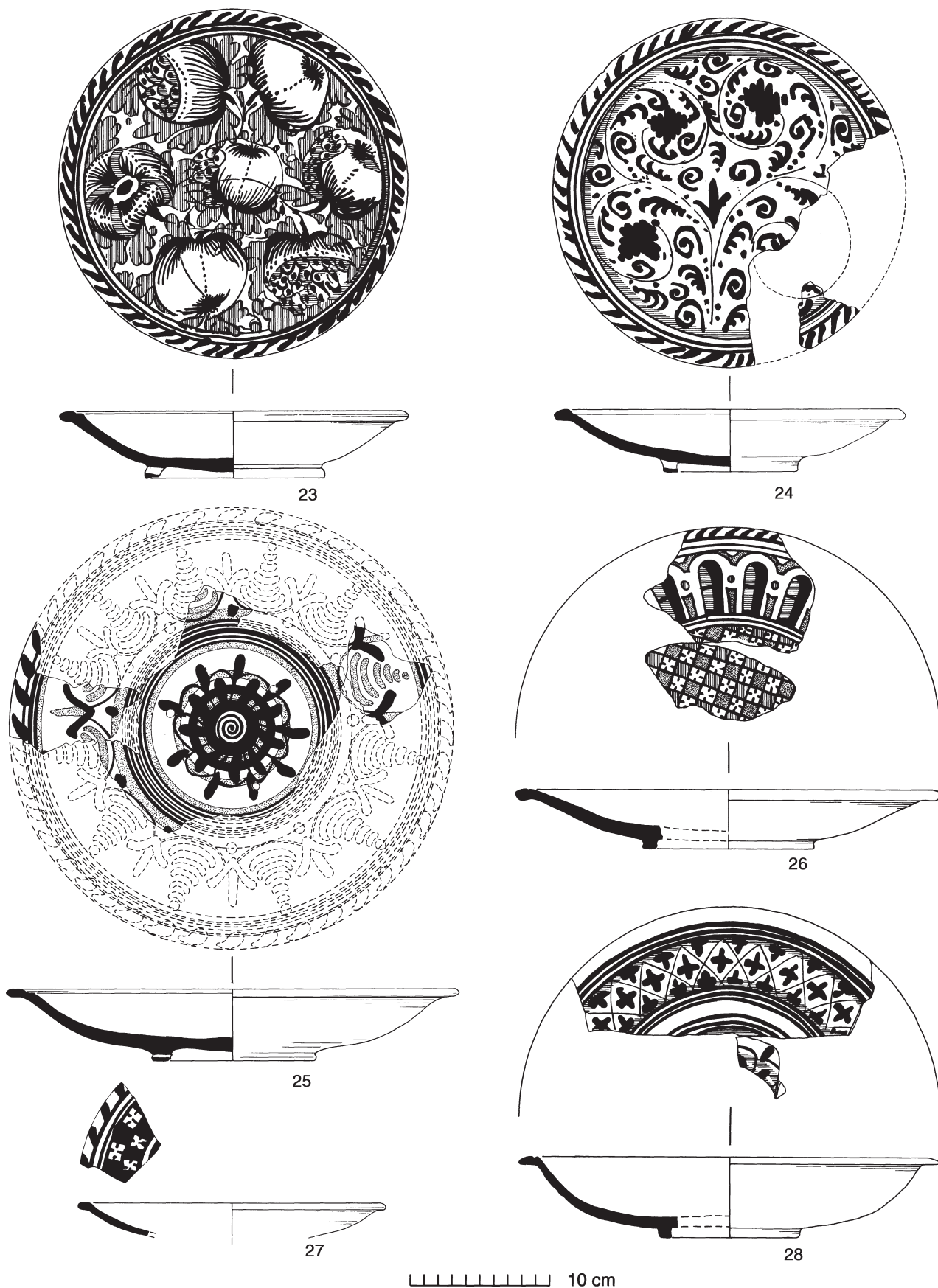

Fig 162 Tin-glazed wares: Anglo-Netherlands dishes or 'chargers' from Lion Walk (nos 23-28). 1:4.



Fig 163 Tin-glazed wares: Anglo-Netherlands dishes or 'chargers' (nos 29-31); Dutch plates or dishes c 1630-40, all except no 32 from LWC C95 (nos 33-37); English dishes or 'chargers' (nos 38-39); saucer (no 40); Dutch dish (no 41).

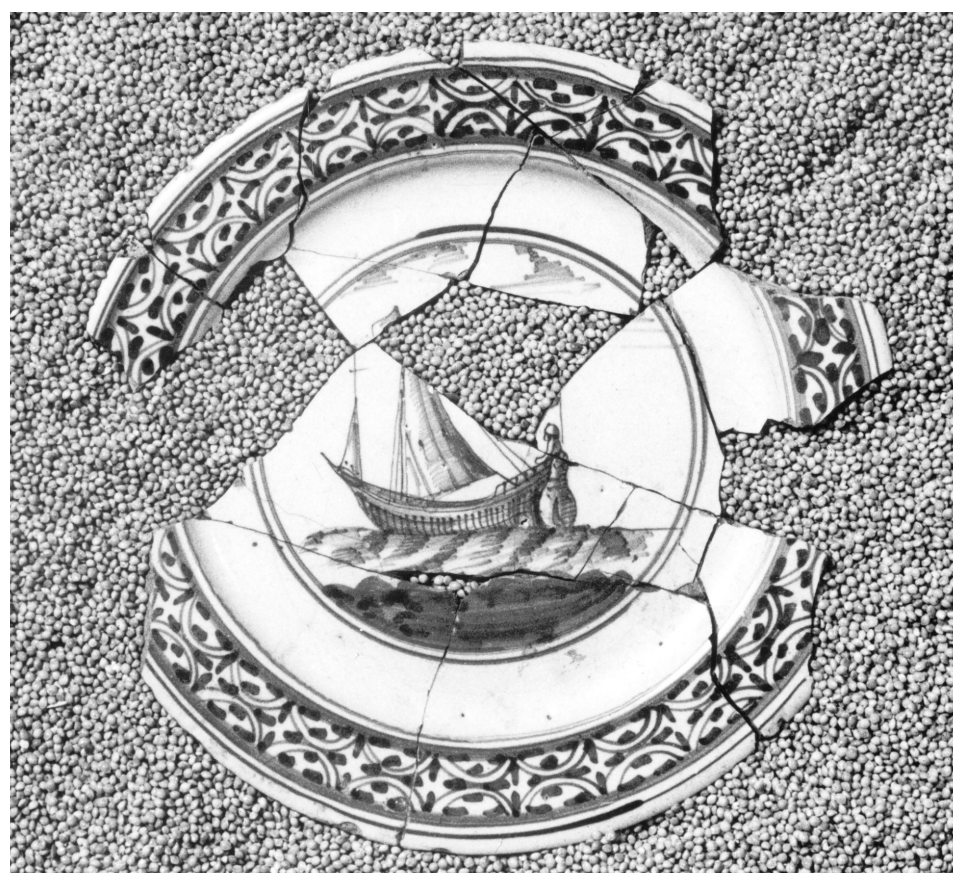

Fig 164a-b Tin-glazed wares: two Dutch plates c 1630-40, part of a set of at least nine plates from a pit on Lion Walk (LWC C95) — a - no 33, b - no 37 (diameters approx 200 mm).

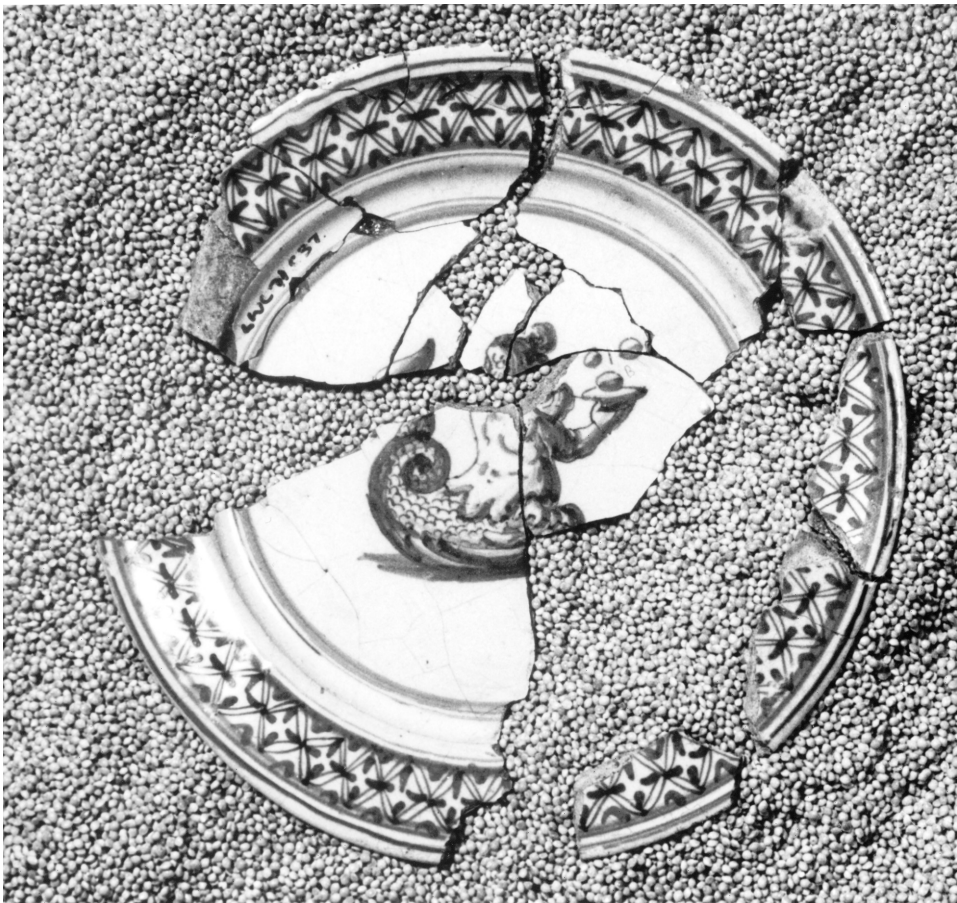
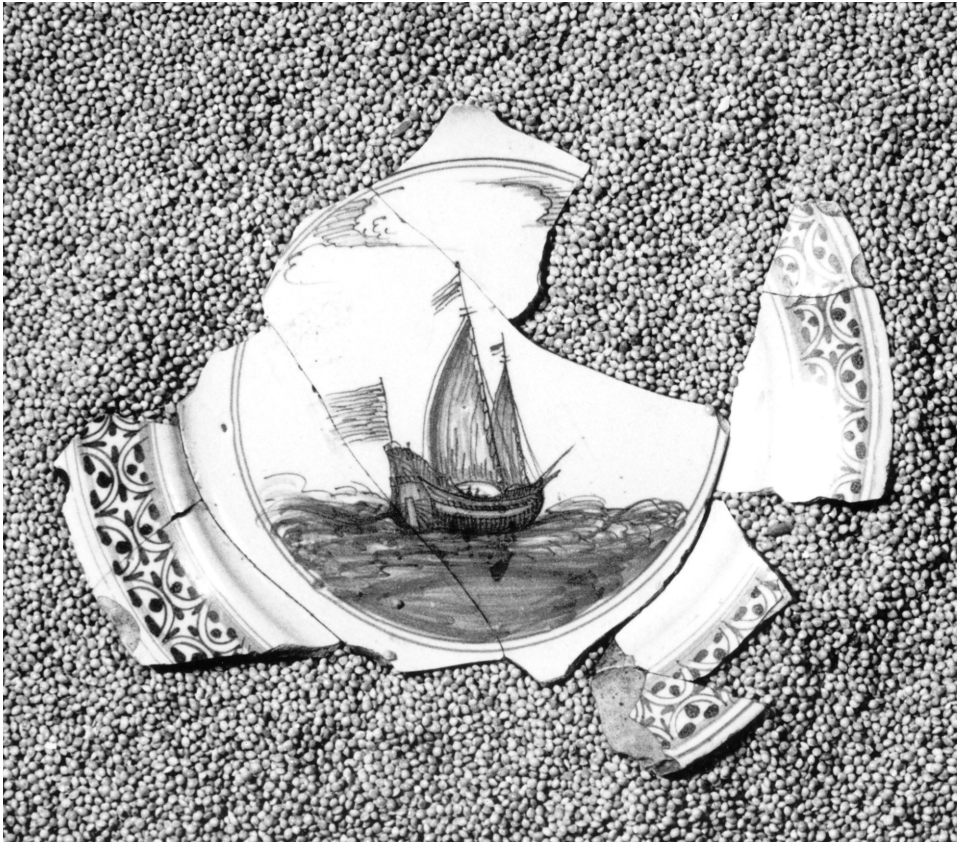

Fig 164c-d Tin-glazed wares: two Dutch plates c 1630-40, part of a set of at least nine plates from a pit on Lion Walk (LWC C95) — c - uncatalogued, d - no 36 (diameters approx 200 mm).

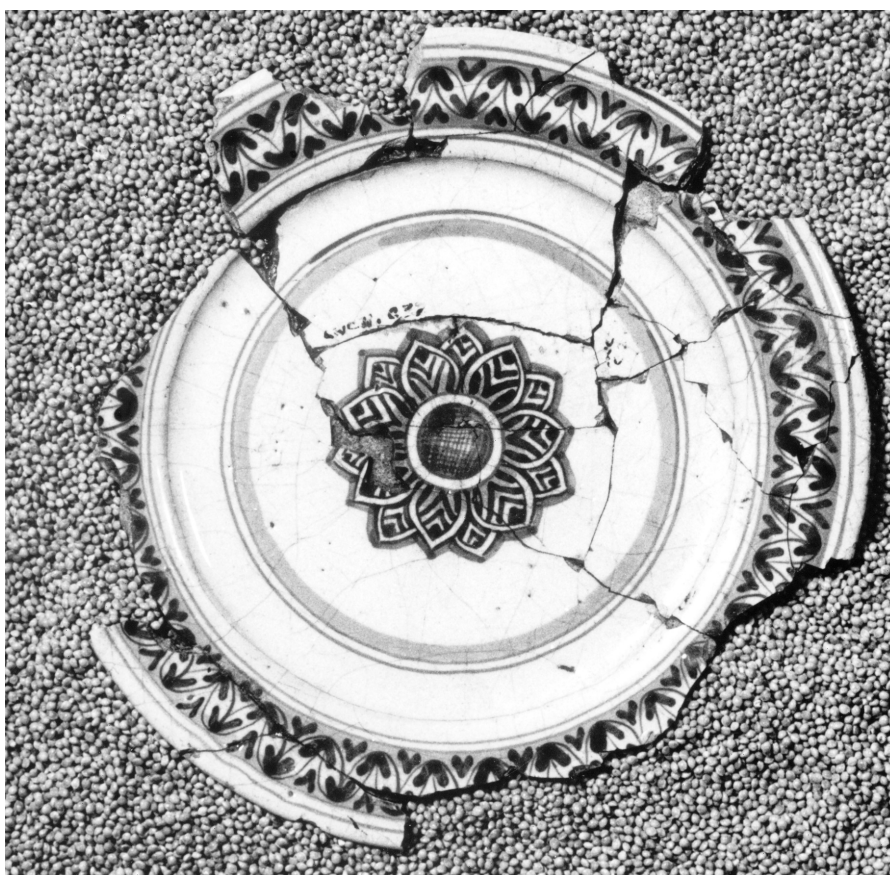

Fig 164e-f Tin-glazed wares: two Dutch plates c 1630-40, part of a set of at least nine plates from a pit on Lion Walk (LWC C95) — e - no 35, f - no 34 (diameters approx 200 mm).



border design and decoration on the underside. The fragmentary central rosette, however, is identical to that of Figure 164.f in the plate service. From a different context, Figure 163.41 is probably Dutch and dates to c 1730. Many Dutch plates were made specifically for the East Anglian market. Ray illustrates an example made for Martin and Elizabeth Hopkins of Wivenhoe (a small port near Colchester) and dated 1748 (Ray 1968, pl 14, no 44). An attractive Chinese-style saucer (Fig 163.40), probably English c 1700, has a *café au lait* rim and several roundels which appear to show a man in a tunic holding or juggling a dish or a hat in each hand. From the same context as the latter (LWC VF1, c 1740-1840) came a number of blue-tinted plates with Chinese-style landscapes typical of the London potteries c 1760-70 (not illustrated; cf Garner & Archer 1972, pl 85A). Rarer dish and plate forms include a fluted dish fragment from Stratified Group 21 (Fig 240.11). These had a foot-ring and were made both in England and Holland during the 17th century, although this example is probably Dutch and of the second half of the 17th century. Two complete profiles of this form were found on the Angel Yard site (material awaiting study; cf Jennings 1981, fig 90.1437). An octagonal plate rim with blue floral decoration came from another site (LWC C82, not illustrated).

## Bowls

Very few examples from the Netherlands were found. All bowls illustrated here appear to be English. The small plain hemispherical foot-ring bowls or cups (Fig 165.42-43) are from 17th-century contexts. Figure 165.42 and a small cup from Stratified Group 22 (Fig 245.7, c 1730-40) both copy a common Chinese porcelain form. A larger thin-walled bowl (Fig 165.44) is decorated internally with blue star designs which are also known on a Lambeth mug of c 1680 (Garner & Archer 1972, pl 28A). Porringers or 'bleeding bowls', with moulded and perforated handles and sometimes with concentric decoration, are common in 17th- and early 18th-century contexts. Figure 165.45 is English whereas Figure 240.10 (Stratified Group 21, c 1680-1700), with its heavier, less delicate handle, is likely to be Dutch.

Large hemispherical 'punch bowls' such as Figure 165.46 were made from the late 17th century and throughout much of the following century at many British factories. This example is probably a London or Bristol product of c 1680 or a little later (found with clay pipes of c 1700-40).

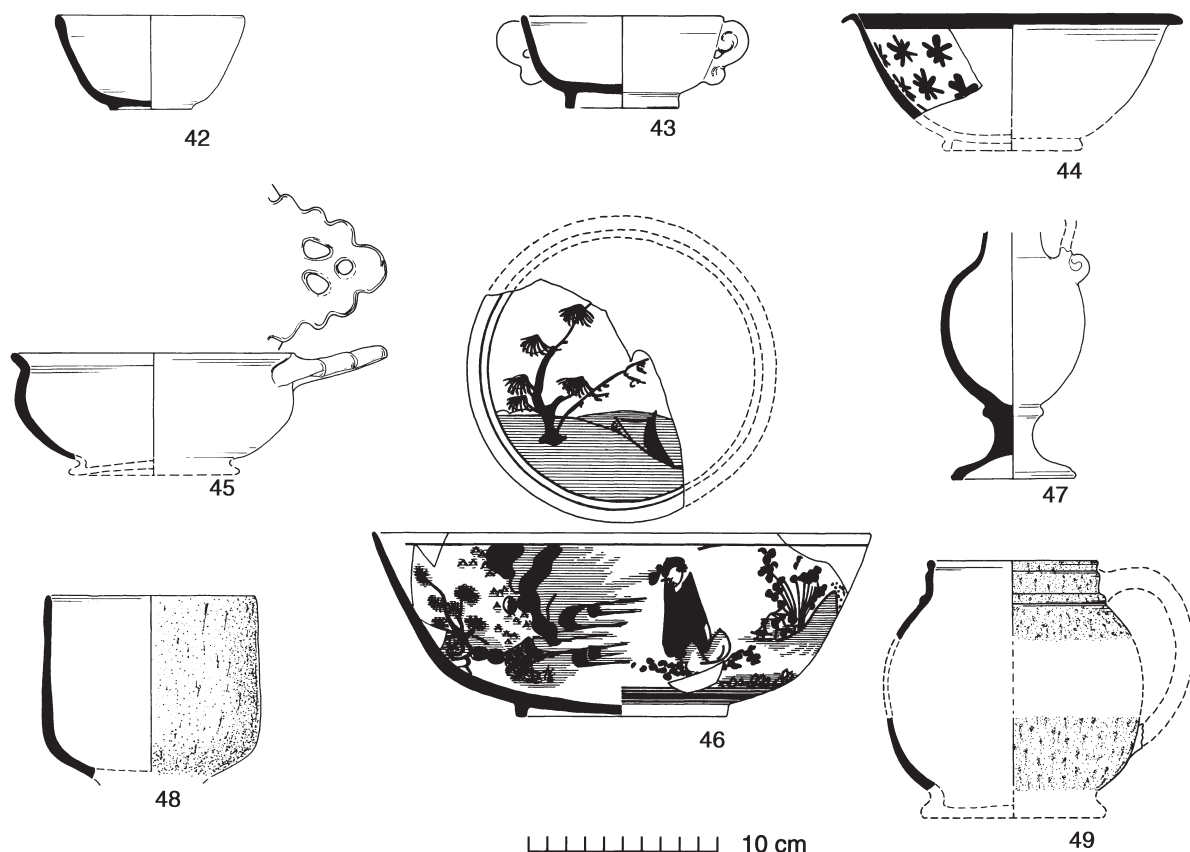

Fig 165 Tin-glazed wares: small bowls or cups (nos 42-43); small bowl (no 44); porringer (no 45); punch bowl (no 46); vase (no 47); purple-speckled goblet or cup (no 48); purple-speckled drinking jug (no 49). 1:4.

### Other forms

Tin-glazed drinking jugs (Fig 165.49) are relatively uncommon. All are purple-speckled externally. Figure 165.48, also with an external purple speckle, is probably from a goblet or chalice with a pedestal base. A few purple-speckled sherds are found in mid 17th-century contexts; one sherd was found inside a buried redware jar which also contained a token of c 1660 (MID CF104). Most purple-speckled vessels, however, came from late 17th-century and 18th-century contexts. Figure 165.48, for instance, was found with a clay pipe of 1680-1710 and a coin of 1699-1701. An unusual vase with an egg-shaped body and a scroll handle (Fig 165.47) came from the pit complex described above. The neck has a tiny perforation which may be intentional. Fragments of at least three plain chamberpots were found (not illustrated; as Jennings 1981, fig 97.1524). Another small sherd (LWC G20, not illustrated) is probably from the corner of a square 'salt' with a moulded cornice decorated with external horizontal blue lines and blue spots on top.

### The pharmaceutical inscriptions

Several drug jars from the Lion Walk area carry inscriptions listing their medicinal contents. Eleven of these are complete enough to be read or inferred. The inscribed ribbons and cartouches are here collected together and unravelled for better comparison. All the inscriptions are in Latin, pseudo-Latin or Italian. Interpretations given here are based on the glossary of apothecary jar inscriptions given in Drey (1978, 179-238).

Fig 166.1B: globular spouted jar  
 Inscription: S•FVMOTERRA  
 Equivalent to: *Siropo di Fumoterra*  
 Translation: syrup of fumitory (*Fumaria officinalis*)

Fig 166.8B: tall bottle  
 Inscription: A•BORAGINIS  
 Equivalent to: *Acqua di Boragine*  
 Translation: water of borage (*Borago officinalis*)



Fig 166 Tin-glazed wares: the pharmaceutical inscriptions from the Netherlandish and Anglo-Netherlands drug jars (numbered as catalogue entries except nos 50-51 illustrated in Stratified Group 20). 1:4.

Fig 166.50: small drug jar  
 Inscription: ?T•D•MYRRA  
 Equivalent to: *Tinctura di Myrrha*  
 Translation: tincture of myrrh (*Commiphora myrrha*)

Fig 166.51: small drug jar  
 Inscription: P•AGGREGATINA  
 Equivalent to: *Pilulae Aggregativae*  
 Translation: purgative pills  
 Made from aloes, agaric, colocynth, larch, myrobalans, rhubarb, scammony, turpeth root and other ingredients. Used in treatment of headaches and gastric pains (Drey 1978, 183).

Fig 166.19B: spouted jar  
 Inscription: O•(SAM)BVCINVM  
 Equivalent to: *Oleum Sambucinum*  
 Translation: oil of elderflowers (*Sambucus nigra*)  
 A linament of elderflowers boiled in olive oil.

Fig 166.4B: tall drug jar  
 Inscription: OSIPVS•HVMD  
 Equivalent to: *Oesyplus Humida*  
 Translation: wool fat (lanolin)

Fig 166.5B: drug jar  
 Inscription: CASSIA•M(AND)A  
 Equivalent to: *Cassia. Mandorla?*  
 Translation: Cassia and almonds?  
 Possibly a mixture of either cassia (*Cassia fistula*) or cassia cinnamon (*Cinnamomum cassia*) and almonds.

Fig 166.6B: small drug jar  
 Inscription: .....  
 ARB(A).....  
 Translation: uncertain  
 Possibly includes (RHUB)ARB(ARUM), ie rhubarb (*Rheum*).

Fig 166.7B: small drug jar  
 Inscription: DIA•M(AR)  
 CARI•CAL  
 Translation: uncertain  
 DIA means 'made from'. Several substances and herbs begin with the letters MAR, one possibility is *Marum*, a name applied to the labiate plants which includes cat thyme (*Teucrium marum*). CARI may derive from dried fig (*Ficus carica*) or cloves (*Cariophylli*). CAL could also derive from several plants including common calamint (*Calamintha officinalis*), caltrop (*Calcatrepola*), garden marigold (*Calendula officinalis*) and other medicinal substances.

Fig 166.17B: drug jar  
 Inscription: C•PARALICIS  
 Equivalent to: *Conserva* or *Compositum Paralysis*  
 Translation: conserve or composition of cowslip (*Primula officinalis*)  
 Used in treatment of nervous disorders.

Fig 166.18B: spouted jar  
 Inscription: O•VIOLARVM  
 Equivalent to: *Oleum Violarum*  
 Translation: oil of violets.

### North Devon gravel-tempered ware (Fabric 56)

[Fig 167]  
 Weight: 0.025 kg  
 Number of sherds: 1  
 EVEs: 0.07

There is a single sherd from a straight-sided bowl in this ware (Fig 167.1; identification confirmed by Cathy O'Mahoney). It has a pale orange-pink outer surface and a

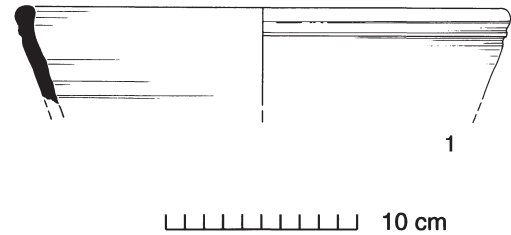

Fig 167 North Devon gravel-tempered ware: bowl (no 1). 1:4.

reduced pale grey inner surface. The fabric has a very coarse texture composed of rock fragments, up to 3 mm across, scattered through a finely micaceous matrix. These include very coarse angular quartz and either calcite or feldspar crystals, coarse red iron oxide and a black glassy inclusion, probably amphibole or pyroxene. There are also rock fragments perhaps of metamorphic origin. The inside is covered with a reduced glossy greenish glaze which extends outside over the grooved rim.

North Devon gravel-tempered ware is present in Dissolution deposits (c 1536-50) at St Nicholas' Priory in Exeter, but production of bowls in quantity seems to have occurred only after c 1600 (Allan 1984, 131-2). Outside of the south-west peninsula most of the export trade had a westerly orientation, to Wales, Ireland and even America. It is unusual to find the ware so far east of its source, although small quantities have turned up in London (Alan Vince, pers comm). The Colchester sherd, however, is the only example known from Essex. Stray items of Devon wares might have found their way eastwards on boats transporting Devon pipe clay to centres of tobacco-pipe manufacture, which included Colchester (CAR 5, 62-6). The shipment of tobacco-pipe clay from Poole (Dorset) to Colchester is recorded in 1685 (Cockerill & Woodward 1975, 8).

The sherd came from a large, early to mid 18th-century pit (LWC AF6: clay tobacco pipes, c 1700-1740; with Staffordshire white stoneware). There is a close parallel for this form at Exeter from a context of c 1690-1720 (Allan 1984, fig 128.2865).

### English stonewares (Fabric 45)

[Fig 168]  
 Weight: 9.735 kg  
 Number of sherds: 294\*  
 EVEs: 3.90\*

This section is primarily concerned with the coarse brown salt-glazed stonewares produced in London between the mid or late 17th century and c 1800. It thus excludes the large quantities of 'modern' stoneware vessels of the 19th and early 20th century, such as blacking bottles, etc (Fabric 45M). It also excludes the distinctive Nottingham/Derby type of lustrous brown stoneware with rouletted decoration which, although having late 17th-century origins, is represented in

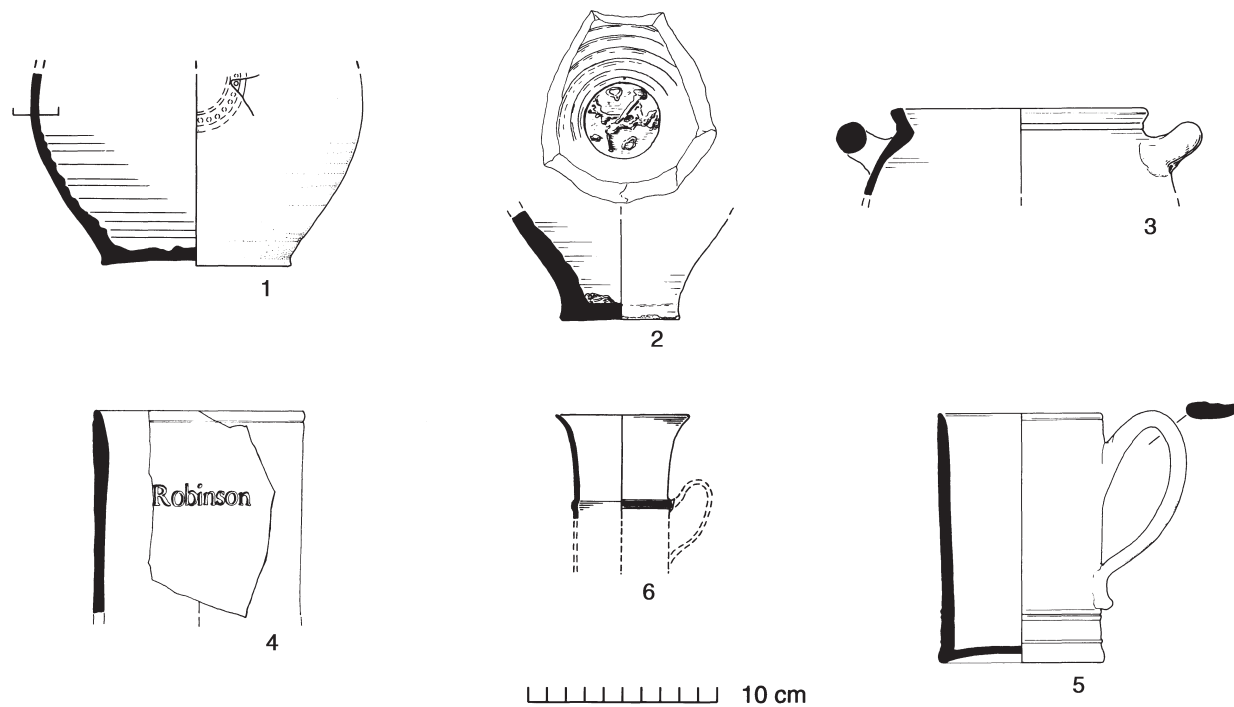

Fig 168 English stoneware: bottles or 'bellarmines' (nos 1-2; no 2 is a 'witch bottle' with bent pins and nails in base); storage jar (no 3); London stoneware tankards (nos 4 & 5); Staffordshire-type brown stoneware capuchine (no 6). 1:4.

Colchester mostly by large 19th-century mixing bowls. A few brown tankards of Midlands origin are however considered.

Until quite recently the earliest known English stonewares were those produced by John Dwight at his pottery in Fulham from 1671 or 1672 onwards (Oswald *et al* 1982, 24-37). However, recent excavations at Woolwich have shown that salt-glazed stonewares were produced here in a kiln built c 1660 or slightly earlier, thus predating Dwight's patent of 1672 (Pryor & Blockley 1978).

Late *Bartmann* jugs or 'bellarmine' bottles were produced both at Woolwich and Fulham in the mid and late 17th century respectively, and in the 18th century plain brown stoneware bottles of similar shape were produced at Fulham and many other London potteries along the Thames. Stylistically the London bellarmines are difficult to distinguish from their German prototypes, which they copy closely. However, there are subtle differences between the applied medallions occurring on the Woolwich bellarmines (*ibid*, figs 10.32-5, 11.36 & 40.2) and those commonly occurring on imported German types (see Fig 194.15-22), while the Fulham medallions are quite distinctive (Christophers *et al* 1977, 5, figs 1-12).

Dwight's Fulham stonewares, and most other London brown stonewares, were made from pale-firing Dorset ball clay (Oswald *et al* 1982, 28). This generally allows London stoneware to be distinguished from the darker, harder German bellarmines but even some undoubted German examples sometimes have a pale-firing fabric. Although there are many salt-glazed 'bellarmines' from the Colchester excavations (Fig 194.15-22), none has a distinctive Woolwich or Fulham medallion and all the medallions are of common Cologne/Frechen type. It would appear therefore that the vast majority of Colchester's brown salt-glazed

'bellarmines' are German imports, probably imported via Holland or redistributed from London, and that indisputable examples of London 'bellarmines' in the town have yet to be recognised.

English stoneware comprised only 1.6% (EVEs) of the Period 5.3 assemblage (c 1680/1700 onwards), compared to the 4.7% comprised by imported Frechen and Westerswald stonewares. Of the minimum count of around 71 recognisable English stoneware forms from the excavations, bottles (including 'bellarmines') comprise 47%, mugs or tankards comprise 51% and jars 2%. The figure for bottles, however, could include some German examples and so could be lower, whereas that for tankards, a distinctive English form, is at least the figure given.

Only a few possible London stoneware 'bellarmines' (as opposed to plain bottles) have been recognised from the excavations (Fig 168.1-2), but only on the basis of their pale cream-firing ball-clay fabric and late contexts. Figure 168.1, which retains a trace of a medallion, is from Stratified Group 21 (c 1680-1700). Figure 168.2 has been re-used as a 'witch bottle'. These frequently contain bent pins, nails, fingernail clippings and human hair, and were usually buried under thresholds or placed into walls, etc, to ward off evil spirits or combat curses. Most of these date from the second half of the 17th century and are particularly common in East Anglia (Merrifield 1987, 163-75). The example from Balkerne Lane shown here is the first 'witch bottle' to be recognised from the town (but see also Fig 194.16), and it contains a corroded mess in the base containing at least one bent copper-alloy pin and two bent nails. Unfortunately the context of this example is confused, but it comes from a site alongside the town wall where a row of houses stood until some decades ago and which produced only 18th-century and later pottery.

The majority of 'bellarmine'-like forms from the excavations must represent the plainer form of London stoneware bottle which, unlike the German imports, commonly had a large beaded or flattened beaded rim (Oswald *et al* 1982, pl 20.1). Curiously, extremely few such rims were recovered and there are no substantial profiles of this form. It is curious then that the majority of the several dozens of 'bellarmine' and bottles in Colchester Museum are of exactly this plain bottle type. These were probably recovered during Victorian building operations in the town.

Only two English stoneware jars were found including Figure 168.3, a loop-handled jar in a pale buff fabric with a grey salt-glazed exterior. This appears to be a direct copy of a Westerwald stoneware form of which originals and an English copy are known from Norwich (Jennings 1981, fig 52.861). Figure 168.3 was found with fifteen clay tobacco-pipes of c 1700-1740 and fragments of at least two finely-reebed brown Nottingham stoneware tankards. The other jar is probably a baluster-shaped London stoneware storage jar of the first half of the 18th century (Oswald *et al* 1982, pl 22 middle).

London stoneware tankards (Fig 168.4-5) were produced at a number of potteries on the south bank of the Thames. The earliest dated example is 1704 (*ibid*, pl 13), and examples ranging between 1713 and 1775 are fairly common (Askey 1981, 41-6). Often the top half was dipped in an iron wash while the bottom half remained grey. From c 1760, lettering on tankards was made by impressing the clay with metal-type characters (Fig 168.4), a practice which continued until the 1790s. A very similar but clearly separate tankard from the same context as the latter has the partial metal-type inscription 'Rob.t...' (Rob.t Robinson?). Fragments of applied plaques are present on some tankards. Several Colchester examples are impressed with the crowned 'WR' excise mark used from 1700 until its repeal in 1876 (*ibid*, 41).

Of the more interesting London stoneware tankards in the reserve collection of Colchester Museum, the following details are recorded:

Tall, iron-dipped tankard with 'AR' excise mark and freehand inscription 'Joseph Croswell att the Goldenfleece Coulchester 1710' (CM 147.1976). Found in the River Colne. The 'Fleece' stood in Colchester's Head Street.

Tankard with metal-type inscription 'Moor Colchester', below a plaque of Saint George and the dragon, possibly an allusion to the old 'George Hotel' which stands in the High Street (CM 3862.1919).

Tankard with freehand inscription 'Thos. Shipton 1756' (CM 120.1977).

There is one example from the excavations of a very finely lathe-turned *capuchine* of the early 18th century in iron-washed stoneware (Fig 168.6), probably from Staffordshire.

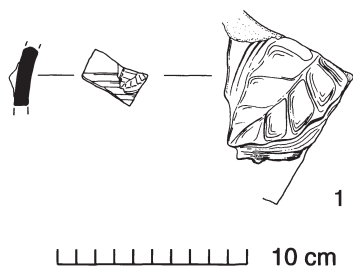

Fig 169 Wrotham slipware: jug or jar sherd with applied pipeclay decoration (no 1). 1:4; decoration detail at 1:1.

## Wrotham slipware (Fabric 40D)

[Fig 169]

Weight: 0.010 kg

Number of sherds: 1

A small sherd of this ware from the wall of a jar or jug has been identified (Fig 169.1). The fabric is the same as the standard post-medieval red earthenware fabric found in Essex (Fabric 40), a hard sandy oxidised ware. Both sides are covered with a clear glossy glaze and the outer surface has a band of horizontal grooving suggesting that the sherd comes from the shoulder area of the vessel. The outside is decorated with a sprigged or stamped pad in white pipeclay in the form of a ?leaf shaped rather like a pine cone in high relief and with a triangular cross-section. It came from a layer (LWC B27) overlying Stratified Group 20 (c 1650) and sharing many cross-joins with the latter context from which it may be derived. However, there were no similarly decorated sherds in Stratified Group 20 itself.

Sprigged decoration of this sort is not characteristic of Metropolitan slipware (ie from Harlow, Loughton and Stock), where the slip is simply trailed on, but it is a distinctive and recurrent feature of Wrotham slipware produced near Maidstone in Kent. Wrotham slipware survives in several museum collections mainly in the form of elaborately decorated cups and mugs which were sometimes signed and dated by the potter. Dated Wrotham vessels range from 1612 to 1739 (Kiddell 1954; Ashdown 1968). There is a large collection of this ware in the Fitzwilliam Museum, Cambridge. Applied prunt or sprigged decoration, very similar to that on the sherd from Lion Walk shown here, occurs on several Wrotham vessels at Cambridge but seems most closely matched on two vessels dated 1656 and 1668 made by the potter Henry Ifield. These dates would also fit with the date of c 1650, or shortly afterwards, suggested by the context of the Lion Walk sherd, whether it was made by this potter or not.

Despite its celebrated status among ceramicists and art historians, Wrotham slipware is known almost entirely from museum collections and heirlooms. Remarkably few examples of the ware have turned up on excavations, even at Wrotham itself where coarsewares appear to have been the mainstay of the industry (Ashdown 1968). Excavated specimens of the slipware are currently known only from Maidstone (*ibid*, 16) and the Marlowe Car Park site in Canterbury (unpublished), but it is possible that some pieces also occur in London (Nenk *et al*, in prep). The Lion Walk vessel is the first example of Wrotham slipware found in Essex and is further away from Wrotham than any example yet excavated. It is unusual, however, that the Lion Walk sherd is from a jar or jug rather than a drinking vessel (the thickness and diameter seem too large to be the latter), but jars and jugs in this ware are uncommon. It could be that the Lion Walk vessel represents a less elaborate form than the commemorative drinking vessels and was thus less well-cared by its owners. In the 17th century, fuller's earth (and wool) for the textile industry were supplied direct to Colchester from Rochester and Faversham in Kent (see p 19), and it could be that Wrotham slipware and perhaps even the coarsewares were either traded or more casually circulated during these exchanges.

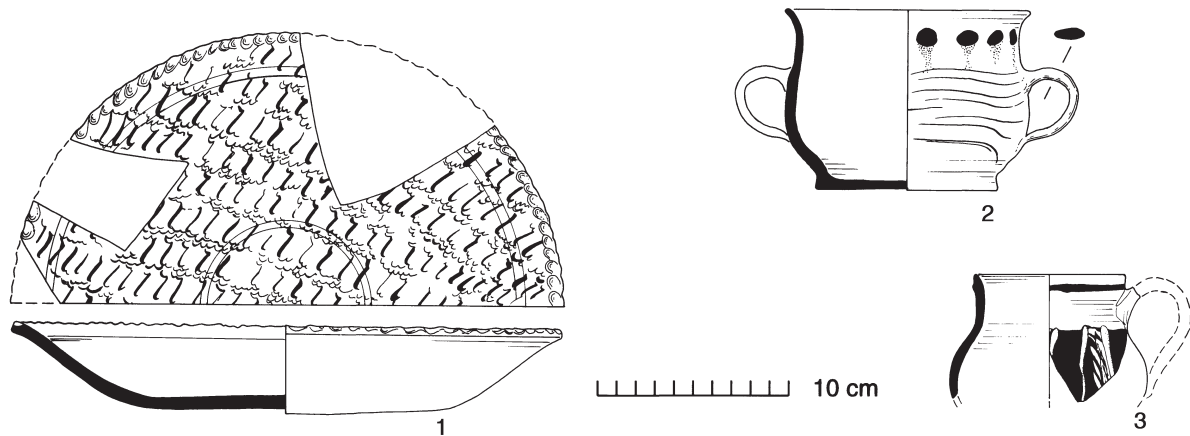

Fig 170 Staffordshire-type slipware: press-moulded dish with combed decoration (no 1); porringer (no 2); cup (no 3). 1:4.

### Staffordshire-type slipware (Fabric 50)

[Fig 170]  
 Weight: 7.865 kg  
 Number of sherds: 233\*  
 EVEs: 2.85\*

Press-moulded slipware dishes were produced in Staffordshire from the second half of the 17th century and throughout the 18th century (Celoria & Kelly 1973; Barker 1993). In other centres, press-moulded dishes continued in production well into the 19th century, though perhaps by now in much smaller quantities. At Ipswich (only eighteen miles north of Colchester), William Balaam was producing sub-rectangular Staffordshire-type slipware dishes at his Rope Lane factory, perhaps as late as 1883 when he is listed in *Kelly's Directory*. These sometimes bore his stamp on the reverse (Godden 1980, pl 30). Wheel-thrown slip-decorated hollow-wares were also produced in Staffordshire and Bristol (Barton 1964, 194). It is likely that the majority of Staffordshire-type slipwares from Colchester are actually from Staffordshire, particularly as agents for the Staffordshire potteries resided in the town in the 18th century (see p 251).

The great majority of Staffordshire-type slipware vessels from the Colchester excavations have a fairly fine buff or off-white fabric. Press-moulded dishes are covered internally with a brown slip, over which parallel bands of cream slip were trailed and then combed or feathered into the characteristic designs resembling Bakewell tarts (Fig 170.1). The interior only is covered with a clear glaze. On hollow-wares brown slip usually covers only the external globular body of the vessel which is then trailed with white slip and then combed. Details on the upper part of the vessel, such as blobs or bands, are carried out in brown slip trailed directly on to the pale buff fabric (Fig 170.2-3). The whole vessel is then covered with a clear glaze down to the base. Combed or feathered decoration on hollow-wares occurs from the late 17th century onwards, whereas combed dishes

seem only to date from the early 18th century (Barker 1993, 16, 18).

Press-moulded dishes are by far the commonest form represented on the excavations. All of these have plain bevelled rims with typical piecrust decoration. The circular dishes vary in diameter from 180 to 350 mm with sizes around 290 and 330 mm being commonest. There are also many large sub-rectangular dishes whose full size cannot be properly gauged. The combed decoration on Figure 170.1 is fairly typical of dishes from 18th-century contexts; other designs do occur but these have not been illustrated. Only one sherd is decorated with an impressed and studded annular design in 17th-century style (not illustrated; STG 146). Some large rectangular dishes occur in a sandier brick-red fabric and the evidence suggests these are 19th century.

Porringers (Fig 170.2) are the next commonest form, with around sixteen vessels represented. These are followed by globular cups or mugs (Fig 170.3), with only two examples represented.

Staffordshire-type slipware comprised only 0.17% of the Period 5.3 assemblage (c 1680/1700 onwards, but mainly c 1680/1700-50). There are no examples of Staffordshire-type slipware from early or mid 17th-century contexts in Colchester. It first appears in late 17th- or early 18th-century contexts — eg a ?porringer (Fig 241.37) from Stratified Group 22 (c 1680-1700) and a dish fragment (Fig 245.9) in Stratified Group 2 (c 1730-40) — and many other contexts of a similar date. Press-moulded dishes are more common in later 18th- and 19th-century contexts and these tend to be of the large sub-rectangular type, sometimes in the red fabric mentioned above. Some of these late dishes could conceivably have come from Ipswich, but none is stamped (see above). Further evidence for the late use of Staffordshire-type slipware dishes in the area is provided by a dish donated to Colchester Museum in 1931 which had been in use in Colchester up to 1920 (*CMR* 1932, 43; *CM* 1316.31). Many examples, including the latter, are sooted from being placed by the fire probably to keep food warm.

**Staffordshire-type iron-streaked earthenware**  
(Fabric 50A)

---

Weight: 0.010 kg

Number of sherds: 2

This has a cream- or buff-coloured earthenware fabric with occasional streaks of white and reddish marl similar to some Staffordshire slipware fabrics (Fabric 50). The surfaces are covered with a clear lead glaze which is streaked or mottled brown by the addition of iron or possibly manganese.

Variations of this fabric were produced at numerous centres in Staffordshire and elsewhere in the Midlands between c 1680 and 1750 (Kelly & Greaves 1974, 3; Jones 1988, 27-8).

Fragments from two cylindrical tankards were recovered (not illustrated: CPS F172 & MID AF1). A more complete tankard profile bearing a William III excise mark was recovered from the Angel Yard excavation (not covered by this volume). Tankards were among the commonest forms produced in this fabric. The forms, the mottled glaze and the excise marks appear to be in direct imitation of stone-ware forms.

---

## Chapter 6. English wares: modern (c 1750 onwards)

---

### Modern English wares

This is a loose term covering a wide range of relatively recent products mostly post-dating c 1750, although a very small percentage may slightly predate c 1700. The great majority, however, dates to the 19th and 20th centuries, being the products of the increasingly industrialised and large-scale potteries of the North and of the English Midlands, particularly Staffordshire. It was largely due to the rise of these northern industries that the increasingly few and small-scale native Essex potteries died out.

'Modern' English wares comprise around 7.5% of all post-Roman pottery recovered from the excavations. From the outset it was realised that detailed recording and publication of most of these 'modern' wares would greatly overstretch the resources set aside for the study of pottery from the excavations. As the nature of rescue excavations not infrequently involves the machining-off of the first few feet of topsoil, there are relatively few good contexts of the late 18th and 19th centuries\*. Bereft of useful associations, a detailed study of the modern wares recovered would be of dubious value. Though they are not without interest, many of these wares have already been the subjects of numerous and detailed antiquarian studies whereas the local wares of medieval and post-medieval Colchester have not.

Given these priorities, a summary approach to the recording of modern fabrics was adopted. At its most basic, only the type of ware and its weight was recorded, and this therefore is the only means of quantification by which the differing amounts of modern wares may be compared both to each other and to the earlier wares. Some modern fabrics however have received more detailed quantification and recording, and this will be indicated where relevant. Comments on maker's marks and other points of interest were recorded for all modern wares and may be consulted in the computer archive. Only Fabrics 51A and 40E have been illustrated as these have rarely been treated from an archaeological viewpoint.

### Documentary sources

A good picture of the arrival and variety of these wares reaching the town can be gleaned from documentary sources. We have been fortunate in that local historians

researching this period have come across several interesting references to pottery and pottery dealers in 18th-century Colchester. We are particularly indebted to the late John Bensusan-Butt for making available his numerous extracts from the *Ipswich Journal* and correspondence relating to local pottery dealers. An account of these is given below.

The earliest pottery dealer we know of is a certain John Rogers, Junior (1716-1782), a local Quaker. Rogers sometimes described his profession as 'Chinaman'. In 1752 he had a goods warehouse near the Red Lion Inn in Colchester High Street 'for Staffordshire, Liverpool Earthenware, Bow China etc., Tunbridge and Turner ware, wax toys and cheese etc etc' (*Ipswich Journal*, 15 December 1752). On June 1st 1754, Rogers placed a lengthy advertisement in the *Ipswich Journal* which is worth quoting in full:

'John Rogers, Junior. Near the Red Lion Inn in High-Street, Colchester: Has lately open'd a large stock of Liverpool ware, which much resembles foreign China; consisting of Dishes, Plates, Punch-Bowls, Mugs, Fruit-Baskets, Flower-Horns, and Cisterns, &c. Staffordshire Stone and Earthen-Ware; Holland Stone Pots, Gotches, Bottles, and Tiles; where Country Shop-keepers and others may be served with the aforesaid Wares as cheap as in London. He likewise sells foreign and Bow China. London Earthen and Stone Wares, and Glasses of all Sorts, Coffee, Chocolate, and Confectionary Wares; fine Snuff and Snuff-boxes of several Sorts; Mohogany Tea-Boards, Bottle-Stands and Waiters; Tea-Chests of several Sorts; Coffee or Chocolate Mills, Equipages or Dumb-Waiters, Pepper-boxes, Punch-Ladles, Tobacco-Dishes, Powder and Patch-Boxes, Dressing-Boxes and Leather Trunks, China Plate, Bread and Work-Baskets, painted Floor-Cloths, Brushes, Pails and Sieves; Looking-glasses; Glass Barrels, Lanthorns and Lamps; variety of Wax, Dutch, and other Toys; fine India Fans; Ribbons, Hankerchiefs, Stockings and Caps; Poland and Norwich Starch; Blues of all Sorts; Bostocks's, Stoughton's and Daffy's Elixirs; Batemans's Drops, Godfrey's Cordial, Spirits of Scurvy-Grass, and Anderson's Scotch Pills; also Butter and Cheese, wholesale and retail at reasonable rates. N.B. He has a great Quantity of foreign China, new come in, to be sold very cheap.'

Several points of interest emerge from these two advertisements. The mention of Staffordshire earthenware most probably refers to lead-glazed earthenwares of the Whieldon and Astbury types and perhaps also Creamware (though not yet Wedgwood's 'Queenware'). It might just refer to Staffordshire slipwares, although these would seem slightly down-market given this context. Liverpool ware and Liverpool earthenware 'which much resembles foreign china' can only be a reference to Liverpool delft; porcelain was not

\*The general policy was that all contexts earlier than c 1700 were subject to normal excavation. In practice, sequences of deposits up to the present day were often dug and recorded, invariably so on the sites of medieval and later buildings, although the practice of inserting suspended timber floors into houses from the 18th century onwards means that very late stratified sequences are not common. Pits and other substantial cut features post-dating c 1700 were always dug where they cut into pre-1700 deposits. The finds from all excavated contexts have been kept, although some 19th- and 20th-century material was discarded after the initial post-excavation processing.



produced here until 1756. Similarly London earthenwares must be a reference to London delft and Lambeth delft in particular. Stonewares from Staffordshire and London are specifically mentioned in the advertisement. 'Holland stone pots' must be a reference to German stonewares, in particular Westerwald stoneware re-exported from Holland to England. Holland itself had no tradition of stoneware manufacture. 'Gotches' is an old East Anglian word for large jugs. The 'tiles' mentioned must be Delft tiles, which are common enough in Colchester.

The references to 'foreign china' and 'China plate' are the earliest we have for the town and suggest it was commonly available by the mid 18th century. Bow China was patented in 1744 but was probably unsuccessful until its bone china patent in 1748. The reference to its presence in Colchester only four years later is therefore surprisingly early. 'Tunbridge ware' and 'Turner ware' are unlikely to refer to pottery. 'Turner ware' is probably the same as 'turnery wares', which in a Colchester advertisement of 1780 (see below) is clearly a reference to wood-turned vessels (treen). Tunbridge Wells had no pottery industry of note and 'Tunbridge ware' refers to the wooden inlay vessels of that town.

In the 1750s and 1760s we have the interesting development of Staffordshire potters settling in Colchester itself and acting as agents between the Staffordshire potteries and the growing markets of north Essex and Suffolk. At least two such individuals (Richard Hassells and John Keeling) claimed to be 'pot makers'. A more likely interpretation, however, is that they began their working lives as Staffordshire potters in the family firm but moved increasingly into the sphere of pottery marketing. This required them to find new outlets beyond Staffordshire, and perhaps to settle there, but remaining, however, in close contact with the family firm to the benefit of all concerned.

The families of Hassells and Keeling were well-connected with Staffordshire pottery circles of the 18th and early 19th centuries. Godden (1983) lists several Keelings working at Burslem, Tunstall and Hanley from c 1777 onwards. Attempts to produce Staffordshire hard-paste porcelain were first carried out at Anthony Keeling's factory in Tunstall in 1781, but were removed to Shelton a year later (Honey 1964, 207). The Hassells are a little more obscure, but research carried out in 1971 by D Robinson (Assistant County Archivist, Staffordshire) shows that a John Hassells of Shelton had a seal device on a teapot in 1761, and that John, William and Richard Hassells were involved in running a flint-mill at Hanchurch. A Richard Hassells (see below) left a will in 1760.

On the 28th of April 1759, William Hassells 'pot maker' placed the following advertisement in the *Ipswich Journal*: (abbreviated) '...just returned from his pot-house in Staffordshire, and has brought a large assortment of all sorts of stone and earthenware of the newest patterns viz White-stone, blue and white ditto; Agate, Tortoise Shell, Cream Colour and Black, both gilt, painted and enamelled... is at Bury... and his warehouse in Wyer St, Colchester (Sat-Mon only)'. About 1762 or 1763 a partnership was formed known as 'Hassells and Keeling Pot Makers', or 'Richard Hassells & Co.' Richard and William were probably brothers. John Keeling was the other partner. He was born in 1732 and was married at Burslem in 1761. On the 18th of June 1763, the above partnership was advertised in the *Ipswich Journal* along with their merchandise: 'Staffordshire Stone and Earthenware, Delft, Glass and Yellow Wares both hollow

and flat... warehouse in Wyer St. Colchester, every day and at Bury, Risby Gate, Weds to Thurs only. Letters directed to the Griffin in Bury or the Taylors Arms in Colchester'. The partnership was short-lived. It was dissolved on 5th May 1765 (*Ipswich Journal*) when we learn that they also had a warehouse near the Red Lion Inn on Colchester High Street. They may have shared or acquired the latter from John Rogers Jnr (see above).

The Hassells disappeared from the Colchester scene for there is no record of them settling down here. John Keeling, however, remained in Colchester. He still described himself as a potter in 1779 (petty sessions). Keeling carried on his business until his death in 1783 when it was taken over by his wife and then their son. John Keeling Jnr announced his retirement and sale of stock 9th July 1808 (*Ipswich Journal*).

One other advertisement of this period is also of some interest. In 1780 Joseph Coney announced the sale of his stock, describing himself as a 'cooper and dealer in china, earthenware and turnery wares, in the High Street, Colchester'. His stock consisted of '12 dozens of china cups and saucers, tea pots, basons etc. etc. a large quantity of earthenware, 60 malt and flour shovels, turnery scoops, jets, hand bowls, sieves, measures, pints etc.'

In his will of 1782, John Keeling left goods to his executor Edward Snell (died 1786). Snell was a wealthy Colchester merchant dealing in coals, corn, grain and various other commodities, and he owned quays at Wivenhoe and the Hythe (Colchester's port). It seems likely that Snell was involved in shipping Keeling's pottery down the coast to Colchester. The British Trades Directory of 1791 provides a more precise reference to the manner in which pottery was transported: 'There are two hoys to and from Colchester to Gainsborough and Hull for Staffordshire Ware, cheese etc. etc.'

## Catalogue of modern wares

In the following catalogue, detailed source references are rarely given. The main works consulted were: Jennings 1981 (a very similar but wider range to that of Colchester); Godden 1985; Honey 1964; and Askey 1981. In the table below, '(P)' indicates a partial quantification (roughly 60-90% of the true figure); blank spaces indicate no quantification (or absence of this data); otherwise assume full quantification.

### Red stoneware (Fabric 48R)

Unglazed red stoneware was first produced in England at the end of the 17th century and arose from attempts to copy imported Chinese red stoneware. Teapots were a popular form and were made at Staffordshire and Yorkshire. The excavations produced at least five vessels but none of these has typical 18th-century style engine-turned or sprigged

Table

	<b>Fabric</b>	<b>Weight (g)</b>	<b>Sherds</b>	<b>EVEs</b>
48R	Red stoneware	0.085	4	
45G	Nottinghamshire/Derby stoneware	4.770	126 (P)	1.59 (P)
47	Staffordshire white stoneware	1.845	117	3.59
48J	Jackfield ware	0.085	9	0.13
48W	'Whieldon'-type wares	0.055	4	
48C	Creamware	0.410	46 (P)	
49	Basalt ware	0.205	22	
48E	Yellow ware	11.005	420 (P)	
48D	Staffordshire white wares	57.520	2,361 (P)	1.48 (P)
48B	English porcelain	3.325	152 (P)	
45M	Modern English stoneware	26.955	333 (P)	16.49 (P)
51A	Slipped kitchenware	19.060	308 (P)	0.07 (P)
40E	Sussex inlaid slipware	0.005	1	
48L	Lustre ware	0.345	27 (P)	0.14 (P)
51B	Flowerpot	11.700	154 (P)	
48V	Sanitary wares	3.620	63 (P)	
48X	Miscellaneous earthenwares	5.265	112 (P)	1.34 (P)

decoration, although 18th-century vessels are probably represented by a foot-ring base and a squat bell-shaped vessel that may be a teapot lid or a hollow pedestal base, perhaps from a candlestick. The remainder come from 19th- or early 20th-century 'art pottery' forms including small hemispherical bowls or lids with a corduroy exterior.

#### Nottingham/Derbyshire stoneware (Fabric 45G)

Salt-glazed brown stoneware was produced in Nottingham from the late 17th to the 19th century. A contemporary industry in Derbyshire produced virtually indistinguishable products. Vessels are well made in a dark grey fabric with a distinctive lustrous brown salt glaze. Lathe turning was usual and many late products have simple rouletted bands of decoration. Most of the vessels from Colchester are probably 19th century, with large mixing bowls being especially common. These have either heavy bead or plain rims and flat or foot-ring bases. Rouletting is common. There are a few large jugs of similar character, a few storage jars and some lids. There are also several cylindrical tankards, and most of these have pad bases and are late. However, sherds from at least two finely-reeded tankards came from a good context with fifteen clay tobacco-pipes of c 1700-40 (BKC VF185). One of these tankards had a fragmentary excise stamp. These are the earliest examples of Nottingham/Derbyshire stoneware from the town.

#### Staffordshire-type white stoneware (Fabric 47)

This has a fine white fabric with a neutral salt glaze. Vessels were made to a high quality and were either wheel-thrown (hollow-wares) and subsequently turned on a lathe or were made in moulds (mostly flatwares). White stoneware of this type was made in Staffordshire from the first quarter of the 18th century until the last quarter. It is less well-known, however, that identical white salt-glazed wares (mostly hollow-wares) were made at Jackfield in Shropshire and were shipped down the Severn to Bristol and so to the American colonies. The range of forms present in Colchester has not been illustrated, but is very similar to that at Norwich (Jennings 1981, 222-7). Moulded plates are the commonest form present. Most of these have scalloped rims; mostly with the 'barley seed' pattern, less commonly with the 'dot, diaper and basket' pattern, and even less commonly with the 'bead and reel' and 'feather-edge' patterns (*ibid*, pl 1 c, d, b & g respectively). Foot-ring bowls and saucers occur with the same frequency as cylindrical tankards. Only one bowl or saucer has 'scratch blue' and roulette decoration below the rim. A few of the tankards have iron-dipped rims. There are two small moulded teapots and one or two examples each of jugs and jars.

#### Jackfield ware (Fabric 48J)

Jackfield ware has a fine dark red fabric with a highly glossy black glaze. This ware takes its name from Jackfield in Shropshire where it was produced from the 1740s until the late 18th century. It was also produced in Staffordshire in

greater quantities. This was a high-quality tableware with elegant tea and coffee pots and jugs being the main products. Shapes were often inspired by current fashions in silverware. Some pieces were painted and gilded. No more than six or seven vessels came from the excavations. One of these comes from the base of a tea or coffee pot with elegant tripod feet, and there is also a jug with a plain cavetto rim.

### Whieldon-type wares (Fabric 48W)

This term is here used rather loosely to refer to a group of wares produced at least from the 1740s by Thomas Whieldon, John Astbury and his son Thomas, and later by Josiah Wedgwood. The classic Whieldon product, usually teapots and dishes, had a fine cream fabric with mottled and polychrome lead glazes giving a 'tortoiseshell' or 'agate' effect. Surprisingly none of this was found on the excavations even though we know it was being sold in Colchester in the mid 18th century (see above). A quite different ware is often attributed to Astbury: this is a glazed red stoneware which may have sprigged decoration in white clay or may have engine-turned designs. Three vessels in this ware were found. Two probably come from the sides of engine-turned teapots while a third vessel has a plain pedestal base and could come from a jug. There is one example of a thin-walled cup or *capuchine* in 'solid agate' ware. This was produced by mixing different coloured clays together to produce a marbled or agate-like effect, a technique in which Wedgwood excelled.

### Creamware (Fabric 48C)

Figures given for this fabric are minimal and mostly represent classic 18th-century pieces instantly recognisable as Creamware and not its late 18th-century development into Pearlware. The latter being sometimes difficult to distinguish from body sherds has been amalgamated under Fabric 48D (see below). Creamware, later known as Queensware, is a fine cream-coloured earthenware with a transparent lead glaze. Vessels were made to a high standard with moulded and applied details and sometimes painting. It was introduced c 1740 and within two decades had supplanted tin-glazed wares and Staffordshire-type white stoneware as the normal tableware for everyday use. Apart from Staffordshire, the ware was also produced in Yorkshire, Derbyshire, Liverpool and Swansea (Jennings 1981, 227-9). This category has not been studied in great detail at Colchester where under 20 vessels have been identified. These include fragments of some high-quality moulded teapots (as Honey 1964, pl 8c) as well as bowls and scallop-rimmed plates.

### Basalt ware (Fabric 49)

Basalt ware or 'Egyptian Black' was developed by Wedgwood in the 1760s. This has a hard-fine grained black stoneware fabric which was left unglazed but was often polished, gilded or engine-turned. Elegant neo-classical vases, urns, and in particular teapots and teawares were the most popular forms. By the late 18th century, Basalt ware was being imitated both in Staffordshire and in many other potting centres. Its popularity continued well into the 19th century and Wedgwood still produce it today. Fragments from at least ten vessels came from the excavations, including teapots and teapot lids mostly with moulded decoration (acanthus leaf, fleur-de-lis and pennants) but including engine-turned specimens. Curiously only one small chip of Wedgwood's famous blue Jasper ware has been found on the excavations. One must assume it was, and still is, well looked after by the householders of Colchester.

### Yellow ware (Fabric 48E)

This has a buttery yellow fabric with a clear glaze, not to be confused with the pale cream fabric of Creamware. Unlike Creamware, yellow ware was primarily a utilitarian kitchenware with much plainer thicker-walled forms. At its best it was a down-market tableware with limited decoration such as the fern-like 'Mocha' design, along with wide and narrow horizontal bands in white, dark brown and blue slip. Rarer examples have an encrusted 'pebbledash' exterior. Some of the earlier jugs had handles with foliate terminals, and simple moulded friezes may occur below the rim on some vessels. Yellow ware developed in the late 18th century and was produced at several factories located in the major potting centres such as Staffordshire and Leeds. (The writer worked on the excavation of a yellow ware kiln at Jackfield in Shropshire which operated between the years c 1845 and c 1875.) The most common forms from Colchester are large mixing basins, smaller sugarbowls, some 'mocha' jugs and a sub-rectangular baking tray. Pots were very rarely marked, although one basin bears a 'W' (Warranted) mark on the underside.

### Staffordshire-type white earthenwares (Fabric 48D)

This is the largest category of modern wares. As defined here, this refers to refined white-bodied earthenwares with a neutral glaze and whose forms are clearly recognisable as the products of highly standardised or mechanised industries. It is thus something of a catch-all category, although in effect it consists almost entirely of 19th- and 20th-century blue transfer-printed tablewares, synonymous with 'Ironstone' and 'Willow Pattern'. Pottery of this nature arose in the Staffordshire potteries around the middle of the 18th century, particularly as a result of Josiah Wedgwood's

desire to produce an ever-whiter fabric with a colourless glaze. The addition of china-clay and china-stone a little before 1775 took Wedgwood towards this goal, and by 1780 he had modified his cream-bodied Creamware to a white-bodied Pearlware (Honey 1964, 88-9). Painted at first, in the manner of Chinese porcelain, these white wares were later transfer-printed (a technique already in use in the 1750s). The late 18th and the 19th century saw an explosion in the production of transfer-printed white wares in Staffordshire and numerous other centres around Britain. These cheap, attractive and serviceable wares swamped both urban and rural markets to become the most widely used tableware of the age.

These wares have not received close attention in Colchester. Late 18th-century painted Pearlware occurs but, as stated above, the vast bulk belongs to the 19th and 20th centuries. All maker's marks and pieces of particular interest have been noted in the computer archive. Maker's marks of the 1860s are particularly common.

### English porcelain (Fabric 48B)

---

This has not been studied in detail and the great majority of this consists of 19th-century forms such as plates, cups and saucers, but also a few teapots, candlesticks, chamberpots, egg-cups and childrens' toys.

### Modern English stoneware (Fabric 45M)

---

English stoneware of the 17th and 18th centuries has been considered in an earlier section. This section comprises 19th- and early 20th-century stoneware forms, mostly salt-glazed though some have a lead-based glaze. By far the commonest form (66%) was the cylindrical bottle with a carinated shoulder. These served as blacking bottles and soft drinks bottles. Most have a rim diameter of around 40 mm and could have served either purpose equally well (Askey 1981, pl 97 below). A smaller number with rim diameters of around 60 mm were exclusively for blacking or furniture polish (*ibid*, pl 132, top centre). Similarly, a small number of bottles with sloping shoulders, often white or with an iron-dipped upper half, were exclusively used for drinks such as ginger beer or stout (*ibid*, pl 110). Maker's stamps on these bottles show that the majority came from the Lambeth potteries in London and the Denby pottery in Derbyshire. Some stamps and transfer-printed designs give the name of the local merchant to whom the bottles were supplied. Stamps noted include:

'JOHN CLIFF & CO LAMBETH'. Operative 1860-69. Impressed.

'JOHN CLIFF & Co Ld LAMBETH'. Impressed,  
plus 'STOPES & SON COL(CHESTER) GINGER BEER'.  
Printed.

'DOULTON LAMBETH'. Impressed (three examples), c 1854+.

'STEPHENS ALDERSGATE LONDON'. Impressed.

'Ford Gallihan & Co. Leigh Essex'. Printed.

'STEVENS COLCHESTER'. Impressed (with globe in rectangle emblem).

'BELPER - BOURNE'. Impressed (fragment).

'BLACKING BOTTLE'. Impressed (two examples). Mark datable 1817-34.

'DENBY & CODNOR'. Impressed.

'...INN'S true reviver prepared by ... Pryce...'. Impressed.

'J. CLARKE EASTERN WORKS IPSWICH'. Impressed.

Jars are the next most common form in modern stoneware (18%). The great majority of these are cylindrical, often with a recessed base and a plain rim defined by a deep external groove. These were intended to contain jam, marmalade and meat or fish pastes (*ibid*, pl 144 below). Many are pale grey with vertical corduroy sides. These are less commonly stamped but sometimes have impressed numbers on the underside. One is impressed 'W H HARTLEY & SON LIVERPOOL' accompanied by a lighthouse emblem.

Large flagons, mostly straight-sided comprise 12% of all forms. Stamps on these include:

'(OSBOU)RN (MER)CHANT'.

'G M Clare Wine & spirit merchant. Bottom of North Hill Colchester'.

There are three lids (2%), including one from a large filter with sprigged decoration; one small syphon stamped 'BLACKWOOD & Co's PATENT SYPHON'; one tankard; one small conical pharmaceutical measure; and two dish-like forms.

### Late slipped kitchenware (Fabric 51A)

---

[Fig 171]

At least two very similar pottery types are included under this category: press-moulded sub-rectangular dishes with thick trailed cream slip decoration, and wheel-thrown vessels (mostly jars) with a thick internal covering of cream slip. Both have a dense dark reddish-brown slightly sandy fabric showing a dark brown toffee-like colour when covered by clear glaze. Along with Staffordshire-type white earthenwares and Yellow ware (Fabrics 48D & 48E), this fabric was to a large extent responsible for displacing locally produced coarsewares. It is less refined than most 'modern' wares and so has some claim to be regarded as the major locally used coarseware of this period. For this reason it deserves more than a passing mention.

Most of this pottery dates to the 19th and early 20th century. There is little doubt that the sub-rectangular dishes (Fig 171.3) come from the north-east of England where a tradition of making slip-trailed sub-rectangular baking dishes continued into the earlier part of this century. Examples are often ascribed to Sunderland or Newcastle. A dish of this type is illustrated by Brears (1971, 63-4). The dishes are covered internally with a regular clear glaze which extends about halfway down the outer wall. Designs in thick cream slip are loosely executed and simple, often consisting of sinuous lines, dots and groups of concentric crescents on

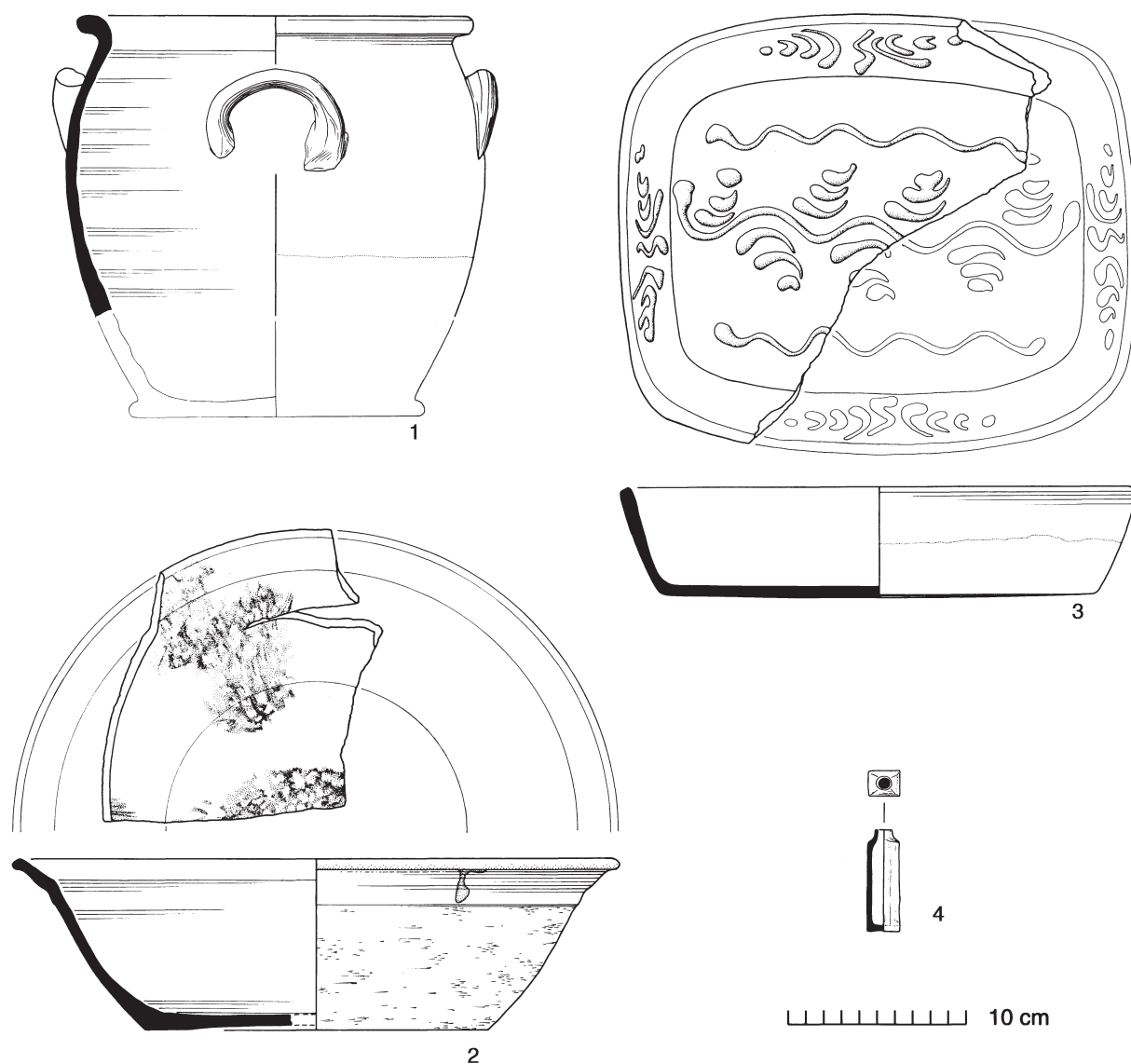

Fig 171 Late slipped kitchenwares: storage jar (no 1); bowl with iron-mottled decoration (no 2); Tyneside slipware dish (no 3); Rawmarsh-type bottle or phial (no 4). 1:4.

the floor of vessels and groups of crescents in the middle or running along the length of the inside wall. In all cases the decoration appears to represent highly stylised vegetation, fronds, tendrils, stems etc. These sometimes occur in symmetrical and simple geometric patterns. Some examples have a solid central wall dividing the dish into two halves.

Wheel-thrown vessels are much commoner than the sub-rectangular dishes. All of these have a thick internal covering of cream slip under a clear glaze. The slip usually ends in a neat line at the lip of the rim though occasionally there is some overspill. On jars the glaze also covers the outside ending a short distance above the base. On the smaller shallow dishes and bowls, the glaze usually ends a little below the rim, but on larger forms it covers much of the outside. Apart from the internal slip, decoration (if it can be called that) is confined to occasional external grooves, but some dishes and bowls (Fig 171.2) may have cloudy

mottled brown areas where flecks of iron or manganese oxide have been added to the slip. Storage jars (Fig 171.1) are one of the commonest forms. These are globular with a high neckless shoulder tapering to a flat or slightly padded base. Rims are simple, thickened and everted or flanged and everted. Just below the rim is a pair of arched lug handles. Jars of this description may be found in local antique shops and are still used as garden pots in many Colchester gardens today. Other forms include large pans or mixing basins and a number of smaller bowls and dishes with simple flanged rims.

Pottery of this type was made in the north Midlands including South Yorkshire, which is the most likely source for the vessels found in Colchester and probably most of East Anglia. A drawing of the Silkstone Pottery in 1806 and a photograph of the Littlethorpe Pottery (near Ripon) c 1913 show a range of pottery identical to much of that from the excavations (Brears 1971, 104).

The earliest evidence for the Silkstone Pottery is a bottle made for Richard Bailey inscribed 'R.B. 1779'. The pottery was last mentioned in 1815 (*ibid*, 230). In the Ashmolean Museum, Oxford there is a dish described as 'perhaps Yorkshire' (WA 1982.50). This indeed looks very like Fabric 51A though this dish has simple sgraffito decoration and the inscription 'RBA 1767'. It also has flowing cloudy brown streaks and some patches of green colouring. If not an actual Silkstone product this dish is at least a product of the same general industry.

Although unslipped, Figure 171.4 has the same dark red fabric as the Yorkshire wares. The form is that of a small square-section ink-bottle or phial with a shiny black glaze restricted to the rim and shoulder. This is a distinctive form of ink-bottle produced at Rawmarsh near Rotherham, Yorkshire in the late 18th and early 19th centuries (Milefanti & Brears 1971, fig 68.6-8).

In Colchester itself there is no definite evidence for the presence of this fabric before c 1800. In the scores of contexts in which it occurs, it is always found with Staffordshire-type white earthenwares (Fabric 48D). In the rare situations where it does not occur with this fabric, it has no useful dating associations. As we have seen, Fabric 48D does not predate c 1780 (*see above*), so it is just possible that Fabric 51A was reaching Colchester at the very end of the 18th century. Several of these contexts also contain Staffordshire-type white stoneware and other distinctive types of c 1740-80 which, if not slightly residual, were still being discarded at the end of the 18th century. In one pit context (LWC VF3), a brown-mottled Fabric 51A dish is associated with a large quantity of pottery of c 1800-25 which includes most of a transfer-printed Pearlware jug with oriental scenes. Figure 171.2 occurs in a large group of pottery from a brick latrine (LWC VF1), much of it recognisable 18th-century types with the latest material being clay pipes of c 1780-1820 and a Staffordshire pottery mark datable to 1827-40. The ware is common throughout the rest of the 19th century and the early part of the 20th century.

### Sussex inlaid slipware (Fabric 40E)

[Fig 172.1]

A single partially burnt sherd of this was found in a 19th-century context. It comes from the wall of a cylindrical

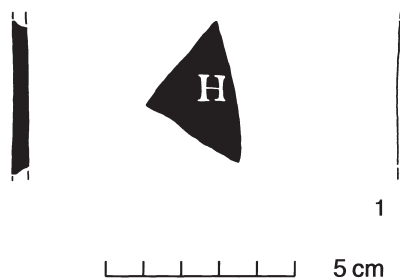

Fig 172 Sussex inlaid slipware: ?tobacco jar (no 1). 1:2.

vessel, perhaps a tobacco jar, with a diameter of around 100 mm (Fig 172.1). The fabric is fine, pasty and pale orange-pink with few visible inclusions save for a few fine streaks of cream-coloured marl and some redder iron streaking. Both sides are covered with a bright amber-coloured clear glaze. On the outer surface a single letter 'H' survives from a stamped inscription in metal-type characters subsequently infilled with a cream slip.

Inlaid slipwares were typical of a small group of Sussex country potteries, most notably Brede and Chailey, where spirit flasks and other forms with short commemorative inscriptions were made during the late 18th and early 19th centuries (Brears 1971, 69-70, pl 86). Similar wares, with a darker iron-streaked glaze, were also produced at the High Halden pottery near Ashford in Kent.

### Lustre ware (Fabric 48L)

Lustre was a technique of decoration rather than a pottery type and it may be found both on red and white earthenwares and on porcelain. This shiny metallic effect was achieved by adding a film of reduced metal oxides to the surface of the pot. Gold produced a pink lustre on a white fabric and a coppery lustre on red fabrics; platinum produced a silver lustre. The lustre technique was developed at the very end of the 18th century. The earliest dated pieces commemorate the opening of the Sunderland Bridge in 1796, though most pieces date to the 19th century. Lustre ware was produced in Staffordshire, Sunderland, Newcastle and Swansea. Most of the eleven or so vessels from the excavations have the marbled pink lustre typical of Sunderland. A small cream jug and a bowl from the same context depict the opening of the Sunderland Bridge with the date 1796 (BKC JF4).

### Flowerpot (Fabric 51B)

Eighteenth-century flowerpots have been considered along with Fabric 40 (*see pp 215-7*). This category is almost exclusively comprised of standard 19th-/20th-century flowerpots and trays in porous unglazed red earthenware although one or two porous garden jars are included. Many flowerpots may be of local manufacture. Those with impressed stamps, however, are Sankeys products from Nottinghamshire.

### Sanitary wares (Fabric 48V)

These come from sanitary applications, such as water closets, in vitreous white earthenware. The fabric is basically similar to Fabric 48D, and some water closets (as in the Gladstone Museum, Stoke-on-Trent) may have transfer-printed decoration although those from the excavations are plain.

### Miscellaneous earthenwares (Fabric 48X)

---

A diverse catch-all category. For the most part, however, it consists of Staffordshire-type white earthenwares with a coloured or polychrome glaze. This includes a few Wedgwood-type products with green or *maiolica* glazes. At the later end of the range it includes red or white fabrics, often teapots, with brown, black or other coloured glazes. Occasional electrical fittings are also included, such as a porous pot from a Leclanche cell (from Victorian battery-operated doorbells).

## Chapter 7. French wares

### An outline of contact with France

[Fig 173]

There is no historical record of any contact between Colchester and France after the Roman period until the Norman Conquest in the 11th century. The archaeological evidence is very slight, consisting of a northern French or Rhenish brooch of the 6th century (*CAR 1*, fig 18.3), a 'Merovingian' pot from Old Heath (*ibid*, fig 27), and the few sherds of Merovingian or Frankish wares described below. Of 276 burgesses listed in the Colchester Domesday, six individuals (2.2%) had names derived from Old French or Norman (*ibid*, 77). Direct contact between Colchester and the wine-producing area of Gascony is first mentioned in the late 13th century and in the 14th and 15th centuries. Gascon wine shipped directly to Colchester's port (and also via Harwich, Ipswich, London and Sandwich) was the town's most commercially important link with the Continent (Britnell 1986, 11, 13, 19, 63 *passim*). Salt was also imported from the Bay of Bourgneuf. The chief out-going product was cloth, and Colchester cloth was well known on the Continent (*ibid*). French wine and salt continued to be imported in the early 17th century though by now it was via ships from the Low Countries rather than by direct contact (Davis 1981, 16-17).

It is often claimed that the export of Saintonge ware to Britain was linked to the Gascon wine trade (Hurst *et al* 1986, 76). Certainly Saintonge ware is the most numerically significant French fabric from the excavations although no more than 25 vessels can be represented, of which perhaps 20 are medieval and connected with the serving and storage of wine. This seems rather a low figure given the importance of the Gascon wine trade to Colchester vintners, but it could nevertheless be a slight reflection of the importance of this trade when compared to the much smaller numbers of vessels in other French fabrics. Based on the material from recent excavations and that in Colchester Museum (in brackets), the minimum numbers (MNV) of French vessels imported into Colchester may be summarised as the following table.

Table

Period	MNV	Fabrics
6th-9th century	2(+1)	97F
10th-12th century	2	95P, 95M
13th-15th century	26(+1)	27, 28
16th-17th century	28(+8)	27, 30, 43, 45J
<b>Excavated total</b>	<b>58(+10)</b>	
<b>Full total</b>	<b>68</b>	

### Wheel-thrown Frankish sandy wares (Fabric 97F)

[Fig 174.1-2]

Weight: 0.020 kg

Number of sherds: 2

EVEs: 0.05

Two quite different vessel forms and traditions are represented by this material. The first of the two sherds (Fig 174.1), both identified by Catherine Coutts in 1986, is from Lion Walk Site H and almost certainly comes from the shoulder of a globular wheel-thrown jar with a hard, dark grey sandy fabric containing abundant medium quartz, sparse chalk, red iron oxide and sparse inclusions of coarse flint. The outside is decorated with a horizontal groove, below which the surface of the vessel is smoother, and a band of roller-stamped chevron-like motifs. The chevrons are doubled (ie a smaller chevron nests inside the larger), and there are hints that the original design would have been a sequence of alternating upright and inverted double chevrons.

The fabric and decoration of this jar identify it as belonging to a class of imported wheel-thrown vessels produced in northern France and Belgium and whose English distribution is largely confined to east Kent where they occur in Anglo-Saxon cemeteries (Evison 1979). The LWC H sherd belongs to Evison's group 4 globular 'bowls' (*ibid*, 16), though most look like jars. These are closely related to Group 3 biconical 'bowls' of which an example of 'Beerlegem type', possibly from Belgium, has been found at Old Heath, Colchester and has been reported by Vera Evison elsewhere (*ibid*, fig 16d and *CAR 1*, fig 27).

With the exception perhaps of Hamwic (Southampton, Hodges 1981) and a few other instances, where they occur in domestic contexts, wheel-thrown Frankish pottery in England occurs almost exclusively as accessory vessels in inhumation graves and a very small number of cremations dating to the second half of the 6th century and the 7th century (Evison 1979, 45).

Chevron rouletting is fairly common on globular 'bowls'. Normally there are two or three bands of rouletting on the upper part of the body. A very close parallel for the Colchester design occurs on a globular pot from a 7th-century grave at Broomfield near Chelmsford, Essex (*ibid*, fig 16g), which included a sword, *cloisonné* jewellery and a squat glass jar. An equally similar pot comes from Faversham, Kent (*ibid*, fig 164), and two pottery bottles from Dover and Margate in Kent also have up to six horizontal bands of very similar decoration (*ibid*, fig 11a-b). Vera Evison notes that chevron rouletting is quite common in the cemetery of Harmignies and at Ciplu, both in south-east Belgium (*ibid*, 36).

The LWC H sherd came from a pit containing only a few sherds of local Saxon pottery (Fabric 97) and also a few



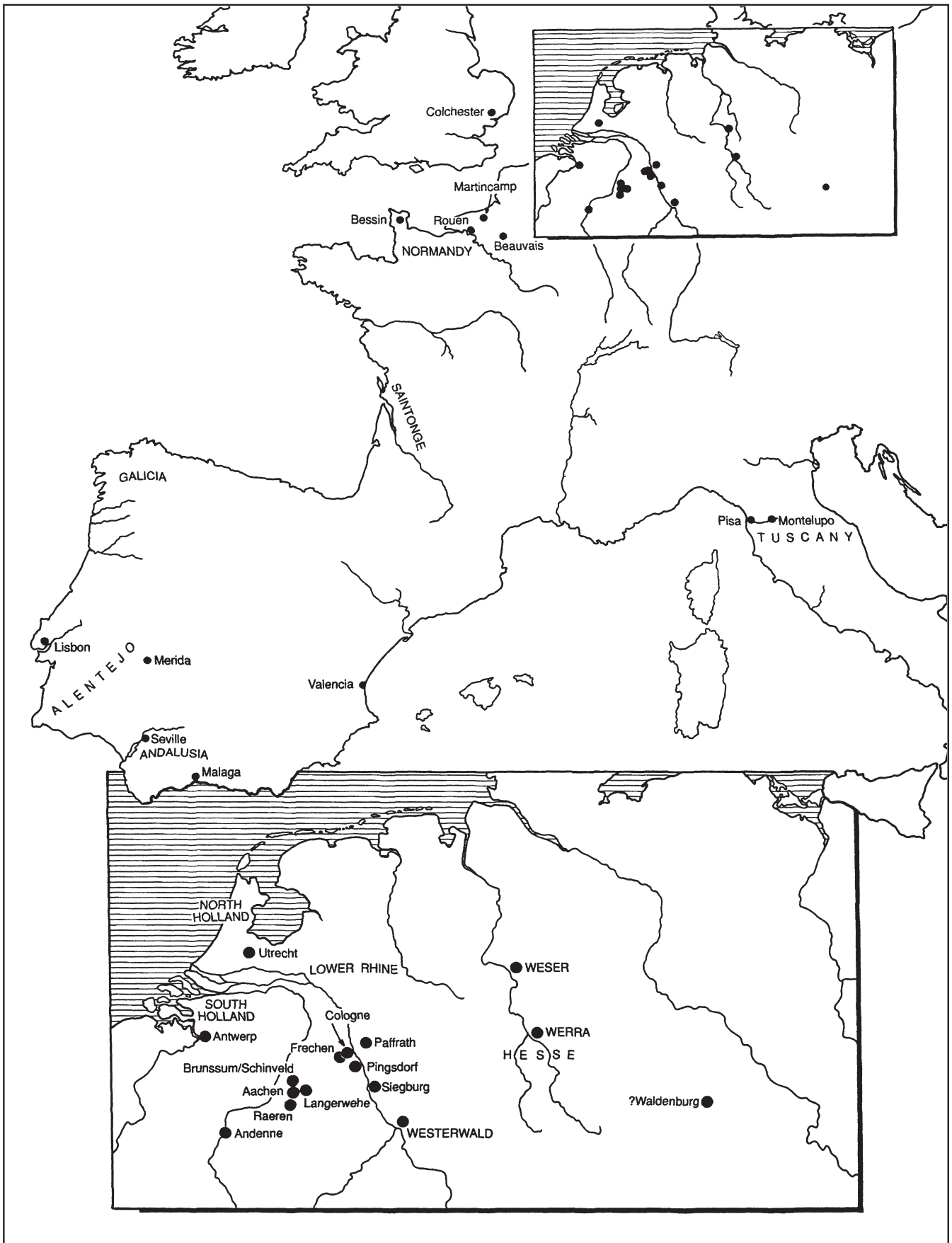

Fig 173 Map of western Europe showing the sources of medieval and post-medieval imported wares at Colchester.

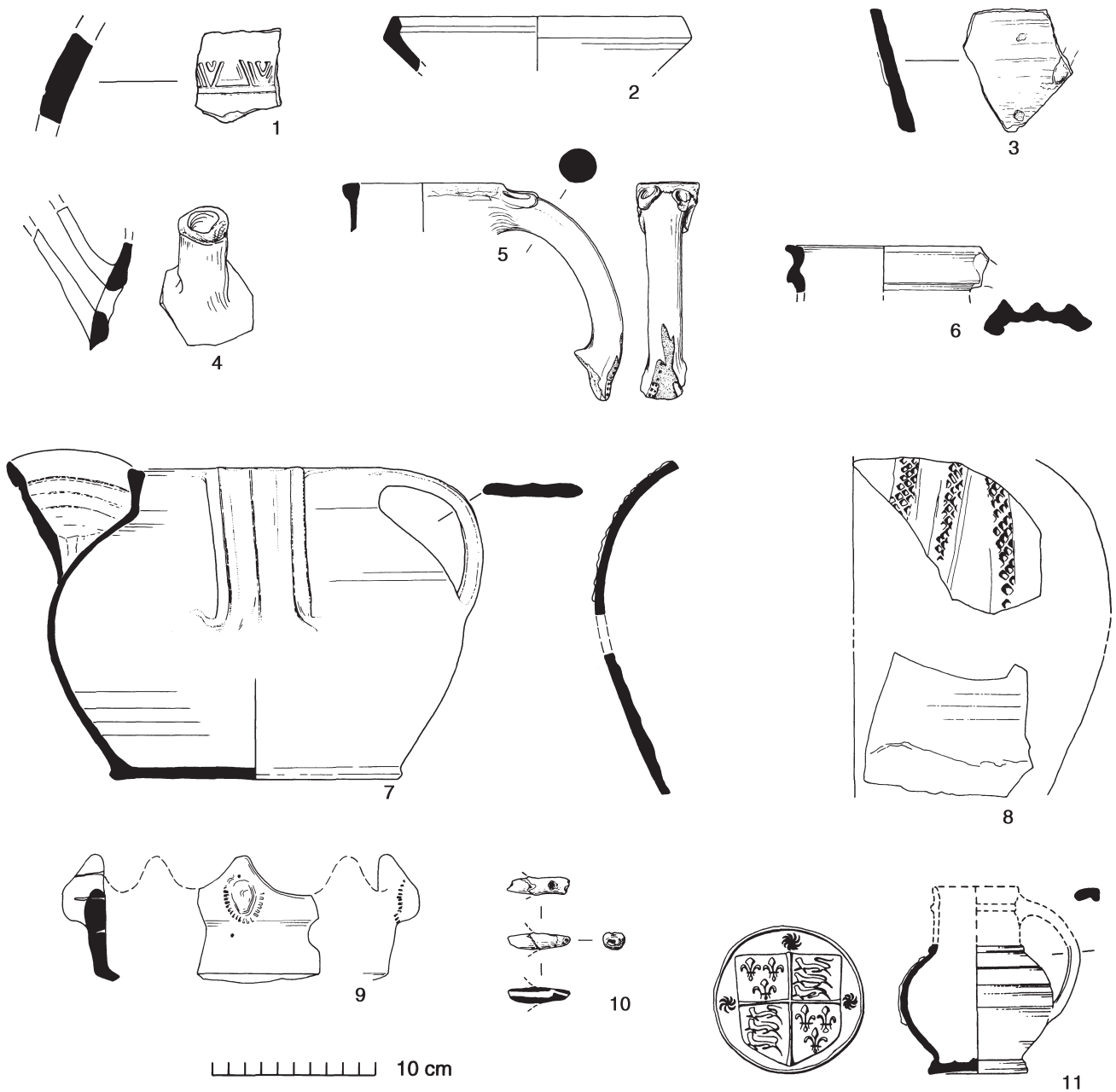

Fig 174 French wares: wheel-thrown Frankish sandy wares (nos 1-2); North French yellow glazed ware (no 3); French micaceous ware (no 4); Rouen-type ware (no 5); North French monochrome ware (no 6); Saintonge ware pégau (nos 7-8); chafing dish (no 9); bird whistle mouthpiece (no 10); Beauvais earthenware jug (no 11). 1:4 except no 1 at 1:2 and no 11 medallion at 1:2.

sherds of c 12th-century Fabric 13. This pit lay only a metre or so away from a 5th-century sunken hut (Stratified Group 1), but this is probably just coincidence. It is curious to note that neither this sherd nor the complete vessel from Old Heath come from grave contexts; however, the LWC H sherd could have been redeposited from elsewhere and the Old Heath pot was found in uncertain contexts. The fact that Old Heath was the presumed Saxon port of Colchester may be significant, suggesting perhaps that the pot was accidentally lost in the now-vanished creek. Both pots may

well have reached the town via Old Heath, carried perhaps on boats from Kent or directly from the Continent. One other sherd from Colchester might possibly be from a wheel-thrown Frankish bottle, but is perhaps more likely to be English (Fabric 8V, Fig 8.1).

The second Frankish vessel from the excavations (Fig 174.2) comes from Lion Walk Site A and is part of a straight-sided bowl with an unusual inverted rim (which alternatively could be described as a carinated bowl). It is a

dark grey colour in the rim area (perhaps burnt?) becoming paler grey lower down, almost approaching a buff tone in the lower margins. The whole exterior is covered with a glossy black slip or slurry which has a pimply texture due to the coarse underlying inclusions. The fabric is akin to Paffrath-type ware or *Eifelkeramik* in texture. It is very dense and laminated with a fine or pasty matrix containing a moderate-abundant scatter of coarse inclusions up to 2 mm across, but typically 0.5-1.0 mm. These probably derive from an igneous or metamorphic source as they include angular quartz, mostly white and iron-stained, tabular iron-stained calcite or aragonite crystals, sparse glassy black crystals (perhaps tourmaline or pyroxene), white mica, red iron oxide and grey-brown clay pellets and perhaps rock fragments. Such a petrology points to an igneous/metamorphic area such as Brittany/Lower Normandy, or perhaps the Massif Central or even the Eifel region of West Germany.

Carinated bowls were fairly widespread on the Continent. R A Hodges illustrates a broadly similar example of the 7th or 8th century from La Saulotte, around 60 miles south-east of Paris (Hodges 1981, fig 7, 11.1), and similar forms are known in *Eifelkeramik* until at least the 7th century (Redknap 1987b, fig 9.B), although the Lion Walk bowl does not necessarily come from either of these sources. An 8th- or 9th-century date has tentatively been suggested (Catherine Coutts, pers comm, 1986). The sherd was found in a layer of late Roman or early medieval topsoil over a Roman tessellated pavement. A Roman identification for the sherd has been investigated but discounted.

#### 'Pudding Lane'-type North French glazed ware (Fabric 95P)

[Fig 174.3]  
Weight: 0.050 kg  
Number of sherds: 1

A single sherd from the excavations (Fig 174.3) has been identified by Alan Vince as being an example of a 10th- to 11th-century north French glazed ware of a type known from excavations at Pudding Lane and Lime Street, London (Vince 1985, 39-40, fig 10). Vessels are characterised by a decoration of applied roller-stamped strips arranged in a curvilinear fashion. The Colchester example has a hard streaky cream/pink fabric with abundant ill-sorted coarse inclusions, predominantly quartz with moderate red iron oxide and rare very coarse white inclusions of differing character (possibly feldspar or limestone), some rare soft translucent greenish inclusions (?glaucanite), and abundant fine white mica. There is a trace of an oblique applied strip and the whole exterior is covered with a thin rich yellow lead glaze. The sherd, which is much abraded, comes from a pit or slot (LWC GF242) containing only early medieval sandy ware (Fabric 13); it is assigned to the period c 1125-50 on the basis that it cuts a complex of Norman robber trenches which produced a coin of c 1105 probably lost by c 1115 (CAR 4, 65).

#### Unprovenanced French micaceous ware (Fabric 95M)

[Fig 174.4]  
Weight: 0.075 kg  
Number of sherds: 1

Figure 174.4 has been identified by Alan Vince as an early medieval micaceous French ware from a source yet to be identified. It is known in London from excavations at Southwark (Alan Vince, pers comm, 1987). The fabric is fairly hard and buff-pink with abundant medium-coarse white mica and a moderate amount of coarse-very coarse sub-angular white quartz and red iron oxide. It is covered externally with a pitted pale green copper-flecked glaze. This comes either from a wheel-thrown jug or pitcher with a long and rather irregular applied tubular spout, or it may come from a pipkin-like vessel with a tubular handle. It was found in an early medieval robber trench (1.81 EF117) which also contained Thetford-type ware and early medieval sandy ware (Fabric 13) of 11th- or early 12th-century character.

#### Rouen-type ware (Fabric 28)

[Fig 174.5, Fig 222.28]  
Weight: 0.245 kg  
Number of sherds: 9  
EVEs: 0.15

Rouen in Normandy was an important pottery producing centre whose distinctive early/mid 13th- to 14th-century jugs are found on a number of British sites, particularly in the south of the country (Platt & Coleman-Smith 1975, fig 179.971-77). The fabric is generally fine and white to buff with occasional sand grains. This is a rare fabric in Colchester with only six or so vessels represented, apparently all jugs. Figure 174.5 is the largest piece recovered. This has the typical Rouen 'ears' on top of the handle which has a typical rod-section. Towards the base of the handle is a red painted zone overlain by two applied strips of body clay with roller-stamping. The whole exterior is covered with a thin yellowish clear glaze with one speck of green. This was found with a worn coin of 1335-41 which was probably deposited c 1400 (CAR 4, 65). The handle itself also shows considerable wear. Another handle sherd has a pellet or blob of red clay, and two green-glazed sherds have applied roller-stamped strips with a square cogged design (Fig 222.28; Stratified Group 10, c 1400-50+).

A single small sherd of late Rouen-type ware was found in a context of Period 3/4.1 (c 1200-1500, CPS L22; identified by Alan Vince). This has an applied pellet of body clay and speckles of red paint below the glaze. A larger specimen of late Rouen-type ware was found at 63 North Hill and is in Colchester Museum. This comes from the upper part of a jug with rod handle and 'ears'. On the body there is a fragmentary design of applied roller-stamped strips arranged in the form of lozenge-shaped brooches; the glaze is clear with flecks of red paint beneath.

## Saintonge ware (Fabric 27)

[Fig 174.7-10]

Weight: 2.605 kg

Number of sherds: 141

EVEs: 1.08

This category includes fine white earthenwares made principally in the Saintonge area of south-west France. However, Fabric 27 also includes a small number of miscellaneous fine white sherds (mostly green glazed) which are presumed to be of French origin even if not from the Saintonge itself. Fine lead-glazed white wares, often decorated, were produced in the Saintonge and widely traded along north Atlantic seaboard from the 13th until the 18th century (Hurst *et al* 1986, 76-99). A minimum of 25 vessels are represented by the excavated material from Colchester. These may be divided as follows: jugs (5 polychrome and 12 green monochrome examples); *pégaux* (3 or 4 examples); chafing dishes (3 examples plus at least 3 others in the Colchester Museum); whistles (1 example).

Jugs are represented mostly by small fragments, none of which merit illustration. Polychrome jugs are considered to have a date range restricted to the late 13th and early 14th centuries (Hurst 1974, 221). This accords well with the occurrence in Period 3.2 of a slightly splayed pedestal-like base from a baluster jug with traces of painting (MID CL113). This occurred with a baluster jug in Mill Green ware conventionally dated *c* 1270-1350. The designs were painted in black, green and yellow-brown and, although none is complete enough to be intelligible, they probably represent the shield, bird and foliage designs normally found on polychrome jugs (eg as at Southampton: Platt & Coleman-Smith 1975, figs 186 & 188.1047). One other polychrome sherd occurs in the earlier Period 3.1 but only in association with local 13th-century wares.

The green-glazed monochrome jugs are considered to have a wider date bracket, perhaps from the early 13th century until well into the 15th century or possibly even later (Hurst 1974, 221-2). Sherds of green glazed jugs, some with applied notched or roller-stamped strips, occur in Period 3.2. There is one fragment from a jug with an externally furrowed collared rim (Fig 174.6). This came from a robber trench and was associated with 13th-century Hedingham ware and a Paffrath-type ladle of similar date. However, the fabric of this rim is not that of true Saintonge nor of Rouen ware, but it could be an example of north French monochrome ware.

*Pégau*x are large jars usually with an applied beak and three strap handles. Their function was almost certainly the serving of wine. The two certain examples illustrated here (Fig 174.7-8) are of 14th-century type (see Platt & Coleman-Smith 1975, fig 188.1048-50 & fig 189.1053-4). Figure 174.7 was found virtually complete in a 14th- or early 15th-century pit (Period 4.1). Only the tops of the rim and handles and the internal floor of the vessel are covered with a mottled green glaze. A small beak fragment was found with Figure 174.8 making its identification as a *pégau* beyond question. Only the shoulder is green glazed and the vessel was presumably residual in its 17th-century context.

Figure 174.9 (unstratified) comes from a Saintonge chafing dish of Hurst type I with zones of green and yellow glaze (*c* 1500-1600; Hurst *et al* 1986, fig 35.104). In addition to a

handle from the excavations, there are at least two examples of this type in the Colchester Museum (CM 1992.31 Crouch Street; OS 3.1964 Head Street). The latter example is a complete hollow pedestal with four handles, but the entire upper half is missing and it appears that the broken edges were filed down smooth so that the vessel could continue in use. Also in the museum, there is one mask and part of the body wall from one of the rarer type V chafing dishes (CM OS 5.1964). This has a bearded mask within a roundel within a rectangular frame with pellets in each corner (as Hurst 1974, fig 8.36). Originally the projecting rectangle would have been crowned with a horizontal rosette but this has been broken off. The outside is probably covered with a white slip over which there is a pale green-tinted clear glaze. The beard and other details of the mask itself have highlights of darker green while the inside bowl has a plain yellow glaze.

Figure 174.10 is the mouthpiece of a Saintonge whistle. These date to the 16th and 17th centuries and are normally in the form of birds with a mouthpiece at the tail end and with an external polychrome glaze (Hurst 1974, fig 11.3-4). This example is yellow glazed becoming green towards the bird's body. It still works. It comes from a layer of ?demolition debris (LWC G20) in which two clay pipes of 1660-80 were the latest finds, but earlier coins and numerous cross-joints with Stratified Group 18 (*c* 1625-50) suggest the whistle derives from this group. Bird whistles are fairly rare in Britain, though others have been found besides the few examples known from the 1970s (*ibid*; Mytum 1978).

## Beauvais earthenwares (Fabric 30)

[Fig 174.11, Fig 175.12-16]

Weight: 0.215 kg

Number of sherds: 14

EVEs: 0.45

Fine white earthenware was produced at Beauvais in northern France during the later 15th and 16th centuries and moderate amounts were exported to Britain (Hurst *et al* 1986, 106-116). Only two sherds of the monochrome green-glazed ware came from the excavations representing perhaps a single vessel (Fig 175.12). These have been identified as probably coming from a costrel with a fragmentary circular rosette medallion (Alan Vince, pers comm). The context in both cases is a general 17th-century one. A small yellow glazed Beauvais jug from Pelham's Lane in Colchester bears an applied circular medallion with the royal Tudor arms (Fig 174.11; published previously in Hurst 1970-71, fig 2 & pl 1). Another example, also in Colchester Museum, is identical in form to the latter but has a green glaze and a fragmentary pellet-bordered roundel also with the royal arms (CM OS.7.1944).

A minimum of ten Beauvais sgraffito dishes is represented. Eight of these (including Fig 175.13-16) are decorated in the single sgraffito technique, whereby designs have been incised through an internal covering of red slip to contrast with the underlying white fabric (Hurst *et al* 1986, 110). All of these are decorated on the inside of the flanged rim, except for one fairly large rim fragment which shows no

sign of decoration except for a pair of scored lines on the external beaded lip (not illustrated: LWC C27). Two small rim sherds carry inscriptions in typical Beauvais style but these are too small to be intelligible (not illustrated; LWC CF2; LWC G4). Only two small dish sherds are decorated by the double sgraffito technique (*ibid*), where the inside of the vessel was covered first with a red slip and then with a white slip, through which designs were then incised to reveal the red (not illustrated: LWC LF78 & COC L18). These also have green-glazed areas unlike the single sgraffito dishes.

Production of Beauvais sgraffito began c 1500, and it was exported to Britain throughout the 16th century until its eclipse by slip-trailed wares in the 17th century (*ibid*, 112). Very few of the dishes from Colchester, however, come from contexts datable any closer than the late 16th (possibly) and the 17th centuries.

### Beauvais stoneware (Fabric 45J)

[Fig 175.17]  
Weight: 0.010 kg  
Number of sherds: 1

Stoneware, with a light grey fabric identical to Siegburg stoneware, was produced at Beauvais in north France from the late 14th century and reached its peak in the late 15th and early 16th centuries (Hurst 1986, 105-6). Small quantities have been found throughout Britain. A single fragment of a tubular handle (Fig 175.17) was found on these excavations (identification confirmed by John Hurst, 1987). This is slightly tapered. The exterior is covered with a thick clear (ash?) glaze with cloudy streaks and a large brown patch. It came from a post-medieval brick soakaway with 17th-century pottery and some modern contamination.

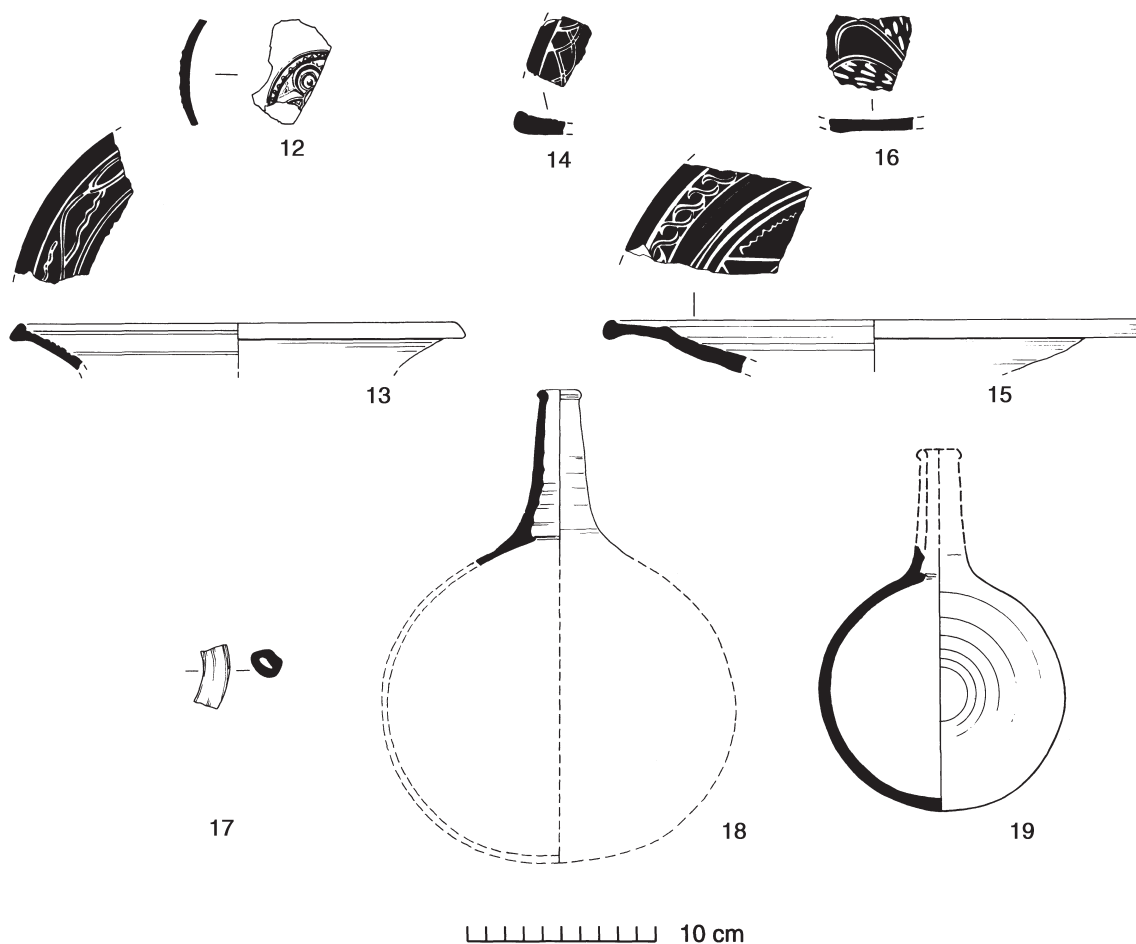

Fig 175 French wares: Beauvais earthenware costrel (no 12); Beauvais sgraffito dishes (nos 13-16); Beauvais stoneware handle (no 17); Martincamp flasks (nos 18-19). 1:4.

### Martincamp flasks (Fabric 43)

[Fig 175.18-19]

Weight: 1.165 kg

Number of sherds: 36

EVEs: 4.00

Martincamp lies close to the north French coast between Dieppe and Beauvais. Slender necked globular-bodied earthenware flasks were produced here perhaps from the last quarter of the 15th century until well into the 17th century and are common finds on British sites (Hurst *et al* 1986, 102-4). Only flasks of type III (Fig 175.18-19) were found on the sites covered in this volume. These have a hard, fairly fine orange-red fabric, without glaze, and with spherical bodies. A minimum of eleven vessels are represented. This type is common in the 17th century though it overlaps with the earlier types I and II which were common in the 16th century.

Although outside the brief of this volume, it is worth mentioning a stone-lined pit on the Angel Yard site which, in addition to sherds of type III flasks, produced the only sherds of type I and II flasks known from recent excavations in the town. The contents of this pit (40.86 F76), including a dated stoneware medallion of 1585, suggest a date of *c* 1600 if not slightly earlier for the whole group. Type I flasks have a possible date range of *c* 1475-1550 and have a fine off-white fabric and flattened rather than spherical bodies. Type II flasks date to the 16th century and have a dark brown stoneware fabric with a spherical body slightly flattened on one side (*ibid*). Up to three individual flasks of type III came from another relatively early pit group of *c* 1625-50 (not illustrated: Stratified Group 18, *see* p 334). Figure 175.19 was found complete, lacking only its neck, in a pit containing several clay pipes of *c* 1660-80.

In addition to the examples described above, there are three other Martincamp flasks in Colchester Museum. One of these (unaccessioned) has a complete flattened body of type I (as *ibid*, fig 47.142) though with a brown fabric; the other two are large neck sherds of type I flasks in off-white

fabrics (CM 461.27(29?); 421.39). A cache of up to thirty gourd-shaped bottles, possibly Martincamp flasks, was found in Colchester in 1776 and has been mentioned earlier (*see* pp 19-20).

### Normandy stoneware (Fabric 45N)

Weight: 0.210 kg

Number of sherds: 1

EVEs: 0.08

Normandy stoneware is rarely found in England where its distribution is mainly coastal. Most examples found here date from the 16th to the 18th centuries (Hurst *et al* 1986, 100-102; Burns 1991). It is becoming increasingly evident, however, that the later products of this industry were extensively imported into England during the 19th and earlier 20th centuries in the form of butter and margarine containers for retail sale. The evidence for this will be presented elsewhere.

The fabric of the Colchester piece is a smooth to silty, dense, dark purplish-brown stoneware with a paler brownish-yellow core. It is unglazed though the outer surface has a purplish vitreous 'bloom'. Purplish fabrics are characteristic of the Bessin group of potteries in the Cotentin Peninsula, Lower Normandy (Burns 1991).

The excavated example is a heavily-beaded rim (not illustrated; diameter around 390 mm) which probably comes from a butter jar. Alternatively it could come from a large larding or salting jar (a *sinot*; *ibid*, no 112, from *c* 1680 onwards). There is no good dating evidence for the piece itself which is unstratified. However, it seems likely that the piece was used as metalling in the yard of the former Angel Inn, the uppermost levels of which contained mostly late 18th- and some early 19th-century pottery.

## Chapter 8. Low Countries wares

### An outline of contact with the Low Countries

[Fig 173]

Colchester's Court Rolls and many other historical sources contain an abundance of references to contact with the Low Countries (see Introduction, pp 18-19). Flemish ships were calling at Colchester's port at least by the 1340s, and in the following decade a number of Flemish families, probably weavers, settled in the town (Britnell 1986, 13, n 31, 72). Thereafter references to 'Flemynges' and 'Duchemen' in the town steadily increase, and their numbers were swelled in the 16th century by a large influx of Protestant Dutch refugees (Stephenson 1978, 57). By the early 17th century, nearly all foreign goods reaching Colchester were being funnelled through the Low Countries, and in some years the number of Dutch ships docking here was often greater than those from London (Davis 1981, 16-17). The Dutch established their own community and Dutch-speaking church which lasted into the 18th century. Most of the 17th- to 18th-century trade was conducted through Rotterdam, from whence Colchester received large consignments of Dutch bricks and other goods for redistribution to Maldon and other coastal towns (Willan 1938; *VCHE*, 9, 84-5).

A list of custom duties of the reign of Richard II (1377-99) describes those goods coming into Colchester's port at the Hythe which were to be taxed. This includes 'Flandres tyl, j mille jd' (Flemish tile, taxed at a penny per thousand), and further down 'pottys of erthe, a carful, jd' (*Oath Book*, 9-10). This latter is most likely a reference to earthenware pots from the Low Countries: if pots were reaching Colchester's port in numbers large enough to be worth taxing, then they were almost certainly not the trickle of pots from other areas of England that occasionally found their way to Colchester, but must represent some more substantial source. Rhenish stonewares can be discounted as these appear to be mentioned separately in the same list ('potts de Ryne'), so it seems reasonable to assume that 'pottys of erthe' refers mainly to imported pottery from the Low Countries. Before the arrival of red earthenwares, imported pottery from the Low Countries is represented in Colchester by a few yellow glazed pitchers from Andenne and by a few sherds of Brunssum-Schinveld type. Decorated and green glazed 'Aardenburg ware' jugs have not been recognised among the excavated material. Dunning has published a small, plain, collared-rim cooking pot from Colchester as a likely medieval import from the Low Countries (Dunning 1976, fig 1.5; the fabric is in fact a dirty off-white rather than grey or brown). The base of a Low Countries greyware jar with pulled feet (CM 128.1975) was found at Salcott Creek seven miles (11.2 km) south of Colchester, but none has been identified from the town itself.

### Brunssum-Schinveld ware (Fabric 14B)

[Fig 176]

Weight: 0.185 kg

Number of sherds: 4

The fabric has a pale creamy buff colour and a sandwich core which, like surface colour, may vary from very pale brown to pale grey depending on firing conditions. When highly fired, the earthenware fabric has something of the qualities of a near-stoneware and closely resembles Pingsdorf-type ware. It is quartz with occasional much larger inclusions of soft red iron oxide and a scatter of elongated vesicles. The surface feel, like Pingsdorf, is quite rough and sandpaper-like.

The Brunssum-Schinveld pottery industry was located in Dutch Limburg, where red-painted pale-bodied earthenwares were produced from the 11th century until at least the 13th century (Janssen 1983, 127). These products have many stylistic and technological affinities with Rhenish products of the same period. Spouted pitchers and jars appear to be the most common forms found in Britain, usually in 12th-century contexts.

Four sherds have been identified in Colchester, three of which are red-painted; two are body sherds (not illustrated). Figure 176.1 (LWC KF217) comes from the frilled base of a jar or pitcher. The thumbing is quite deep and angular and above this there are vertical wiping marks; internally these marks are more random. Figure 176.2 (LWC K109) may be a rim, but it is so irregular that it could equally be part of a broad strap handle. It is strongly ribbed or rilled with two blobs of red paint on the 'rim' and a further trace of paint, possibly a stroke, at right-angles to the 'rim'.

The frilled base occurs with local early medieval coarsewares (Fabric 13) and is quite compatible with a 12th-century dating. A further body sherd (1.81 JF18) occurs with later greywares (Fabric 20) and a possible London ware sherd (Fabric 36) where a late 12th- or a 13th-century date seems likely. The remaining sherds are residual.

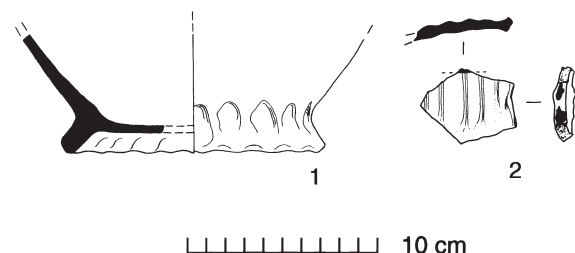

Fig 176 Brunssum-Schinveld ware: jar or spouted pitcher base (no 1); strap handle with red paint (no 2). 1:4.

During its main period of importation into Britain in the 12th and early 13th centuries, Brunssum-Schinveld ware was contemporary with, if somewhat rarer than, similar wares such as Pingsdorf and Paffrath. All three wares are scarce in Colchester although, interestingly enough, the proportions in which they occur are remarkably similar, representing a minimum number of three or four vessels each.

### Andenne ware (Fabric 17)

[Fig 177]  
Weight: 0.480 kg  
Number of sherds: 34

Andenne ware has a fine white-buff fabric tempered with quartz sand and sparse coarser inclusions of (magnetic) red iron oxide which may appear as darker specks or streaks in the yellow glaze (Verhaeghe & Janssen 1984, 18). Only base and body fragments were found on the excavations covered by this volume, but a collared jar rim has been found on subsequent excavations (40.86 L160). Figure 177.1 is a typical sharply angled base most probably from a globular jar. There are knife-trimming marks all around the lower area and similar marks internally. Glaze is limited to a few external and a few larger internal pale yellow splashes, suggesting that only the upper part of the vessel was uniformly glazed. Three other sherds have lozenge roller-stamping (not illustrated), one of which came from the same pit as the base and may be part of the same vessel. There are only two sherds from jars with thumbbed vertical strips. A few examples are rilled, and one very small sherd (CPS U/S, not illustrated) is grooved and may come from a bowl as it is glazed on both sides.

This ware takes its name from its source area at Andenne in eastern Belgium where it was produced from the 11th century until the 13th century (Borremans & Warginaire 1966). Its distribution in Britain is predominantly along the east coast where it occurs particularly in contexts of the 12th and 13th centuries (Brooks & Hodges 1983). Colchester's Andenne sherds represent a minimum number of about fourteen or fifteen vessels. Just over a third of the sherds were found in contemporary 12th- to 13th-century contexts. One roller-stamped sherd was found in a robber

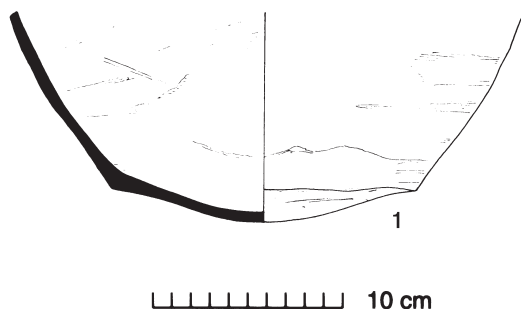

Fig 177 Andenne ware: jar or spouted pitcher base (no 1). 1:4.

trench (CPS F83) of Period 2.2-3 (c 1100-1150). By weight, 7% of the ware (4 sherds) occurs in Period 2.2-3 where it comprises 0.5% of the assemblage, but 85% of the ware (16 sherds) occurs in Period 2.4 where it comprises 3.6% of the assemblage.

### Miscellaneous early medieval Low Countries white wares (Fabric 17X)

Weight: 0.035 kg  
Number of sherds: 3

This small category has been invented to accommodate some coarse white to buff sandy sherds with a yellow Andenne-like glaze which is iron-enriched in places. The fabric is somewhere between that of Andenne ware and Brunssum-Schinveld ware, with abundant medium to coarse inclusions of sub-angular quartz and some rare black glassy inclusions. Because of these similarities, Alan Vince (pers comm, 1987) has suggested a Belgian or north European origin. Two sherds (LWC D156 & LWC CF101) come from the shoulder area of jars or jugs; one has traces of applied strips and the other has a very prominent shoulder cordon. One other sherd (LWC DF162) is glazed on both sides and probably comes from a lid or shallow bowl. The latter was found in a robber trench which contained some local 12th-/13th-century pottery.

### Low Countries red earthenwares (Fabric 31)

[Figs 178-182]  
Weight: 24.380 kg  
Number of sherds: 793\*  
EVEs: 16.43\*

Red earthenware was produced at numerous locations throughout the Low Countries between the 13th century and fairly recent times. Already it is present in London deposits of the late 13th century (Vince 1985, 58), but it only becomes common from the mid 14th century onwards. The most recent English summary of this ware and its variations is in Hurst *et al* (1986, 130-53). In general the fabric is hard red and finely sandy though there may be colour variations from light orange to dark and brownish-red. Subtle textural variations are also evident. The clear lead glaze derives its colour from that of the underlying fabric and normally appears a golden- or brownish-orange colour. Where it is thick, the glaze is often crazed and its application tends to be irregular in the earlier examples but becomes increasingly more regular in the post-medieval period. It is often difficult to distinguish sherds of this fabric from the finer varieties of sandy medieval and in particular the post-medieval redwares of Essex (Fabrics 21 & 40). This problem is considered more fully in the section on Fabric 40 (see pp 191-2). Fortunately the influence that imported Low Countries wares had on local potters does



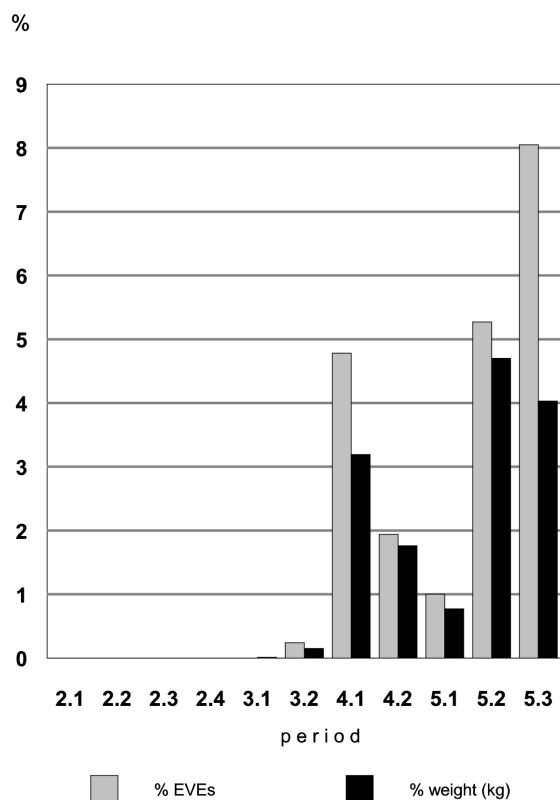

Fig 178 Low Countries red earthenwares (Fabric 31 & 31A): bar chart showing percentages in stratified contexts (ceramic periods).

not appear to have resulted in the wholesale imitation of these vessels, and it is normally possible to make distinctions on the basis of vessel form. It is more difficult, however, to distinguish between true Low Countries slipwares and the late medieval/early post-medieval slipware known as Guy's Ware (Fabric 55) which was produced in London and which reached Colchester in small quantities. This was strongly influenced by Low Countries forms and the fabric in some cases appears very similar.

Given Colchester's important trade links during the post-medieval period with Holland, and Rotterdam in particular, one of the more likely candidates for the source of Colchester's later redwares was the important pottery-producing port of Bergen-op-Zoom located on one of the deep inlets south-west of Rotterdam (Groeneweg 1992).

The earliest possible occurrence of Low Countries red earthenware in Colchester is a single sherd in Period 3.1 (MID CL114). This came from a layer containing a virtually unworn farthing of Edward I, most likely lost between 1280-1320 (CAR 4, 66). The sherd, however, is rather small and has a regular glaze on both sides, and one could argue that it might be post-medieval and intrusive. Part of a tripod-footed base occurs in Period 3.2 (c 1250/75-1400), and by Period 4.1 the ware occurs commonly. Several sherds occur in contexts associated with the refurbishment of the town wall c 1382-1421 (Stratified Group 9), and from the 15th until the late 17th or early 18th centuries the fabric is particularly common.

*Jars: cauldrons and pipkins* (Fig 179.1-9; Fig 180.10-13)

These are the commonest forms encountered. Cauldrons are cooking pots with tripod feet and a pair of handles (eg Fig 179.2), whereas pipkins have one handle and tend to be smaller, sometimes with a pouring-lip (eg Fig 179.4). Both have the same basic form and both were used for cooking as shown by their frequently sooted bases. Those shown here illustrate quite well the development of these forms between the 15th and late 17th/early 18th centuries, largely agreeing with the outline given in Hurst *et al* (1986, 130-35). Earlier types (Fig 179.1, 4-5) tend to have more globular bodies, simple rims and a low basal carination. (They also have angular or arched handles, not adequately represented here.) Figure 179.1 comes from Stratified Group 10 of c 1400-50+ (see p 323). This pit group also produced a rim (Fig 222.6) which is virtually identical to the largely complete pipkin Figure 179.4 (Period 4.1) which was itself found with a complete Saintonge *pégau* (Fig 174.7), confirming the early 15th-century date of these redwares. Somewhat later, Figure 179.5 came from a late 15th- or early 16th-century pit with Raeren drinking jugs. On all cauldrons, decoration is almost entirely confined to ribbing or grooving on the shoulder, but in the mid 16th century a thumbled strip was sometimes applied below the rim (Fig 179.6, though this is rare in Colchester). The post-medieval forms become increasingly less globular and become wider in relation to their height, while the basal carination moved up to a mid-point on the vessel profile (Fig 179.2-3, 7-8). Handles become larger and more rounded in profile. Figure 179.2 (Stratified Group 20, c 1650) is of later 16th-century type (*ibid*, fig 59.184). More complex flanged rims, perhaps designed to receive a lid, first appear in late 16th-century groups in Colchester and become common from the early 17th century onwards (Fig 179.2, 7, 9 & Fig 180.10). Such rims are represented in Stratified Group 16 (c 1550-1600, not illustrated), and rims as Figure 179.2-3 and Figure 180.10 occur in Stratified Group 18 (c 1625-50). The latest cauldrons illustrated here (Fig 179.9 & Fig 180.10) are exceptions to the rule in that they show a return to the medieval globular-bodied form with low basal carination, but the complex rims and almost total glaze coverage declare them to be late. Figure 179.9 comes from Stratified Group 21 (c 1680-1700). Figure 180.10 (MID F387) was found virtually whole and was clearly fired upside-down. It was found in a large pit with an early-mid 18th-century tin-glazed punchbowl, although most of the associated pottery appeared to be of the 17th century.

Other types of jar occur but are less common (Fig 180.11-13). Figure 180.11, which could be a pipkin, was found with a mid 16th-century Cologne stoneware mug. Figure 180.12 has a pair of diametrically-opposed perforations (post-firing) through the rim, presumably to allow suspension. The frilled foot-ring of Figure 180.13 is very uncommon and is glazed only on the underside which also displays kiln scars. This comes either from a jar or pitcher probably of the 15th century (Janssen 1983, figs 9.20:2 & 9.21:1).

*Skillets* (Fig 180.14-16)

These are less common than dishes from the excavations but predate them. Around a dozen examples of various dates are known from the town. All examples are clear glazed on the inside only, and most show signs of sooting. Figure 180.14 and 15 are closely paralleled by skillets from the early 15th-century kiln at Utrecht (Janssen 1983,

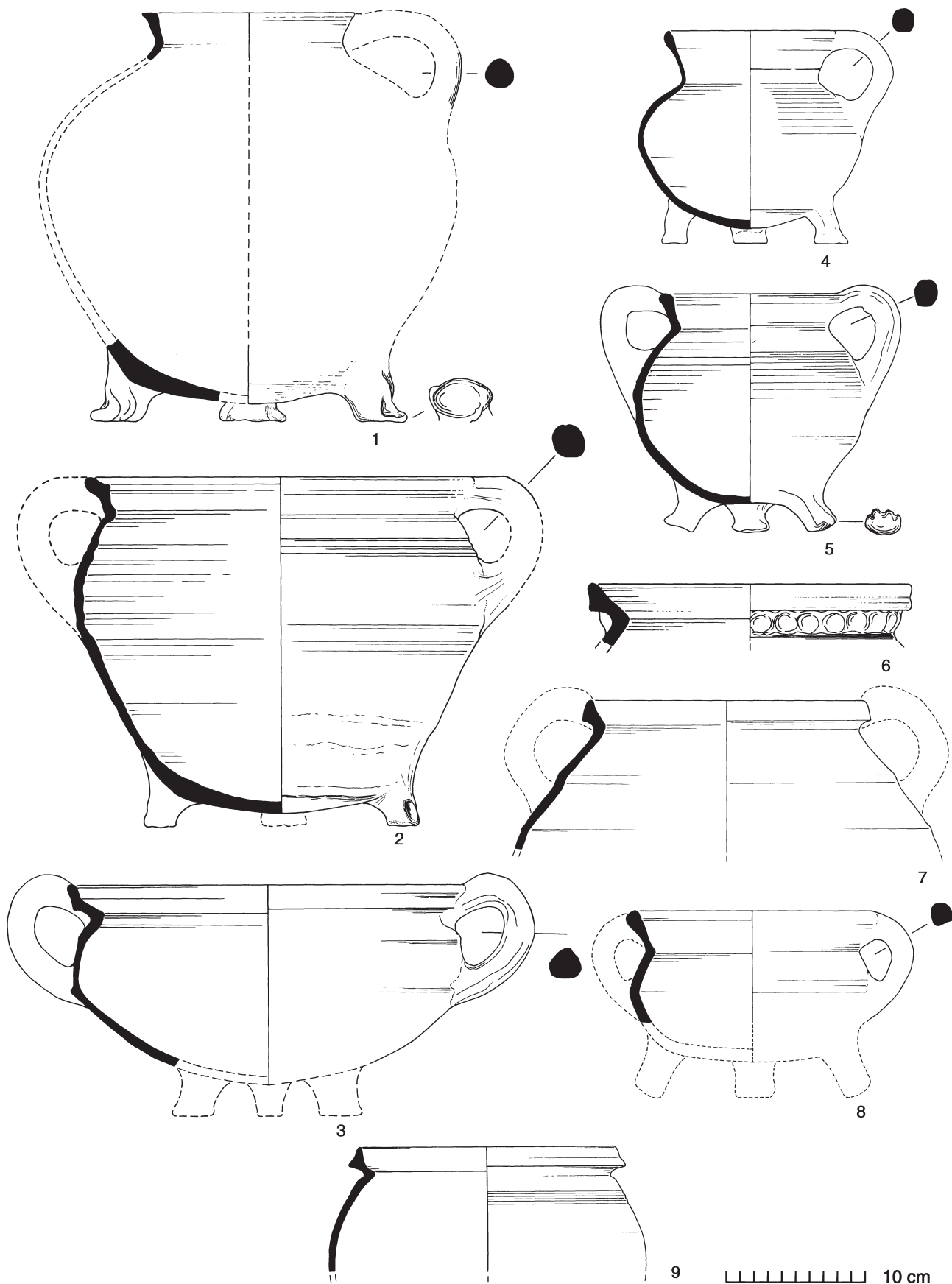

Fig 179 Low Countries red earthenwares: cauldrons and pipkins (nos 1-9). 1:4.

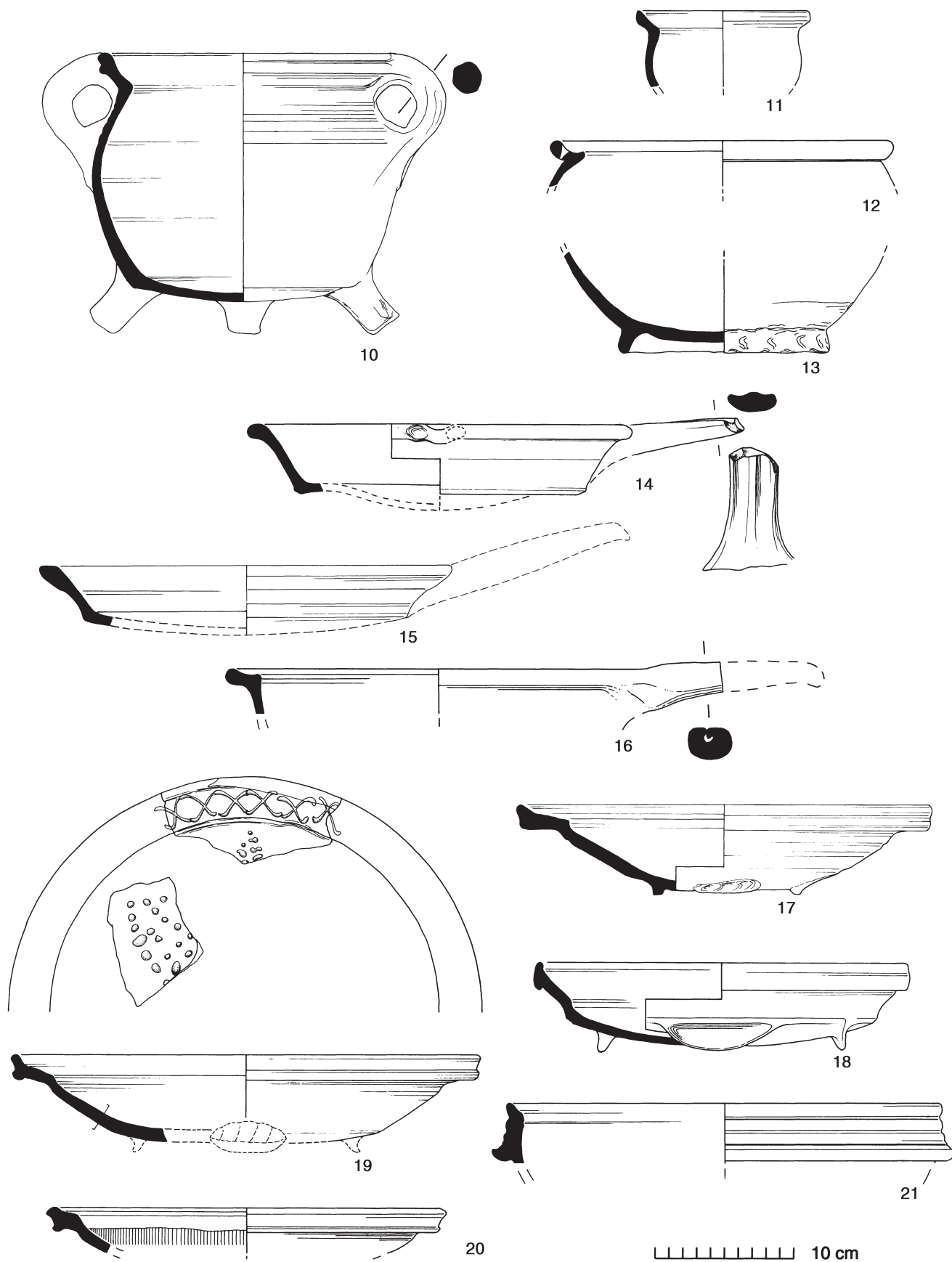

Fig 180 Low Countries red earthenwares: cauldron (no 10); miscellaneous jars (nos 11-13); skillets (nos 14-16); dishes and bowls (nos 17-21). 1:4.

fig 9.13). Some of these have flat as well as sagging bases and the latter may have tripod feet. Figure 180.14 comes from Stratified Group 10 of c 1400-1450, although a very similar example occurred in a pit of c 1625-50 along with a large number of other vessels in this fabric, all apparently contemporary in their context (not illustrated, Stratified Group 18). Some development, however, is seen in Figure 180.16 which also comes from a pit of this date (Stratified Group 17). The rim is more developed and the handle folded and almost tubular; it may well have had tripod feet.

#### *Dishes and bowls* (Fig 180.17-21; Fig 181.22-5)

Dishes are the commonest form present after jars (ie cauldrons and pipkins). All of those from Colchester are post-medieval. Slipware dishes with flanged rims and pulled feet appeared in the Low Countries in the 14th century but were uncommon before c 1400 (Hurst *et al* 1986, 146). Those illustrated here, however, date to the late 16th and 17th centuries. Figure 180.19 (Stratified Group 18, c 1625-50) is probably an example of North Holland slipware although its decoration is restricted to a thick trailed slip without the usual touches of green glaze. In Holland, dated examples of large slipware dishes of this type range from 1573 to 1607 (*ibid*, 157, eg fig 71.231). The majority of dishes from the excavations are plain, but examples with an internal covering of white slip are known (Fig 180.17, 20). The slip ends just below the rim, and on Figure 180.20 the slipped area has been covered with a pale green glaze (Stratified Group 17, c 1625-50). Figure 180.18 (unstratified) is paralleled by a more fragmentary example from a context of c 1500-1525 (Fig 226.9, Stratified Group 13).

Wide deep bowls are much less common than dishes. A distinctive 16th-century bowl type (Fig 180.21) is sharply carinated with an external cordon and deep grooving (Platt & Coleman-Smith 1975, fig 199.1219, 1224 & 1226). A Guy's ware bowl of this form came from a context of c 1525 (Fig 127.1). Flat-based dishes with broad flanged rims and occasionally with slip-trailed decoration appear to date from the later 17th and early 18th centuries (Fig 181.22-25). The slip decoration on Figure 181.22 is sparingly flecked with copper-green, otherwise it differs little from Metropolitan slipware. Figure 181.23, with its thick high-relief slip, is more characteristic of Dutch slipware. It might just as easily have had pulled feet as a flat base.

#### *Strainers* (Fig 181.27)

Strainers or colanders were rarely traded to Britain (Hurst *et al* 1986, 136), but local redware strainers at Norwich were clearly influenced by Dutch examples (Jennings 1981, fig 78) and so perhaps at Colchester (see Fig 148.179). They sometimes appear in Dutch paintings of the 17th century, for example in 'A sleeping maid and her mistress' painted in 1655 by Nicholas Maes. A fragment from a flat-based strainer at Colchester occurs alongside clay pipes of 1660-80 (LWC G20). Figure 181.27 is quite possibly another example of this form. Although the base itself is largely missing, a vestige of a perforation remains and there are traces of a handle and possibly of tripod feet. The outside of the vessel is heavily sooted. This came from the same 18th-century context as the cauldron Figure 180.10.

#### *Porringers and drinking vessels* (Fig 181.26, 28-29)

A small number of fairly small but deep carinated bowls may have served as porringers or drinking vessels, or both. Figure 181.28 is one of three identical vessels found in the same pit. All three are covered inside and out with the same greenish clear glaze with green flecks probably caused by a reducing kiln atmosphere. The corrugated upper half has a helical twist produced by a slowly revolving wheel and all three vessels were fired upside-down. Small carinated vessels with flilled foot-rings such as these occur in the 16th and 17th centuries (Janssen 1983, fig 9.21:4; Jennings 1981, fig 55.928). These three examples, however, come from a puzzling late 17th- or 18th-century context. A virtually complete tin-glazed dish of c 1630-40 (Fig 162.23), from the same pit, suggests that some vessels from this context could already have been around a century old when discarded. Another cup has a pedestal base with external blotches of white slip under a clear glaze (Fig 181.29). This was found with early 16th-century Colchester ware forms. A complete Dutch porringer, square in plan and with a pinched handle, is kept in Colchester Museum. This was probably found in Colchester but is unprovenanced (CM Acton Coll 821; not illustrated, as Jennings 1981, fig 55.940).

The mug or drinking jug (Fig 181.26) is clearly an imitation of German stoneware forms. A greenish glaze covers the vessel which has a coarser fabric than usual and resembles fabric samples from Aardenburg (David Gaimster, pers comm, 1986). The context is late 16th century.

#### *Dripping pans* (Fig 181.30-31)

These are uncommon. There is a single example of a dripping pan of Utrecht type from a context of c 1525-50 (Fig 181.30, Stratified Group 15). This type of form appeared in the 14th century. Originally it would have had feet on the handled side and would have stood at a slight tilt (Hurst *et al* 1986, fig 61.201). A few other fragments come mostly from featureless bases, but a broad flanged rim (Fig 181.31) occurs in a context of c 1680-1700 (Stratified Group 21).

#### *Curfews* (Fig 182.32-33)

There are two fragments from Utrecht-type curfews (fire-covers) in this fabric, both unglazed (Fig 182.33). These would have been broad bell-shaped vessels with pulled 'feet' around the top and a bucket-like handle. Figure 182.33 has a small perforation near the apex. This was the type of curfew produced by kilns at Utrecht in the early 15th century (Hurst *et al* 1986, fig 61.204), and a 15th-century date is compatible with the pit context which also produced a Langerwehe jug (Fig 188.2) and local wares of this date. In addition to medieval types intended to cover an open fire, two post-medieval type upright curfews are known from the town. These were intended to stand at the chimney breast rather like a modern fire guard. Examples in North Holland slipware generally date to 1575-1625 (*ibid*, pl 27, fig 82.249), but a plain example is shown in a painting now in the Ashmolean Museum by Jacob Vrel (active 1654-62) entitled 'The little nurse'. A large portion of a plain curfew (Fig 182.32), now in Colchester Museum, was found in Wyre Street, Colchester. This is of the usual half-bell shape with a central vertical handle flanked by two incised rosettes in which the centre is a broad circular perforation. The vessel is edged with a

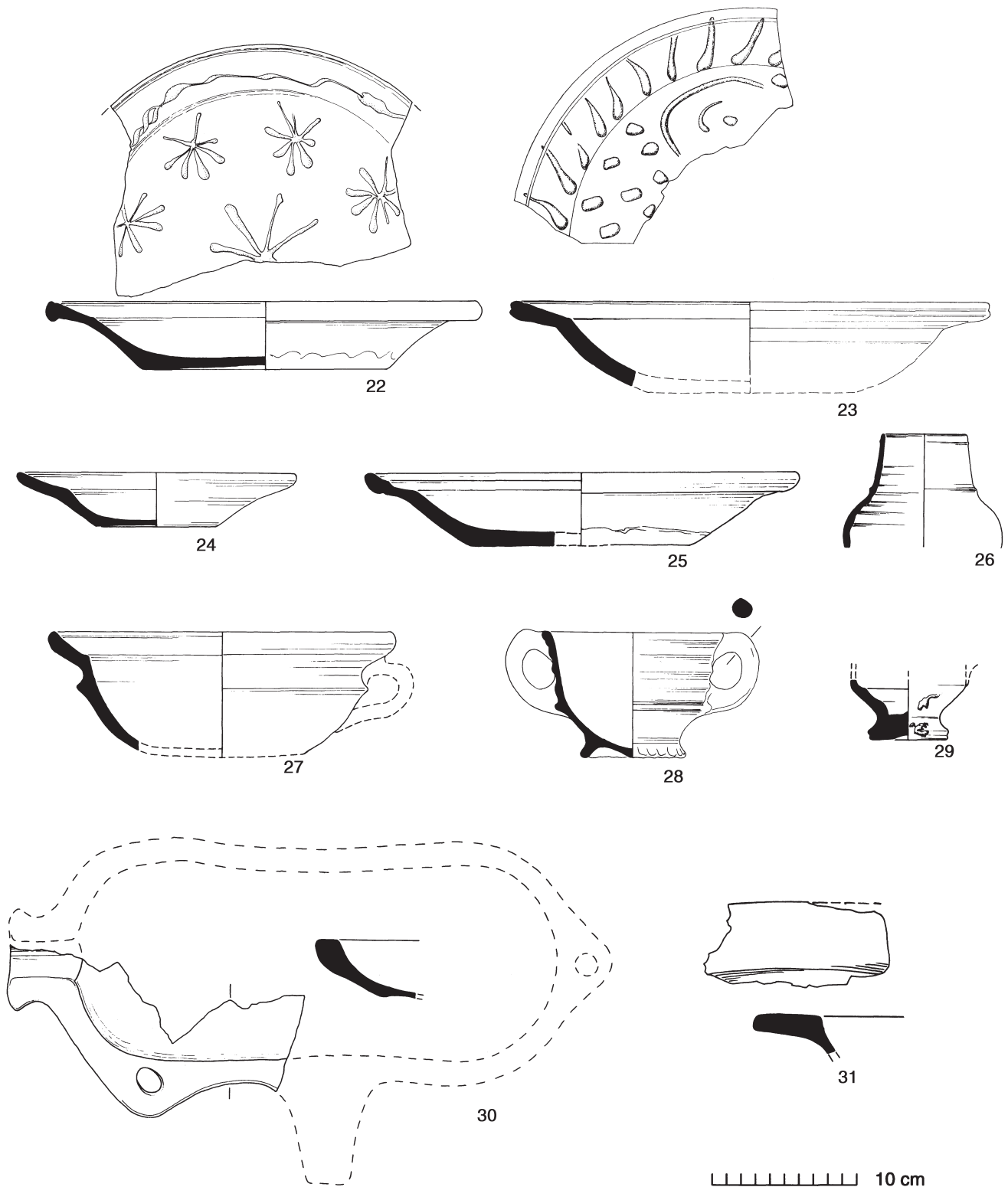

Fig 181 Low Countries red earthenwares: dishes (nos 22-5); drinking jug imitating Raeren stoneware (no 26); strainer (no 27); porringers or drinking vessels (nos 28-29); dripping pans (nos 30-31). 1:4.

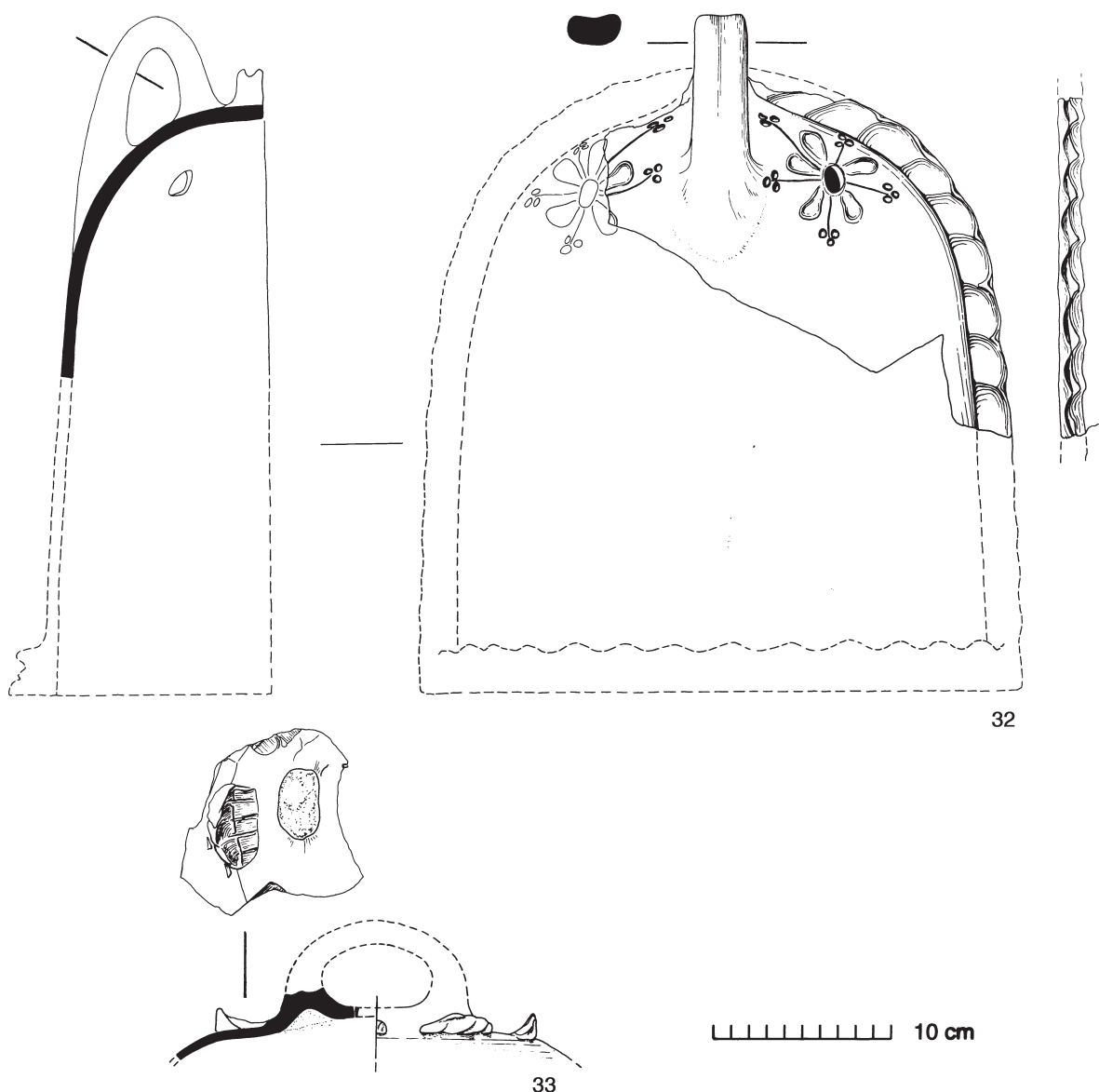

Fig 182 Low Countries red earthenwares: curfews (nos 32-33). 1:4.

thumb-pierced rim and is covered externally with a light orange glaze. Part of an identical glazed rim in a fine pale orange fabric was found in Stratified Group 17, c 1625-50 (Fig 230.14). Two probable curfews in North Holland slipware are also known from the excavations (see p 274).

*Miscellaneous*

The earliest slipped sherds in Low Countries red earthenware occur in Stratified Group 10 (c 1400-1450). These are too small to illustrate but one comes from a small globular-bodied vessel covered with an external white slip under a clear glaze. Another sherd comes from the knife-faceted area of a vessel with external traces of slip. From post-medieval contexts, there are also one or two tripod pipkin or skillet fragments with an all over internal white slip which extends over the rim (eg LWC A24, not illustrated).

**North Holland slipware (Fabric 31A)**

[Fig 183]  
 Weight: 2.555 kg  
 Number of sherds: 120\*  
 EVEs:4.37\*

This has a similar fabric to ordinary Low Countries red earthenware being hard and sandy, but it has a consistently bright pale orange colour and a correspondingly bright glossy clear lead glaze. It was produced in the southern part of the province of Noord Holland from the late 16th until the 18th century. Dated examples range from 1573 to 1711 (Hurst *et al* 1986, 154-68). Decoration was carried out in trailed white slip with frequent highlights of green glaze over certain areas of the design.

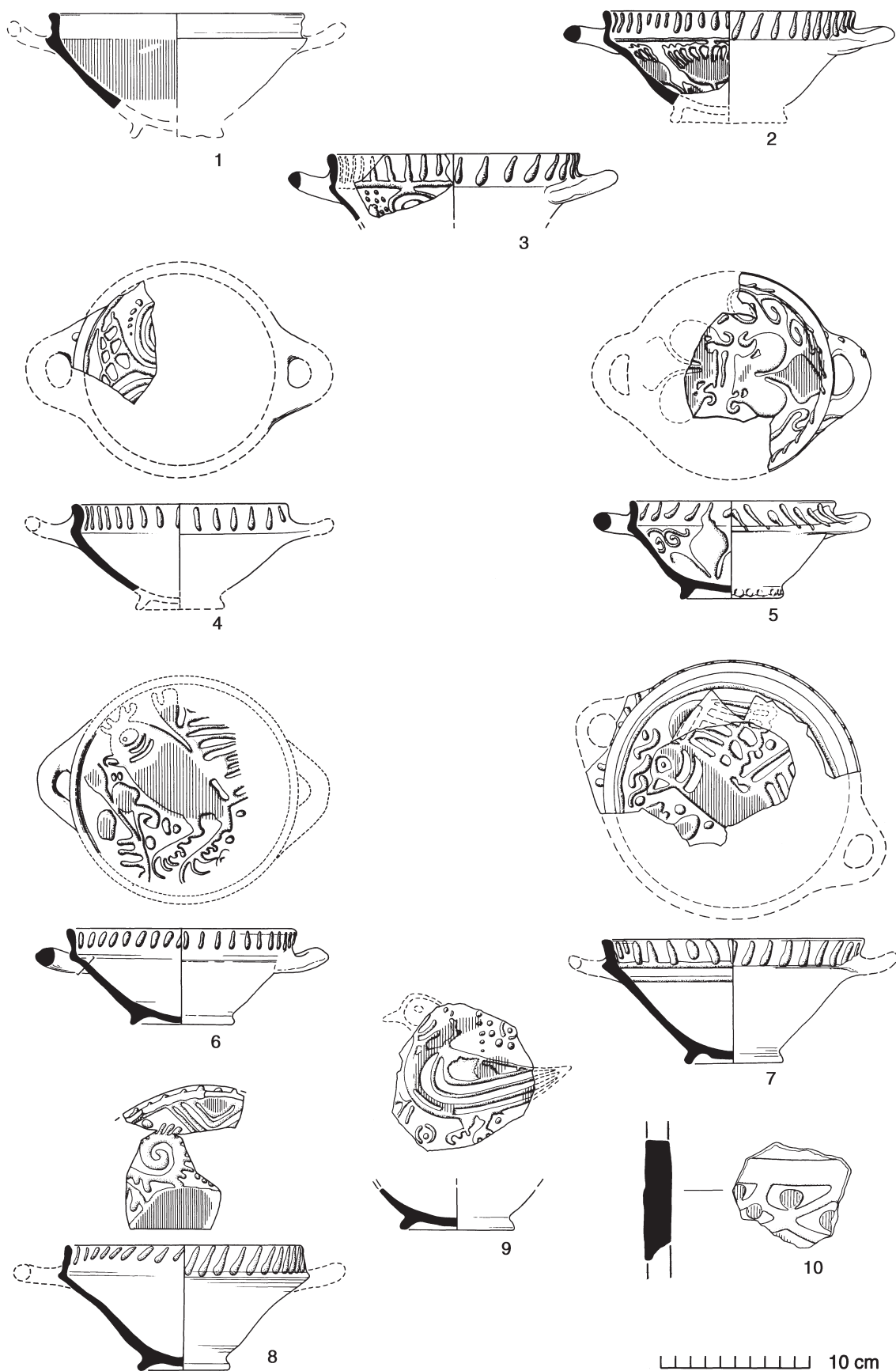

Fig 183 North Holland slipware: carinated bowls (nos 1-9); curfew fragment (no 10). 1:4, except no 10 at 1:2.

Virtually the only form found in Colchester is the small carinated bowl with a pair of horizontal loop handles and a foot-ring base which is often lightly frilled (Fig 183.1-9). The only certain exceptions are two sherds from two separate fairly thick-walled vessels, probably curfews, glazed on the outside only. One of these (Fig 183.10) has a scale-like decoration with a central green dot in each scale. The other has broad external slip bands with green painting (LWC G20, not illustrated). A few dishes considered along with the general Fabric 31 category might also belong to the North Holland slipware tradition on the basis of their slip designs or an internal covering of green glazed white slip (Fig 180.19-20 & Fig 181.22-23). But the distinction is unclear and they lack the colour and exuberance of more classical pieces. An exception, however, has been made in the case of Figure 183.1 (Stratified Group 21, c 1680-1700), which is included here on the basis of its similar fabric and form.

The common carinated bowls are of a fairly standard size with diameters of 140-160 mm being especially common. All are glazed internally and externally over the rim and occasionally lower than this. Whatever the internal decoration, the rims of all examples are decorated inside and out with vertical or oblique slip dashes. The types of decoration found on the inside include spirals and geometric designs (Fig 183.3-4), fleur-de-lis (Fig 183.5), rosettes and flowers (Fig 183.2), and birds including doves (Fig 183.9) and particularly cockerels (Fig 183.6-7). None occurs here in contexts earlier than c 1625-50 (Fig 183.5; Stratified Group 18) and most of them, particularly the cockerel bowls, occur in later 17th- and 18th-century contexts.

### Low Countries white earthenwares (Fabric 23C)

[Fig 184]  
Weight: 0.335 kg  
Number of sherds: 23  
EVEs: 0.41

This is a fairly rare fabric in Colchester with no more than

seven or eight vessels represented. The fabric is hard, sandy and white to pinkish-buff in colour with a clear yellow or bright green glaze, or sometimes both on different sides of the vessel. Body sherds may be easily confused with other post-medieval white wares such as Surrey Border wares and French white wares. These Low Countries white wares range in date from the 16th to the early 17th centuries (Jennings 1981, 134). Their forms behave typologically as the red earthenwares. Figure 184.1 has a typically 17th-century cauldron shape with a pinched handle and comes from a pit of this date. The inside is covered with a regular green glaze which extends outside almost as far as the base which is sooted. One small green glazed jar has a frilled rim (Fig 184.2). All the remaining illustrated vessels are clear glazed. Figure 184.3 is a drug jar. Figure 184.4 is probably from a small carinated bowl with one or two horizontal loop handles (see Fig 241.31; Stratified Group 21, c 1680-1700).

### South Netherlands *maiolica* (Fabric 46C)

[Fig 185]  
Weight: 0.090 kg  
Number of sherds: 8  
EVEs: 0.07

#### Flower vases (Fig 185.1-5)

Because of their distinctive form and decoration, one can be unequivocal in isolating this group of vessels from the less precise Anglo-Netherlands category of tin-glazed wares. Flower vases were the only form present. The eight identified sherds, from seven sites, must represent a minimum of seven or eight vessels. Flower vases are believed to have been produced in the Bruges or Antwerp area from the late 15th century until c 1575, initially by Italian settlers (Hurst *et al* 1986, 117-19). They have a fine buff fabric with an overall tin glaze and external blue or polychrome decoration. Figure 185.1 comes from Stratified Group 13 of c 1500-1525, and a handle with a blue patch (Fig 185.3) comes from

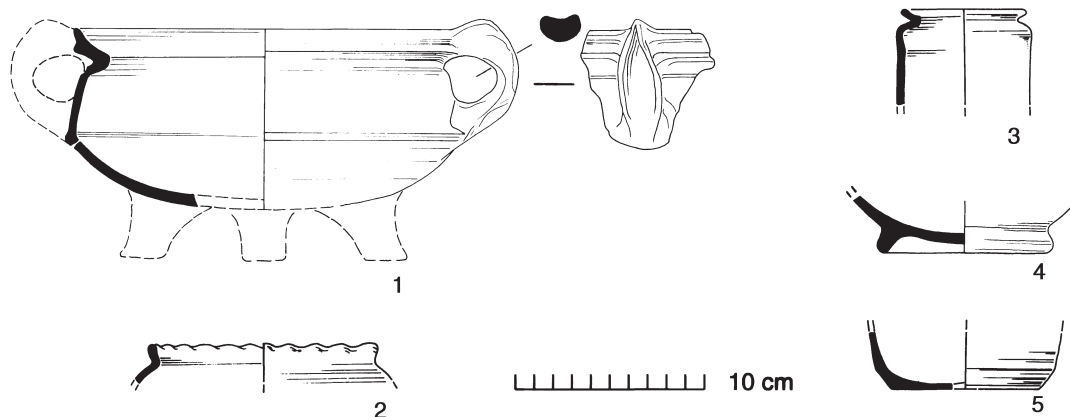

Fig 184 Low Countries white earthenwares: bichrome (green and yellow) cauldron (no 1); jar (no 2), drug jar (no 3); bowl footing (no 4); ?bowl (no 5). 1:4.



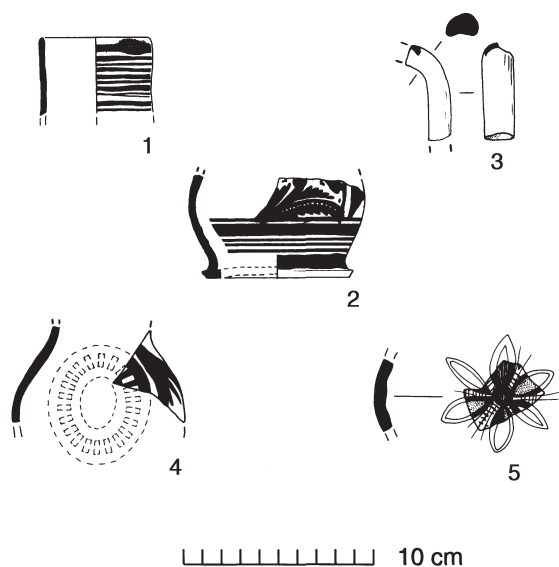

Fig 185 South Netherlands maiolica: flower vases (nos 1-5). 1:4.

Stratified Group 15 of c 1525-50. The blue ladder roundel of Figure 185.4, the foliage of Figure 185.2 and the polychrome blue, green and ochre rosette of Figure 185.5 are all typical of flower vases, although a trefoil rather than the hexafoil roundel of the latter is more usual (*ibid*, fig 54.167-8).

## Chapter 9. German and Rhenish wares

### An outline of contact with Germany

[Fig 173]

Colchester's links with Germany and the Rhineland down through the centuries have been touched upon earlier in the historical background section (*see p 17 passim*). There is little or no specific documentation for such links until the 14th century, and those connected with the Rhenish stoneware trade are detailed below. Fragments of German lava quernstones of a type in use until *c* 1000 have been found on the excavations and have been taken as evidence for the re-establishment of trade with the Continent by this date (CAR 5, 38). The sherds of Pingsdorf and Paffrath-type wares point to continuing trade, or at least contact, with Germany into the 12th and early 13th centuries.

### Pingsdorf-type ware (Fabric 14A)

Weight: 0.030 kg  
Number of sherds: 4

Pingsdorf has a very hard near-stoneware fabric with a fairly coarse sandpaper-like feel due to abundant quartz inclusions. The surfaces are normally reddish- or greyish-brown with a sandwich core; red painting is common (Dunning 1959). Pingsdorf was produced in the Rhineland, at Pingsdorf near Cologne and a few other centres along the Rhine, at least from the early 10th century to the 13th century (Hodges 1981, 84; Davey & Hodges 1983, 3). In Britain, Pingsdorf is one of the commonest imported Continental wares of the Saxo-Norman period, becoming, along with other Continental wares, more common in the 12th and early 13th centuries.

Four body sherds only were found (not illustrated), three of which are red painted. Only one is residual; the others (LWC BF54, LWC D279, LWC R30) are from the early medieval robber trenches, and are associated with 12th- or early 13th-century pottery.

### Paffrath-type ware (Fabric 18)

[Fig 186]  
Weight: 0.250 kg  
Number of sherds: 3  
EVEs: 0.41

#### Fabric

Paffrath-type ware often has a distinctive bluish metallic surface sheen, hence its designation as 'blue-grey ware' in some earlier reports. 'Blue-grey' or *blaugraue*, however, is a description applied to several distinct industries in Germany and the Low Countries. The use of this older name has now generally been dropped in favour of Paffrath-type, a name taken from one of the production centres in the lower Rhineland.

The fabric of the Colchester pieces is very hard, reduced and slate-grey resembling a low-grade stoneware. It has a sandy, fused, somewhat laminated texture. Ladles are the archetypal Paffrath form and basically consist of a small cooking pot with a hooked handle. These were commonly traded in the 12th and early 13th centuries, especially coastally (Dunning 1959, fig 32). Excavations produced fragments of three ladles (Fig 186.1-3), and a fourth is known from earlier excavations at Colchester Castle (Cunningham 1982a, fig 27.26).

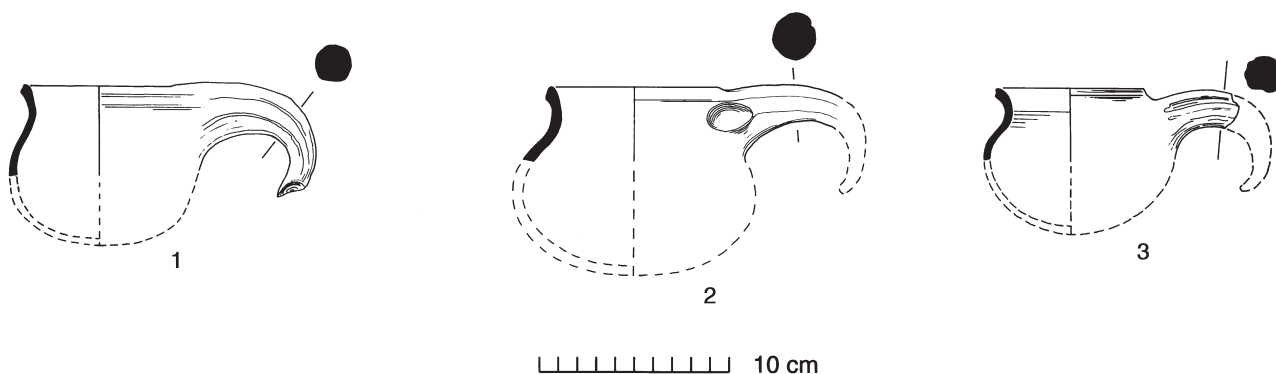

Fig 186 Paffrath-type ware: ladles (nos 1-3). 1:4.

Only one example (Fig 186.1, LWC BF18) is contemporary in its context, an early medieval robber trench. The presence of a green-glazed jug (north French?) in the same context may indicate an early 13th- rather than a 12th-century date. Figure 186.1 is thumbled below the handle, while Figure 186.2 is thumbled at the sides and has a grooved handle like Figure 186.3. All three examples have an internal depression, later plugged with clay, at the point where the handle has been attached.

## RHENISH STONEWARES

The earliest apparent reference to stoneware pots reaching Colchester from the Rhineland occurs in a medieval compilation known as the Oath Book of Colchester. Under a list compiled in the time of Richard II (1377-99), foreign goods arriving 'at the Burgh and Haven of Colchest.' are given with the appropriate customs to be levied (*Oath Book*, 6-7). These include:

'1 ame (cask) of Rynysh wyn jd  
1 tonel (tun) de Vyn iijjd  
.....  
Potts de Ryne, c., jd' (ie 1 penny per hundred)

These 'Potts de Ryne' are unlikely to be anything other than Rhenish stoneware vessels; and at this date, almost certainly Siegburg and Langerwehe stonewares. This fits very well with the archaeological record from Colchester. Both stoneware types are present in a context associated with the refurbishment of the town wall c 1382-1421 (Stratified Group 9, *see* p 322).

In the second half of the 14th century, Colchester merchants traded directly with the Baltic, particularly Prussia, but also with Germany from which linen cloth, thread and beer were obtained in exchange for Colchester cloth. Some German merchants even sailed across directly to Colchester's port at the Hythe (Britnell 1986, 63-5). But most foreign ships calling at the Hythe were from the Low Countries (*ibid*), and it was doubtless from these that Colchester received the bulk of its stonewares at this date. The Baltic ports were too distant from the various production centres along the Rhine, whereas the ports of the Low Countries lay close to the mouth of the Rhine itself. In the 15th century, particularly the 1450s and 1460s, Colchester cloth was exported to Germany in large quantities from the Hythe through the agency of German merchants of the Hanse firm (particularly from Cologne), some of whom took up residence in Colchester. Even so, the Germans chartered Dutch shipping and, for the journey to England, filled the holds with whatever exports and re-exports were available at the Dutch ports (*ibid*, 169-76). Whether the German merchants directly encouraged the export of products from further down the Rhine in their own country is unknown, but remains a possibility.

Later evidence for the importation of stonewares is given in a list of ancient tolls etc, payable to the water-bailiff of Colchester (Morant 1748, appendix to Book 2, 39-41). This ancient list was renewed and confirmed in 1574 'and again perused, approved, ratified, continued and confirmed March 2, 1668/9'. It includes:

'Maund great with Stone-pots, being a great hundred....8d  
Maund small, with Stone-pots,.....4d'

Colchester's connection with the Low Countries remained important well into the post-medieval period. The supply of stoneware re-exported from the Low Countries, however, was supplemented by the coastal re-export of these wares from London. In the surviving late 16th-century London Coastal Port Books (1579-80 & 1586-7), Colchester is shown as the largest single recipient of stonewares re-exported from London, taking 15% of these cargoes, closely followed by Exeter and Ipswich (Allan 1983, fig 4.1 & table 4.1).

Rhenish stonewares were the most important class of foreign pottery imported into Colchester between the years c 1300-1700. Importation of Rhenish stonewares reached its peak in Period 4.2, when, by the early 16th century, stonewares accounted for nearly a quarter by EVES of all pottery used in the town (*see* p 355).

### Siegburg stoneware (Fabric 45B)

[Fig 187]  
Weight: 2.210 kg  
Number of sherds: 80  
EVES: 2.96

This was produced at Siegburg, on a tributary of the Rhine in Germany, where a major pottery industry flourished between the 13th and 16th centuries (Hurst *et al* 1986, 176-84). The fabric is fine and light grey in the earlier period, normally unglazed except for rosy patches of ash glaze (*Geflamter*). In the 16th century the fabric becomes finer and white. As already mentioned, Siegburg stoneware already occurs in the town wall context of c 1382-1421, and includes both the cylindrical necked jug (*Jacobakanne*) and the funnel-necked beaker (*Trichterhalskrug*) (Stratified Group 9; Fig 220.1-4).

A single sherd of Siegburg in Period 3.2 comprised a mere 0.04% (by weight) of the assemblage. This figure rose to 1% by Period 4.1 (or 7.6% by EVES). Thereafter it declined sharply.

The biconic jug (Fig 187.1; Stratified Group 11, c 1425-75) is a typical form of the second half of the 14th and first half of the 15th centuries (*ibid*, fig 88.260). Figure 187.2 is covered externally with a lustrous dark brown wash (*Lehmglasur*) and is probably 14th century, judging from parallels (Reineking von Bock 1971, no 106). Funnel-necked beakers and jugs (Fig 187.3-5) are the commonest form from the excavations, mostly from late 15th- and early 16th-century contexts. Figure 187.3 has a thick, pale grey wash inside the funnel and extending over the rim. Applied rosette prunts are known only from a single example (Fig 187.5; c 1400-1500 — cf Hurst *et al*, 1986, pl 30 left); and Figure 187.6, from a late 15th- or early 16th-century context, is the only example of its form. An example of a late 16th-century Siegburg tankard, or *Schnelle* (Fig 187.7), comes from a 17th-century context. This displays a fragmentary, applied heraldic escutcheon. Two joining sherds from a Siegburg *Pulle* of c 1600 were also found (not illustrated). A small decorated Siegburg *Trichterhalskrug*,

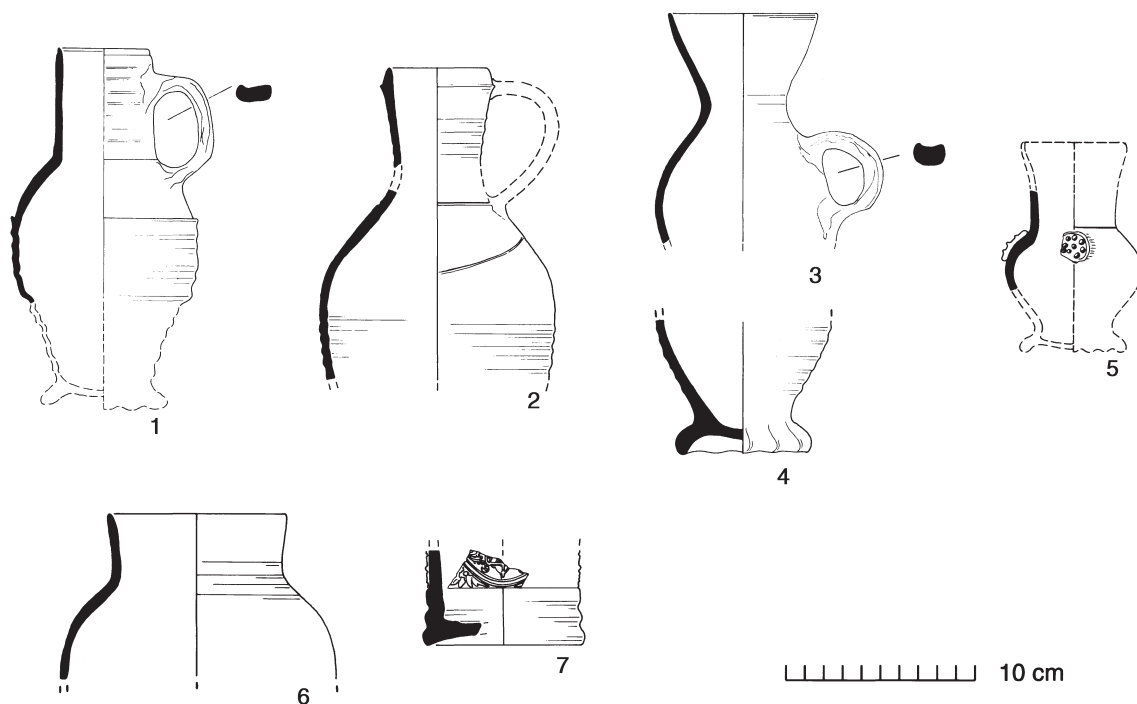

Fig 187 Siegburg stoneware: jugs (nos 1-6); mug or schnelle (no 7). 1:4.

lacking its top, was found in Serpentine Walk (Colchester) some years ago. This has an elaborate circular roundel containing an inner lozenge and, within this, a profile of a woman in flowing dress holding a communion chalice containing the Host in her right hand, and in her left hand a tall staff bearing a crucifix which rests against her shoulder. A ribbon arching over the figure contains the inscription 'DER. GE LV' (CM 185.1964). This appears to be identical to an example from London (Gaimster 1987, fig 1.6), and a very similar roundel occurs on a *Pulle* dated 1566 which is illustrated in Reineking von Bock (1971, no 179).

#### Green-glazed Siegburg

Perhaps the rarest and most interesting Siegburg items are two small body sherds, apparently from the same vessel, covered externally with a bright green glaze (LWC AF6 & LWC A1, not illustrated). These were residual in 18th-century and topsoil contexts. Green-glazed Siegburg is a characteristic 15th-century type found in small quantities throughout north-west Europe but relatively uncommon in Britain (Hurst *et al* 1986, 129). The glaze is a lead rather than the normal ash or salt glaze found on stonewares, and it required the re-firing of the vessel at lower temperatures. Green glazing of this sort was carried out by the earthenware potters of the Low Countries where green-glazed Siegburg has been found on several kiln-sites, whereas in Germany itself the practice was unknown at this time.

#### Langerwehe stoneware (Fabric 45A)

[Fig 188]

Weight: 7.815 kg

Number of sherds: 215\*

EVEs: 4.73\*

Langerwehe lies in Germany, on the River Eifel between Aachen and Cologne. Production of true stonewares here began *c* 1324 and continued right up to the early 20th century (Hurst *et al* 1986, 184). The great bulk of Langerwehe stoneware from British sites, however, was imported between the late 14th and the late 15th centuries. The industry declined at the end of the 15th century and, beyond this, Langerwehe products in Britain are represented only by large storage vessels (Gaimster 1987, 347), as opposed to the earlier jugs, costrels and cups.

As is usual for British sites, sherds of Langerwehe from Colchester out-number those of Siegburg stoneware, in this case by between two and a half to three times the amount. A single sherd of Langerwehe occurs in Period 3.2 where it comprised a mere 0.01% (by weight) of the assemblage. At its peak in Period 4.2, the fabric comprised 8% (by EVEs) of the assemblage (or 2% by weight). Thereafter its presence was very minor.

Langerwehe has a dark grey, somewhat underfired fabric. It is often covered externally with a dark purplish-brown iron wash giving a matt texture. Salt glazing is common,

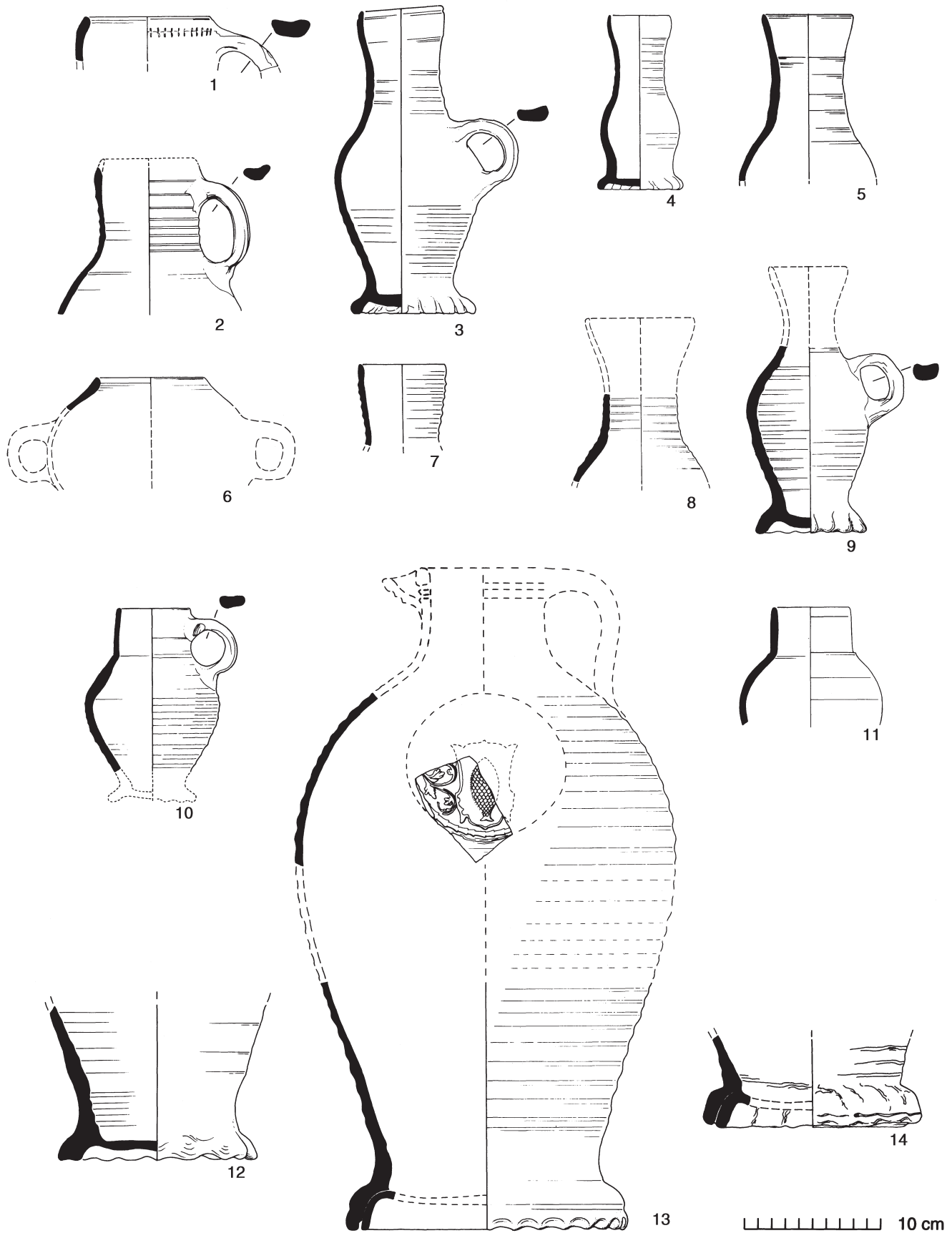

Fig 188 Langerwehe stoneware: jugs (nos 1-5); cup (no 6); jugs (nos 7-11; nos 8-9 with filed-down rims); storage jugs or Vorratskannen (nos 12-14). 1:4.

producing a glossy grey finish with brownish iron-rich patches. Poor kiln control, however, often resulted in a wide variety of fabric colour and surface textures. This is very marked among the Colchester material where buff and cream-coloured fabrics are very common, normally on the most underfired, poorly fused fabrics. It can be very difficult to distinguish better-fired late 15th-century Langerwehe vessels from the contemporary products produced at nearby Raeren. Not only were fabric and finish similar at this date, but several Langerwehe and Raeren forms were identical, in particular the tall, plain-rimmed *Jacobakanne* (Fig 188.3), the smaller cylindrical-necked mug (Fig 188.10-11), and the small two-handled cup (Fig 188.6). The policy adopted towards this problem in Colchester was to identify only those iron-washed and/or poorly fused, generally dull grey fabrics as Langerwehe, and the glossy, salt-glazed, well-fired dark grey fabric (with small purplish-black inclusions) as Raeren stoneware. Some margin of error, however, is inevitable, particularly for the forms mentioned above.

Iron-washed Langerwehe jug sherds occur in the town wall context of c 1382-1421 (Stratified Group 9, Fig 220.5-6). It occurs throughout the 15th century almost exclusively as types of jug and *Jacobakanne* (Figs 188.1-5 & 188.7-9), and still occurs in many late 15th- and early 16th-century pits as plain-rimmed *Jacobakannen* and small cylindrical-necked mugs (Fig 188.10-11), alongside their equivalent Raeren stoneware forms (eg Stratified Groups 13 & 14). The latest form to occur (in early 17th-century contexts) is the very large storage jug (Fig 188.12-14).

Except for two bevelled rim jugs, including the only example with rouletting (Fig 188.1-2), all other jug rims present are plain, though usually slightly flared. The beaker Figure 188.4 is strikingly similar to Siegburg forms (Hurst *et al* 1986, pl 30, centre) and comes from a late 15th- or early 16th-century context with Raeren mugs. Despite the commonness of stoneware in Colchester, it is evident that stoneware vessels were valued and conserved more than local wares. Several examples exist where vessels with broken rims have been made serviceable again by filing down the break to a new secondary rim (Fig 188.8-9, with pottery consistent with a date of c 1450-75). Conservation also probably accounts for the continuing frequency in early 16th-century contexts of *Jacobakannen* which one would otherwise be inclined to date to the late 15th century (Fig 188.3, Stratified Group 13, c 1500-1525; Fig 188.5, Stratified Group 14, c 1525). With later, more decorated Cologne and Frechen stonewares, this conservation factor is even more marked. The base of one Langerwehe *Jacobakanne* (not illustrated) had an iron wire hoop wrapped around the constriction above its frilled base, perhaps intended for carrying the vessel around like a costrel attached to a waistband (LWC LF101, Period 4.1).

Underfired, iron-washed mugs (Fig 188.10-11), the fore-runners of the ubiquitous Raeren mug, are found in an early/mid 15th-century context (Fig 188.7, Stratified Group 10), but are commoner in later contexts. The latest Langerwehe products represented in Colchester are several very large storage jugs or *Vorratskannen* (Fig 188.12-14). Identical vessels were made at Raeren during the same period and in a visually identical fabric. Both Langerwehe and Raeren types are here treated together.

The best-preserved *Vorratskann* (Fig 188.13; reconstruction based on Reineking von Bock 1971, no 336) comes from a mid 17th-century apothecary's dump (Stratified

Group 20), along with a great deal of later 16th-century pottery including a Frechen *Bartmannkrug* bearing the date 1594 (cf Fig 194.14). The applied medallion on Figure 188.13 bears the arms of Anthony de Both who was probably a Dutch merchant. The fish symbol is a play on de Both's own surname which means 'flounder' (*Both/Butt*). Two identical jugs with the same crest and with finely modelled *Bartmann* masks are known from collections in Germany: one is dated 1592(?) (Klinge 1979, no 26), the other 1595 (Sielmann 1980, fig 5). Similar large storage jugs may be seen in the apothecary of Klosters Museum, Bruges. Recent research at Langerwehe suggests that the de Both jugs were products of the Raeren kilns rather than those of Langerwehe (Dr B Sielmann, pers comm, 1988). An unusual feature displayed by these vessels is the floor of the base which, in some cases, appears to have been added separately.

A complete *Vorratskann* in Colchester Museum (unaccessioned) has a large squared *Bartmann* mask and three applied medallions bearing a coat of arms (three post horns), a monogram and the inscription 'ANNO 1604 ANIEAS WALENS' (the final 'S' being reversed). Bands of wavy combing occur on the shoulder/neck area of this jug and similar combed sherds have turned up on the excavations (not illustrated). The strap handle is lightly thumbled along the external margins. The closest parallels for this medallion are to be found among material from Raeren (B Sielmann, pers comm). Figure 188.12, with its underfired cream fabric and oily brown iron wash, resembles the 15th-century fabrics but was found unstratified along with large amounts of 17th-century pottery and is, therefore, more likely to be of this date.

### Gothic (Saxony) stoneware (Fabric 45K)

[Fig 189]

Weight: 0.005 kg

Number of sherds: 2

'*Gotisches Steinzeug*' is one of the names given to the most elaborate type of stoneware produced in medieval Germany. The collective term 'Falke group' named after Otto von Falke who made an early study of this ware, continues to be used for convenience, although his suggestion that it was produced at Dreihausen in Hesse is now no longer credited. In his overview of the ware, Gaimster refers to it as 'Saxon medieval stoneware' (Gaimster 1997), since the focus of its distribution clearly lies in Saxony/Thuringia in which area Gothic stoneware was almost certainly made. Waldenburg, near Leipzig in Saxony, was producing fully-fused stoneware by the early 15th century, and is one of the most likely places where Gothic stoneware was manufactured (*ibid*; and Hans-Georg Stephan, pers comm). The combined archaeological evidence from European find-spots suggests a relatively short-lived period of production between the beginning and the final quarter of the 15th century (*ibid*).

Only some dozens of complete Gothic stoneware vessels have survived in European museum collections though rather more fragments are now being recognised from excavations. The Colchester example is, so far, the only example known from a British site.

Vessel forms comprise highly decorated drinking vessels, mainly beakers and elaborate goblets or chalices, with stamped and applied decoration, the most elaborate of which clearly imitate contemporary gold-plate forms of the 15th century. Their luxury character is emphasised by the presence on some examples of polychrome enamel painting or applied gold leaf. Some surviving examples have silver or silver-gilt mounts (*ibid*; Stephan 1983, pl 8.VIII, nos 3 & 4; Charleston 1976, fig 372). Outside Germany, Gothic stoneware has been found in Hungary, the Czech Republic, Austria, Poland and southern Scandinavia (where there are several examples), and there are single examples at Bruges (Belgium) and even as far away as Iceland.

The Colchester piece (Fig 189.1) has a uniform hard grey stoneware fabric, not dissimilar to Raeren, but with a faint sandwich effect giving a pale purplish-grey colour at the margins and a pale brownish-grey core. The external surface is covered with a uniform dark purplish-brown iron slip under a lustrous clear salt glaze. The inner surface is an unglazed brownish-grey colour with regular indents caused by the external stamping. It is likely that the sherd comes from the upper part of a tall biconic drinking goblet (David Gaimster, pers comm) with the neck/shoulder junction separated by a cable-twist cordon. The stamped or rouletted bands of alternate open and closed squares form a densely spaced chequer pattern over the entire body surface which is typical of Gothic stoneware. Originally, the Colchester vessel may have resembled the biconic goblet illustrated by Stephan, which has a chalice-like lobed pedestal base, an anthropomorphic mask on the front and an anthropomorphic knobbed lid (Stephan 1983, pl 8.VIII, no 4).

The sherd, which shows very little sign of wear, was found in a soil and rubble layer (LWC G110) on the north side of the south yard of one of Colchester's few medieval stone houses, which stood on the west corner of Lion Walk and Culver Street (Building 28, see p 5 & Fig 158). This area of the yard was converted into a room in the 17th century. (The sherd came from the area immediately west of the 17th-century chimney stack GF55; CAR 3, fig 67.) Revised ceramic and stratigraphic dating for this site places the layer in LWC G Period 3 (c 1500-1600), though it could have begun earlier than this. From the same layer came a small sherd of Colchester sgraffito ware and four sherds of Colchester ware which are not incompatible with a 15th-century date, providing they are not residual. The layer was sealed by a mortar floor, and the second layer deposited on this contained a distinctive late 15th- or early 16th-century Colchester ware intumed-rim jar.

Unfortunately nothing is known of the early history of the stone house where the sherd was found. In the late 15th and early 16th centuries, however, it may well have formed part of the Colchester estate of the Dukes of Norfolk/Earls of Surrey who owned much of the property in the Lion Walk area, though the house could have been let to a tenant. Finds of Gothic stoneware on the Continent have normally been associated with high-status sites such as royal palaces, castles, monasteries and merchant town houses. The fact that the house at Lion Walk was of stone (rather than the town's usual timber-framed constructions) implies that its owners were fairly prosperous, and the pottery sequence from the site supports this notion. It is not unlikely therefore that Building 28 could have been the house of a wealthy, possibly foreign, Colchester merchant.

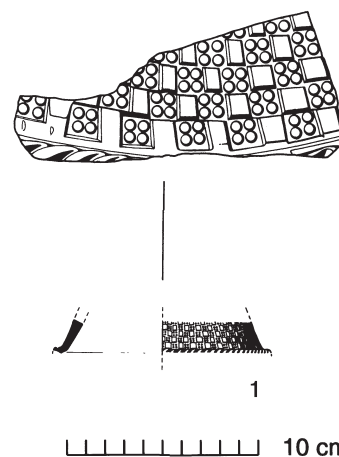

Fig 189 'Gothic' (Saxony) stoneware (Gotisches Steinzeug): drinking vessel (no 1). 1:4 with detail at 1:1.

Unlike the Rhenish stonewares from Colchester, the Gothic stoneware vessel is unlikely to have reached England via the traditional Rhine/Low Countries trade route which lay too far west of its central or east German production area. It is rather more likely that it was traded down the River Elbe (via Hamburg) to the North Sea or, in view of the increasing number of Scandinavian finds, down the River Oder and then via the Baltic sea route to England. Perhaps, then, this vessel is the only tangible evidence of Colchester's direct maritime trade links with the Baltic in the 14th/15th centuries (see historical background, p 18).

#### Raeren stoneware (Fabric 45C)

[Figs 190-1]  
Weight: 27.460 kg  
Number of sherds: 719\*  
EVEs: 22.76\*

Raeren is situated just inside the Belgian border to the south-west of Aachen and Langerwehe. Stoneware was produced here at least from the mid 15th century and continued well into the 17th century, although the great bulk of it imported into Britain arrived in the late 15th and early 16th centuries (Hurst *et al* 1986, 194). Raeren stoneware has a fine, well-fired, dark grey fabric with sparse purplish-black specks and an external covering of glossy salt glaze, generally pale grey with browner patches. The late 15th-century products, particularly if poorly fired, may be impossible to distinguish from Langerwehe products. Similarly it is not possible, in isolation, to distinguish between Raeren stoneware and the contemporary late 15th-/early 16th-century products of the Aachen kilns (*ibid*, 190-93).

Although rather less Raeren than Cologne/Frechen stoneware was excavated, Raeren was nevertheless more widely used in late 15th-/early 16th-century Colchester than any other type of stoneware at any other time in the town's

history. In Period 4.2, Raeren alone accounted for nearly 21% of all pottery used in the town (or 7% by weight, Fig 190), or perhaps one should say that between them Raeren/Langerwehe products accounted for 28% of all pottery in use at this time (or 9% by weight).

Tall, funnel-necked *Jacobakannen* (Fig 191.1) are relatively common in early 16th-century contexts at Colchester, although some of these could easily be Langerwehe products. By far the commonest form, however, is the ubiquitous Raeren drinking mug (Fig 191.2-11) which was imported into Britain in great numbers between c 1475 and 1550. Many of the Colchester examples were clearly 'seconds' which display considerable warping (Fig 191.5), flawed rims, kiln scars and chipped bases which were subsequently glazed. The most surprising evidence of this nature is a small fragment of the internal wall of a vessel (LWC G72) which must have spalled off before firing and then fallen into some part of the kiln where it became completely covered in salt glaze. This, perhaps, made its way to England inside another vessel. Horizontal bands of rouletted decoration occur on a small number of mugs (Fig 191.9-11). At least three mugs have crudely applied and incised human faces (Fig 191.12, Stratified Group 14, c 1525; Fig 228.10-11, both Stratified Group 15, c 1525-50). Figure 228.10 has, in addition, faint bands of horizontal rouletting and a hexafoil rosette stamp to one side of the face. Figure 228.11 has an underfired reddish fabric which might, ordinarily, have been called Langerwehe stoneware. A flat base (Fig 191.14), from the same context, might also have come from a face mug. Costrels or jugs with narrow Aachen-type necks and collared or cordoned rims are represented by under half-a-dozen examples. Some of these (Fig 191.13) have traces of incised decoration indicating an original decoration of an applied face (Hurst *et al* 1986, pl XI). Globular

two-handed cups (Fig 191.15) occur in both Raeren and Langerwehe stoneware and are represented by only one or two examples. The small pedestal-based cup or *Tasse* (Fig 191.16) is the only example of its form and is dated by parallels to the second half of the 16th century (Reineking von Bock 1971, no 375).

Another unusual form (only represented on the 1986-7 Angel Yard site) is a small flat-based oil pot (as Hurst *et al* 1986, fig 94.308). Three Raeren stoneware spindlewhorls were also found on the excavations (*CAR 5*, fig 35.1934-6). Two of these are of globular type (type I) and one is of conical type (type II; cf Hurst *et al* 1986, fig 100.318-20 & 321 respectively). The conical example came from Stratified Group 18 (c 1625-50). Some of the latest Raeren products represented are several fragmentary, highly decorated panel jugs and possibly biconic jugs covered in an even brown glaze (Fig 191.17-20). Panel jugs were created in 1576 by the master Raeren potter Jan Emens and are characteristic of the last quarter of the 16th century. Dated examples are known from several collections, those of the 1590s apparently being the most common, although some are dated as late as 1609 (Hurst *et al* 1986, 201-6). Figure 191.17 (Stratified Group 18, c 1625-50), with its 'cut-glass' shoulder decoration, is doubly interesting on account of the remains of a pewter lid-hinge still attached to the handle. Originally, many such vessels would have been embellished with pewter or silver mounts, but these were normally removed before the vessel was discarded. Classical busts, such as the Mercury in Figure 191.19 and the flanking arabesques on both this and Figure 191.20 (Stratified Group 21, c 1680-1700) are typical of the highly decorated Raeren style. These late 16th-century Raeren products are represented by a minimum of between thirteen to fifteen vessels, whereas the earlier 16th-century plain mugs could represent several hundred vessels. Another late 16th-/early 17th-century Raeren form is the large storage jug or *Vorratskann* which also occurs in Langerwehe and has been discussed under that section (see p 280).

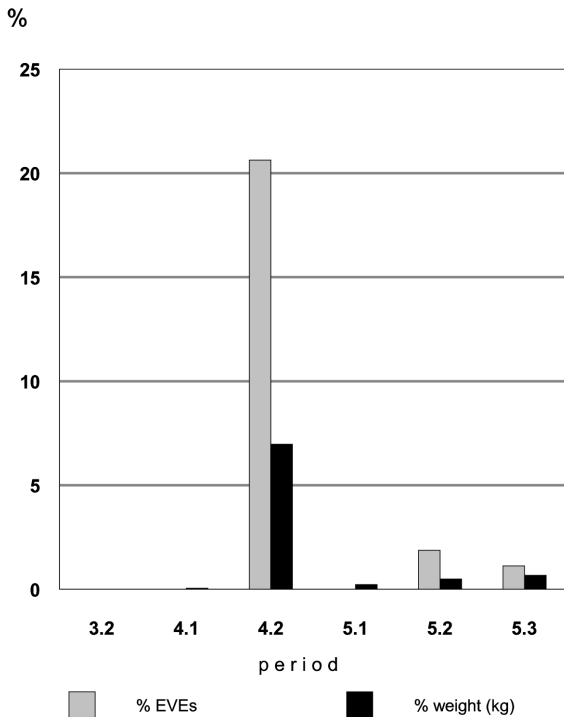

Fig 190 Raeren stoneware: percentages in stratified contexts (ceramic periods).

### Cologne and Frechen stonewares

(Fabrics 45E & 45D)  
 [Figs 192-5]  
 Weight: 33.415 kg  
 Number of sherds: 957\*  
 EVEs: 30.61\*

Cologne and Frechen, both in Germany, lie only 10 km apart. Both were major centres of stoneware production and their products were very widely traded. There was a good deal of ebb and flow between the potters of Cologne and Frechen during the 16th century. Early in the century, potters from Frechen moved to Cologne, but in the middle of the century they were forced to return to Frechen, apparently due to the pollution problem posed by their kilns in the city centre (Hurst *et al* 1986, 208). Thereafter, Frechen products gradually superseded those of Cologne which were never traded in anything like the abundance that Frechen was traded in the later 16th and the 17th centuries.



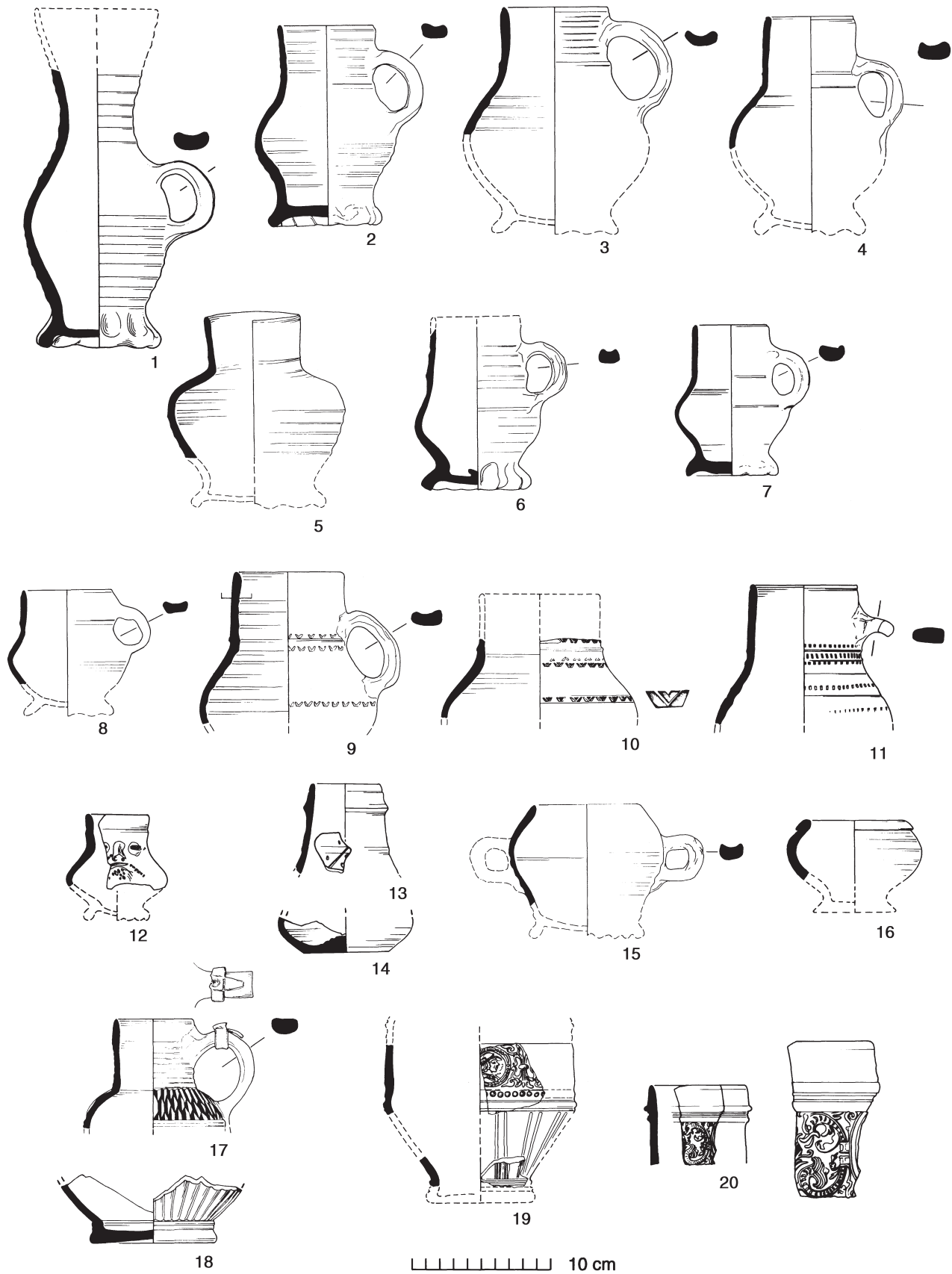

Fig 191 Raeren stoneware: jug (no 1); drinking jugs or mugs (nos 2-11); face jug or mug (no 12); costrel or jug (no 13); flat ?jug base (no 14); cup (no 15); pedestal cup or tasse (no 16); Renaissance panel jugs (nos 17-20; no 17 with remains of pewter lid-hinge). 1:4; no 20 decoration detail at 1:2.

The proximity of both centres and the movement of the potters and their moulds makes it almost impossible to distinguish between certain of their products. For this reason both types are here considered together. Excavations at the kiln-sites, although showing that identical wares were often made at either site during the early to mid 16th century, do however indicate that certain types of form and decoration are more typical of one site rather than the other and these attributions will be given here where possible.

Cologne/Frechen stonewares first appear in Period 4.2 where they comprise 2% (by EVEs) of the assemblage (or 0.8% by weight). They have an exaggerated presence in Period 5.1 due to the small sample size, but their true peak is reflected in Period 5.2 (1600-1675/1700) where they almost comprised 9% (by EVEs) of the assemblage (or 5% by weight; Fig 192).

Typical Cologne products have a fine dark grey fabric indistinguishable from Raeren but with an even brown salt glaze. Frechen tends to have a slightly coarser dark grey fabric with a distinctive mottled brown 'tiger' salt glaze, particularly on the later wares. Some of the Cologne/Frechen items from Colchester have a buff or cream fabric, possibly due to underfiring (eg the inscription-band jug Figure 235.18).

Cologne-type globular mugs with a sprigged oak-leaf and acorn scroll (Fig 193.1), or with a rose and leaf scroll decoration (not illustrated), are typical of the first half of the 16th century (Hurst *et al* 1986, fig 101.326-7). At least seven such vessels were recovered, four of them being the oak-leaf type. Even rarer are the small cylindrical tankards or *Pinten* of which Figure 193.2 is a particularly fine example. The three panels of applied moulded decoration depict, from right to left, the Biblical narrative of God creating Adam from the clay, the temptation of Adam and Eve, and the flight from the Garden of Eden. The vessel is covered externally with an even brown salt glaze. The handle is missing. This decorative theme (*Sundenfall*) was popular on Cologne tankards of the second quarter of the 16th century (cf Reineking von Bock 1971, nos 301-4), and this example could well be contemporary in its pit context which contained only local coarsewares of the first half of the 16th century. A second tankard base, with a more mottled salt glaze, came from Stratified Group 18 (c 1625-50).

Globular-bodied Frechen jugs with tall cylindrical necks and moulded pad bases (Fig 193.3-7) replaced the frilled based Raeren jugs c 1550 as the commonest imported stoneware form in Britain (Hurst *et al* 1986, 214, 216). These are easily the commonest stoneware form in Colchester and remain common in mid 17th-century groups (eg the developed form Fig 193.3; Stratified Group 19, c 1650).

Girth-band jugs with a bearded *Bartmann* mask and applied portrait medallions (Fig 193.8-9) were produced at both Cologne and Frechen and are typical of the second and third quarters of the 16th century. At least eight examples were found representing all three types of girth-band *Bartmann*: one example of the foliage-band type with a squared mask (fragment as Hurst *et al* 1986, pl 38), one example of the geometric-band type (Fig 193.9 & *ibid*, fig 104.330; c 1525-75), and six inscribed-band types (Fig 193.8). Three girth-band *Bartmann* jugs and several other high-quality stoneware vessels came from an unusually rich apothecary's dump (Stratified Group 20, c 1650; see p 337). All the inscriptions repeat themselves three times around the vessel, the commonest being 'DRINC VND ES GOT

NIT VERGS' (Fig 193.8), also as 'DRINC:VN: ES GOT:NIT:VER:' (Fig 235.18, Stratified Group 20); 'WIL:SO:IST: MEIN:ZILT:' (Fig 236.27, Stratified Group 20); and one fragmentary example '(HEREN:WART: BLEIFT:IN EKEI(T:)' (Fig 195.30). In contrast, this last inscription is the commonest found in Chelmsford (Cunningham 1985, 66). As with the earlier Raeren mugs, it is evident that many Cologne/Frechen vessels in Colchester were kiln 'seconds'. Figure 235.18 is underfired, dented and spalled in places, and Figure 236.27 is badly dented and scarred on one side where an adjacent vessel in the kiln became fused to its surface and had to be chipped off.

Also from Stratified Group 20 was a fine mid 16th-century double-loop handled jug, Figure 193.13 (cf Reineking von Bock 1971, nos 273 & 287). This has a decoration of applied raspberry stamps on the body and an arabesque frieze on the neck, possibly representing mermaids with intertwined tails. The raspberry stamps appear to be quite worn through age, which is only to be expected considering that many of the stoneware vessels in this group were between 50 to 100 years old when they were discarded. This is the usual trend in Colchester, where the finest stoneware vessels were kept for a long period of time and vessels of the early, mid and late 16th century inevitably end up in contexts with clay pipes, coins and other finds datable to the 17th century or later.

The largest class of vessel recovered is represented by a tall, globular Frechen *Bartmann* jug (Fig 194.14; Stratified Group 20). This had three large roundel medallions, the two at the sides being identical and different from the one below the mask. All three bear the Tudor royal arms and the date 1594. Those at the side bear the inscription 'ELISABEHT. DEI. GRACIA. REG(/NA)', the mis-spelling of Elizabeth being due to the German craftsman's unfamiliarity with the English spelling. On the front medallion a simple 'ER' monogram was sufficient. The outside of the vessel is

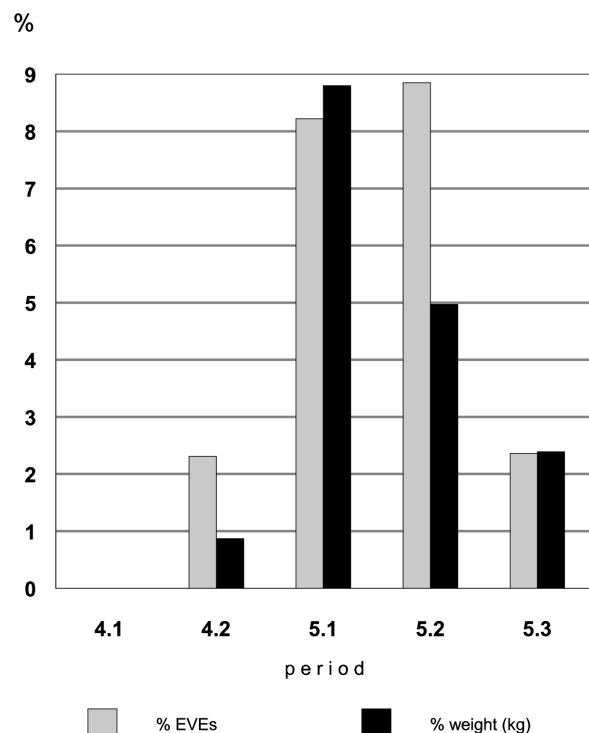

Fig 192 Cologne and Frechen stonewares (Fabrics 45D & 45E): percentages in stratified contexts (ceramic periods).

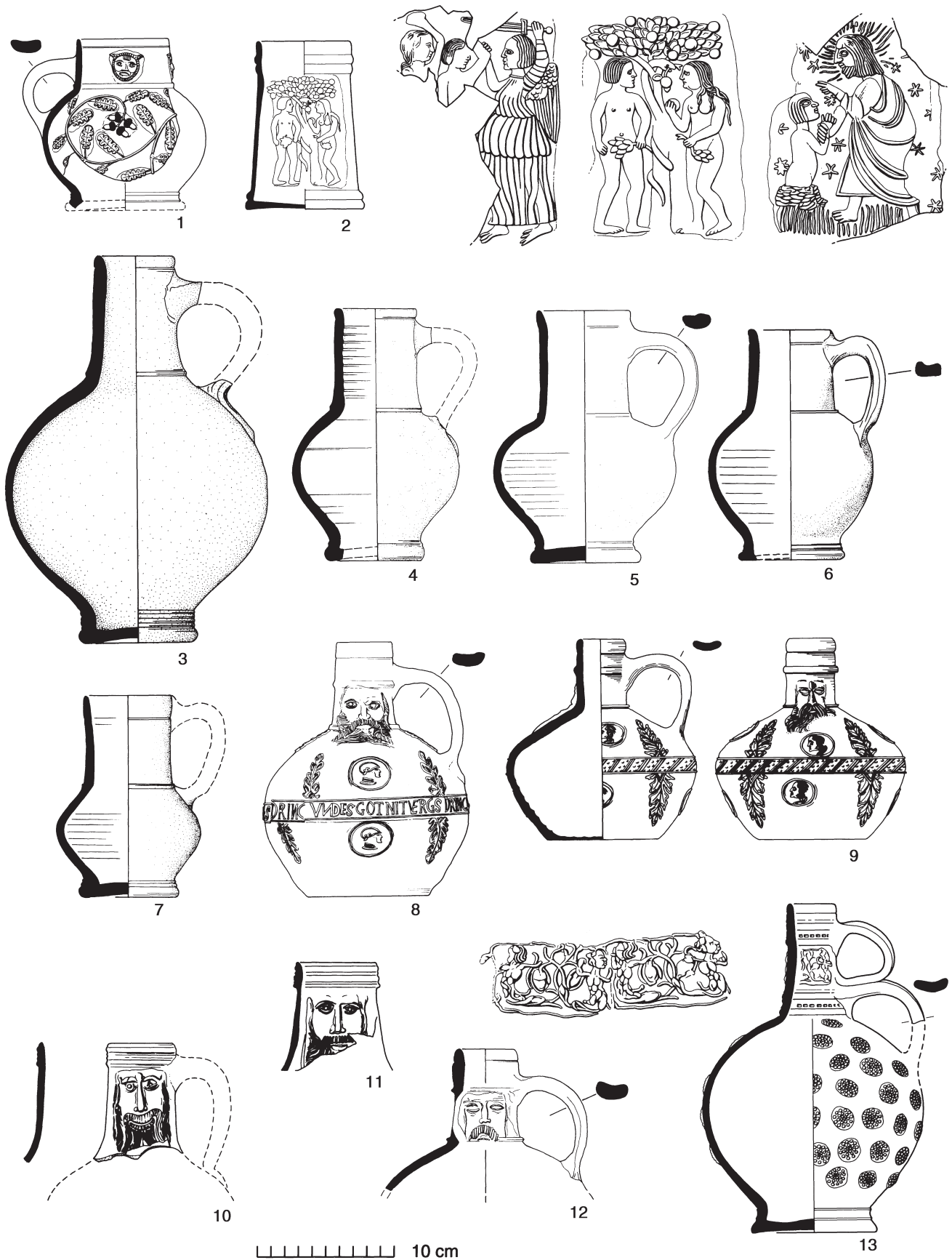

Fig 193 Cologne and Frechen stonewares: globular mug with oak-leaf scroll and imp mask decoration (no 1); tankard or pinte with biblical decoration (no 2); globular jugs (nos 3-7); girth-band Bartmann jugs (nos 8-9); other Bartmann jugs (nos 10-12); double loop-handled jug (no 13). 1-4, except no 2 and no 13 decoration details at 1:2.

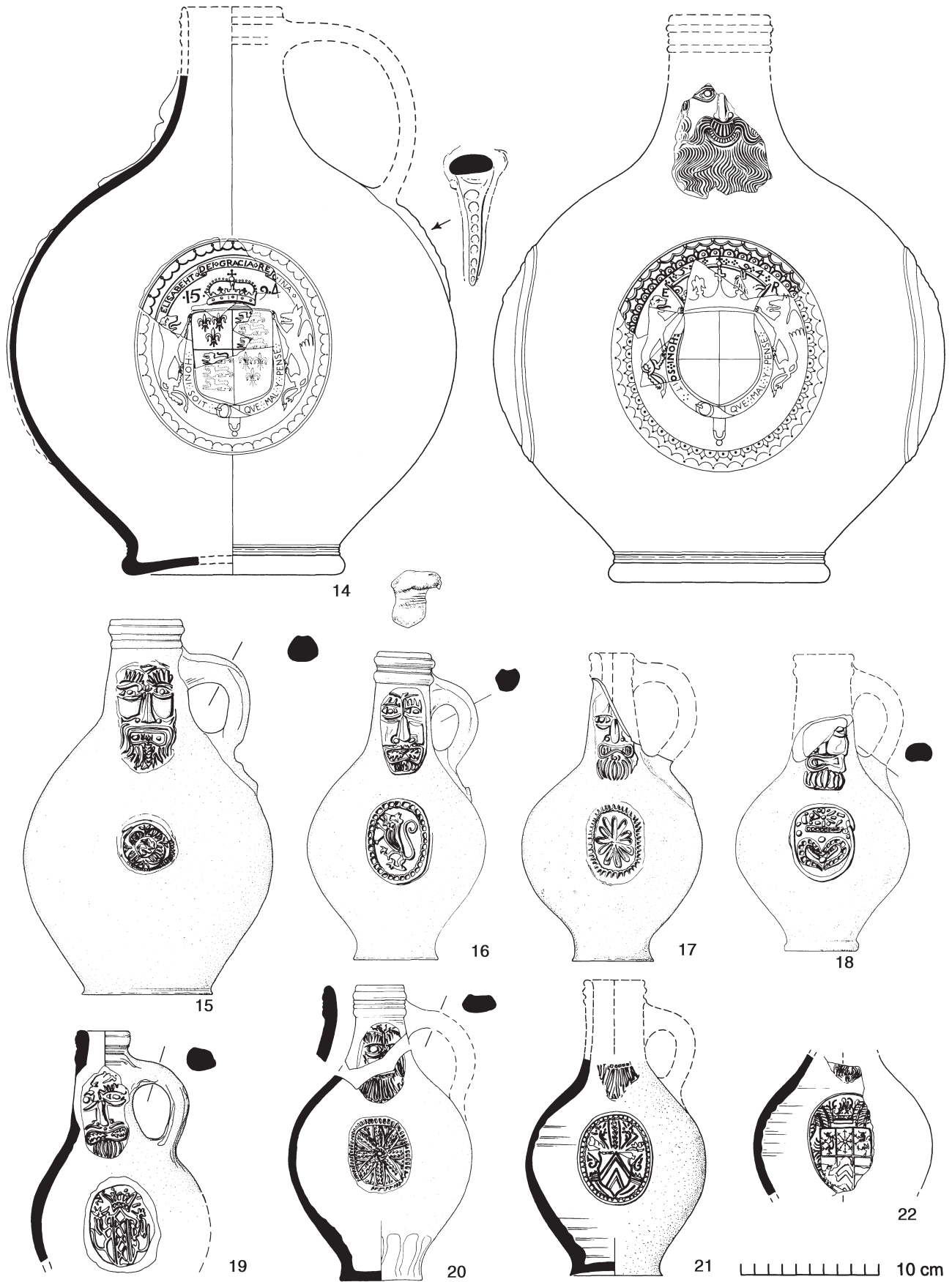

Fig 194 Cologne and Frechen stonewares: Bartmann jugs (no 14 with Tudor royal arms and date 1594; no 16 with rag stopper) — for convenience, handles on nos 15-21 shown at right-angles to mask. 1:4.

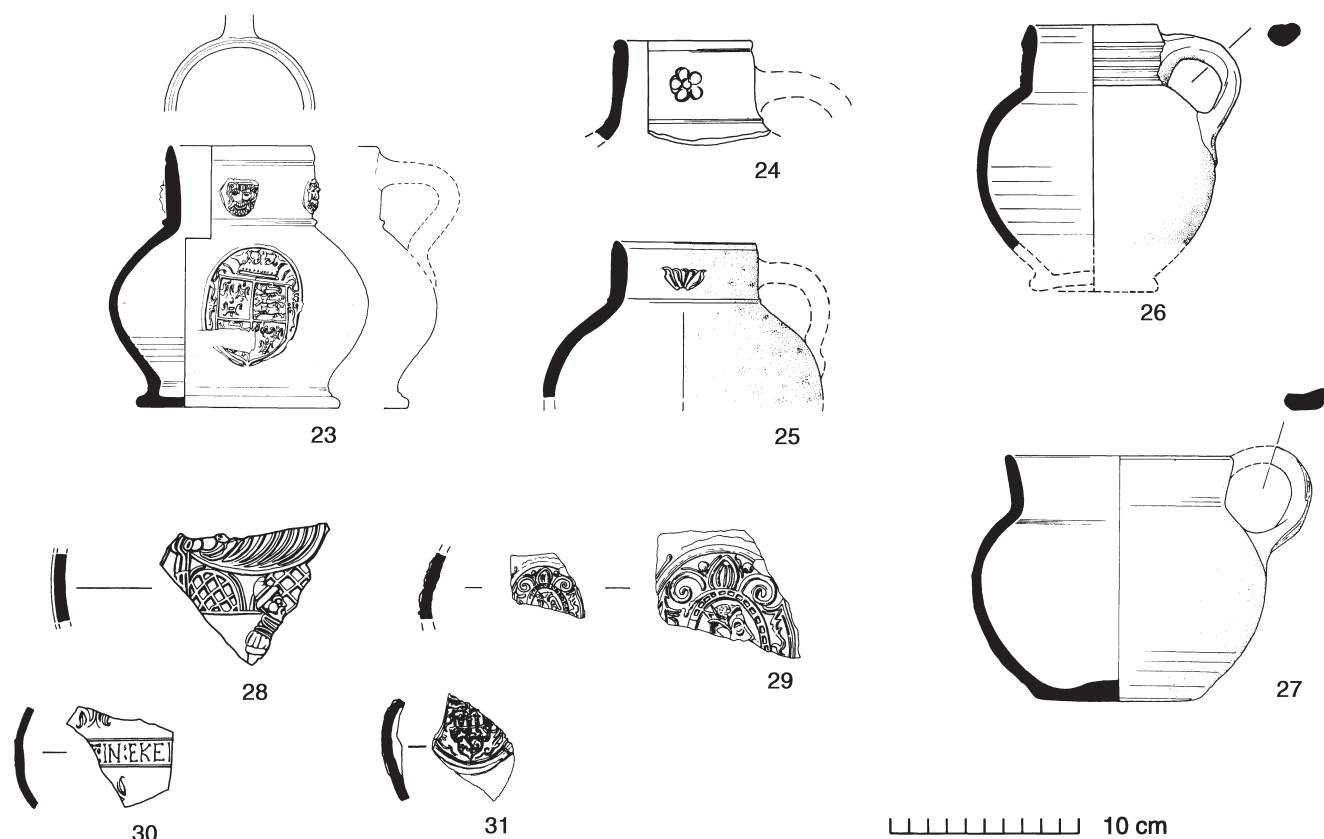

Fig 195 Cologne and Frechen stonewares: globular mugs (nos 23-26; no 23 with royal arms); chamberpot (no 27); decorated jug fragments (nos 28-31). 1:4 except nos 28-29 details at 1:2.

covered with a mottled brown 'tiger' glaze with vertical flow lines and which ends 6 cm above the base. The interior is covered a clear or pale grey glaze. Highlights of blue cobalt paint occur externally on the eyebrow and moustache of the finely moulded mask and on the crowns and heraldic supporters in the medallions. The inner scalloped border zone of the front medallion is all in blue but, on the side medallions, blue highlights occur only at intervals along the border. *Bartmann* jugs with the date 1594 are known from several other locations in Britain and elsewhere (Gaimster 1987, fig 5.6), and include a smaller example in Colchester Museum. The significance of the date 1594, however, is unknown. Sherds from two other vessels with blue painted medallions came from the Middleborough site (MID 1620). The grinning *Bartmann* mask is of Holmes type III and is very similar to a *Bartmann* jug illustrated by Holmes dated 1590 (Holmes 1951, pl 22b).

Figure 195.23 (Stratified Group 20), probably Frechen, continues the shape and some decorative features, namely the imp-masks, of early 16th-century Cologne mugs. On the front, the Tudor royal arms have become rather stylised and debased, with the heraldic supporters becoming reduced to mere squiggles. All these features suggest a late 16th-century date. An identical applied coat of arms which had become detached from its vessel was found in Stratified Group 18 (c 1625-50). One or two more fragmentary Tudor arms medallions are known from other contexts, and there is another complete example as Figure 195.23 in

Colchester Museum. Similar vessels with a simpler decoration of rosette or shell stamps date from the 17th century (Fig 195.24-25). Both those illustrated were associated in contexts with clay pipes of c 1660-80.

Frechen *Bartmann* jugs of the mid and late 17th century have narrow tubular necks with double-cordoned rims and narrow ovoid bodies (Fig 194.15-22). Most of the Colchester examples have the debased grimacing mask of Holmes type VIII and simple heraldic medallions. It is for this type that the otherwise confusing name 'Bellarmine' should be reserved. Among the recognisable coats of arms are the crowned arms of Jülich, Mark, Kleve and Berg (Fig 194.22), the debased arms of Amsterdam (Fig 194.19), and the arms of the city of Cologne (Fig 195.31, early 17th century). The other devices have no particular heraldic significance. Figure 194.21 was associated with a coin of 1636-44 and clay pipes of 1640-80. Figure 194.18-19 came from a single pit context containing clay pipes of 1660-80. Figure 194.17 came from Stratified Group 21 (c 1680-1700). Figure 194.16 with its rag stopper came from a similar late 17th- or early 18th-century pit context and is complete. This might have been used as a 'witch bottle' but was found completely empty.

Other miscellaneous fragments include Figure 195.28, which comes from a late 16th-century Raeren-type panel jug (Hurst *et al* 1986, fig 98.315). The fabric, however, is Frechen. Figure 195.29, with its classical bust medallion, is also a 16th-century type.

Rare forms include chamberpots (Fig 195.27; Stratified Group 17, c 1625-50), represented by no more than two examples. The illustrated example is quite worn under the base and could have been old at deposition. There is the usual white deposit of uric compounds inside the vessel.

### Westerwald stoneware (Fabric 45F)

[Fig 196]

Weight: 11.815 kg

Number of sherds: 322\*

EVEs: 10.52\*

The Westerwald is an area lying close to Koblenz on the east bank of the Rhine in Germany. In the 1590s potters from Raeren moved to this area and established a major pottery industry which flourishes even today (Hurst *et al* 1986, 221-5). The fabric is fine and pale grey, like Siegburg, but the prolific blue painting, salt glaze and distinctive forms of Westerwald make confusion between the two very unlikely. In the early 17th century, blue painted jugs were made in the style of highly decorated Raeren jugs. Recent excavations, however, have shown that indistinguishable blue painted Westerwald-type jugs were also made at Raeren in the 17th and 18th centuries (*ibid*, 223; see below for possible example). Furthermore, Westerwald-type jugs were also made at the late 17th-century London potteries at Woolwich and Fulham (Pryor & Blockley 1978, 52; Askey 1981, 18, 185). It is probable, however, that the great bulk of Westerwald stoneware on British sites is from the Westerwald proper.

By the middle of the 17th century a greater diversity of vessel shapes and less formal decoration had appeared, and from 1665 purple was added to the colour scheme. Common late 17th- and 18th-century products included chamberpots with applied and incised decoration and mugs with combed scroll decoration and raspberry stamps. All these types were very widely traded.

A minimum of 76 identifiable vessels came from the excavations, falling into four main categories: jugs with slack profiles (4%), globular-bodied jugs with cylindrical necks and moulded pad bases (29%), chamberpots (30%), and cylindrical tankards (37%). Combining both jug types it can then be seen that jugs, chamberpots and tankards were reaching the town in roughly equal quantities.

Jugs with Renaissance-style decoration typical of the first quarter of the 17th century are represented by only two or three examples (Fig 196.1), including a sherd with 'cut-glass' decoration that may come from the shoulder of the illustrated example (Hurst *et al* 1986, pl 45). Another corduroy jug base has a multiple girth cordon with blue grooves and a raised ridge decorated with ovolos. The interior of this jug has a light brown glaze and the dark grey fabric is probably that of Raeren stoneware rather than Westerwald. This piece may therefore be an example of the Westerwald-type stoneware produced at Raeren (not illustrated; COC 1, unstratified).

Globular-bodied, cylindrical-necked jugs or *Kugelbauchkrugge* (Fig 196.2-6) are typical of the late 17th and early 18th centuries (Reineking von Bock 1971, nos 552-61), and one may be seen in Vermeer's painting 'Kitchen maid' of c 1660. In addition to the applied whorls and rosettes illustrated here, other sherds with applied vases of flowers and

lion masks were found (*ibid*, nos 519 & 556). Monogrammed jugs of William III (Fig 196.4) and King George ('GR') are known. Figure 196.5 has a portrait medallion of William and Mary above the following inscription in Dutch commemorating their visit to Holland in 1691: 'Thus bloom the orange and the rose in our Dutch Garden. 1691' (see Chaffers 1965, 310). This is plain, as is a smaller example in Colchester Museum, but other examples in the Victoria and Albert Museum have a purple reeded neck. The octagonal medallion of Figure 196.6 (Stratified Group 22) is virtually identical to an example illustrated in Reineking von Bock dated 1726 (1971, no 742). The raspberry stamps and flowers are highlighted in purple. Jugs with slack profiles and loosely executed blue painting (Fig 196.7) are characteristic of the later 18th century and following. Figure 196.7 and a similar example with a painted blue rosette around the handle base were both found in contexts with mid to late 18th-century wares including Staffordshire white stoneware and Queensware. Another came from a context of c 1840 (LWC VF1, see below).

Westerwald chamberpots (Fig 196.8) are very numerous. All have the usual applied lions of Nassau flanking a central roundel. One example came from Stratified Group 21 (c 1680-1700, Fig 241.22), and another from Stratified Group 22 (c 1730-40). Five Westerwald chamberpots were found in a brick latrine (LWC VF1) along with chamberpots in Fabric 40 and Pearlware, together with pottery and clay pipes suggesting a date range of c 1740-1840.

Tankards (Fig 196.9-15) are the most common Westerwald form present and those illustrated are typical of the late 17th and early 18th centuries. Figure 196.10 (Stratified Group 22) has a fragmentary octagonal medallion with a bust of Queen Mary (1689-95) with her Latin titles (Reineking von Bock 1971, no 578). Similar tankards with a bust of William III (*ibid*, no 537) have been found elsewhere in the town, as well as lozenge chequerboard tankards with the 'AR' monogram of Queen Anne. Figure 196.15 is the only barrel-shaped tankard found and should date to c 1700 (*ibid*, nos 610-13). It was presumably intrusive into an otherwise mid 17th-century context (Stratified Group 20).

Westerwald had a minor presence in Period 5.2, which rose to 2.3% (by EVEs) of the assemblage in Period 5.3 (or 1.7% by weight).

### 'Hessian' crucibles (Fabric 60)

[Fig 197]

Weight: 0.095 kg

Number of sherds: 1

EVEs: 1.00

A small complete triangular crucible (Fig 197.1) was found in Stratified Group 19 (LWC VF2), for which pottery and clay-pipe evidence suggest a date of c 1650. The fabric is a very hard, dark grey-brown, sandy near-stoneware. There is no evidence of burning, sooting or wear.

When excavated the crucible was half-filled with a hard rusty amorphous material (somewhat slumped to one side) into which a broken bowl rim of post-medieval redware



Fig 196 Westerwald stoneware: globular jugs (nos 1-6; no 5 with Dutch inscription and date 1691); slack-bodied jug (no 7); chamberpot (no 8); tankards (nos 9-15). 1:4, except medallions on nos 5-6 at 1:2, stamp on no 2 at 1:1 and stamp on no 15 at 1:2.

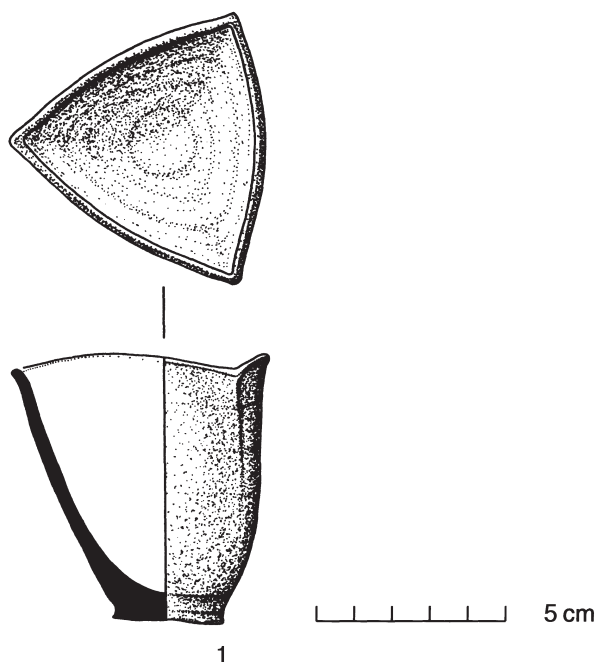

Fig 197 'Hessian' crucible (no 1). 1:2.

(Fabric 40) had become wedged, presumably after deposition. These contents limited investigation by X-ray fluorescence to the rim area where no non-ferrous metals were detected and, consequently, the function of the crucible could not be determined (CAR 5, 87, fig 96). During subsequent removal of the contents, numerous small droplets of liquid mercury were discovered trapped in voids scattered throughout the rusty material but principally towards the base of the deposit.

It is suggested elsewhere in this volume (see pp 232 & 334) that Stratified Group 19 and a number of other pit groups on Lion Walk represent material dumped from an apothecary's workshop. Quite probably the material was dumped on the death of Robert Buxton in 1655; he was a prosperous local apothecary who owned much of the frontage at Lion Walk. Besides the numerous tin-glazed drug jars from Stratified Group 19 and from other 'apothecary' groups nearby, the crucible found here is the only other ceramic that is strongly indicative of pharmaceutical (or alchemical) practices in the vicinity.

To explain the attribution to Hesse or even Germany requires a brief explanation of the historical background of crucible supply and production in Britain. Between the 16th and the 19th centuries, sandy near-stoneware 'Hessian' or triangular crucibles were almost entirely imported into Britain from Germany. Documentary sources make it clear that the main source for these was Hesse in the north-west of the country and that the main production centre was located at Grossalmerode (Cotter 1992). There are rare examples of English attempts to copy the form in the late 16th century (Pearce 1992, fig 46.456). There were also limited attempts to copy both the form and fabric of Hessian crucibles at Fulham, London in the late 17th century and in

Staffordshire a century later, but the English crucible industry did not enjoy widespread commercial success until the 19th century (Cotter 1992). It is highly probable, then, that triangular crucibles found in 16th- to 18th-century contexts in Britain will be of German origin, and if in a sandy fabric they can fairly safely be ascribed to Hesse, though only scientific analysis can verify this.

Hessian crucibles had a wide variety of industrial uses but were particularly associated with gold and silver metallurgy. There are numerous Dutch *genre* paintings, however, particularly from the mid to late 17th century, that depict the popular theme of 'the foolish alchemist' who is usually shown surrounded by glass alembics, retorts, and a miscellany of other vessels including (sometimes) triangular crucibles (eg 'The village alchemist' by Jan Steen, c 1668; *ibid*, pl 4).

Although Robert Buxton described himself as an apothecary, he was also a noted confectioner and a prominent figure in local government. At this period there seems to have been no very clear distinction between physician, apothecary and alchemist, and it may be that Robert Buxton dabbled in alchemy in between the main business of preparing medicines. It is unlikely that the true purpose of the mercury in the Lion Walk crucible will ever be fully understood. Mercury could be used in metallurgy (eg for gilding), but the context of the crucible strongly suggests a medicinal or alchemical preparation.

Elsewhere in the town a nest of five very similar triangular crucibles was found on the site of a chemist's shop in the High Street. The largest of these bears a heart-shaped stamp enclosing the letters 'CG' (*ibid*, fig 1), which is exactly paralleled at Great Yarmouth, Norfolk. What slender evidence there is suggests that the crucibles are 19th century and had been used as laboratory beakers.

### German slipwares (Fabric 44)

#### Weser slipware (Fabric 44A)

[Fig 198.1-5]  
Weight: 0.615 kg  
Number of sherds: 31  
EVEs: 1.25\*

A minimum of fourteen vessels in this ware was excavated. Weser has a finely sandy, hard, off-white to buff or pinkish fabric with a clear lead glaze over areas decorated with coloured slip. Only dishes and bowls were found (Fig 198.1-5). These normally have an internal covering of cream slip which provides a background for the simple but attractive designs in red-brown and green slip. Weser ware was produced at a number of sites in the *Pottland* between the river Weser and the Leine. Export of wares from these centres occurred mainly between 1580 and 1630, reaching a peak between 1590 and 1620. The main foreign destination was Holland though the wares are also common in Britain, particularly along the east coast. A few pieces even reached North America (Hurst *et al* 1986, 250-59).



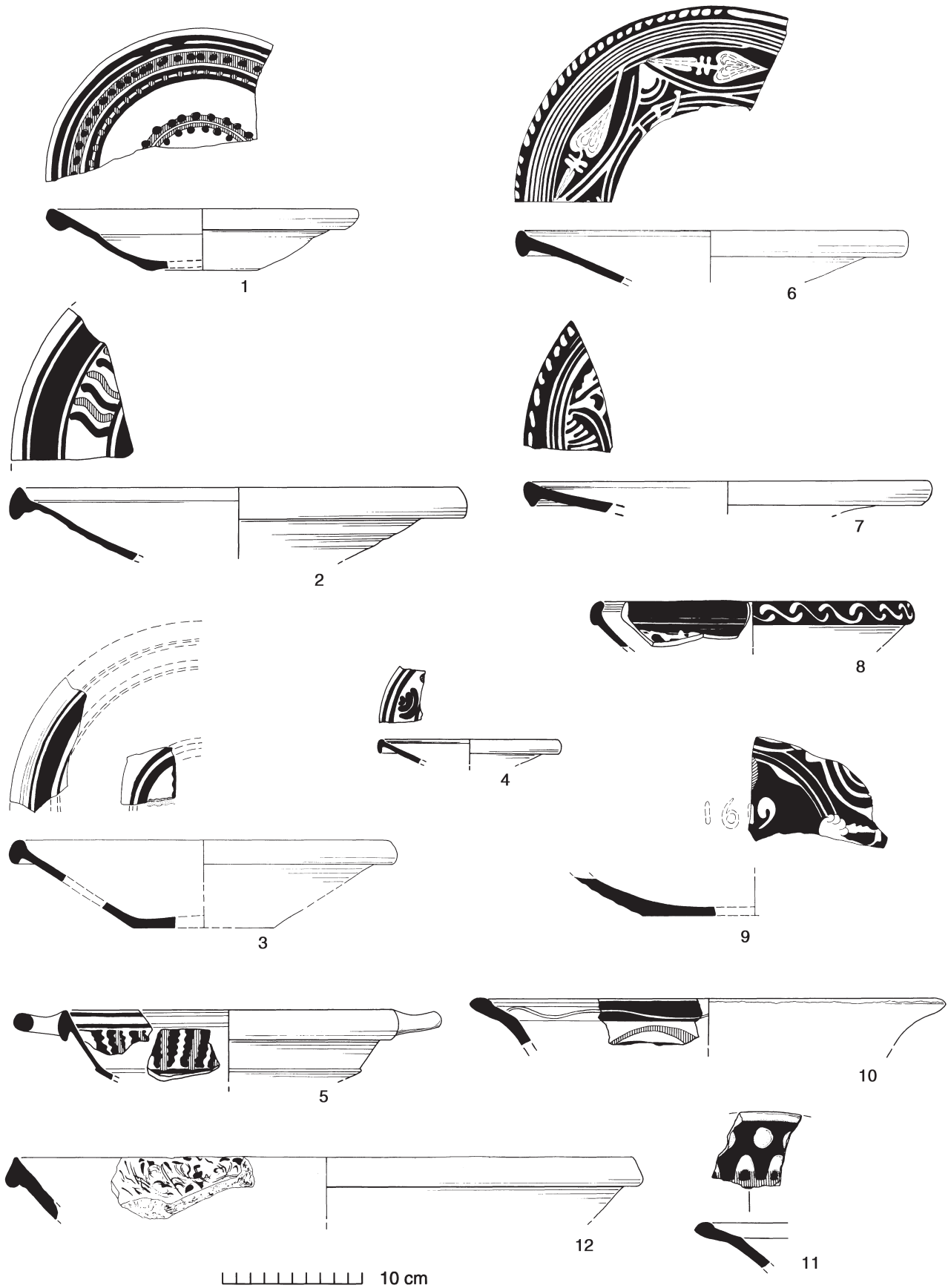

Fig 198 German slipwares: Weser slipware dishes (nos 1-5); Werra slipware dishes (nos 6-9); Lower Rhine slipware (nos 10-12). 1:4.

Figure 198.1 is probably the most unusual and attractive piece from the excavations. The interior is covered with a cream slip. At the edge of the rim and at the slight internal angle of the flange are pairs of red-brown concentric lines enclosing a central green band with red-brown blobs. The space between the inner pair of red-brown lines has green blobs while the centre of the dish has a pair of concentric green lines flanked by red-brown blobs. The unglazed exterior of the vessel is knife-trimmed towards the flat base which has crisp wire marks underside. This sort of heavily beaded, slightly flanged rim is generally uncommon on Weser dishes where hammer-headed rims are the norm. The off-white fabric is also noticeably sandier than the other examples and the decoration is fairly unusual. These differences may be explained if the dish is later than most of the others, and indeed its closest decorative parallel is a small dish dated to *c* 1625-50 (*ibid*, fig 121.385) from a pit context with associated local and other 17th-century wares.

More typical Weser dishes are represented by Figure 198.2-5 which are stylistically datable to *c* 1590-1620. All but Figure 198.4 have the typical hammer-headed rim with wavy-line decoration in red-brown and green. This is missing from the inner wall of Figure 198.3 but not from the centre, which suggests that the missing wall sherds were similarly decorated. The carinated bowl Figure 198.5 (Stratified Group 18, *c* 1625-50) differs in having an internal covering of red-brown slip as a background for cream and green wavy lines. Figure 198.4 (Stratified Group 21, *c* 1680-1700) is unusual for its small size and groups of concentric brown arcs alternating with green motifs around the rim.

Most examples of Weser slipware from Colchester occur in mid to late 17th-century contexts, perhaps because late 16th- and early 17th-century contexts are less well represented in the town.

### Werra slipware (Fabric 44B)

[Fig 198.6-9]  
Weight: 1.125 kg  
Number of sherds: 41  
EVEs: 1.18\*

A minimum of 21 vessels was found, all of them dishes or bowls. These have a hard, sandy, red-brown fabric and are covered internally and usually over the rim with a clear lead glaze which appears brown over the fabric. Decoration on Werra ware is typically executed in pale green slip with outlines and details added in sgraffito fashion. Additional green glaze highlights and darker zones of brown painting are also common. This ware was produced at several centres along the River Werra and was exported in large numbers via the port of Bremen to the Low Countries, Britain, Scandinavia and even as far as North America. Conveniently, Werra ware is often dated, with 1568 and 1653 being respectively the earliest and latest dates currently known. However, dates between 1590 and 1625 are more commonly encountered and this seems to mark the peak production period of the industry (Hurst *et al* 1986, 242-50).

Straight-sided dishes and bowls with hammer-headed rims are the commonest Werra forms in Colchester (Fig 198.6-9), although there are sherds of at least one carinated bowl (LWC AF47). The commonest design found on the walls of these forms is a swag or series of pendant arcs enclosing foliage elements and bounded by multiple concentric lines (Fig 198.6-7, 9). Spirals (as Jennings 1981, fig 32.551) and guilloches also occur though less commonly. Figure 198.8 has an external guilloche on the rim as opposed to the usual dashes and long strokes seen on most examples (Fig 198.6). Few basal fragments are large enough for the central design to be intelligible but these appear to consist largely of foliage designs. One base (MID F1; not illustrated) has drooping leaves or pods hanging from a tendril very similar to a bowl from Norwich dated 1621 (*ibid*, fig 31.542). Another (COC F65; not illustrated) shows part of a bird or an angel with outspread wings and the final digit '8' of a date (perhaps 1608 as there seems insufficient room for a preceding digit). On Figure 198.9 we appear to have part of the date '(16)19' and a terminal '...4' on another sherd (not illustrated; Stratified Group 20, *c* 1650). One base sherd has a fragmentary central design with highlights in blue (MID F39; not illustrated).

As with Weser slipware from Colchester, most examples of Werra occur in mid to late 17th- and even 18th-century contexts. A Werra sherd occurs in Stratified Group 20 (*c* 1650); another sherd occurred with a coin of 1625-44 (LWC CF20). Figure 198.6 (very abraded) and a Weser dish (Fig 198.3) were found in a pit containing a horse burial (LWC CF12) and a very worn coin of 1558-1603. Being foreign and decorative, Weser and Werra wares were, like tin-glazed chargers, almost certainly for display rather than general use and thus were likely to have been old when discarded. This would explain their occurrence in predominantly late contexts.

### Lower Rhine slipware (Fabric 44C)

[Fig 198.10-12]  
Weight: 0.165 kg  
Number of sherds: 3  
EVEs: 0.11

Lower Rhine or Niederrheinisches slipware was produced between Krefeld and Kleve to the west of the Lower Rhine. Production dates from the late 16th and early 17th centuries but only the simple dishes of the late 17th and 18th centuries were exported (Hurst *et al* 1986, 262-7). Besides Colchester, examples are currently known from 21 other British sites, almost all along the south and east coasts (Gaimster 1988b).

The fabric is orange and sandy, not unlike North Holland slipware (Fabric 31A). All the examples are from dishes. Two (Fig 198.10-11) are clear glazed internally with areas of decoration in cream slip, highlighted in places with touches of copper-green. The larger dish/bowl (Fig 198.12) has traces of marbled cream and brown slip decoration; it is very abraded and lacks glaze. Figure 198.11 came from an early 18th-century pit which produced pottery of compatible date and a clay-pipe bowl of *c* 1700-1740. Figure 198.10 may be dated stylistically to *c* 1700-1760 (*ibid*, 169, fig 3.4).

**Nieder Selters-type bottles** (Fabric 45S)

Weight: 3.670 kg  
 No of sherds: 58  
 EVEs: 8.4

The springs at Nieder Selters, east of the Rhine, between the Lahn and the Main, have been exploited for their mineral water since the late 17th century, and by the 19th century Nieder Selters water (corrupted to 'seltzer') was the most popular mineral water consumed in Europe.

Tall containers or bottles in a grey Westerwald stoneware-type fabric carried the water to Britain and Ireland in the 18th century (Hurst 1981, fig 7), but this early type of bottle has not so far been recognised at Colchester where only the brown 19th-century types have been found. The latter are tall cylindrical bottles with a narrow neck and a small loop handle attached to the shoulder. Most of the bottles have a pale grey stoneware fabric resembling Siegburg or Westerwald stoneware but covered with a pale brown glaze. Those from the excavations have not been

illustrated. A 19th-century example is illustrated by Reineking von Bock (1971, no 852), and a 'Selters Nassau' example has been published from Bedford (Baker *et al* 1979, fig 141.891).

Ten of these bottles were found on the excavations, eight of them from the same Culver Street site (1.81 W1). Several have an impressed circular stamp with a central crown surrounded by the inscription 'Kraenchen Brauren Ems', signifying that they come from Ems rather than Nieder Selters. Another bottle (TSC 142) has a lion stamp and the circular inscription 'Herzogthum Nassau' (Duchy of Nassau), dating it to 1836-66 in the Nieder Selters series (Hurst 1981, 266). There is one other unmarked bottle in a coarser brown glazed stoneware which is of square section and lacks a handle. An identical bottle from Canterbury (unpublished) has a circular stamp with the central inscription 'Gemeinde Pullna' (municipality of Pullna) enclosed by the words 'Pullnaer Bitterwasser'. These were made for water from the Karlsbad springs in Bohemia, Czech Republic (John Ashdown, pers comm). The Colchester bottle was found with a jug commemorating the International Exhibition of 1862 (BKC JF4).

---

## Chapter 10. Iberian wares

---

### An outline of contact with the Iberian peninsula

[Fig 173]

Medieval Colchester had no direct trade with Spain and the Mediterranean (Britnell 1986, 65). However, from the late 14th century Colchester cloth was exported to Spain through the agency of Italian companies operating from London (*ibid*, 65-7, 169). Exotica such as Spanish lustrewares are most likely to have reached Colchester via redistribution from London. Whatever the route, Iberian goods were certainly reaching the town during the reign of Richard II (1377-99) when a list of duties to be levied on foreign goods arriving at '...the Burgh and Havene of Colchest' included:

'4 cas sope de Spayne ijd  
1 tonne oyle de Luschebon (Lisbon) de Syvyle (Seville) ou de vyn  
egre (vinegar) le ton iijd'

(*Oath Book*, 8)

In the 18th century, the weavers of Colchester were so concerned about the adverse effects of increased duties on Spanish and Portuguese wines that they petitioned Parliament to lower them. In this petition they claimed 'That the trade to Spain and Portugal had been always beneficial to the Corporation, by taking off great quantities of woollen goods, and particularly the manufactures of that corporation in return of which great quantities of wine, and species of gold and silver have been imported' (Colchester Library scrapbook E. COL. I., source: *Ipswich Journal*, 1786). Pottery does not seem to have been imported in similar quantities.

### Spanish lustrewares (Fabric 46B)

---

#### Andalusian lustreware (Fabric 46B/1)

[Fig 199.1-4]

Weight: 0.070 kg

Number of sherds: 4

#### Valencian lustreware (Fabric 46B/2)

[Fig 199.5-6]

Weight: 0.035 kg

Number of sherds: 2

Tin-glazed lustreware was produced in Spain at Malaga in Andalusia from the 13th until the start of the 15th century. From the middle of the 14th century the emphasis in production shifted to Valencia. During the 15th century, Valencian

products eclipsed those of Andalusia in the markets of north-west Europe. Valencian lustreware, in turn, became increasingly rare during the late 16th and 17th centuries (Hurst *et al* 1986, 40-52). The fabric of both lustreware types is rather similar in being finely sandy and pink-buff to red-brown, but it is possible to distinguish the Andalusian type by the presence of reddish-brown schistose inclusions (*ibid*, 40).

Of the six examples of lustreware from the excavations, four are Andalusian. To the two Valencian examples should be added a third, a dish/plate fragment from an earlier excavation in West Stockwell Street (Hurst 1961a, fig 1), giving a total of seven sherds of lustreware known from Colchester. Only one of the Andalusian examples retains a trace of true lustre decoration. On the others, this has either decayed completely or the sherds may simply come from undecorated areas of the vessel. Two bowls or dishes and two jugs are represented by the Andalusian sherds.

Figure 199.3 is from a bowl with steeply flaring straight sides and a matt tin glaze. The inside has one or two bands of blue arabesque painting — part of a commonly used and highly stylised Koranic inscription in praise of Allah (eg Hurst 1977, fig 26 & fig 27.14). Figure 199.2 (Period 3/4.1) is a plain dish with a flanged rim; the glaze is much decomposed. A pedestal base (Fig 199.1) almost certainly comes from a form of jug that continues in Valencian lustreware and which is well represented by an example from Micheldever, Hampshire (*ibid*, fig 20.52) and by an Andalusian pedestal base from Exeter dated as early as the mid 13th century (Allan 1984, fig 38.1196). Figure 199.1 is from a context of c 1400-1450 (Stratified Group 10). Another jug sherd, Figure 199.4 (from the same context as the dish Fig 199.2), has an unusually red fabric. It is tin-glazed externally with an indistinct lustre arabesque and a decayed, greenish, clear lead glaze internally.

A small sherd of Valencian lustreware (Fig 199.5) comes from a shallow bowl with characteristic external lustre painting in a broad band with diagonal lines between. Internally the surviving decoration appears to be a radial design in blue and lustre. A second dish/plate from earlier excavations has been mentioned above. Figure 199.6 is from a Valencian *albarello* with bold vertical bars in blue and lustre. This was found in a pit containing several Raeren stoneware drinking jugs (c 1475-1550) and other pottery of the first half of the 16th century (LWC KF64). The blue painting should however date it to the 15th century (John Hurst, pers comm).

The greater number of earlier, Andalusian vessels found in Colchester as opposed to the later, Valencian type is a trend that differs from London, where Valencian sherds outnumber Andalusian (Vince 1985, 81). It may simply be that eight sherds are too few to provide any real evidence of such trends. Alternatively this trend might reflect Colchester's port status and its direct contacts with French and Low Countries trading ports.

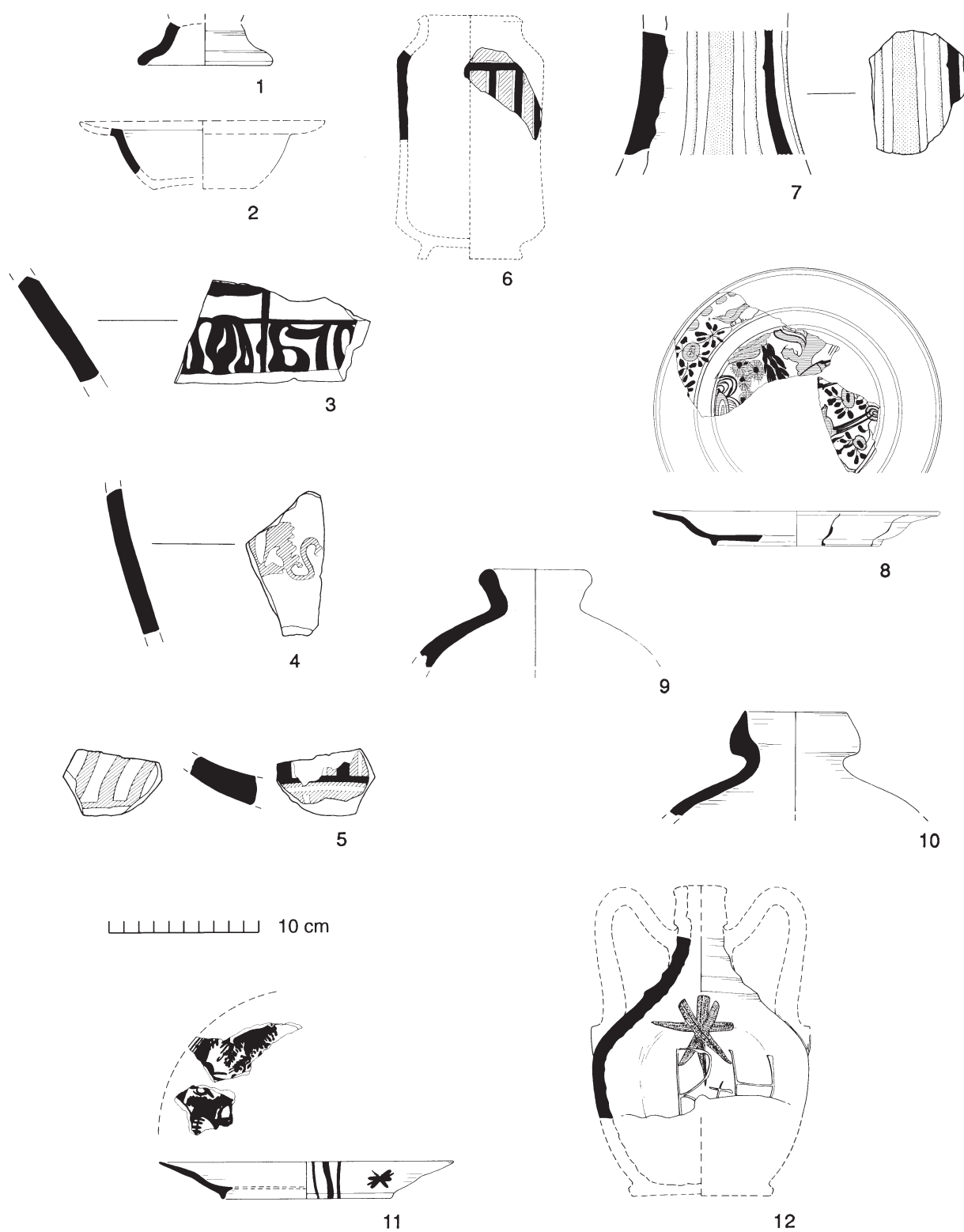

Fig 199 Iberian wares:  
 Andalusian lustreware — jug base (no 1); dish (no 2); bowl (no 3); jug sherd (no 4)  
 Valencian lustreware — dish (no 5); drug jar (no 6)  
 Cuerda Seca — ?jar (no 7)  
 Seville maiolica — dish (no 8); olive jars (nos 9-10)  
 Portuguese maiolica — dish (no 11)  
 Iberian/North African star costrel (no 12).  
 1:4, except nos 3-5 & 7 at 1:2.

### Seville (Cuerda Seca) (Fabric 46D/1)

[Fig 199.7]

Weight: 0.010 kg

Number of sherds: 1

One particularly interesting item is a sherd of Sevillian fine ware (Fig 199.7) decorated in the *Cuerda Seca* technique, whereby areas of coloured glaze are separated by bare areas made by the painting on and subsequent burning off of wax (Hurst *et al* 1986, 60, 62; identification confirmed by John Hurst). The Colchester example may come from the waisted body of a small jar or the neck of a jug. It has a sandy pale buff fabric. Decoration consists of blue and yellow vertical stripes separated by white tin-glazed stripes upon a bare background. A thin translucent tin glaze covers the interior. This is still quite a rare class of pottery in Britain with only twenty or so examples known from sites in England (London, Canterbury, Warkworth, Poole, Exeter) and south Wales (Caerleon, Usk, Penhow, Carmarthen). The vertical decoration is most closely paralleled by a small lidded jar from Penhow Castle (Lewis & Evans 1982, fig 2.6b). The simpler types as found in Wales seem to occur in contexts of c 1475-1525, and this accords well with Colchester's pit context (LWC EF24) which also contained Langerwehe and Raeren stoneware jugs along with local coarseware of compatible date. The area in which this pit was located was once the late medieval backyard of a stone building (Building 28; see p 5), and it seems probable that this and other pits were dug before the construction of a new south-westerly room (Room 8) and the laying down of new daub floors later sealed by a 16th-century floor of glazed tile.

### Seville *maiolica* (Fabric 46D/2)

[Fig 199.8]

Weight: 0.055 kg

Number of sherds: 6

EVEs: 0.08

A single plate (Fig 199.8) has recently been identified as a Seville product. This was originally identified as an example of Ligurian *maiolica*, perhaps from Savona in north-west Italy (Michael Archer, pers comm, 1988), primarily on the basis of its shape and decoration. The latter resemble the better known Ligurian *berettino* (blue on blue) ware (Hurst *et al* 1986, 26-30), except that the Colchester piece has a blue on white colour scheme and, for convenience, is perhaps best described as a *maiolica*. Subsequently, however, a sherd from the plate was examined by neutron activation analysis (NAA), and this revealed a surprisingly close match with the composition of other Seville tin-glazed pottery including Seville copies of Ligurian *berettino* (M J Hughes, pers comm, and forthcoming).

The plate has a pinkish fabric covered all over with an off-white tin glaze which is pitted on the underside. The design is fragmentary but clearly derived from late Ming Chinese porcelain with birds, vegetation and a water pool in

greyish-blue tones with radiating strokes on the underside.

Exact copies of Ligurian *berettino*, and perhaps other Ligurian wares, are thought to have been produced in Seville towards the middle of the 16th century, and there is documentary evidence for the presence of Ligurian potters in Seville in 1574 (Hughes forthcoming). NAA in 1997 led to the identification of two examples of Seville *berettino* from the London Mint site, but no example of blue and white Seville *maiolica* like the Colchester piece seems to have been recognised from a British site until now. The design on the Colchester plate is more overtly Chinese than the latest Ligurian parallels illustrated in Hurst *et al* (1986, fig 11.20-22) which are dated c 1575-1625.

On Dutch and English tin-glazed wares, similar 'bird on a rock' designs are generally typical of the first half of the 17th century (eg see Fig 164.e, dated c 1630-40) and this is probably the date of the Colchester plate too. It came from a large late 17th-/early 18th-century pit on the Lion Walk site which also produced several near-complete English tin-glazed chargers of the first half of the 17th century (LWC AF3; see p 237). All these decorative wares had presumably been well curated for at least half a century or more prior to deposition.

### Olive jars (Fabric 29A)

[Fig 199.9-10]

Weight: 1.310 kg

Number of sherds: 29

EVEs: 2.13

Also from the Seville area, this is usually the commonest post-medieval pottery of Spanish origin to be found on British sites.

The fabric is coarse and pink, often greyer towards the inner surface which is commonly green glazed. The outer surface is covered with a buff slip (Hurst *et al* 1986, 66-7). In form and fabric the Spanish olive jar is a descendant of certain Roman amphoras, and it is petrologically very similar to its much rarer medieval predecessor which is also believed to originate from the Seville area (Williams 1984, 145). Post-medieval olive jars span a long period from the second half of the 16th century until well into the 18th century. Attempts to date the jars on the basis of variations in form have proved somewhat unconvincing, and it is possible that such variations may be a reflection of different uses, eg for oil, wine or honey (Hurst *et al* 1986). A minimum number of ten or eleven vessels is represented. Both globular and carrot-shaped types are present. In addition to the excavated examples there are three complete vessels (all unglazed) in Colchester Museum (not illustrated). Only the carrot-shaped example (CM 3365.15) can be attributed with any certainty to Colchester where it was found at Lexden (form and rim as Hurst 1986, fig 29.81). A second identical example (no number) is encrusted with barnacles and thus may have been found off the nearby Essex coast. The third example, also unnumbered, is of globular type (form as Hurst 1986, fig 29.79).

Figure 199.9 is of globular form, unglazed but covered all over with a cream slip (general 17th-century context). Figure 199.10 has a dark matt green glaze inside. An identical rim (LWC B27) was almost certainly derived from Stratified Group 20 (c 1650). This group probably represents an apothecary's dump and it produced several other sherds of Spanish olive jar. Fragments from a carrot-shaped jar (LWC BF34, not illustrated) occur in a context with over a dozen clay pipes of 1640-60. Half the olive jars from the excavations come from a relatively restricted area of Lion Walk (areas A, B & S) and this concentration adds some weight to the notion of dumped apothecary's material.

### Miscellaneous Iberian green glazed wares

(Fabric 29X)

Weight: 0.035 kg  
Number of sherds: 1

There is a single sherd (not illustrated) in this fabric which is sandy, micaceous and reddish-buff, somewhat streaky, with white and occasional red-brown (metamorphic?) inclusions and a laminated fracture. The outer surface is buff and possibly slipped; the inside is covered with a matt, granular lichen-green glaze, perhaps alkaline. It may come from the side of a thick-walled jar and has a superficial resemblance to Spanish olive jars. A Spanish or Portuguese origin is equally possible (Alan Vince, pers comm, 1987). A medieval date is likely although the context is late (1.81 A789).

### Merida-type ware (Fabric 57)

Weight: 0.065 kg  
Number of sherds: 7

At least three vessels in this ware are represented but only by body sherds (not illustrated). This has fine orange-red micaceous fabric. Merida-type ware is now known to have been produced in an area centred in the Alentejo of Portugal but stretching as far east as Merida in Spain (Hurst *et al* 1986, 69-74). Red micaceous pottery was produced in this area from medieval times until the present day. One of the commonest forms traded was the standing flat-based costrel with a pair of arched handles (*ibid*, fig 32.90). This form was produced in the 13th century and is still produced today. From their curvature it seems likely that most of the sherds from Colchester come from vessels of this form. One sherd, however, retains a vestige of rim and is evidently from a much wider vessel such as a deep bowl or a jar (BKC JF3). None occurs in useful contexts but, as they have a fine orange red fabric, they are more likely to date to the 16th or 17th century than before this (*ibid*, 69).

### Iberian/North African star costrels (Fabric 62)

[Fig 199.12]

Star costrels are believed to date to the first half of the 17th century and until recently were thought to have come from Seville (Hurst *et al* 1986, 63-4). Thin-sectioning of the fabric has, however, proved inconclusive and they have not yet been exactly paralleled in Spain itself. The kicked-up handles would suggest a south Iberian or North African origin. It is also now realised that the glaze is a clear lead glaze over a white slip and not a thin tin glaze as was previously thought (John Hurst, pers comm).

No examples of this form were recognised from the 1971-85 excavations, but a large fragment was recovered during the construction of the Wyre Street Arcade in 1930 (Fig 199.12). It is of standard appearance, slightly flattened and with a dark red painted star on both sides. The fabric is fine, yellow-buff and covered externally with a white slip and a clear glaze. The broken edges and handle scars are worn and an unusual feature, on one side only, is a graffito (post-firing) which appears to show the initials 'B+H'.

### Portuguese *maiolica* (Fabric 46F)

[Fig 199.11]  
Weight: 0.020 kg  
Number of sherds: 7  
EVEs: 0.04

A single dish or plate in this fabric has been identified (John Hurst, pers comm). It probably dates to c 1625-60 and was found in a pit context of c 1680-1700 (Stratified Group 21). This type has been discussed by Hurst *et al* (1986, 67-8); it is fairly rare in Britain owing to the presence here of similar blue and white delftware industries producing similar copies of Chinese porcelain.

The excavated example (Fig 199.11) has a fine pale buff fabric covered all over with a white tin glaze showing pinkish where thin. Decoration is carried out in varying tones of greyish-blue. Because the vessel is so fragmentary, the design is all but unintelligible, but as with most Portuguese *maiolica* it is almost certainly a copy of late Ming (Wan Li) designs showing sacred symbols and foliage. The exterior is decorated with stars and groups of radial lines typical of this style.

### Iberian storage jars (Fabric 53)

There is a single complete example of this form which was found in the castle yard in 1844 (CM 209.1860). This was published by Cunningham (1982a, fig 34.113), but is briefly reconsidered here in order to include it in the catalogue of imports from the town and to present new information as to its possible source.

This remarkable vessel stands a little over 1.27 m tall. It has a globular body tapering to a narrow flat base and a cylindrical neck with a hammer-headed rim. The fabric is hard, pale brownish-grey and contains numerous black grits (3-5 mm across) probably of igneous origin. Most of the exterior, which is unglazed, is covered with a pale grey slip which avoids the twelve thumbed horizontal cordons decorating the body. The neck and shoulder are decorated with incised wavy and criss-cross lines. Two holes (post-firing) pierce the lower body at different heights, and these probably served to draw off different qualities of olive oil or wine settled within the vessel.

There is a tradition that the jar was found outside the main entrance to the castle, on the south side, and also that the jar is of 17th-century date. There does not appear to be any basis for these statements although they could be substantially correct. It is reasonably certain, at least, that it is post-medieval and its discovery in 1844 (presumably buried?) would seem to suggest an 18th- if not 17th-century date.

Large storage jars of this general type, known as *tinajas*, were produced at a great many centres throughout the Iberian peninsula, each region producing its own distinctive shapes and decoration. Unfortunately the great diversity of these production centres is poorly documented for the post-medieval period.

It has been suggested that the source of the Colchester jar may be the Lisbon area of Portugal (*ibid*, 375, suggested by John Hurst), and this still remains a possibility. A drawing and description of the jar have also been studied by Señor Jaime Coll Conesa, director of the National Museum of Ceramics in Valencia, Spain. Señor Coll Conesa, while unable to locate an exact parallel, suggests the north-west of the Iberian peninsula as the most likely source, probably

Galicia where large wine or water containers with thumbed cordons are known to have been made (eg at Portomourisco and O Seixo). In the adjoining region of Asturias, there was also a tradition of decorating the upper third of storage jars with incised wavy lines similar to those on the Colchester example

In November 1996, an almost identical jar was exhibited at the Olympia Fine Arts and Antiques Fair in London. This particular jar had been purchased in Gujerat in north-west India where jars of this type are fairly common and presumed to be of 19th-century date and imported from North Africa (Michael Wakelin, antiques importer, pers comm). While a north African source cannot entirely be discounted, it is suggested that the case for an Iberian origin is somewhat stronger. The Indian connection, which at first seems so surprising, might be explained by the trading activities of the Portuguese with their colony and other trading posts at Goa and elsewhere along the west of coast of India. If this suggestion is correct, then the original suggestion of a Portuguese origin for the castle jar may also be correct.

How and why such a large and complete vessel came to be buried outside the castle is obscure. The castle keep was in ruins by 1700 although part of it remained a gaol until 1835. There may have been lean-to houses built up against the walls in the late 17th century, but these would have been demolished by Charles Gray who acquired the castle in 1727. In the following decades, Gray landscaped much of the bailey and remodelled parts of the keep to make it resemble an Italian or Roman villa. Elsewhere in the bailey, Gray constructed a rustic stone arch and other follies (*VCHE*, 9, 245-7). Given these developments, it could be that the large Iberian storage jar was acquired by Gray to form an ornamental feature in the classical gardens he sought to create around the castle.



## Chapter 11. Italian wares

### An outline of contact with Italy

Medieval Colchester had no direct contacts with Italy outside of ecclesiastical matters. From the late 14th century onwards, Colchester cloth along with other Essex cloth was exported to the Mediterranean by way of Italian shipping agents based in London and Southampton (Britnell 1986, 65-7). No medieval Italian wares are known from Colchester. One must assume that Italian wares reaching the town in the post-medieval period did not arrive directly but were redistributed from English or Dutch ports with closer links with the Mediterranean.

### Italian *maiolica* (Fabric 46E)

A large polychrome drug jar (Fig 161.9), identified as either Netherlands or Venetian, has been considered along with other Netherlands tin-glazed wares (see p 235).

### Montelupo

[Fig 200.1-2]  
Weight: 0.170 kg  
Number of sherds: 4

This has a fine buff fabric with an overall tin glaze with polychrome decoration. Montelupo lies in Tuscany between Florence and Pisa. Production of garish polychrome *maiolica* began here in the late 15th century and continued, with increasingly debased designs, into the 18th century. During the 16th century Montelupo dominated the Mediterranean and Atlantic trade in polychrome *maiolica* and it is to the 16th and early 17th centuries that most British examples date (Hurst *et al* 1986, 12-24).

Fragments from four separate vessels were found on the excavations. At least one other Montelupo vessel was found during building operations earlier this century at Head Street (CM 1188.1935). The base of a dish (Fig 200.2) was found in Stratified Group 18 of c 1625-50 and is the earliest stratified piece. This probably comes from a fairly small dish with a flanged rim. The outside has a plain tin glaze while the interior has (towards the base) multiple concentric lines

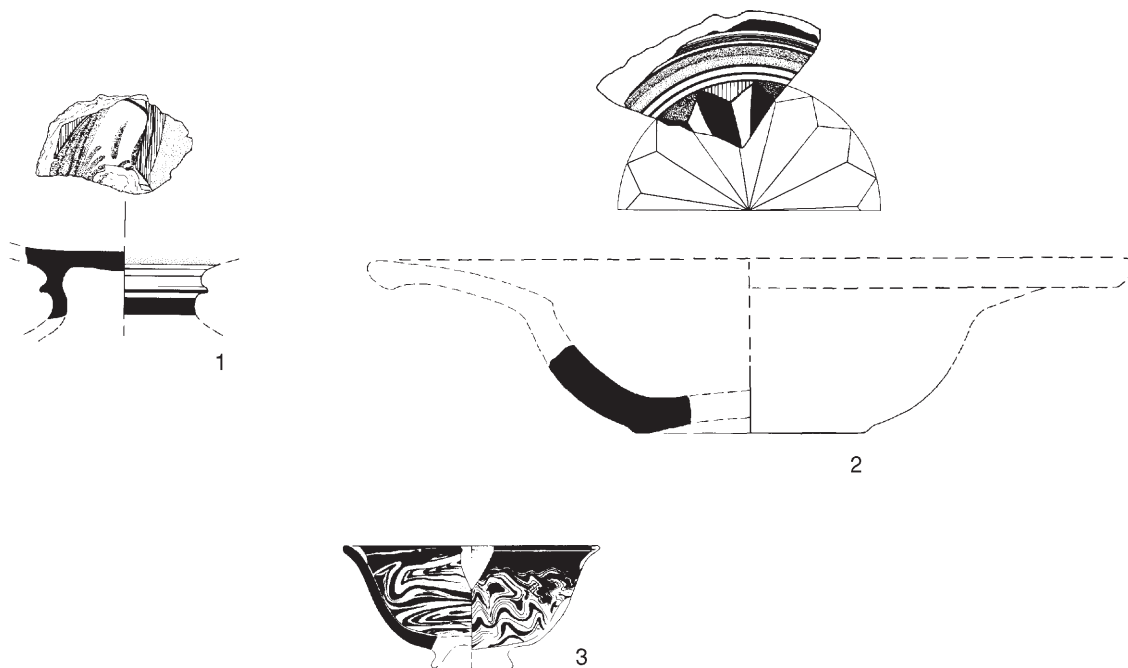

Fig 200 Italian wares:  
Montelupo maiolica — tazza (no 1); dish (no 2)  
North Italian marbled slipware — bowl (no 3).  
1:4, except no 2 at 1:2.

and bands in differing tones of blue and ochre, while the central medallion shows part of a blue and white radial compass-like motif with brown and green fillers. The other three excavated vessels and the vessel from Head Street are all *tazze*, fairly large hemispherical bowls on an open pedestal base with bands of polychrome decoration on both sides and a central medallion inside. The three excavated fragments come from around the thick area where the bowl and pedestal meet. Figure 200.1 is the largest fragment and the medallion probably shows leaves or fruit in green, yellow and ochre with purple veins, typical of the 17th century (Hurst *et al* 1986, fig 6.10, c 1600-50; Fig 200.1 from MID F43, a 17th-century pit). The other two fragments are too small and too highly decorated for normal illustration and so are described as follows:

**LWC C19:** *tazza* fragment with chequerboard medallion in blue, white and ochre defined by black outlines. External green and ochre bands on the pedestal stem (as *ibid*, fig 4.8, c 1575-1625).

**LWC CF19** (second half 17th century): *tazza* fragment from lower wall of bowl. External bands in differing tones of green, yellow and ochre outlined in black with principal dark blue band decorated with ochre rosettes and sgraffito leaves. Internal blue and ochre bands with central medallion possibly depicting a landscape in blue and yellow with a spire or pinnacle in ochre with black outlines (as *ibid*, fig 5.9, c 1575-1625).

The Head Street *tazza* is also described:

**CM 1188.1935** (Post Office site, Head Street, front): rim sherd and large portion of pedestal base. Slightly thickened everted rim with polychrome bands and sgraffito rosette decoration almost exactly as *ibid*, figure 4.8. Pedestal base decorated with broad blue bands.

### North Italian marbled slipware (Fabric 39)

[Fig 200.3]  
Weight: 0.050 kg  
Number of sherds: 3  
EVEs: 0.14

A minimum of two vessels, all bowls, came from the excavations. This has a finely sandy, hard red fabric. Vessels are most commonly covered with a white slip which was shaken or 'feathered' to produce a marbled effect contrasting with the underlying red-brown. Alternatively brown and sometimes green slips were added and worked into a marbled effect. All vessels have a clear lead glaze. Marbled slipwares were produced at Pisa and other north Italian centres including the Po valley, though some were also produced in France at Provence. Narrow costrels found in this ware are as yet unparalleled in Italy although the wider type is. Nevertheless, most marbled slipware exported around the Mediterranean and to Britain is believed to have come from Pisa. Most of it dates to c 1600-1650, though some has been found in Dutch contexts of c 1575-1625 (Hurst *et al* 1986, 33-7).

The Colchester examples come from late 17th- or 18th-century contexts on the Middleborough site outside the town wall. Figure 200.3 came either from Stratified Group 21 (c 1680-1700) or from a similarly-dated pit (MID F29).

This small bowl is covered on both sides with a dark brown slip overlain with pale green marbled slip on the inside and cream slip on the outside. It is glazed on both sides.

In addition to these, there are three complete marbled slipware costrels with lion-head lugs in the Colchester Museum (as *ibid*, fig 15.32). At least one of these was found in Colchester in the last century (CMR 1923, pl 9; CM 4340.22), and the other two might also come from Colchester (CM 195.1901; 4873.24).

### Italian oil jars (Fabric 54)

[Figs 201-3]  
Weight: 2.900 kg  
Number of sherds: 3

A dozen jars of this type are known from around the town, most have been re-used as garden jars but fragments of three jars were recovered from excavations in Colchester (two from the 1971-85 excavations). Three other jars, originally from Coggeshall, occur at Mount Bures, seven miles (11.2 km) west of Colchester, and a further three jars are known at Beaumont-cum-Moze, twelve miles (19.2 km) to the east.

The jars have a hard pale brick-red fabric with darker surfaces. Some examples are pale orange-brown and one is pink-buff with a lighter external wash of clay or slip. In most examples the fabric has a hard terracotta character with little or no visible quartz sand. The predominant inclusions are moderate to abundant hard red-brown clay pellets, mostly around 1 mm across but occasionally up to 2 mm. These have a mudstone-like fracture and are most prominent where the surface of the vessel has been weathered. There is abundant fine white mica up to 0.1 mm across (rarely to 0.5 mm), some sparse to moderate red iron oxide up to 1 mm across, and also some sparse white calcite or calcareous inclusions up to 0.75 mm. Vessels are unglazed externally, but most examples have a thin clear lead glaze all over internally.

Forms can be quite large and heavy. Examples from the town range from 0.58 to 0.94 m in height, of which the largest is illustrated here (Fig 201.1). One empty jar (0.86 m high) weighs 42 kg. The lower two-thirds of the form is a straight-sided truncated cone with a flat base, while the upper third is rounded with a heavy lid-seated rim and a pair of vestigial arched lug handles. Below the handles there is often an applied plaque or circular stamp bearing initials and other devices. Jars with applied plaques are thought to be 18th century and these commonly occur with the scheme of white slip decoration shown here. On some examples, however, the slip is very faint or has worn away completely. Nearly all the stamps shown here (Fig 202.2-7) have raised lettering and occur on slip-decorated jars. Exceptions to this are Figure 202.6 which has sunken lettering, and Figure 202.7 which occurs on undecorated jars, while Figure 202.3 is from a very worn jar that may originally have been decorated.

Because of their size, the jars were hand-made, perhaps coil-built. Their hand-made character is clearly seen in the

excavated pieces which show random internal wiping and irregularities in contrast to the smooth exterior. Rims were added separately and the whole vessel may have been finished off on a turntable. Handles were then added and stamped plaques applied beneath these. It is not clear whether a previously moulded plaque was applied or whether a blank plaque was applied and then stamped, possibly the latter as the edge of one stamp (Fig 202.2) is sunk quite deeply into the body clay. Slip painting may have been done with the fingertip whereas the broad slip strokes on top of the handles seem to have been done with the thumb (Fig 201.1 and Fig 203, right).

These jars have sometimes been confused with the smaller amphora-like Iberian oil or olive jars (Fabric 29A) of the 16th to 18th centuries but, apart from their common function, the forms have little in common. Examples occur throughout Britain, some are known from the Netherlands, and there are many examples in the West Indies and the former American colonies, particularly Virginia (Ashdown 1972; Noël Hume 1980, 143-4). Noël Hume (*ibid*) assumes an Iberian origin for the jars though on no very firm evidence. Ashdown suggests an Iberian and/or Italian origin, and devotes much attention to the links between oil jars used as shop signs in Britain and the Italian olive oil trade (Ashdown 1972; 1974; 1975).

Evidence for an Italian source for this specific form of oil jar is now much more certain. Samples of oil jar fabrics submitted for neutron activation analysis (including a sherd from Fig 202.3) proved to be chemically very similar to Tuscan and north Italian redware fabrics (M J Hughes, A Vince, pers comm). Besides this there is the evidence that some of the stamped inscriptions on the latest jars to reach Britain bear the names of Italian potters or oil merchants along with the names of towns in Tuscany, including Montelupo (Ashdown 1972, 151).

There is little definite evidence from the Mediterranean area itself. However, no Spanish jars with this form have yet been noted, but very similar garden jars, perhaps descendants of the oil jars, can still be seen today in many parts of Tuscany and adjoining areas.

Ashdown distinguishes three types of oil jar (*ibid*, 152; Ashdown 1974, 168). Type 1 jars with a low rim and bearing plaques are dated to the 18th century (*ibid*, fig 6). Most of the Colchester jars correspond to this type (Fig 201.1). Type 2 jars are plain though also with a low (but apparently thicker) rim. They were commonly used as oilmen's shop signs in the London area and are dated to the 19th century (Ashdown 1974, fig 3). These also occur at Colchester but are less common. Type 3 'garden jars' have high rounded rims and are often impressed with Italian maker's marks. This type is dated to the late 19th and 20th centuries. Only a single (unmarked) example of this type occurs at Colchester, but the three examples at Beaumont-cum-Moze are of this type, two bearing the inscription VINCENZO BITOSSI MONTELUPO on the body and a monogram shield device stamped on the rim.

Oil jars and oil shops in England are referred to from the 17th century (Ashdown 1972, 149), but the form and source of these early jars is unknown and could represent a number of Mediterranean sources. Oil jars of 'Italian' form (some in straw casings) appear on the trade cards of London oilmen from around 1739 onwards (Heal 1957, 140-41).

Precise dating evidence for this type is provided by two similar paintings by Samuel Scott of the Old Custom House

Quay in London, dated 1757. These show both an open oil jar of 'Italian' form and a second unopened example encased in a straw framework (Ashdown 1972, fig 8 & 1975, 239). In Virginia, jars of this type (with plaque and slip painting) are said to have been common in the period c 1745-80 (Noël Hume 1980, 144). In Jamaica the earliest archaeologically attested example comes from a context of c 1720, but they were probably imported for some time before this (Richard McClure, pers comm). The earliest dating evidence, however, comes from a shipwreck site on the Goodwin Sands off Ramsgate and Deal in Kent. Fragments of at least two Italian oil jars were found on the upper deck of a ship identified as the 70-gun 'Stirling Castle' which sank in the Great Storm of the 27th of November 1703 (Perkins 1981 and pers comm). Pottery from the wreck has yet to be fully studied and published, but the oil-jar rims examined have the same profile as Figure 201.1 and bear traces of white slip decoration (examples in Ramsgate Maritime Museum and Bleak House Museum, Deal). No applied plaques were observed, but this part of the vessels was either not recovered or remains in store.

#### Catalogue of Italian oil jars from Colchester

1. Type 1 (Fig 201.1 and stamp detail Fig 202.2). Private ownership, Church Walk. Complete jar with 'CB' stamp, used as garden jar. Height 0.94 m. Lower wall above base pierced with three holes. Upper part cracked and repaired with modern rivets. One of a pair of identical jars (with no 2 below) brought to Colchester by the May family of Ipswich (Suffolk) before 1940. Originally stood in the garden of a Georgian house called 'St Matthew's' on corner of St Matthew's Street and Mill Street, Ipswich. A photograph of c 1890 shows the jars in position.
2. Type 1 (not illustrated). 'CB' stamp. Details as above but more worn.
3. Type 1 (Fig 203, left, stamp as Fig 202.2). From a watching brief at 11 St John's Street (X369/9/83a). Unstratified find with other post-medieval pottery. Body sherd with handle, thin slip painting and 'CB' stamp. Unworn.
4. Type 1 (stamp Fig 202.3). Private ownership. Formerly at 399 Ipswich Road. One of a pair of garden jars (with no 5 below). Complete (restored) jar with 'IF' stamp and 'Florentine lily' emblem (Ashdown 1972, 151, fig 7C). Height 0.64 m. Very worn external surface, no evidence of slip decoration survives. Formerly property of the late Mrs R Beard of Ipswich Road and before that of her husband R B Beard (mayor of Colchester 1911) who had the jars earlier at Cambridge Road. There was a tradition that the jars were originally brought over from Belgium.
5. Type 2 (as Ashdown 1974, fig 3). Provenance details as no 4. Plain, heavier rim, less shouldered. Thicker internal glaze. Height 0.86 m. Textile impression on body.
6. Type 1 (stamp Fig 202.4). One of a pair of garden jars (with no 7 below) outside the front entrance of Hollytrees Museum. 'IF' stamp. Traces of white slip painting on rim and neck. Height approximately 0.58 m. Very worn/disintegrating (recently collapsed). A photograph of c 1930 shows there were originally four such jars outside the museum entrance.
7. Type 1 (stamp Fig 202.5). Provenance details as no 6. Complete jar with inverted pear-shaped stamp with initials 'TM' and other devices. Possibly stamped directly on to body? Traces of white slip painting as on Figure 201.1. Height 0.65 m.

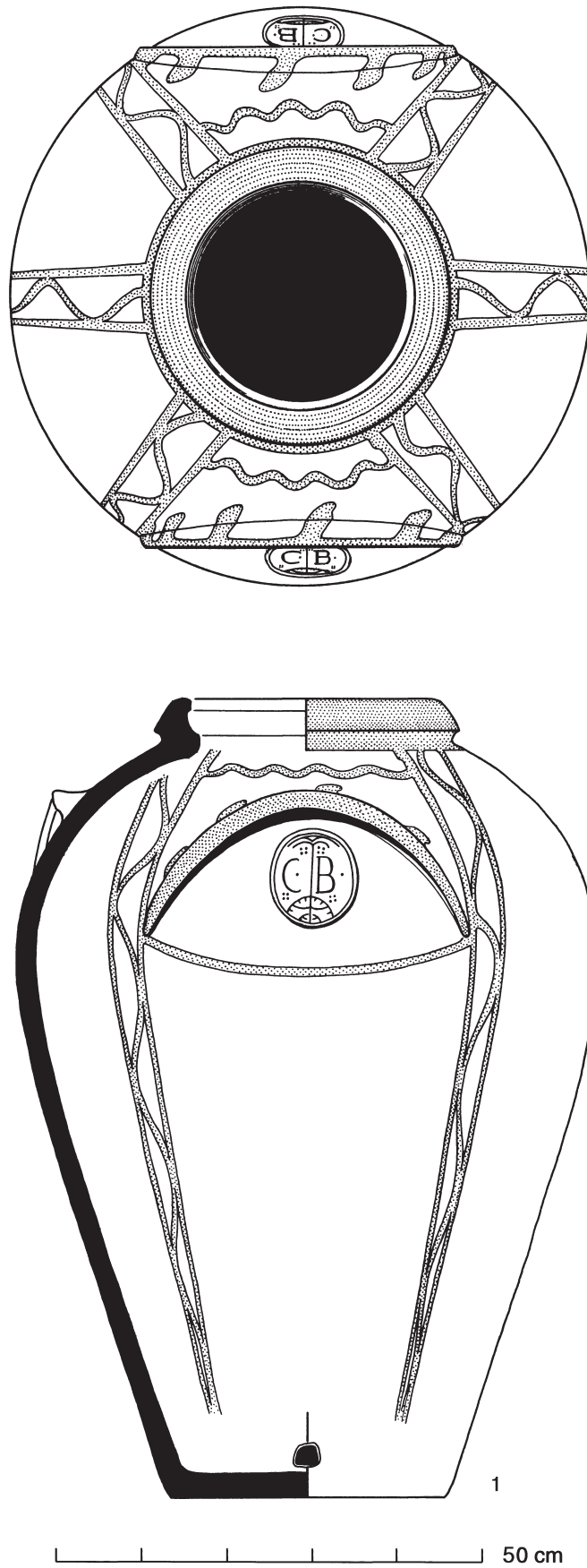

Fig 201 Italian oil jar (no 1). 1:8.

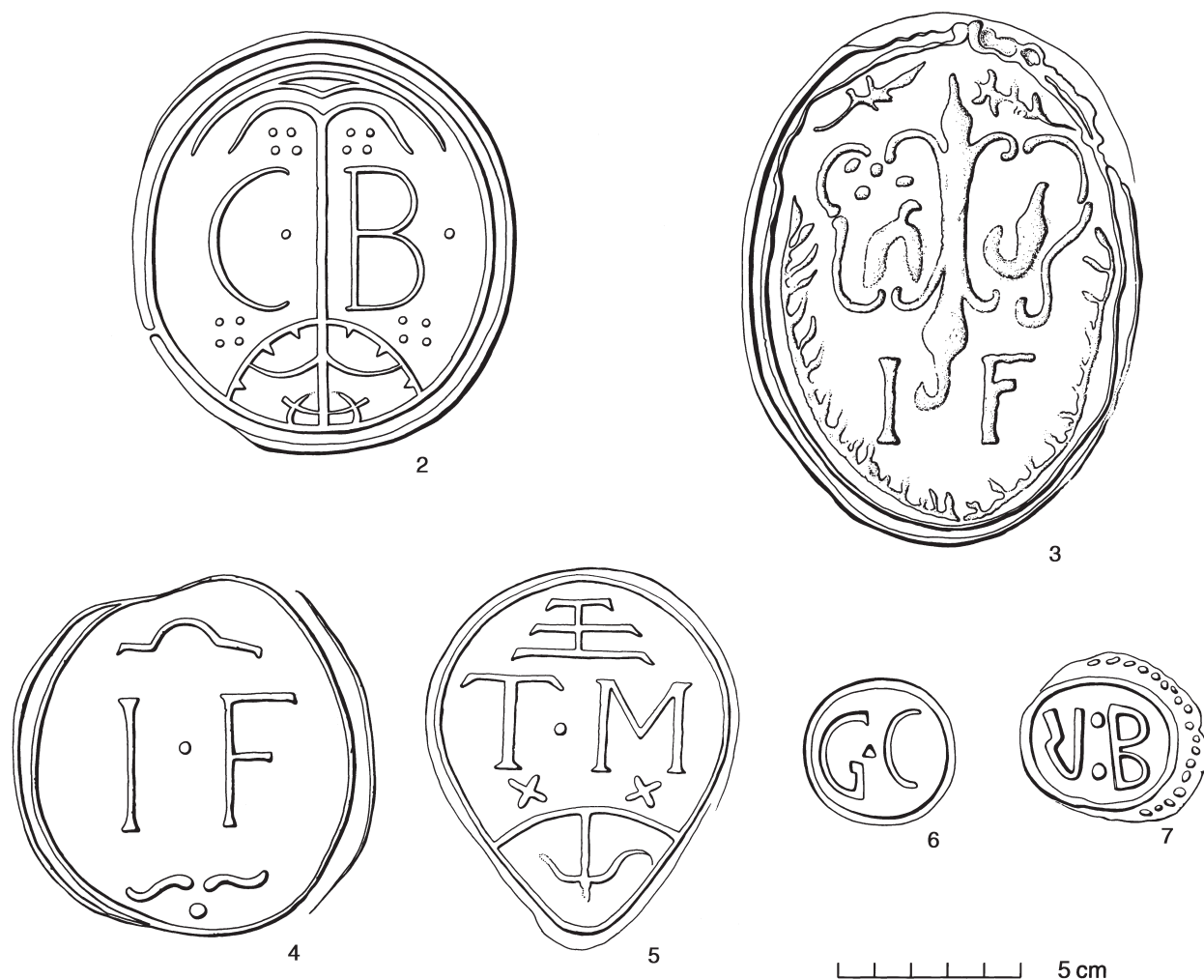

Fig 202 Italian oil jars: detail of stamps (nos 2-7). 1:2.

8. Type 1 (Fig 203, right, stamp Fig 202.6). Balkerne Lane excavation (BKC EL25). Layer containing early/mid 19th-century pottery. Two body sherds from shoulder of same vessel with part of handle and small circular 'G.C' stamp in sunken characters. Fabric paler than usual: pink-buff though with the usual red-brown inclusions. Exterior covered with a thin white slip or wash over which details in white slip have been painted. The slip design appears the same as Figure 201.1 except that the wavy horizontal line above the handle has been omitted (the same omission occurs on one of the complete Mount Bures jars with the same stamp though with normal red fabric). In addition the sherd has traces of bluish-grey (?originally green) pigment on the underside of the arched handle, and there are traces of reddish-brown pigment below this and in the impression of the stamp. The presence of paint on this jar could suggest that at one time it was used as an oilman's shop sign. Evidence for this is suggested in Larwood and Camden-Hotten's *History of Signboards* (1868) where it is stated that 'now-a-days the jars, painted red and green, are the usual oilman's sign, representing those vessels in which oil is kept in Eastern countries' (p 397).
9. Type 2 (stamp Fig 202.7, form as Ashdown 1974, fig 3). Private ownership. Northgate Street. Complete garden jar, probably brought from Boxted, Essex within the last 20 years. Plain except for small 'V:B' stamp under handle with some beading along the right edge. Faint textile impressions here and there. Pierced (recently) through base and sides for drainage. Height 0.625 m. Identical jar at Mount Bures (0.810 m) but without raised stamp border and beading.
10. Type 1 (not illustrated). High Street, Angel Yard excavations (40.86 F230). Excavations here in 1986-7 (outside the brief of this volume) recovered most of a single oil jar as more than a dozen large fresh fragments. Found in a brick-lined pit with large quantities of 'feather-edged' and transfer-printed Pearlware of c 1825. Height unknown but fairly large (rim diameter 0.310 m). Form as Figure 201.1 with similar scheme of slip painting. No stamp present but these areas not present on sherds examined. Wall above base pierced for use as garden jar so may have stood in the courtyard of this former coaching inn.
11. Type 2 (not illustrated, form as Ashdown 1974, fig 3). Complete jar in reserve collection of Colchester Museum (unaccessioned). Plain except for traces of white slip painting. Height 0.59 m.
12. Type 3 (not illustrated). Complete jar at entrance to 'crypt' in Colchester Museum (unaccessioned). Plain with simpler more



Fig 203 Italian oil jars: excavated sherds with stamps and white slip painting — right example (cat no 8) from Balkerne Lane, possible shop sign with traces of red and green pigment under handle; left example (cat no 3) from 11 St John's Street..

upright lid-seated rim compared to preceding jars. At maximum body girth there is a sharp change of angle. Finer 'terracotta' fabric than the preceding examples. Glaze runs indicate firing in inverted position. Stacking scar on rim. Blackened (?possibly sooted) and polished exterior. Height 0.805 m. The simpler rim section is shared by the 'Montelupo' jars at Beaumont-cum-Moze.

The Colchester oil jars represent all three types described by Ashdown with type 1 being the commonest. Some features only briefly mentioned in previous literature, such as the slip decoration, are better represented here than in any previously illustrated examples. There also hybrids of types 1 and 2 which do not appear to have been previously noted.

It is evident from Colchester examples that slip decoration was a regular feature of the 18th-century type 1 jars. At Colchester and Mount Bures there is also evidence for an intermediate stage between type 1 jars (low rims and plaques) and the supposedly 19th-century type 2 jars (low but thicker rims, without plaques). Two complete jars (including no 9) have the form and plain appearance of type 2 jars but with the addition of a small circular stamped plaque (Fig 202.7), apparently a vestige of Ashdown's type 1 plaques. A late 18th- to early 19th-century date might therefore be suggested. The small circular 'G.C.' stamp of Figure 202.6 also represents a diminution of the larger more elaborate type 1 plaques and could be a development of the later 18th century. The somewhat heavier rim on the Mount Bures jar with this stamp supports this view.

A further development is represented by the apparent survival of slip-painted decoration on otherwise plain jars of type 2 (19th century), as evidenced by the jar in Colchester

Museum (no 11). Survival of slip decoration into the early 19th century is also suggested by the Angel Yard jar (no 10), unless it was old when broken, although its condition does not suggest this.

All the Colchester stamps, except Figure 202.7, can be paralleled elsewhere in Britain or abroad (Ashdown 1972, fig 7), although Figure 202.2, 4 and 5 represent either variants or better-preserved examples than those published previously. The circular 'G.C.' stamp has a parallel in the Museum of London and another from Jamaica (Richard McClure, pers comm). The significance of the stamps has yet to be researched. Some of them could represent the earlier trade marks of olive oil companies or potting families that survived into the 19th century when some impressed names appear in full. Figure 202.7, for example, could be the earlier mark of the Vincenzo Bitossi named on type 3 jars, and Figure 202.2 could be an ancestor of the Carlo Bitosso also named on later jars (*ibid*, 151).

No oil-jar lids have been found at Colchester though it is possible these could have been mistaken for tile. These are disc-shaped with three oblique finger holes in the upper surface (*ibid*, fig 3B). They are mostly known from shipwreck sites although an example has been published from Southampton (Platt & Coleman-Smith 1975, fig 208.1340).

With the exception of Ashdown's survey of oil-jar shop signs in Greater London (Ashdown 1974; 1975), no other concentrations of oil jars as high as that from Colchester have been reported from elsewhere in Britain. Their survival and recognition have clearly been influenced by their re-use as garden jars, but the original reason for their (apparent) preponderance in the Colchester area requires some explanation.

Olive oil had many uses in the past. It was used for cooking, lighting, soapmaking, lubrication, and it also had a number of medicinal uses (Ashdown 1974, 170; see also A Rees's *The Cyclopaedia*, 25 (1819)). The reasons for the concentration of oil jars in Virginia and the West Indies may differ from the reasons for their concentration at Colchester. In Virginia there is evidence that some jars, at least, were used as soap containers, and in the West Indies many jars are used (probably re-used?) as water jars (Noël Hume 1980, 144), but it is suggested here that the reason for so many oil jars at Colchester is closely linked with the town's important post-medieval textile industry.

Olive oil was an important ingredient in the textile industry in post-medieval Britain. It was used as a lubricant at the combing and carding stage of manufacture where it rendered the raw wool more pliable and less likely to tear in the teeth of woolcombs (Mann 1971, 282-4; Hartley 1939, 219-21). Hartley is very specific about the connection between 'the great red oil jars that served as signs for the London oil shops' and the woolcomber's trade, and she illustrates an empty jar used as a woolcomb pot containing a charcoal fire to heat the iron woolcombs (*ibid*, 220). This might explain the sooting observed on the castle jar above (no 12), although this was external rather than internal. Woolcombers were sufficiently numerous in Colchester for them to hold

their own annual procession, until at least 1782, in honour of St Blaize their patron saint (*VCHE*, 9, 173).

Other types of oil were occasionally used, but olive oil was 'esteemed the best for this purpose' from an early date (*Encyclopaedia Britannica* (1771), 211). Sudden increases in the price of olive oil, occasioned by the war with Spain in 1743 and by the failure of the Italian olive harvests, were a source of much grievance to British clothiers and led to a number of Parliamentary petitions to remove the import duty on this essential commodity (Mann 1971, 284; Minchington 1963, 55).

The main source of Italian olive oil was Gallipoli in the south-east of the country, though the best olive oil was said to come from Lucca and Florence in Tuscany and was exported through the port of Leghorn (Mann 1971; Ashdown 1974; see also *The Penny Cyclopaedia*, 16 (1840), 427-8). London was the main redistribution centre for imported oil and from here cargoes of oil and other Mediterranean goods were sent up the coast to Colchester and other ports. In 1698-9 the main export sent from London to Colchester was raw wool for the textile industry and this, significantly, was followed in importance by oil and then other goods (*VCHE*, 9, 86).

## Chapter 12. Far Eastern wares

### An outline of contact with the Far East

Colchester's links with the Far East were the same as those of the rest of Britain. They were probably not direct until the 18th or 19th century (ie military/colonial) and are unlikely to have influenced the importation of Far Eastern wares to any significant degree.

### Martabani stoneware (Fabric 58)

[Fig 204]  
Weight: 0.050 kg  
Number of sherds: 1  
EVEs: 0.16

Martabani storage jars were produced in a number of south-east Asian countries including south China, Indo-China, Burma, Siam, and later on Indonesia. The jars were then re-exported by Arab traders based at Martaban in Burma. In the 17th century this trade was taken over by the Dutch but remained almost entirely confined to south-east Asia. The rare examples which reached the Netherlands or Britain were probably brought back by Dutch sailors and are thus unlikely to be earlier than *c* 1600 (Hurst *et al* 1986, 10-11, fig 1). A number of Martabani jars are shown in a pair of similar paintings both entitled 'The Alchemist' by the Dutch artist Thomas Wijck (*c* 1616-77). These jars sit on the floor encased in a basket framework but with their distinctive lugs clearly visible (Rijksmuseum, Amsterdam; Musée de Beaux Arts, Caen). The example from Butt Road, Colchester (Fig 204.1) has a hard cream to pale brown near-stoneware fabric, with a very finely micaceous matrix with fine red and black inclusions and some coarse angular quartz grains. It has a slightly matt dark brown (alkaline?) glaze exterior which extends inside to a depth of 25 mm below the rim, ending in a straight line. The context, however, is late, as the same layer produced abundant 19th-century wares, Staffordshire etc. It may already have been antique when it

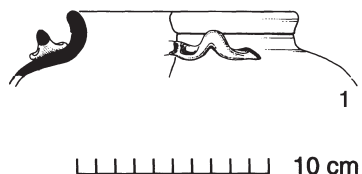

Fig 204 Martabani stoneware jar (no 1). 1:4.

was discarded, but John Hurst, who confirmed the identity of this piece, has suggested that it is just as likely to be 19th century as earlier. From the 14th century onwards, Martabani jars almost all look identical (John Hurst, pers comm). Whatever its exact date, it is an interesting addition to the list of foreign imports into Colchester and England, in view of its rarity in this country.

### Chinese porcelain (Fabric 48A)

[Fig 245.6]  
Weight: 0.490 kg  
Number of sherds: 27\*  
EVEs: 1.76\*

There is no archaeological evidence for the presence of Chinese porcelain in Colchester before the early 18th century, although it is likely that a few pieces must have been imported before this. The earliest stratified piece from the town occurred in a pit group of *c* 1730-40 (Fig 245.6; Stratified Group 22). This comes from a thin-walled dish or saucer with an unglazed foot-ring. The blue painting inside is probably a landscape with plants, and what looks like a small dog or deer but which could even be part of the elaborate hairstyle of a standing figure, but the sherd is really too small to tell. There are also traces of external painting. All told, a minimum of around twelve vessels were found on the excavations, but this figure may include one or two late pieces. The majority, however, appear to be 18th century. Four of these are small tea-bowls datable to around the second and third quarters of the 18th century (cf Jennings 1981, fig 99.1531 ff). One of these (MID CF136; found with 18th-century Creamware) has a small painted square hieroglyph on the underside almost identical to an unintelligible late Ming shop-mark illustrated by Honey (1954, 202 left). The largest 'group' of Chinese porcelain consists of three vessels from a brick latrine (LWC VF1) which contained a range of pottery and clay pipes which probably accumulated between the years *c* 1740 and 1840. These consist of a small dish or saucer with a blue-tinted glaze and blue landscape painting (cf Jennings 1981, fig 99.1543), and a small tea-bowl with a blue pagoda landscape with red and gold highlights, a central internal flower and a small central rosette mark underside. The most interesting piece from this group was a cylindrical tankard or coffee can of north European form, ribbed externally except for a central band with painted and enamelled flowers and a *café au lait* rim. This vessel was evidently prized by its owners as it had been repaired with rivets. Apart from one or two possible plate fragments, the only other form from the excavations were sherds of a poor-quality ginger jar with faint blue painting.



## Chapter 13. Miscellaneous unsourced ?imports

### Unidentified foreign wares (Fabric 95)

Weight: 0.135 kg  
Number of sherds: 10  
EVEs: 0.22

This consists mostly of body sherds which do not merit individual description. Most of them are probably post-medieval and may include burnt sherds or undecorated areas of Continental white wares.

### Mediterranean 'mercury' jars (Fabric 52)

[Fig 206]  
Weight: 0.005 kg  
Number of sherds: 1

A single sherd from the excavations (Fig 206.1) has been identified as coming from a Mediterranean 'mercury' jar (pers comm, R Thomson & A Vince, 1985). Four other complete examples have been identified in the Colchester Museum, three of which were found in Colchester and a fourth example which comes from Braintree in north central Essex. Details are given below with comments on their probable findspots kindly provided by D T-D Clarke, former curator of the museum:

Fig 206.2 (CM 242.1974). West Stockwell Street, Colchester. Found in 1964. Purchased with other pottery from H C Calver. Capacity 40 ml (to rim in all cases).

Fig 206.3 (CM 3563.17). Locality Colchester. Possibly acquired by Dr Laver during building works at St Mary's Hospital, Colchester. Capacity 35 ml.

Fig 206.4 (CM 182.1933). Probably from Colchester. Donated 1872 by Captain Codner of Dedham. Capacity 60 ml.

Fig 206.5 (CM 164.1943). Dug up on the site of West Brush Factory, West Street, Braintree. Donor Alfred Hills. Capacity 40 ml.

All of the above vessels occur in the same finely sandy, orange-pink to brick-red fabric, containing abundant rounded calcareous inclusions 0.3-0.5 mm across which have a crystalline nucleus and an amorphous outer shell. It also contains abundant fine mica (coarser in the Braintree jar), moderate coarse pellets of red iron oxide up to 4 mm across, and rare voids caused by the burning-out of plant matter. All the vessels display evidence of handling while in the wet state and all of them have an irregular covering of copper-stained green glaze finely blistered by the underlying calcareous inclusions. On Figure 206.3 and 4 the glaze is a dark, matt lichen-green and could be alkaline. On the other vessels it is transparent and lustrous and varies in tone from light to dark green, and it does not appear particularly alkaline. The glaze not only covers the outside but also the inside and the underside of the base which displays marks caused by removing the jar with a wire from a slowly revolving wheel.

Small numbers of these jars are found widely distributed across Britain. In Essex alone at least ten examples are known. These and other British examples known to the writer are listed below:

ESSEX: Harwich (pers obs, stray find submitted to CM for identification 1994), Colchester, Braintree, Cressing Temple (pers obs), Heybridge (Thomson 1986, fig 25), and Waltham Abbey (Huggins 1978, fig 16.39-40).

LONDON: Numerous examples (eg Dawson 1979, fig 222a). Museum of London, Victoria & Albert Museum.

KENT: Canterbury, at least six examples: one from North Lane (Macpherson-Grant 1978, fig 23.63); one from Saint Augustine's Abbey (Lyn Blackmore, pers comm); one from St Gregory's Priory; one from Tannery site (near Greyfriars); one from Marlowe Car

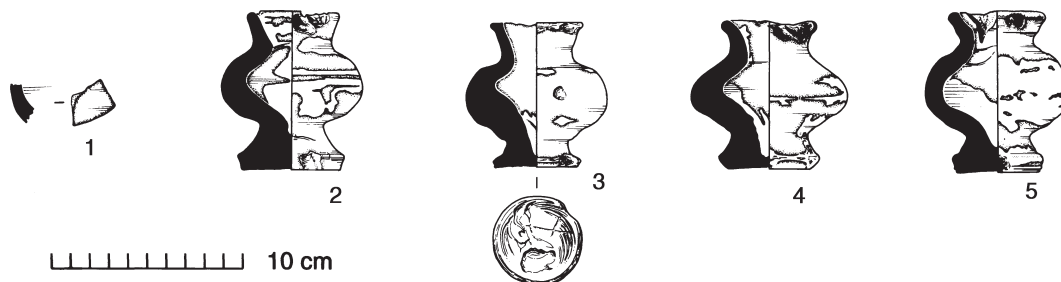

Fig 206 Miscellaneous unsourced ?imports: Mediterranean 'mercury' jars (nos 1-5) - all from Colchester except no 5 from West Street, Braintree. 1:4.

Park site; and one unprovenanced in Canterbury Museums (pers obs). Sandwich: one from Whitefriars 1993 (Dover Archaeological Group, pers obs). Hartlip: one example (Maidstone Museum).

SUSSEX: Battle Abbey (Streeten 1985, fig 34.58), Winchelsea (*ibid*, 118), and Bayham Abbey (Streeten 1983, fig 43.52).

HAMPSHIRE: Southampton: six examples (Thomson 1986, 53).

LEICESTERSHIRE: Leicester (*ibid*).

WARWICKSHIRE: Coventry (*ibid*)

SOMERSET: Acton Court: one example (Vince & Bell 1992, 107, fig 4.302).

The Heybridge vessel and a number of others (Bayham Abbey and Sandwich) occur in a different unglazed micaceous fabric though the other nine vessels from Essex occur in the glazed fabric described above. The excavated sherd (Fig 206.1, MID F1) occurred residually in a pit with 19th-century and earlier wares including Raeren stoneware, Weser and Werra wares, Martincamp, 17th-century tin-glazed wares and Border ware. However, several examples around the country occur in pre-Dissolution contexts and one Southampton example comes from a deposit of c 1500 (Thomson 1986). Because of their small capacity and very strong construction, Thomson has suggested that these small jars must have contained some very valuable substance, quite possibly mercury. Recent X-ray fluorescence of the unglazed Heybridge vessel by Justine Bayley of the Ancient Monuments Laboratory and of the Colchester and other vessels by Paul Budd, has failed to find any traces of mercury although it was not possible to examine the interior of complete vessels. A number of factors, however, could minimise the chances of mercury being detected, and as no evidence was found to suggest any alternative use for the vessels, the mercury theory cannot be discredited. The tests did, however, show significant traces of both lead and copper as components of the glaze. No other comment was made by the examiners as to the nature of the glaze.

For the unglazed jars, Thomson has suggested an Iberian origin, and on account of their alkaline glaze a Near Eastern origin has been suggested for the glazed jars (*ibid*). Spain and the Near East were the main sources of mercury known to medieval Europe. A trickle of Iberian pottery and other goods are known to have reached Colchester in the Middle Ages but no definite examples of Near Eastern pottery have

yet been identified. However, small amounts of exotic goods are listed among the taxable possessions of a few Colchester merchants as early as 1295/6 and 1301. These include ginger (?from India), senna-pods and silk, of which silk, at least, must have come from the Far East (*Rot Parl*, 1, 232, 261-2, 264). Perhaps significantly, in 1301 two Colchester merchants, William de Estorpe and William de Saaham, are recorded as having 'verdigris and quicksilver' (mercury) among their possessions (*ibid*, 263). One wonders from where, and in what form of container, mercury would have arrived at this early date.

If not mercury, then what else might these jars have contained? One conceivable possibility (Rhona Huggins, pers comm) is that they might have been used as spice mills as well as spice containers. Among the artefacts recovered from Henry VIII's flagship the Mary Rose were two three-part wooden spice-mills, the lower pedestal container being quite similar to pottery 'mercury' jars. In connection with this one should add that the rims of all the most complete 'mercury' jars from Essex are extremely abraded or worn down. Might they have formed the lower ceramic unit of an otherwise wooden spice mill?

Pottery with similar calcareous inclusions to the 'mercury' jars is found throughout the Mediterranean region. Similarities with the fabrics of late medieval *albarelli* and post-medieval marbled slipwares from Pisa, north Italy have been pointed out by Macpherson-Grant (1978). There are also similarities with certain Roman amphora fabrics thought to come from Albinia, on the coast of Tuscany. Other, more convincing similarities exist between the fabric of the 'mercury' jars and the red, calcareous-tempered fabric of 'Miletus ware'. This lead glazed, blue and white painted slipware was produced at Iznik and at other locations near Ezine in north-west Turkey, and dates to c 1450-1520. It was widely traded in the Aegean area (Atasoy & Raby 1989, 82-3). Small green glazed jars, however, are not reported among the repertoire of 'Miletus ware'.

Strangely neither the fabric nor the form of these jars is recognised in southern Spain (Alfonso Pleguezuelo, pers comm), and none is yet reported from the Low Countries. It is hoped that a wider international awareness of 'mercury' jars coupled with more detailed scientific work on 'mercury' jar fabrics and their possible contents will eventually shed more light on these enigmatic vessels.

## Chapter 14. The stratified groups

### Introduction

Twenty-two stratified groups of pottery have been selected to illustrate the range of post-Roman pottery in the town. Most of these represent pit fills though, in a few cases, the groups come from trench or ditch fills. In the case of pit groups, the fills were generally composed of one to five separate layers which normally produced abundant evidence of cross-joining sherds thus indicating a fairly rapid backfilling. In these cases, the component fills of a pit have been treated as a single context. Only in the case of the Saxo-Norman town ditch (SG 4) has it seemed worthwhile to present the component fills or layers individually.

The potential of pit groups to provide a 'snapshot' of the wares in circulation at a particular moment is fairly widely accepted and understood even if the precise moment of deposition can, at present, only be defined within fairly broad parameters. The selection of the pottery groups illustrated here was governed by a number of factors including the size and condition of the assemblage, the level of residuality present and the presence of associated datable artefacts. In general the largest, best-preserved and most closely datable groups were selected whenever possible with, ideally, at least one illustrated stratified group per century.

In practice, however, this aim could not be fully realised, for a number of reasons. As in many other medieval towns, the practice of rubbish disposal by pit-digging or otherwise has varied in Colchester over the centuries, both in intensity and possibly in distribution. The sorts of features producing pottery in the town have already been outlined in the introduction to the sites (*see above pp 1-3*). Changing patterns in rubbish disposal have resulted in an uneven sample of rubbish for any given century or half century. There is an abundance of large early medieval pits, late medieval latrines or cess-pits and 17th- and 18th-century pits, but the Saxon period, the 13th to 14th centuries and the second half of the 16th century are only poorly represented. There are probably many socio-economic reasons for these peaks and troughs in the archaeological record, too many to be explored here, but population levels, the effects of plague and changing attitudes to sanitation all undoubtedly played their part.

Despite the paucity of good stratified groups for certain periods, the best groups that could be found at the time were selected for publication here. Inevitably the quality and quantity of the material presented varies from group to group. For periods where there was an abundance of stratified groups to choose from (eg the 17th century), more than one group has sometimes been illustrated. Six of the 22 selected groups have not been fully illustrated (ie Stratified Groups 1, 3, 12, 14, 16 and 18). In some cases (Stratified Groups 1 and 3), this was because most of the significant pieces have already been published in *CAR 1*. In other cases, only the more significant items have been

illustrated (in the typology), partly to avoid the excessive replication of common forms represented in other fully illustrated groups and partly due to time and financial constraints. Most of the better-known foreign and regional imports have been illustrated to provide an immediate chronological reference point for the dating of less familiar local wares in the same stratified group. Residual post-Roman pottery is not generally illustrated except where there is some possibility that the vessels are late survivors of their class.

It is hoped that future work on post-Roman pottery in the town will eventually lead to the publication of better stratified groups for those centuries only poorly represented in the selection published below.

### Selected stratified groups

Group	Ceramic phase	Site context	Description	Date	Publication
1	1	LWC HF63	Hut 2	c 5th century	<i>CAR 1</i>
2	1	1.81 B4	Hut 3	c 7th century	<i>CAR 6</i>
3	2.1	CPS F106	pit	c 1000-1050	<i>CAR 1</i>
4	2.1-3.1	LWC NF21	ditch	c 1050-1300	<i>CAR 3</i>
5	2.3-4	1.81 HF365	cess-pit	c 1125-50	<i>CAR 6</i>
6	2.4	1.81 GF163	cess-pit	c 1175-1200	<i>CAR 6</i>
7	3.1	COC F213	cess-pit	c 1225-75	<i>CAR 6</i>
8	3.2	COC F212	cess-pit	c 1300-1325	<i>CAR 6</i>
9	4.1	LWC MF22/ F52/F53	trench	c 1382-1421	<i>CAR 1</i> & <i>CAR 3</i>
10	4.1	LWC LF33	pit	c 1400-1450	<i>CAR 3</i>
11	4	LWC BF45	pit	c 1425-75	<i>CAR 3</i>
12	4.2	LWC CF65	pit	c 1475-1525	<i>CAR 3</i>
13	4.2	SPT F14	latrine	c 1500-1525	<i>CAR 6</i>
14	4.2	1.81 EF14/F19	pit	c 1525	<i>CAR 6</i>
15	4.2	1.81 HF39/ F158	cellar	c 1525-50	<i>CAR 6</i>
16	5.1	LWC CF77/F22	pit	c 1550-1600	<i>CAR 3</i>
17	5.2	COC F61	pit	c 1625-50	<i>CAR 6</i>
18	5.2	LWC GF24	pit	c 1625-50	<i>CAR 3</i>
19	5.2	LWC VF2	pit	c 1650	<i>CAR 3</i>
20	5.2	LWC BF14	trench	c 1650	<i>CAR 3</i>
21	5.3	MID AF15	pit	c 1680-1700	<i>CAR 3</i>
22	5.3	LWC RF18	trench	c 1730-40	<i>CAR 3</i>

[In following tables, all figure references are to this volume unless stated otherwise.]

#### Group 1: (Hut 2) LWC HF63 (5th century)

This Saxon hut on Lion Walk has already been discussed and its finds illustrated (*CAR 1*, 5-6, 22-3, fig 5.5-7 & 9). Two other pots (*ibid*, fig 5.8 & 12) are from post-Saxon contexts nearby. They probably derive from the hut but are

excluded from the quantification below. The hut comprises the earliest post-Roman assemblage from the town and has been dated by the excavator to c 400-50 largely on the basis of typological comparisons with pottery from the latest levels at Feddersen Wierde. Pottery statistics are included here for the sake of completeness.

Fabric	EVEs	Weight (g)	Sherds	Figs
1	-	40	5	CAR 1, fig 5.6
97	0.52	800	64	<i>ibid</i> , fig 5.5, 7, 9
<b>TOTAL</b>	<b>0.52</b>	<b>840</b>	<b>69</b>	

Fabric 97 comprises 93% (by sherds) of the assemblage; Fabric 1C the remainder. Fabric variants indicate the presence of ten vessels at the very least. The fabrics can be related to some degree with those defined by Ailsa Mainman at Heybridge, Essex which have a general application over much of the county (Drury & Wickenden 1982, 13-15). The ten fabric variants are as follows:

Fabric 1 vegetable-tempered ware: three variants present roughly corresponding to Heybridge fabric 1C —

- i. Fine sandy with rare larger quartz grits. Moderate vegetable temper including some clear grass seed impressions.
- ii. Fine, relatively sand-free, with low-moderate vegetable temper. Moderate fine calcareous inclusions — possibly crushed shell. Thin-walled (minimum 4 mm).
- iii. Sandy with some quite coarse angular quartz grits (max 1.2 mm across) and rare angular flint. Vegetable temper mostly superficial. Moderate fine calcareous inclusions. Includes bossed ?biconical bowl (CAR 1, fig 5.6).

Fabric 97 Sandy 'brickearth': seven variants present —

- i. Fine with moderate fine sand and rare coarse quartz grits. Thin-walled vessels (minimum 3 mm). Used for biconical bowls (*ibid*, fig 5.5). As Heybridge fabric 2.
- ii. Uniformly sandy, densely-packed quartz grains (0.25-0.5 mm). Thicker vessels. Internal and external burnishing. As Heybridge fabric 3 but sandier.
- iii. Coarsely quartz-gritted. Densely-packed sub-angular grains (0.5-1.5 mm) with rarer quartz, flint and ?calcite grits (maximum 3 mm across). Used for dish (*ibid*, fig 5.7). As Heybridge fabric 3 but coarser.
- iv. Almost sand-free with moderate fine calcareous inclusions — chalk fossils or oolite. Thick-walled vessels burnished both sides. Related to Heybridge fabric 4C.
- v. Almost sand-free but for a few coarse grits and moderate-coarse shell inclusions (?fossil), plus clay pellets and iron oxide. Related to Heybridge fabric 4C.
- vi. Almost sand-free with a few coarse grits plus medium-coarse calcareous and shelly inclusions plus flint grits and clay pellets. Related to Heybridge fabric 4C.
- vii. Sandy with moderate fine ?fossil shell and chalk fossil or oolite. Thick-walled vessels burnished both sides. Includes large cooking/storage jar (*ibid*, fig 5.9). Related to Heybridge fabric 4C.

The sort of round-bottomed bowls or *Schalenuren* represented at Colchester, which date the hut, already occur in the area of the Elbe in Germany in the late 4th and early 5th centuries (Hurst 1976, 292). Their occurrence in England has sometimes been taken to imply the presence of Germanic mercenaries, but at Mucking, one of the main sites where this claim used to be made (*ibid*), the suggestion that these bowls point to 4th-century Germanic presence has been refuted (Hamerow 1993, 57).

Philip Crummy prefers to see Hut 2 as post-dating the start of the main Saxon migration of c 440-50 rather than dating it to c 400-450 (CAR 1, 22-3). However, the five Saxon huts published from Heybridge, Essex show a range of fabrics and forms remarkably similar to those from Hut 2 and which are dated by the excavators to the the first half, and probably the first quarter, of the 5th century (Drury & Wickenden 1982, 18).

### Group 2: (Hut 3) 1.81 BF4 (7th century)

[Fig 207]

This Saxon hut on the Culver Street site has been published in CAR 6 (pp 118-20). The small finds are published in CAR 5 and the pottery is published below. The non-ceramic dating evidence is in the form of a copper-alloy ring-headed pin of probable 7th-century date (*ibid*, fig 2.3) and a decorated antler comb (*ibid*, 22-3, fig 25.1850) of 6th- or 7th-century date which lay on the surface of the hut floor. A ?late Roman penannular brooch fragment from the lowest layer was probably residual (CAR 6, fig 5.1, 34).

All the pottery recovered is vegetable-tempered ware (Fabric 1). There were three layers infilling the hut; these in stratigraphic order were:

Layer	EVEs	Weight (g)	Sherds	Figs
L6	1.47	1,845	104	
L12	0.51	815	87	207.2-4
L13	0.96	540	43	207.1
<b>TOTAL</b>	<b>2.94</b>	<b>3,200</b>	<b>234</b>	

Catherine Hill comments: 'The joins between sherds indicate that L6 (the uppermost layer) and L12 are both part of what is essentially the same deposit, interpreted reasonably by the excavator as backfill or demolition after the hut had gone out of use. This pottery therefore strictly speaking dates not the use but the disuse of the structure. The complete reassembled pot (Fig 207.1) comes from L13, the level interpreted as the occupation layer, and might therefore be seen as contemporary with the use of the hut. Altogether at least five pots are represented in the assemblages from all contexts relating to the hut. This is a minimum number and several more vessels probably exist, but it is still not a very large number although the total of 234 sherds is considerably more than the number found in at least one of the other Saxon huts in Colchester (Hut 1, CAR 1, 1-5).

Two shapes seem to occur, although with such irregular hand-made vessels it is difficult to be sure how representative of the whole pot small sherds can be. There are, firstly, large globular or sub-globular pots with everted rims above cylindrical or slightly outwards-splayed necks (Fig 207.4). The second shape is narrower but with a proportionately wider mouth; these smaller baggy pots are best represented by Figure 207.1. The burnt deposit on the inside of this pot may be the remains of food, and this, with other patches of burning, suggests use in cooking rather than, or as well as, storage. The shapes of the pots are not very helpful, except in so far as the absence of any identifiably early shapes confirms the indication given by the lack of decorated pottery that the assemblage is likely to be later than 5th century. Plain sub-globular or baggy

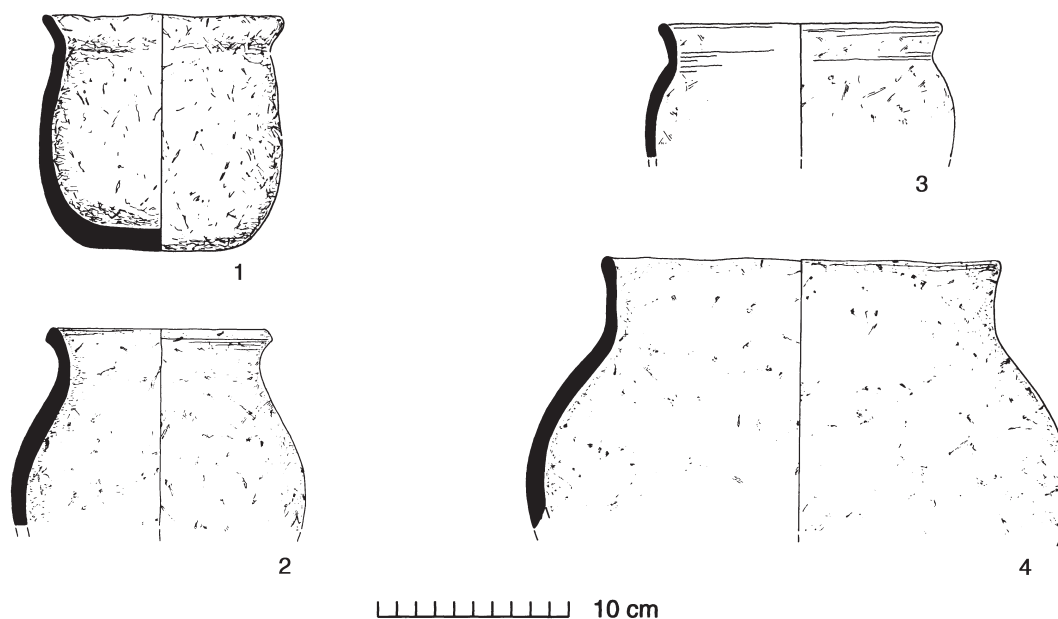

Fig 207 Stratified Group 2: 1:81 BF4 (Saxon Hut 3), 7th century (nos 1-4). 1:4. [Pages 310-11]

vessels like these seem to occur relatively late in funerary contexts but may have a very long life in domestic situations. Combining the evidence from pottery, pin and comb, a 7th-century date might be suggested for the Culver Street hut, but that is only the middle of a wider possible date range.' ■

Pottery statistics from the broadly contemporary 6th-/7th-century hut on Lion Walk are given below (minus some post-medieval contamination).

#### Hut 1 (6th/7th century)

Fabric	EVEs	Weight (g)	Sherds	Figs
97	0.20	55	10	
1	0.16	655	46	CAR 1, fig 5.1
<b>TOTAL</b>	<b>0.36</b>	<b>710</b>	<b>56</b>	

#### Group 3: CPS F106 (c 1000-1050)

##### Pit to rear of the Cups Hotel, High Street

[Not illustrated in this volume. Previously published in CAR 1, fig 30.]

Fabric	EVEs	Weight (g)	Sherds	Figs
13	-	50	7	20.1
12D	-	10	1	
12C	-	25	2	
9	1.10	370	63	CAR 1, fig 32.3-11
1	-	35	4	stamped sherd <i>ibid</i> , fig 21.1
<b>TOTAL</b>	<b>1.10</b>	<b>490</b>	<b>77</b>	

*Stratigraphy.* F106 cut another pit F95 which contained two vegetable-tempered sherds (Fabric 1) and one of Thetford-type ware (Fabric 9). The dating of this group rests mainly on the high proportion of Thetford-type ware relative to other fabrics. For the dating of Thetford-type ware in Colchester, see pages 31-2 where this group is further considered.

#### Group 4: LWC NF21 (c 1050-1300)

[Figs 208-213]

##### Saxo-Norman town ditch (Fig 208)

###### Dating evidence

This rests entirely on the ceramic evidence and the internal stratigraphic sequence (see p 41).

The ditch apparently contained a dumped layer at the bottom (F2101 here; see CAR 1, 33), and thereafter a gradual accumulation gives various pottery horizons. Each sherd or group of sherds was assigned a separate finds number and plotted in the original section drawing. This accumulation, excavated as 'spits', has arbitrarily been divided into four horizons above the primary fill for the purposes of understanding the changing ceramic sequence. Wherever possible, however, the horizons shown in Figure 208 were based on actual tip lines visible in the detailed section drawing published in CAR 3 (Sx 55, sheet 6a).

##### F2101 (c 1050-1075)

Fabric	EVEs	Weight (g)	Sherds	Figs
13	2.35	3,820	230	209.1-14
12C	0.08	30	1	209.15
<b>TOTAL</b>	<b>2.43</b>	<b>3,850</b>	<b>231</b>	

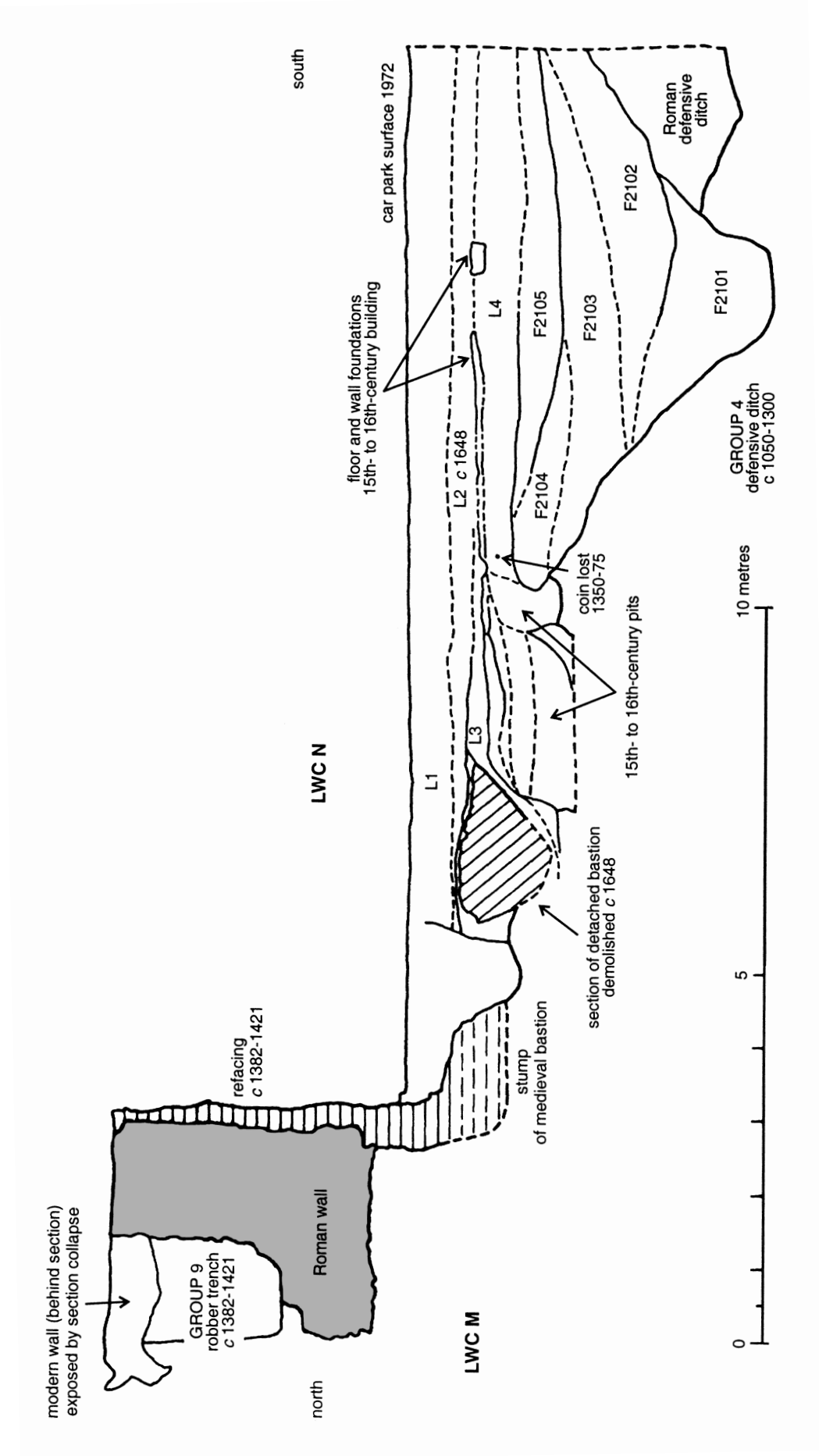

Fig 208 Simplified section through town ditch at Lion Walk showing positions of Stratified Groups 4 (c 1050-1300) and 9 (c 1382-1421). [Pages 311-16, 322, 324-5]

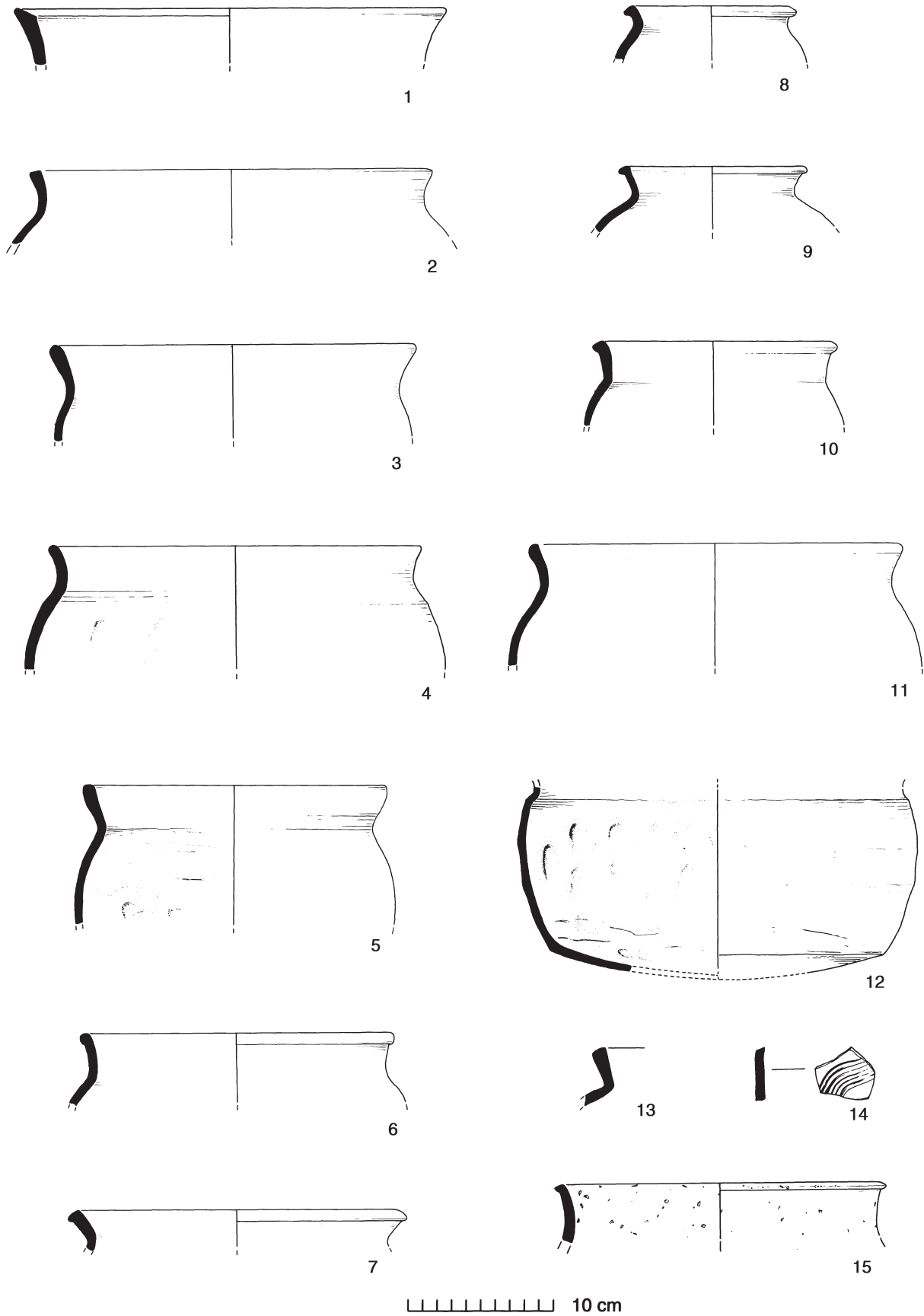

Fig 209 Stratified Group 4: LWC NF2101, c 1050-75 (nos 1-15). 1:4. [Pages 311, 315-16]

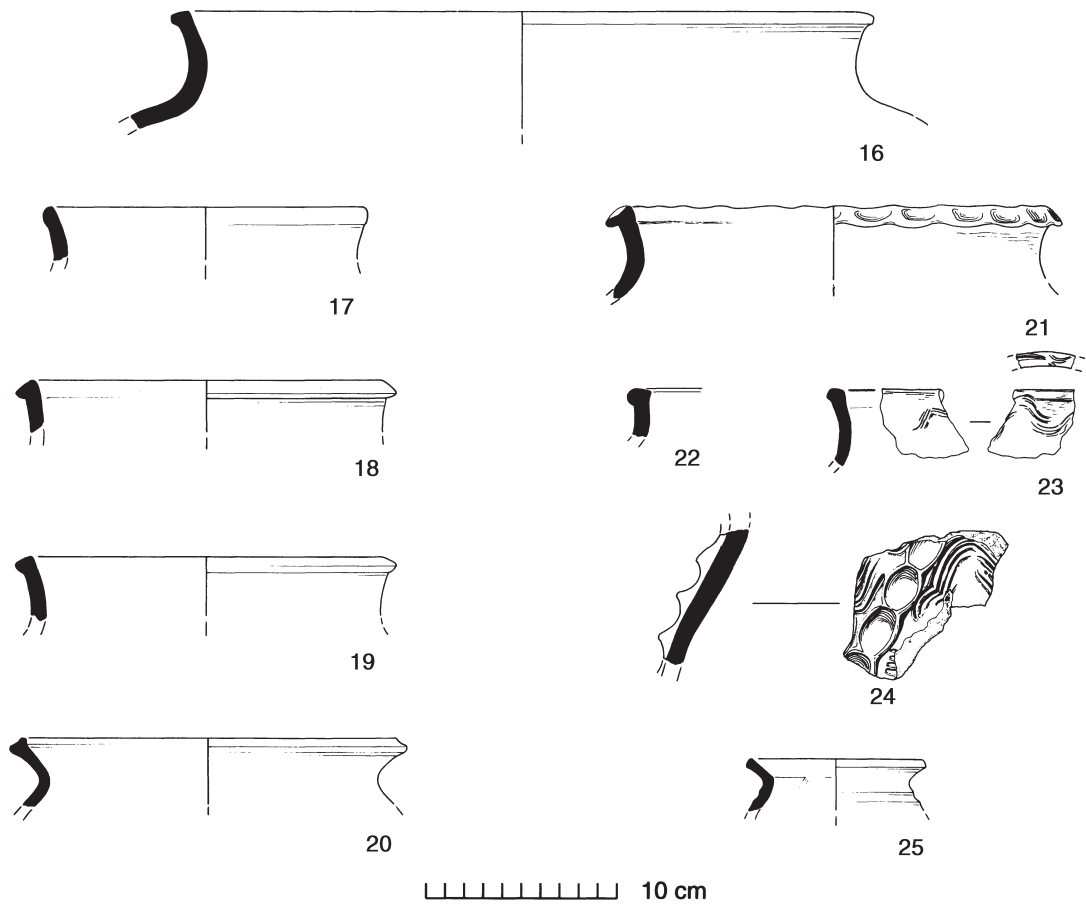

Fig 210 Stratified Group 4: LWC NF2102, c 1075-1150 (nos 16-25). 1:4. [Pages 311, 315-16]

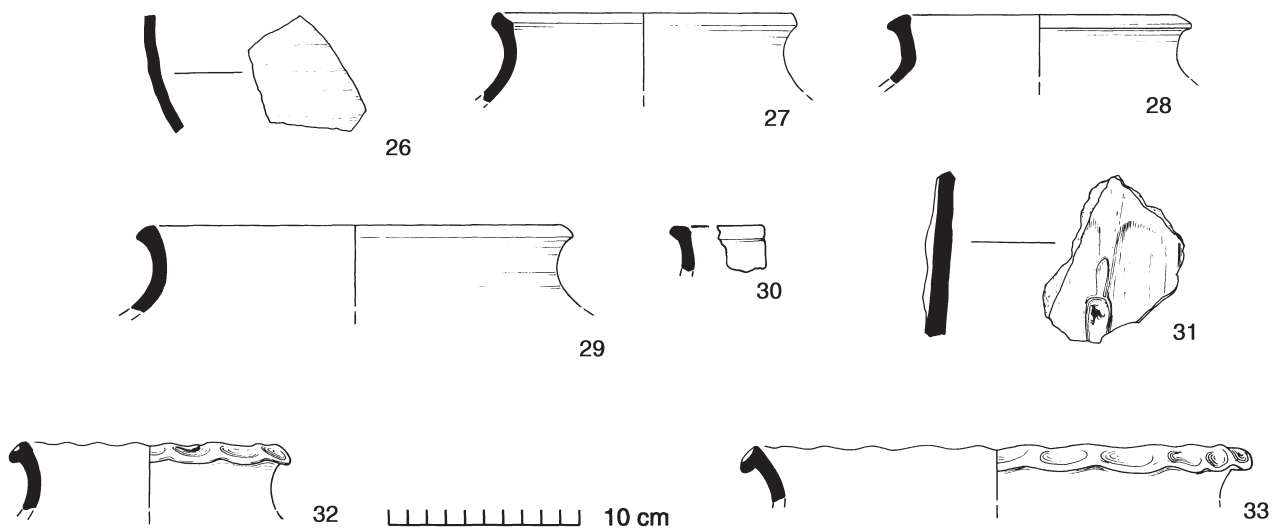
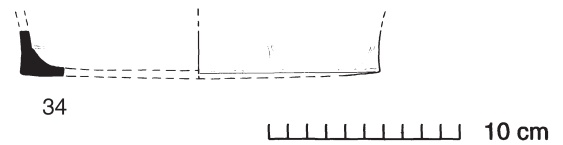

Fig 211 Stratified Group 4: LWC NF2103, c 1150-1200 (nos 26-33). 1:4. [Pages 311, 315-16]



**F2102** (c 1075-1150)

Fabric	EVEs	Weight (g)	Sherds	Figs
13	0.48	630	33	210.16-24
13S	-	280	30	
13T	-	20	1	
9	0.20	35	4	210.25
<b>TOTAL</b>	<b>0.68</b>	<b>965</b>	<b>68</b>	



**F2103** (c 1150-1200)

98	-	35	2	(?Midlands)
21A	-	15	1	(jug — see p 112)
20	-	5	1	
17	-	30	2	211.26
13	0.52	490	35	211.27-33
13S	-	90	8	
13T	-	30	3	
12B	-	10	1	
12C	-	15	1	
<b>TOTAL</b>	<b>0.52</b>	<b>720</b>	<b>54</b>	

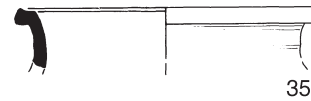

Fig 212 Stratified Group 4: LWC NF2104, c 1200-25 (nos 34-35). 1:4. [Pages 311, 315-16]

**F2104** (c 1200-1225)

22	-	30	1	212.34 (Hedingham)
20	-	45	4	
13	-	20	1	
13S	-	5	1	
13T	0.11	20	1	212.35
12B	-	10	1	
<b>TOTAL</b>	<b>0.11</b>	<b>130</b>	<b>9</b>	

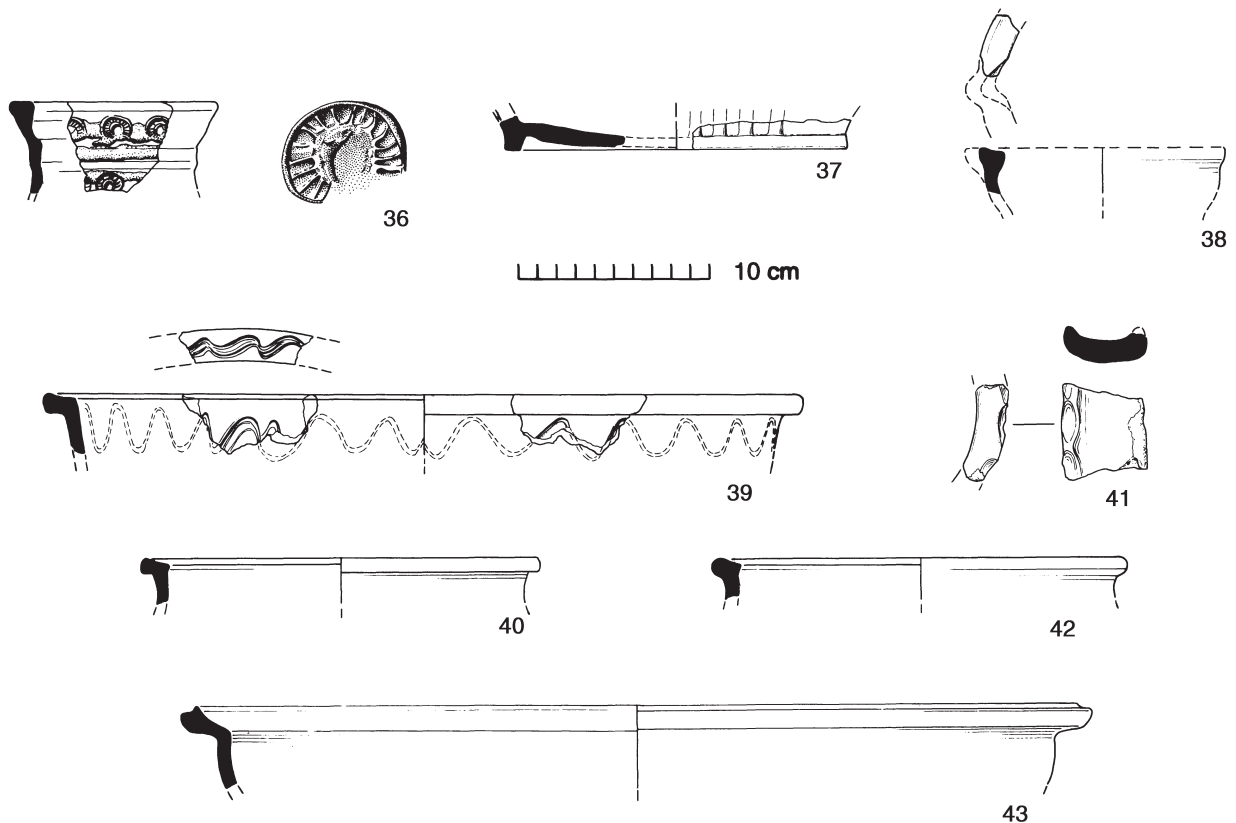

Fig 213 Stratified Group 4: LWC NF2105, c 1225-1300 (nos 36-43). 1:4, stamp detail on no 36 at 1:1. [Pages 311, 315-16]

**F2105** (c 1225-1300)

Fabric	EVEs	Weight (g)	Sherds	Figs
36	-	60	2	213.37 (London-type jug)
22	0.16	60	3	213.36 (Hedingham jug)
20	0.18	355	23	213.40-3
13	0.05	80	6	213.39 (?bowl/curfew, sooted internally)
13T	-	95	8	213.38 (jug)
<b>TOTAL</b>	<b>0.39</b>	<b>650</b>	<b>42</b>	
<b>SUB-TOTAL</b>	<b>4.13</b>	<b>6,315</b>	<b>404</b>	

**Group 5: 1.81 HF365** (c 1125-1150)

[Fig 214-15]

**Large sub-circular pit, probably a cess-pit**  
(CAR 6, 123-4, fig 3.72, sheet 3b)

Dating evidence: pottery only

Not part of any real stratigraphical sequence, the pit is sealed by clearance levels and cut by an early medieval robber trench 1.81 HF386. Cuts through a Roman tessellated pavement. The Fabric 13 vessels include some pieces (Fig 214.4) with a similar simple form and soft fabric to those from Group 4 (LWC NF2101), c 1050-1075, but also more developed and decorated forms foreshadowing the products of the Middleborough kilns c 1175-1225. The conical bowl (Fig 215.14) and the spouted pitcher with combed decoration (Fig 215.17) are particularly well paralleled by the kiln products. In general, however, the fabric and simple rims displayed by the cooking pots in this group point to an early to mid 12th-century date. A single sherd of Hedingham ware (Fig 214.1) is of critical importance to the dating of this group, since the earliest stratified pieces of this ware in Colchester are believed to date to c 1140/50 (see p 84). The sherd from this group is decorated with an 'X' frieze in thickly smeared red slip typical of Hedingham ware early rounded jugs (see Fig 216.1, Group 6, below). This sherd, then, may suggest a date somewhat closer to the mid 12th century rather than earlier.

The good state of preservation of the vessels in this group, their general similarity, the unusually high number of possible lamps (Fig 215.13-16), and the presence of a curfew (Fig 215.18) all point to deposition from a nearby dwelling.

Fabric	EVEs	Weight (g)	Sherds	Figs
22	-	10	1	214.1
13S	0.39	970	16	215.12
13	6.71	12,610	322	214.2-11 & 215.13-18
12C	-	300	2	215.19 (mostly from HL3)
<b>TOTAL</b>	<b>7.10</b>	<b>13,890</b>	<b>341</b>	

**Group 6: 1.81 GF163** (c 1175-1200)

[Figs 216-17]

Sub-square cess-pit (CAR 6, fig 3.72, sheet 3b). Part of a complex of intercutting square and oval cess-pits pits on this site which were densely packed with layers of pottery. Analysis of these layers failed to reveal any significant morphological/chronological changes within the pottery. Environmental samples from the pits yielded goat droppings, and significant quantities of herring and cod bones (some with evidence of filleting) with lesser amounts of eel and other species. Oyster and mussel shell were also quite common (CAR 6, 273-87). The relatively high number of bowls from these pits is notable, as is the fact that some were of the tubular-handled variety (eg Fig 217.23-24). This suggests these forms could have a particular association with the cooking and preparation of fish (ie as frying-pans).

Dating evidence. As the only coin (Edward the Confessor) was residual, dating evidence depends on the pottery and a good stratigraphical sequence. On the basis of parallels with London-type ware, the Hedingham ware early rounded jug (Fig 216.1) may be dated to c 1175-1200 (Pearce *et al* 1985, fig 9 & 14.18). This form, however, was probably already current but rare c 1140 (*ibid*, 19). Cooking pot parallels with Groups 4 and 5 might have suggested a slightly earlier, perhaps mid 12th-century, date for this group as a whole, but the squared rim of Figure 217.17 signals the appearance of late 12th- or early 13th-century cooking pot forms. A single sherd from a London-type fine-ware jug, probably 13th century, was found in the latest pit in this complex (GF450).

Fabric	EVEs	Weight (g)	Sherds	Figs
22	-	70	1	216.1
13	6.53	9,670	853	216.2-5, 8-9, 11, 217.16, 19-22, 24-27
13S	10.11	12,890	938	216.6-7, 10, 12-14, 217.15, 23
13T	0.17	150	1	217.17
12A	-	110	3	
<b>TOTAL</b>	<b>16.81</b>	<b>22,890</b>	<b>1,796</b>	

**Group 7: COC F213** (c 1225-75 or possibly c 1250)

[Fig 218]

Large sub-rectangular pit, probably a cess-pit (CAR 6, fig 13.113, COC Period 7). One of several 13th-century pits on this site cutting the 12th-century robber trenches, and ultimately sealed by cultivation layers containing sherds of polychrome Colchester-type ware imitating Mill Green polychrome ware (ie c 1290-1325). Dating evidence is mostly derived from the pottery itself and good stratigraphic relations. It is cut or sealed by F219 and cuts F235 (both Period 3.1) and sealed by cultivation layers L118 and L49 (both Period 3.2; see site summary pp 8-9).

The pottery date hangs partly on the absence of later fabric types such as Mill Green ware (c 1250/75-1350). The greyware (Fabric 20) cooking pot rims are transitional in character between the squared type with an upright neck, characteristic of the early to mid 13th century, and the neckless type typical of the mid/late 13th century onwards. Here,

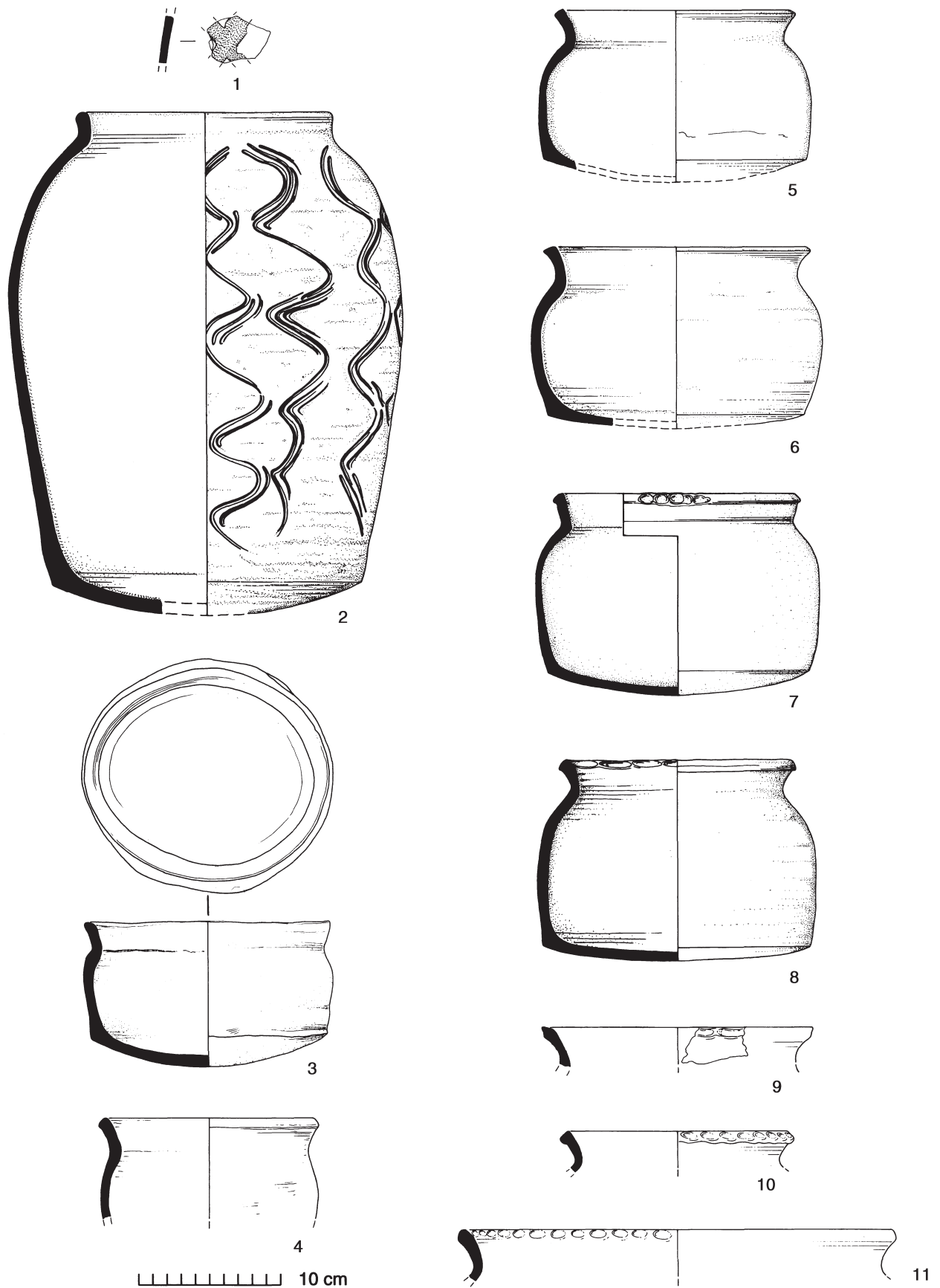

Fig 214 Stratified Group 5: 1.81 HF365, c 1125-50 (nos 1-11). 1:4. [Pages 316-18]

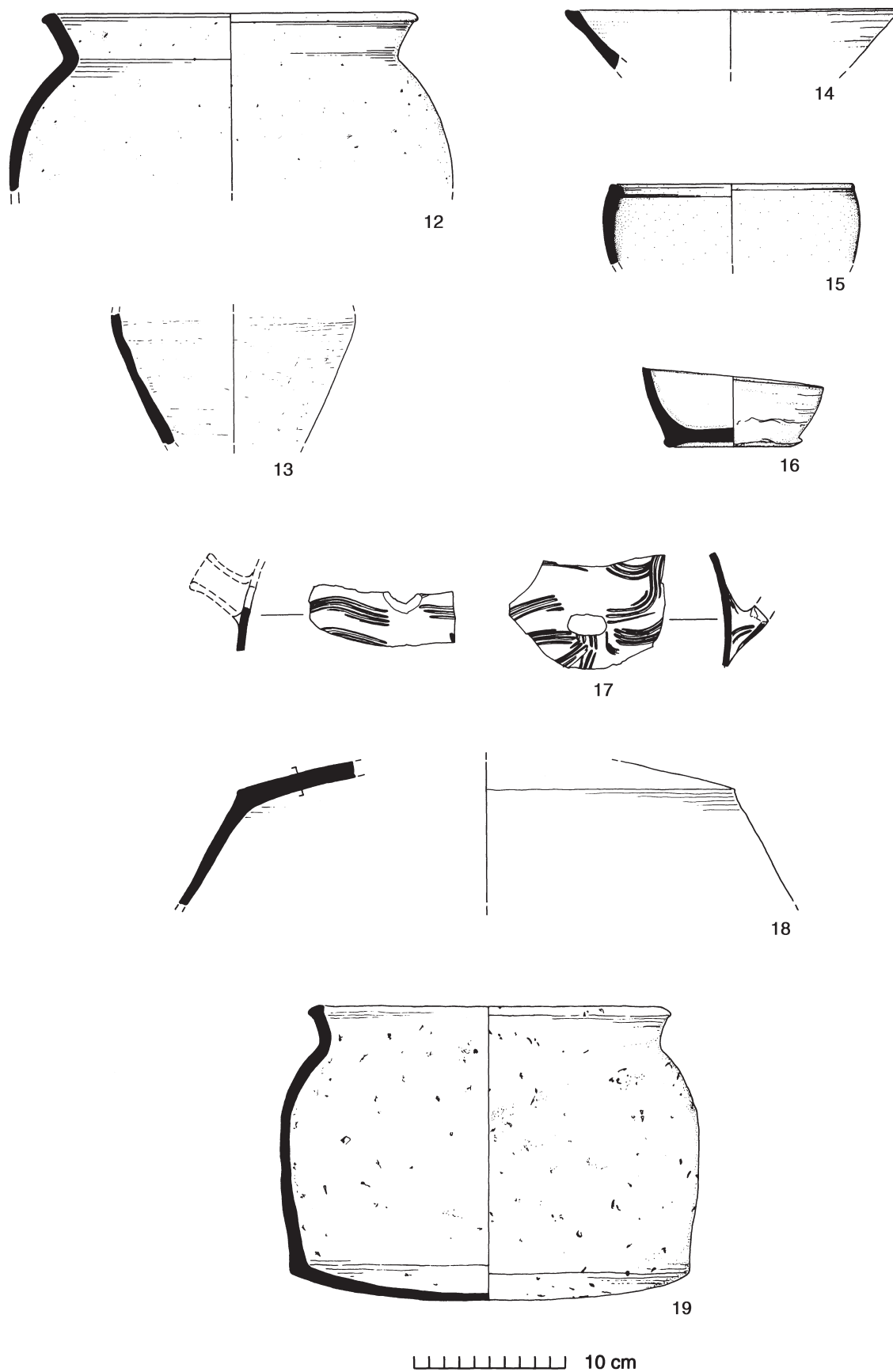

Fig 215 Stratified Group 5: 1.81 HF365, c 1125-50 (nos 12-19). 1:4. [Pages 316-18]

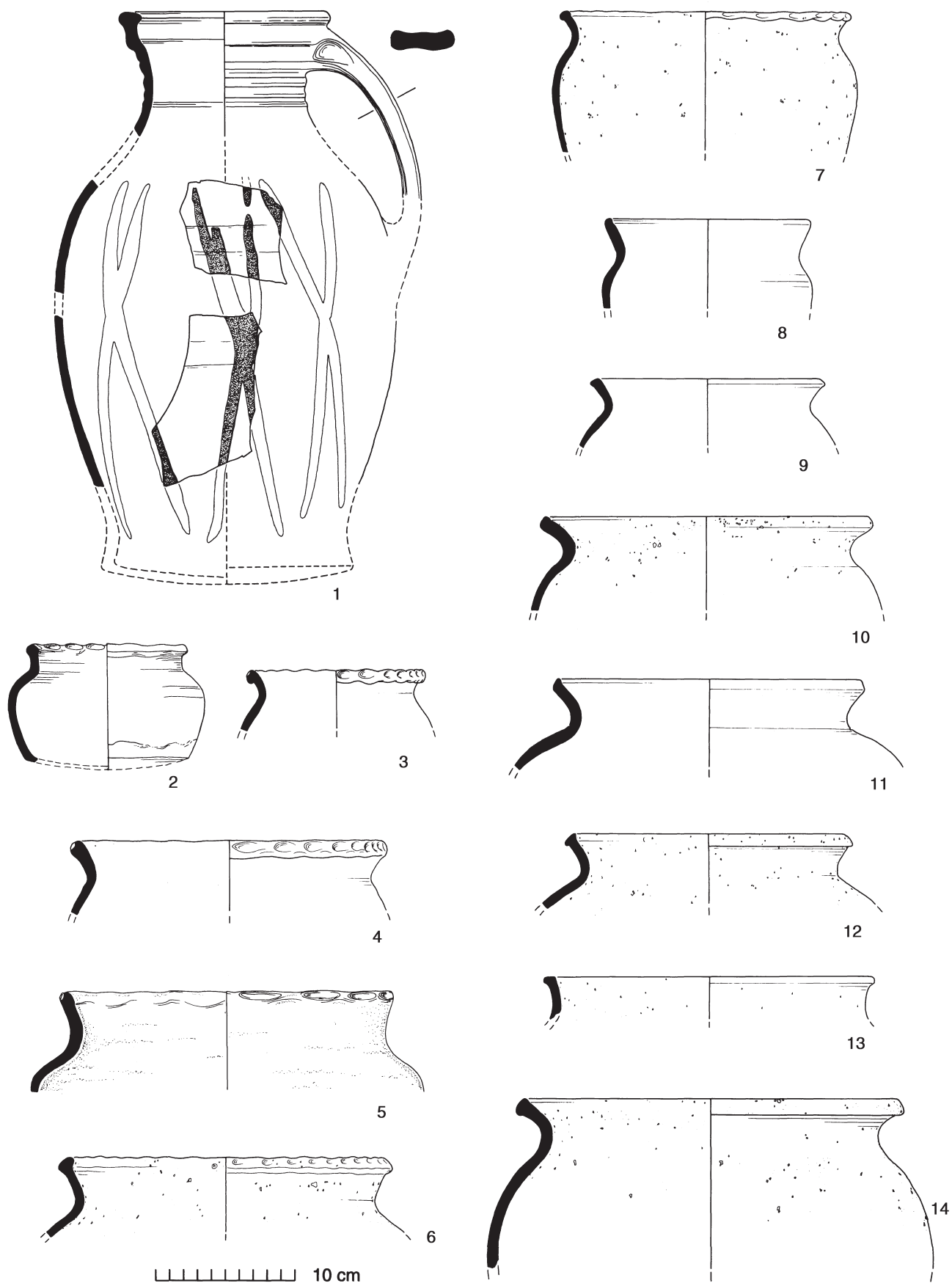

Fig 216 Stratified Group 6: 1.81 GF163, c 1175-1200 (nos 1-14). 1:4. [Pages 316, 319-20]

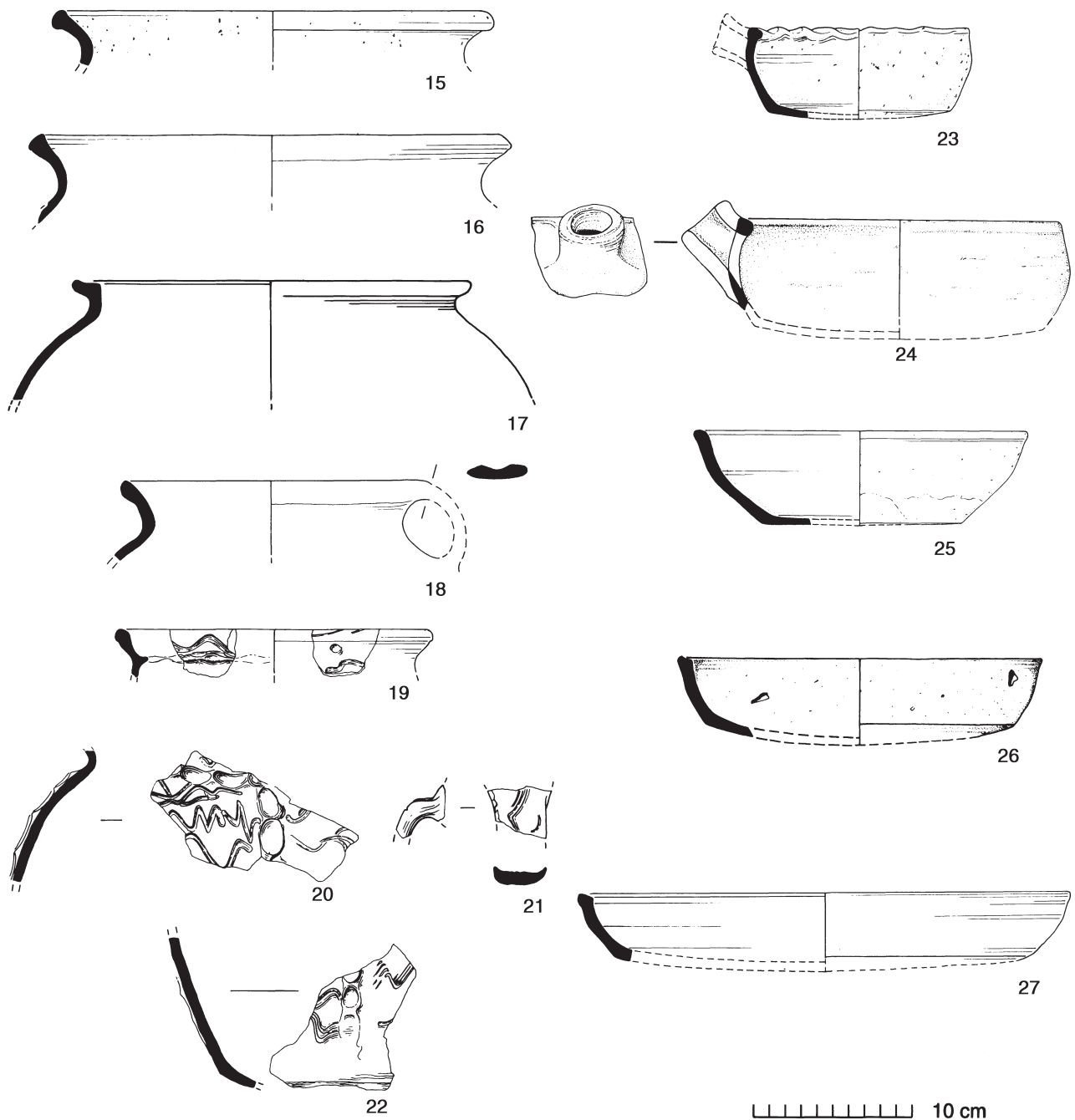

Fig 217 Stratified Group 6: 1.81 GF163, c 1175-1200 (nos 15-27). 1:4. [Pages 316, 319-20]

also, we have an early 13th-century greyware jug with a hand-made body (Fig 218.8) alongside a fully wheel-thrown jug with a correspondingly late inturned rim (Fig 218.7). The absence of true oxidised Colchester-type ware (Fabric 21A) from this group is curious. However, the transitional or hybrid character of much of the early medieval sandy ware here (Fabric 13; presumably residual?) should be noted. Apart from a few sherds with typical Fabric 13 rims and decoration, most of it cannot readily be distinguished from accidentally oxidised greywares (Fabric 20) or underfired early Colchester-type ware,

although none of it is glazed. The jug profile Figure 218.8 falls into this category but the form should identify it as a greyware. Sherds of glazed Colchester-type ware do, however, occur in other cess-pits in this phase (eg decorated jug from F146, Fig 82.60).

Fine wares in the group are still predominantly early 13th-century types. The Rouen-style baluster jug in London-type ware (Fig 218.1) is a type that died out c 1240 (Pearce *et al* 1985, fig 9). The Hedingham jug (Fig 218.2) is probably of early rounded form but bears traces of applied decoration

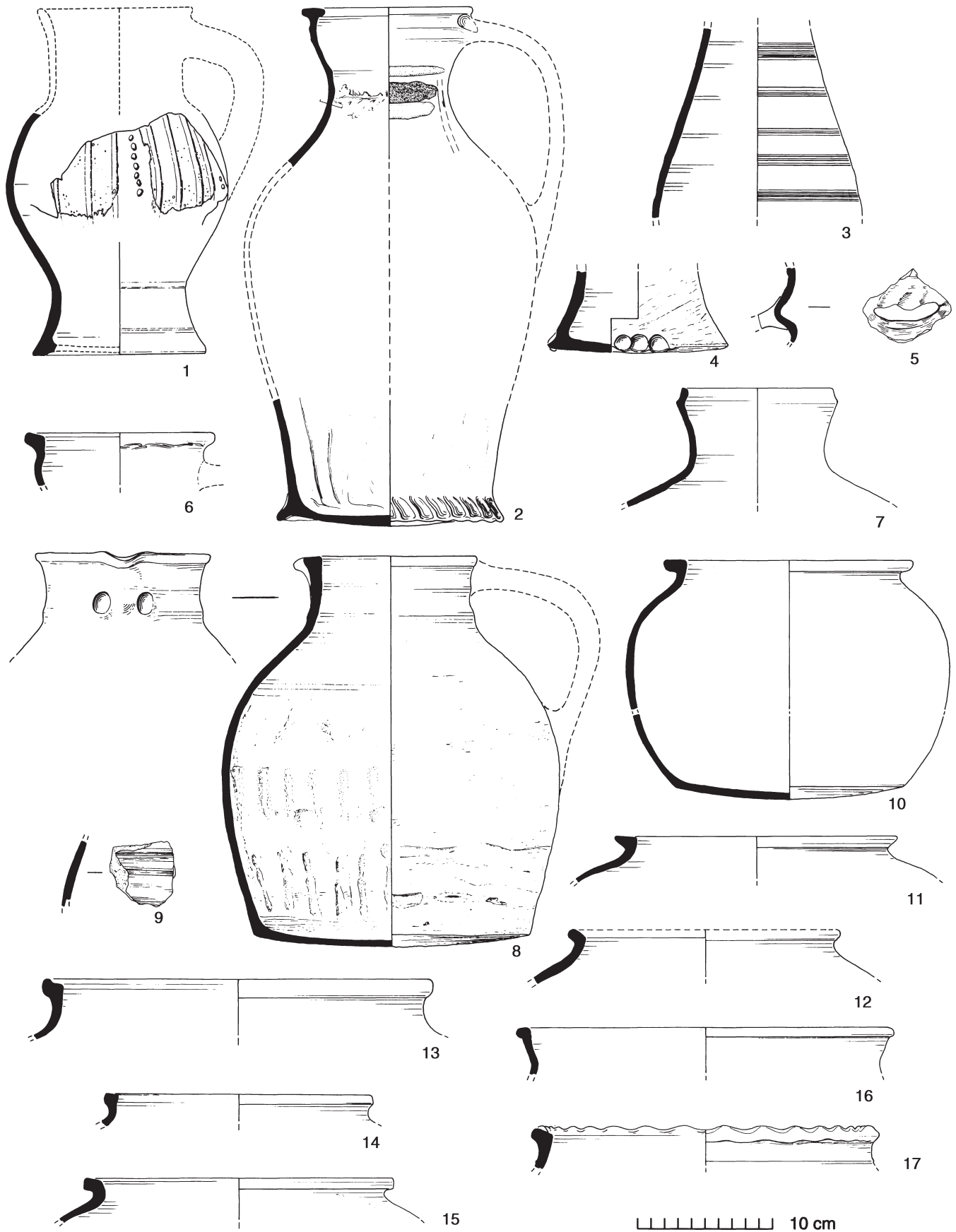

Fig 218 Stratified Group 7: COC F213, c 1225-75 (nos 1-17). 1:4. [Pages 316, 320, 322]

possibly in imitation of the London Rouen-style. There is also part of a jug handle (Fig 218.5) in a green glazed buff fabric, probably a Yorkshire product (John Hurst, pers comm). Two other glazed jugs (Fig 218.3-4) occur in a sandy grey-brown fabric; they probably come from an as yet unidentified Essex or Suffolk source and have been given the temporary label 'Long Wyre Street' ware (Fabric 98W) after the find-site.

Fabric	EVEs	Weight (g)	Sherds	Figs
98W	-	160	6	218.3-4
98	-	20	2	
36	-	410	16	218.1
24X	-	40	1	218.5
22	0.26	470	9	218.2
20	1.85	2,905	156	218.6-15
13S	0.07	60	4	218.16
13	0.10	695	43	218.17
9	-	35	4	
<b>TOTAL</b>	<b>2.28</b>	<b>4,795</b>	<b>241</b>	

### Group 8: COC F212 (c 1300-1325)

[Fig 219]

Large sub-square cess-pit (CAR 6, fig 13.113, COC Period 8). The cultivation layers sealing Stratified Group 7 (above) were cut in turn by a second episode of cess-pit digging associated with a new building (Building 149) on the frontage of Long Wyre Street (see p 9). This unlined steep-sided pit (2.2 m deep) belongs to this episode. The main dating evidence in this site period depends on the presence of Colchester-type copies of Mill Green ware polychrome baluster jugs which should date to c 1290-1325, including the polychrome sherds shown here (Fig 219.3) and the non-polychrome baluster form (Fig 219.2; and see p 127). Sherds of Colchester-type polychrome also occurred in the cultivation layer cut by this pit, but true Mill Green ware was absent from this site. Apart from this, the blocked neckless Fabric 20 cooking pots are consistent with a later 13th- or 14th-century date.

Fabric	EVEs	Weight (g)	Sherds	Figs
27	-	25	1	(Saintonge green monochrome)
22	-	10	2	(strip jugs)
21A	0.22	1,230	8	219.1-3
20	0.22	900	60	219.4-8
13S	-	150	1	
9	-	35	1	
<b>TOTAL</b>	<b>0.44</b>	<b>2,350</b>	<b>73</b>	

### Group 9: LWC MF22/F52/F53 (c 1382-1421)

[Figs 220-21]

#### Robber trench (Fig 208)

The town wall was heavily refurbished during this period, partly in response to the Peasants' Revolt of 1381 with which Colchester had been intimately connected, and partly as a response to the fear of French invasion. John Ball, one

of the leaders of the revolt, was a rector of the nearby village of Peldon and owned property in the Stockwell Streets area of Colchester. The other leader, Wat Tyler, may have been a native of Colchester but the evidence for this is inconclusive (VCHE, 9, 24-6; Bird 1987).

On July 2nd 1381, Richard II came in person to the town to mete out punishments and to personally initiate the renovation and refortification of the ancient town wall. From this year until 1421, but particularly in Richard's reign (1377-99), the Court Rolls and Oath Book of Colchester record the progress of these undertakings which were a heavy financial burden on the town (Hull 1958, 15-16; VCHE, 9). Archaeological investigation of the wall due south of Lion Walk has identified portions of this medieval repair (CAR 3, 84).

The pottery group discussed here came from an unusually deep trench dug to remove building materials from the inner face of the wall — apparently to provide for the building of a new bastion on the opposite outer face of the wall. As strict regulations normally protected the wall from even minor encroachment and interference, the thoroughness and scale of this robber trench suggests an official undertaking which therefore associates the trench and its fill very closely with the 1382-1421 refurbishment. The pottery itself is furthermore entirely consistent with a date of c 1400 (Siegburg and Langerwehe stonewares, Cheam biconical jugs, etc). The integrity of the group is also enhanced by the unusually low percentage of obviously residual material (Fabrics 20 and 22). No other finds from the trench produced significant dating evidence. This group, although rather fragmentary, is of key importance therefore as one of the very few deposits of medieval pottery in the town closely linked to a historical event.

#### Lower fill, F53:

Fabric	EVEs	Weight (g)	Sherds	Figs
21A	0.81	2,700	115	220.8, 10-11, 13, 17, 21, 23-26, 221.28-29, 33, 35, 37-38
21C	-	30	3	220.18-20
45A	-	125	5	220.5
45B	-	45	3	220.1-2, 4
<b>TOTAL</b>	<b>1.06</b>	<b>2,900</b>	<b>126</b>	

#### 'Middle' fill, F52 (slot parallel to wall)

Fabric	EVEs	Weight (g)	Sherds	Figs
21A	-	305	17	220.12, 221.31, 36

#### Upper fill, F22

Fabric	EVEs	Weight (g)	Sherds	Figs
98	-	40	2	
45A	-	45	3	220.6
45B	0.05	10	1	220.3
31	-	55	9	
23E	-	25	1	220.7
22	0.12	15	2	
21A	0.37	760	43	220.9, 14-16, 22, 221.27, 30, 34
20	-	115	1	
<b>TOTAL</b>	<b>0.54</b>	<b>1,065</b>	<b>62</b>	
<b>SUB-TOTAL</b>	<b>1.6</b>	<b>4,270</b>	<b>205</b>	



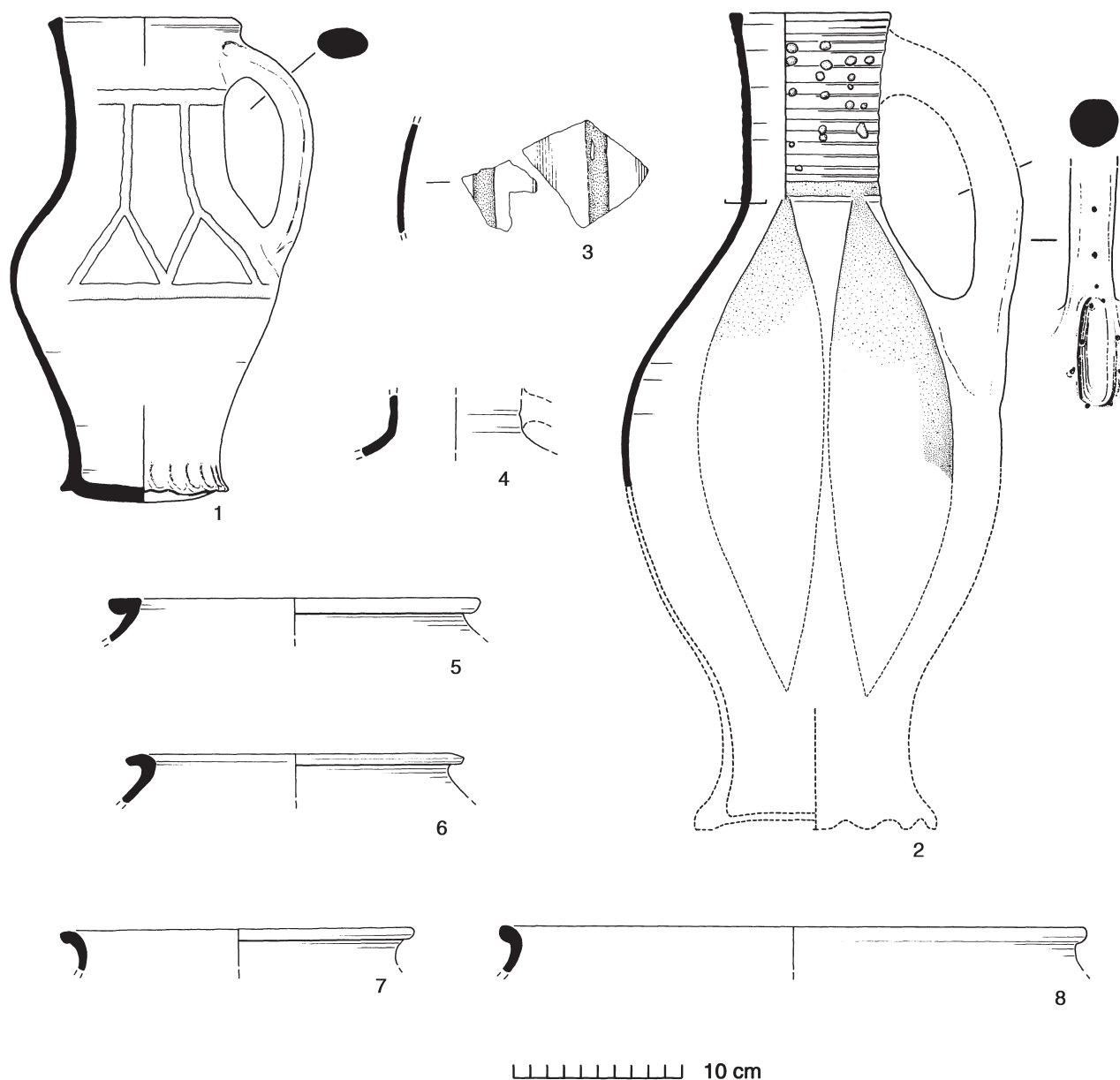

Fig 219 Stratified Group 8: COC F212, c 1300-25 (nos 1-8). 1:4. [Pages 322-3]

### Group 10: LWC LF33 (c 1400-50)

[Figs 222-4]

Large sub-rectangular clay-lined pit with a pair of large post-holes at its periphery, possibly for industrial purposes — eg ?fulling, tanning etc (*CAR 3*, fig 61, sheet 2b; NB erroneously indicated as pit LF142). Cuts early medieval robber trench LF57. Stratigraphically it post-dates the Period 3.2 (13th/14th century) lime kilns and predates Building 31 (a Charles I almshouse). It is also cut by F34 which contained material of c 1475-1550. Its close typological resemblance to Group 9 is also material. Other finds include a piece of white-slipped Flemish floor-tile and unidentifiable vessel glass. The latest recognisable piece in the group is a small sherd of Raeren stoneware (normally c 1475+), but it could be an overfired sherd of Langerwehe stoneware.

Fabric	EVEs	Weight (g)	Sherds	Figs
98	-	10	1	
46B	-	25	1	222.1 (Andalusian)
45C	-	10	1	
45A	0.22	80	5	222.3-4
45B	0.47	105	3	222.5
35	-	20	5	
31	0.52	620	35	222.6-8
28	-	15	1	222.2
27	-	5	1	
22	-	15	3	
21A	6.61	10,315	611	222.9-22, 223.23-43, 224.44-50
20	0.52	315	28	
13	-	70	9	
9	-	20	1	
<b>TOTAL</b>	<b>8.34</b>	<b>11,625</b>	<b>705</b>	

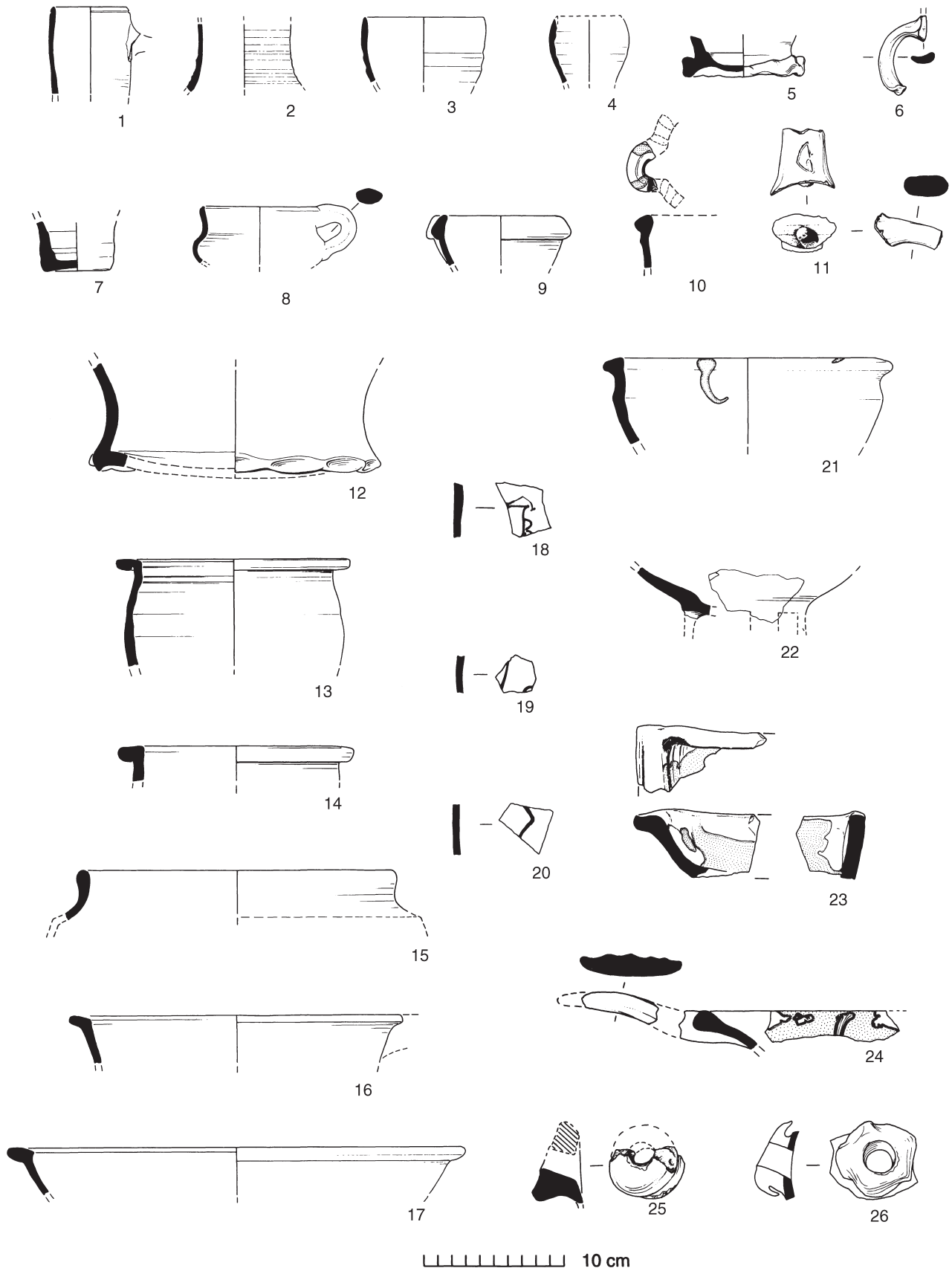

Fig 220 Stratified Group 9: LWC MF22/F52/F53 (town wall), c 1382-1421 (nos 1-26). 1:4. [Pages 322, 324-5]

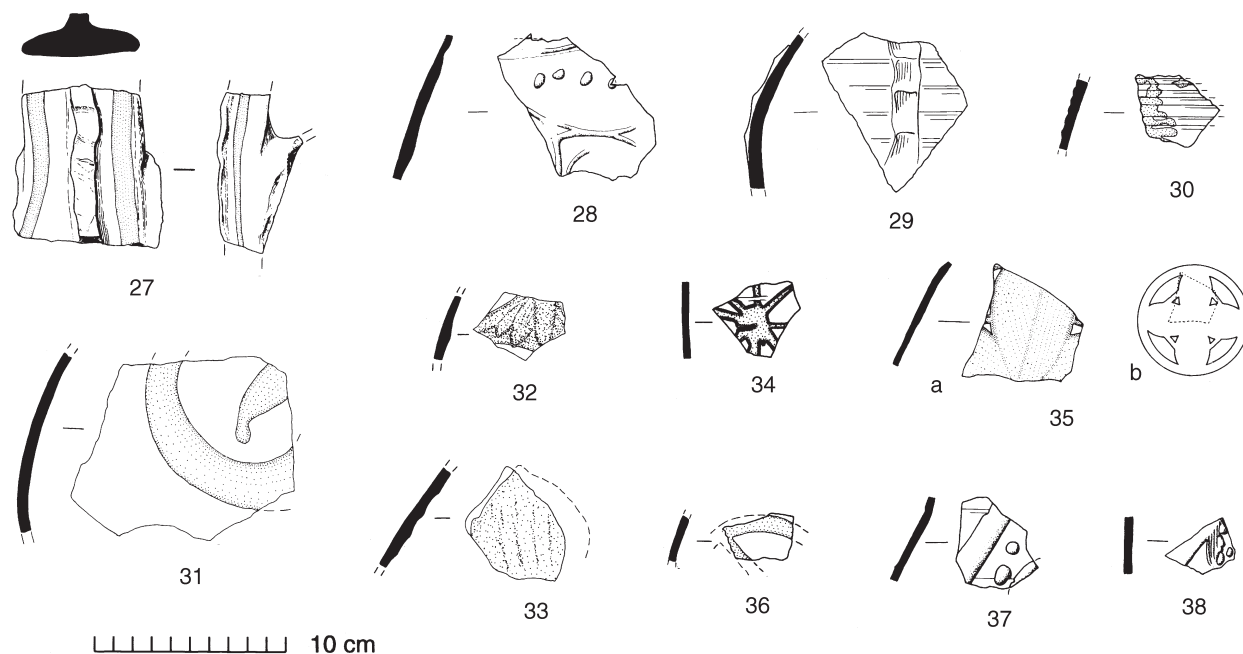

Fig 221 Stratified Group 9: LWC MF22/F52/F53 (town wall), c 1382-1421 (nos 27-38). 1:4. [Page 322]

### Group 11: LWC BF45 (c 1425-1475)

[Fig 225]

#### Large pit (CAR 3, fig 60, sheet 2a)

Dating evidence relies exclusively on the pottery. However, the Colchester-type ware is very similar in character to that from nearby pit BF46 which contained a coin deposited c 1400 (see p 112). The latest piece is another ambiguous Langerwehe or Raeren stoneware sherd. Possibly the group should be dated closer to 1425 than 1475; the shapes of the Siegburg jugs would tend to support this view as would the parallels for the slip-decorated Colchester-type bowl (Fig 225.10). It is obvious, however, that many pieces in this group are residual (Fabrics 13, 20, 22, 35 and 36). Nevertheless some of these are of typological interest in themselves.

Fabric	EVEs	Weight (g)	Sherds	Figs
45C	-	5	1	
45A	-	15	4	
45B	1.14	275	27	225.1-3
36	-	20	2	225.5
35	-	10	2	
31	-	10	2	
23E	-	25	1	
22	0.15	100	7	225.4
21A	1.55	2,325	114	225.6-15
20	0.18	1,265	79	225.16-25
13	0.41	470	32	
9	-	5	1	
<b>TOTAL</b>	<b>3.43</b>	<b>4,525</b>	<b>272</b>	

### Group 12: LWC CF65 (c 1475-1525)

[Not fully illustrated]

#### Large pit (CAR 3, fig 61, sheet 2b)

The dating of this group again hinges entirely upon the pottery, which agrees with the sparse stratification, ie it predates a pit complex of the early 17th century. The group has not been fully illustrated, although several pieces are illustrated in the typology. Large amounts of food bones (mostly chicken), an iron knife-blade and the presence of ceramic chafing dishes (Fig 102.207) suggest kitchen/dining-room refuse.

Fabric	EVEs	Weight (g)	Sherds	Figs
45A	-	10	4	(iron-washed sherds)
45B	-	105	7	(frilled jug base)
45C	0.33	330	13	(Raeren drinking mugs)
41	0.08	10	5	(wide pedestal cup)
40	-	10	1	(early style, slip-painted)
35	0.11	55	5	(Baluster jug rim)
31	0.47	385	28	(includes cauldron rim)
27	-	20	1	(Saintonge green monochrome)
23E	-	5	1	(Cheam white ware)
22	0.18	90	8	
21A	6.26	14,075	1,016	83.62, 88.99, 92.134, 99.191, 102.207, 104.228
20	0.22	260	21	
13	-	100	11	
98S	0.08	170	5	126.4 (non-local slip-painted)
<b>TOTAL</b>	<b>7.73</b>	<b>15,625</b>	<b>1,126</b>	

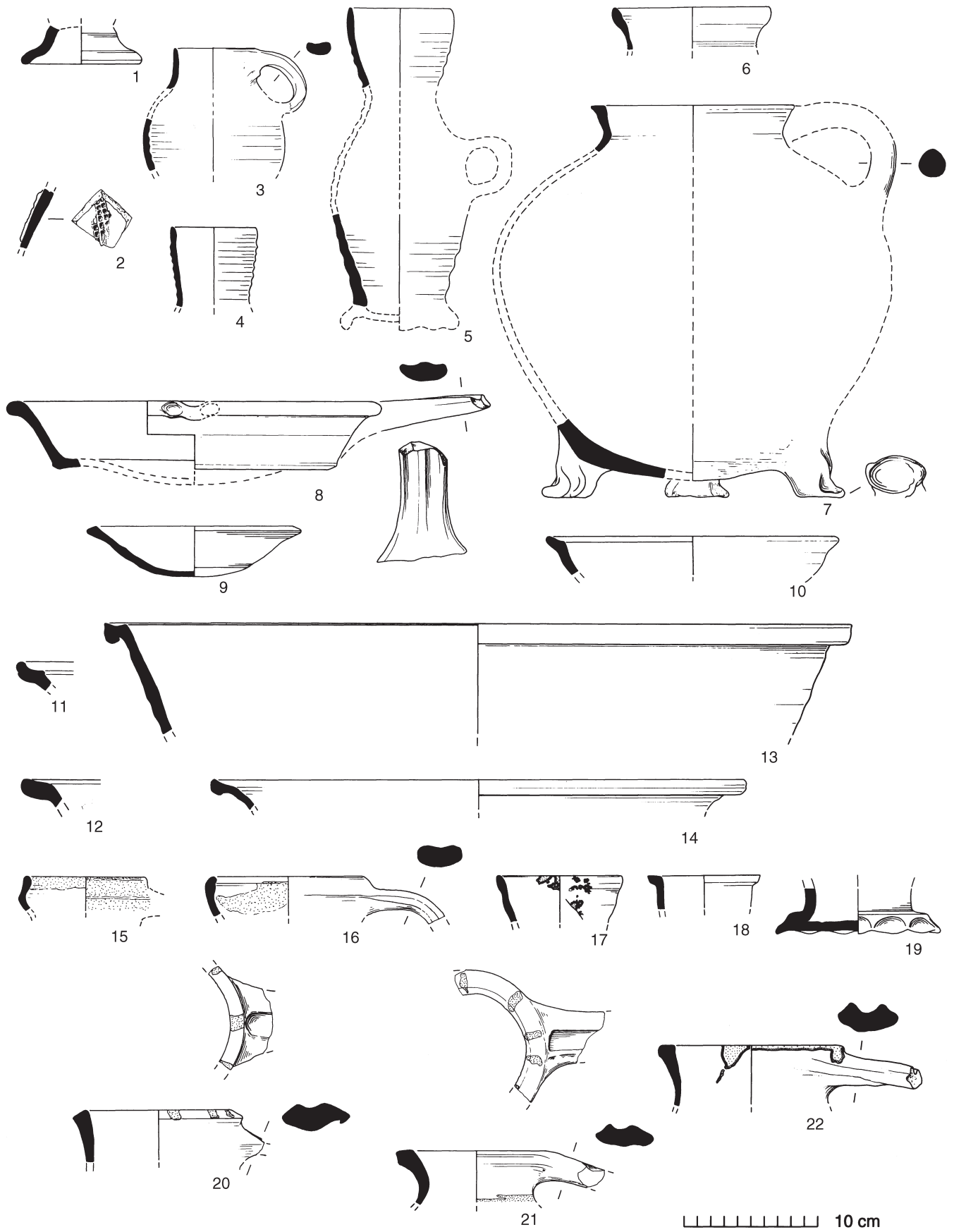

Fig 222 Stratified Group 10: LWC LF33, c 1400-50 (nos 1-22). 1:4. [Pages 323, 326-8]

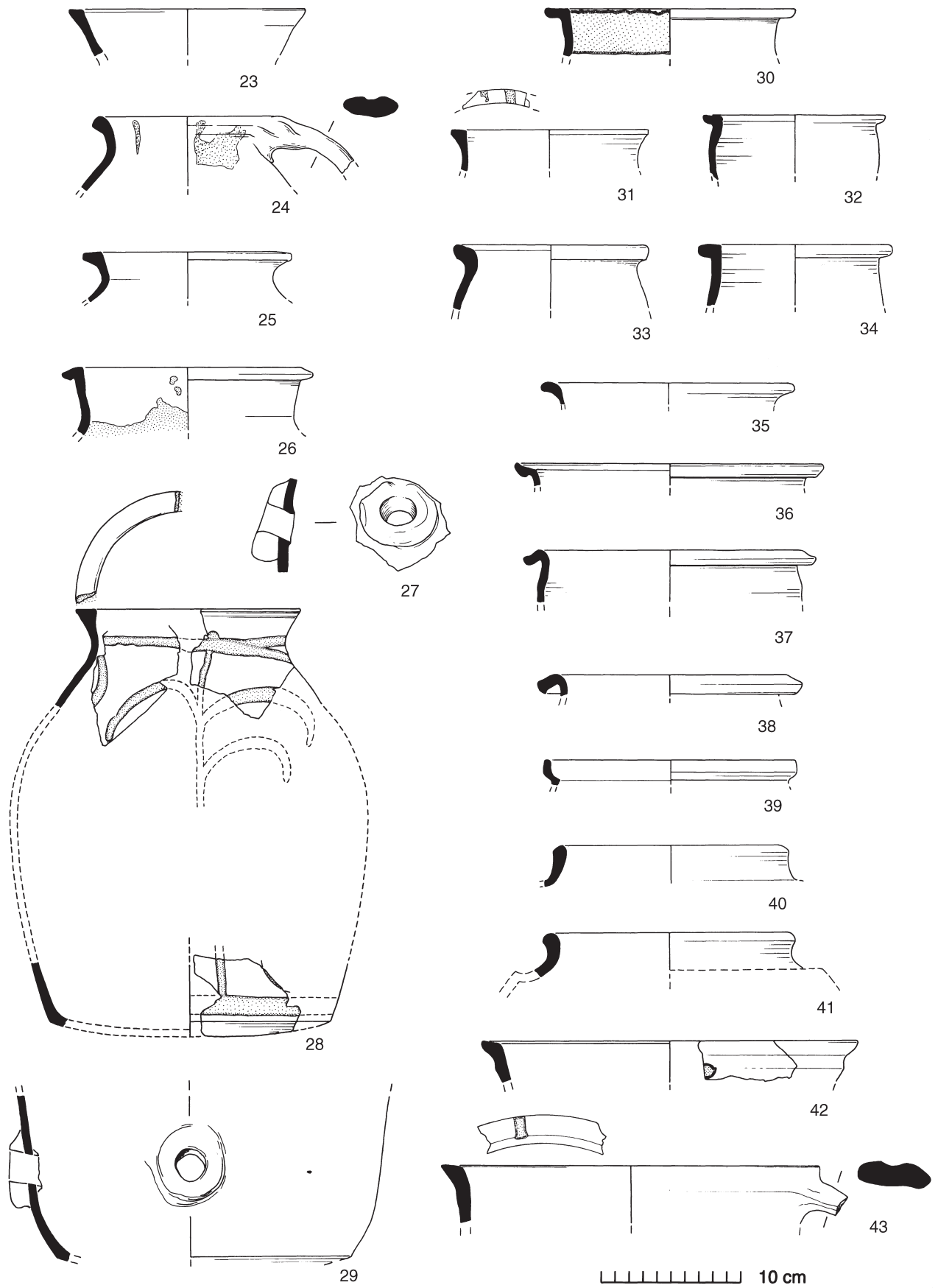

Fig 223 Stratified Group 10: LWC LF33, c 1400-50 (nos 23-43). 1:4. [Pages 323, 326-8]

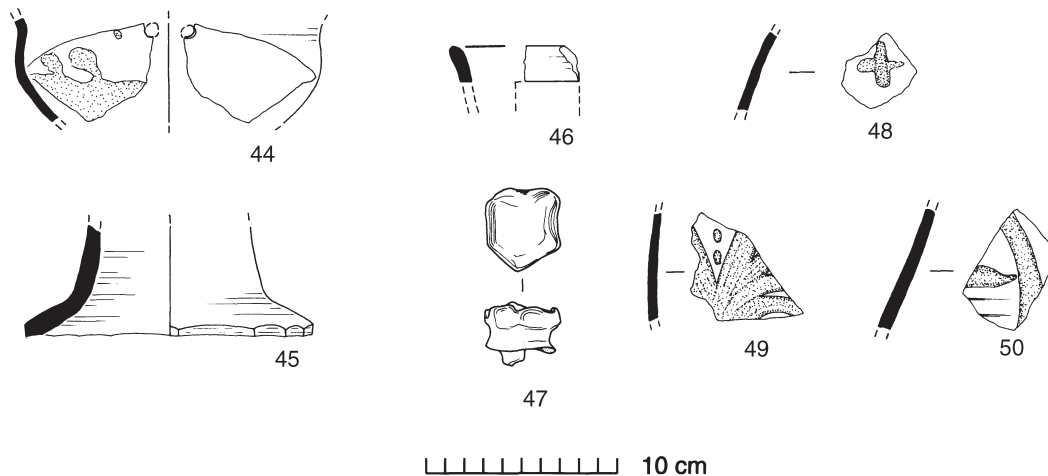

Fig 224 Stratified Group 10: LWC LF33, c 1400-50 (nos 44-50). 1:4. [Pages 323, 326-8]

**Group 13: SPT F14** (c 1500-1525)

[Figs 226-7]

Deep brick- and stone-lined latrine. No stratigraphical relationships were recovered nor any non-ceramic finds other than a few copper-alloy pins of type 1 and some lace-ends of type 1, c 1375-1550/75 (CAR 5, 9 & 13). Square latrines of similar construction have been observed on a number of other sites in Colchester and apparently date to the 15th and 16th centuries (CAR 3, 190). Closer dating, however, rests solely on the ceramic evidence, ie principally the presence of Raeren drinking mugs, the Netherlands flower vase, the incipience of Fabric 40, and the general similarity of the assemblage to Group 14.

Fabric	EVEs	Weight (g)	Sherds	Figs
46C	0.07	5	1	226.1
45A	1.60	710	8	226.2-3
45C	0.69	555	10	226.4-7
40	-	75	1	226.10
31	-	220	2	226.8-9
21A	1.14	6,095	97	226.11-18, 227.19-20
<b>TOTAL</b>	<b>3.50</b>	<b>7,660</b>	<b>119</b>	

early 16th century (*ibid*); Raeren stoneware drinking mugs (c 1475-1550). Other finds: copper-alloy pins of types 1 and 2 (CAR 5, 9), and lace-ends of type 1, c 1375-1550/75 (*ibid*, 14). Also fragments of glass alembics (Rachel Tyson, pers comm) which complement the ceramic industrial base (Fig 105.238) which would have formed the lower part of an industrial distillation unit (with the alembic on top), thus pointing to the presence of pharmaceutical or alchemical practices in the vicinity (?apothecaries).

Fabric	EVEs	Weight (g)	Sherds	Figs
55	0.19	220	2	127.1 (Guy's ware)
45A	1.15	465	12	188.5 (cream/buff fabrics)
45C	1.59	895	24	191.12 (face mug)
40C	0.13	5	1	125.1 (Cistercian ware)
27	-	5	1	(Saintonge green monochrome)
21A	6.14	9,085	248	94.155, 98.176-177, 105.238
20	-	120	5	
13	-	5	1	
9	-	25	1	
1	-	10	1	
<b>TOTAL</b>	<b>9.20</b>	<b>10,835</b>	<b>296</b>	

**Group 14: 1.81 EF14/F19** (c 1525)

**Large twin pit**

The contents of this pit group are not fully illustrated. However, many significant pieces have been illustrated and these may be found in the typology section (see below). The Colchester ware forms (Fabric 21A) and the Rhenish stonewares have much in common with Groups 12, 13 and 15. Dating evidence: worn coin of Edward IV, minted pre-1483 (CAR 6, appendix 10); Nuremberg token, French type,

**Group 15: 1.81 HF39/F158** (c 1525-50)

[Figs 228-9]

Stone and brick 'Tudor' cellar (HF39) with robbed-out timber stairs (HF158) (Building 129, CAR 6, 125, figs 3.9 & 3.72). Dating evidence: residual longcross penny. The latest pottery in this group is the Cologne stoneware jug (Fig 228.3) which is typical of the first half of the 16th century. Some sherds of local post-medieval redware (Fabric 40) also make their appearance in this group.

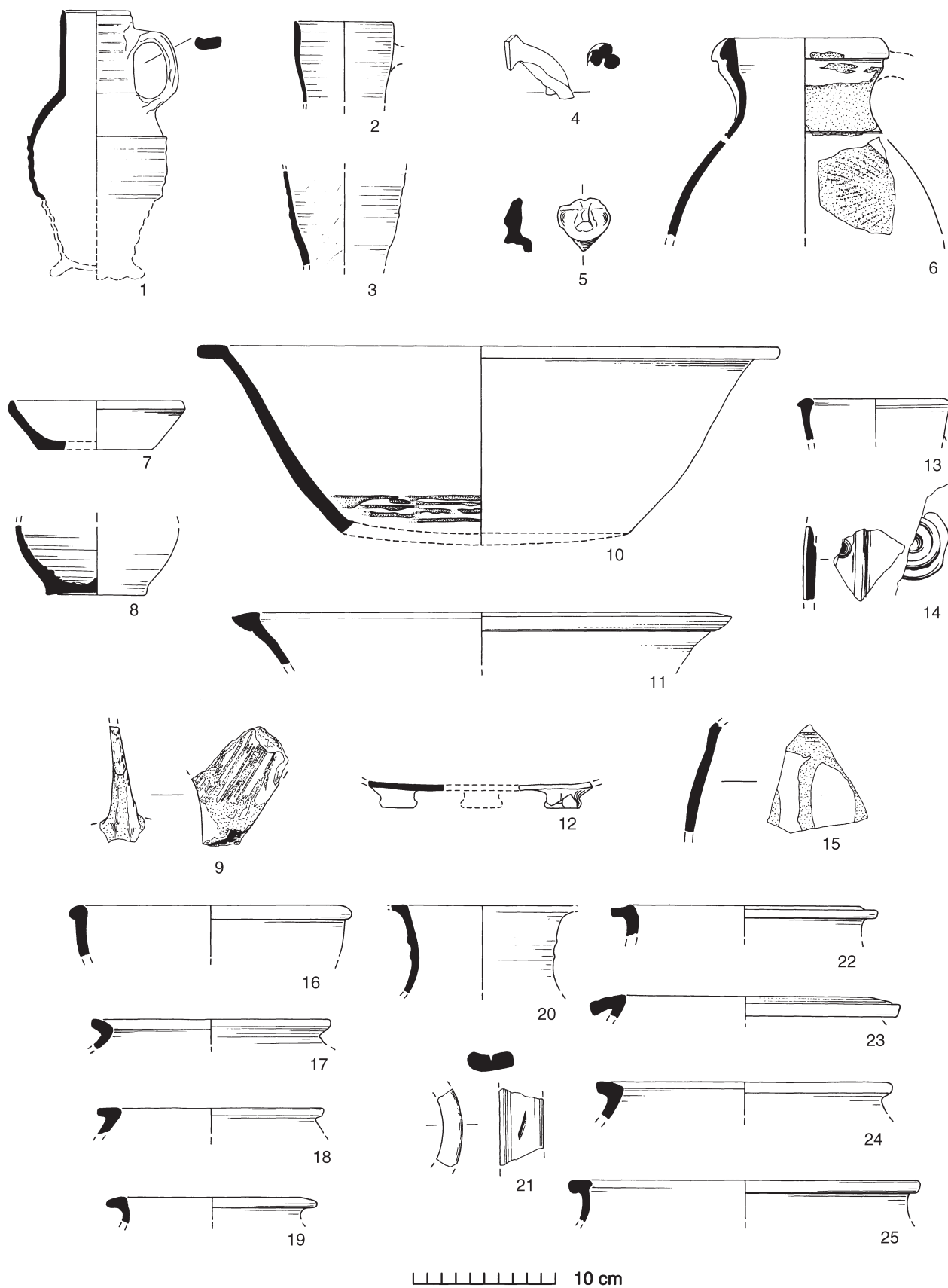

Fig 225 Stratified Group 11: LWC BF45, c 1425-75 (nos 1-25). 1:4; stamp detail on no 14 at 1:1. [Pages 325, 329]

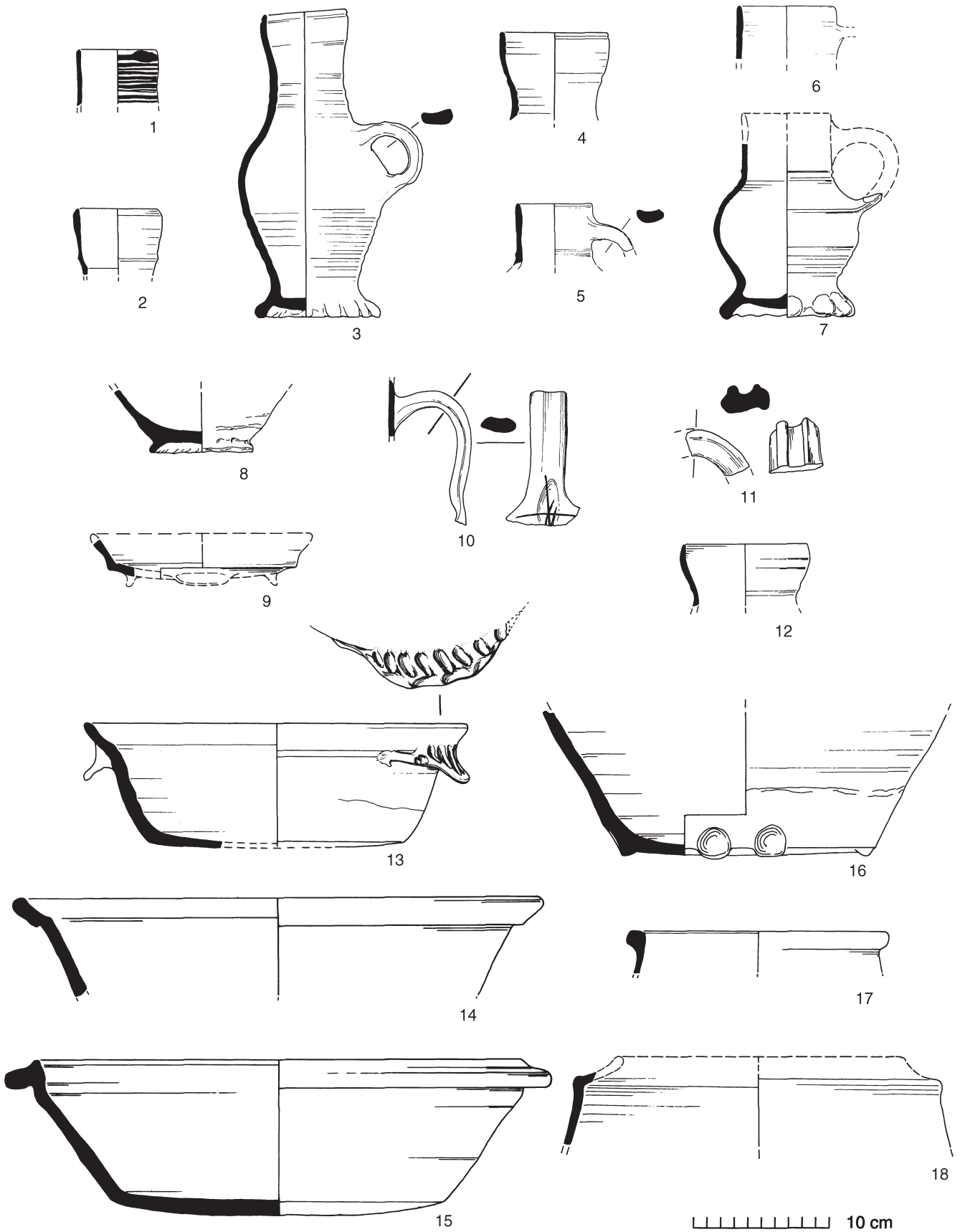

Fig 226 Stratified Group 13: SPT F14, c 1500-25 (nos 1-18). 1:4. [Pages 328, 330-31]



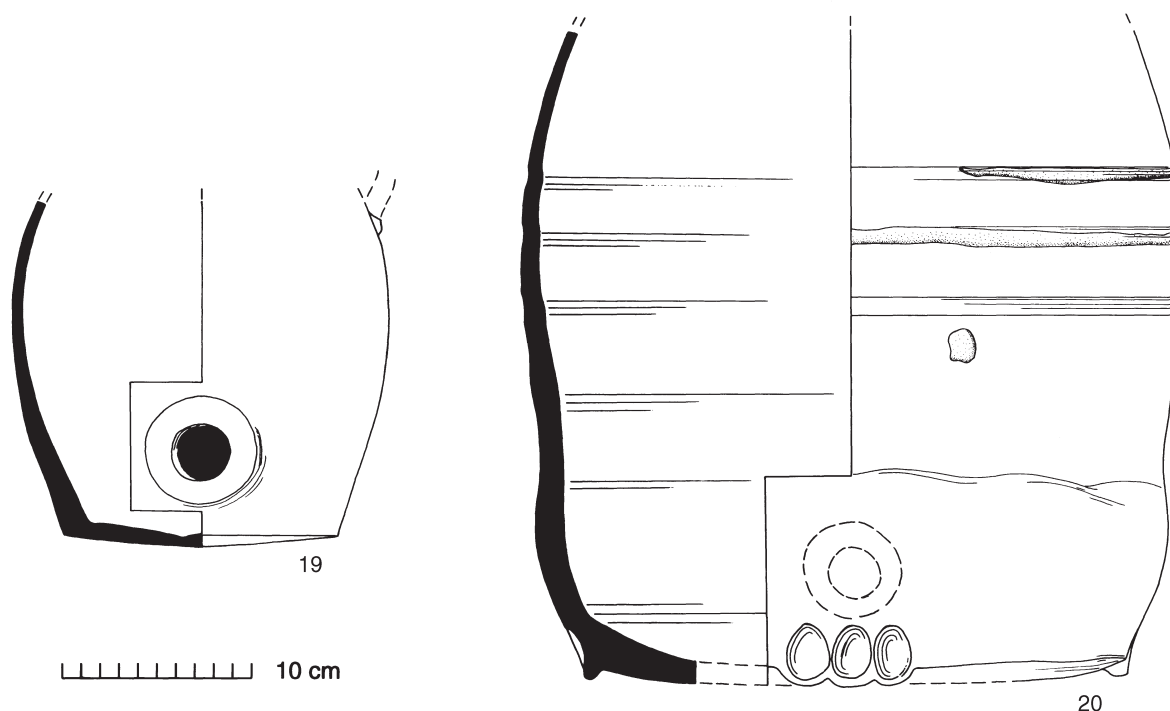

Fig 227 Stratified Group 13: SPT F14, c 1500-25 (nos 19-20). 1:4. [Page 328]

Group 15 continued ....

Fabric	EVEs	Weight (g)	Sherds	Figs
55	0.27	25	2	228.1 (Guy's ware ?figurine)
46C	-	15	1	228.2 (South Netherlands flower vase)
45E	0.48	185	4	228.3
45C	1.63	1,880	42	228.4-11
45A	-	45	2	
45B	-	10	1	
40	-	10	1	
31	-	375	7	228.12-13
21A	2.48	7,780	114	228.14-18, 229.19-33
20	0.06	150	2	
13	-	130	2	
<b>TOTAL</b>	<b>4.92</b>	<b>10,605</b>	<b>178</b>	

### Group 16: LWC CF77/F22 (c 1550/75-1575/1600)

#### Intercutting pits

[This is not fully illustrated.]

Group 16 comprises one or two cess-pits. The absence of clay pipes suggests that the context predates c 1600. Otherwise dating depends entirely on the pottery and its resemblance to late 16th-century Chelmsford groups

(Cunningham 1985). This group has not been fully illustrated but the most significant pieces may be found in the typology.

Fabric	EVEs	Weight (g)	Sherds	Figs
45D	0.24	80	7	
45C	-	5	1	
40	2.15	2,830	79	139.80, 146.140 & 147.159
31	0.08	85	5	
22	-	90	3	
21A	0.96	1,680	55	79.39
13	-	80	5	
<b>TOTAL</b>	<b>3.43</b>	<b>4,850</b>	<b>155</b>	

Out of hundreds of excavated pits it has proved a difficult task to isolate and categorically assign any one pit to the second half of the 16th century. Non-ceramic artefacts of this period are rarely found and they rarely have useful archaeological associations. The pottery certainly exists but the dominant local coarseware of this period (Fabric 40) shows insufficient typological development and cannot easily be distinguished from early 17th-century types. Imported stonewares of this period — though abundant — were better curated and consequently occur mostly in 17th-century deposits.

Group 16 is the best that could be found at the time of selecting such pit groups.

Specialist information received at a late stage in the preparation of this monograph suggests that another pit group (LWC KF15), containing many fine late 16th-century tin-glazed drug jars, would have been a wiser choice. The latter group dates to c 1600 and it and its contents are fully illustrated and discussed in the typology (see Fabric 46,

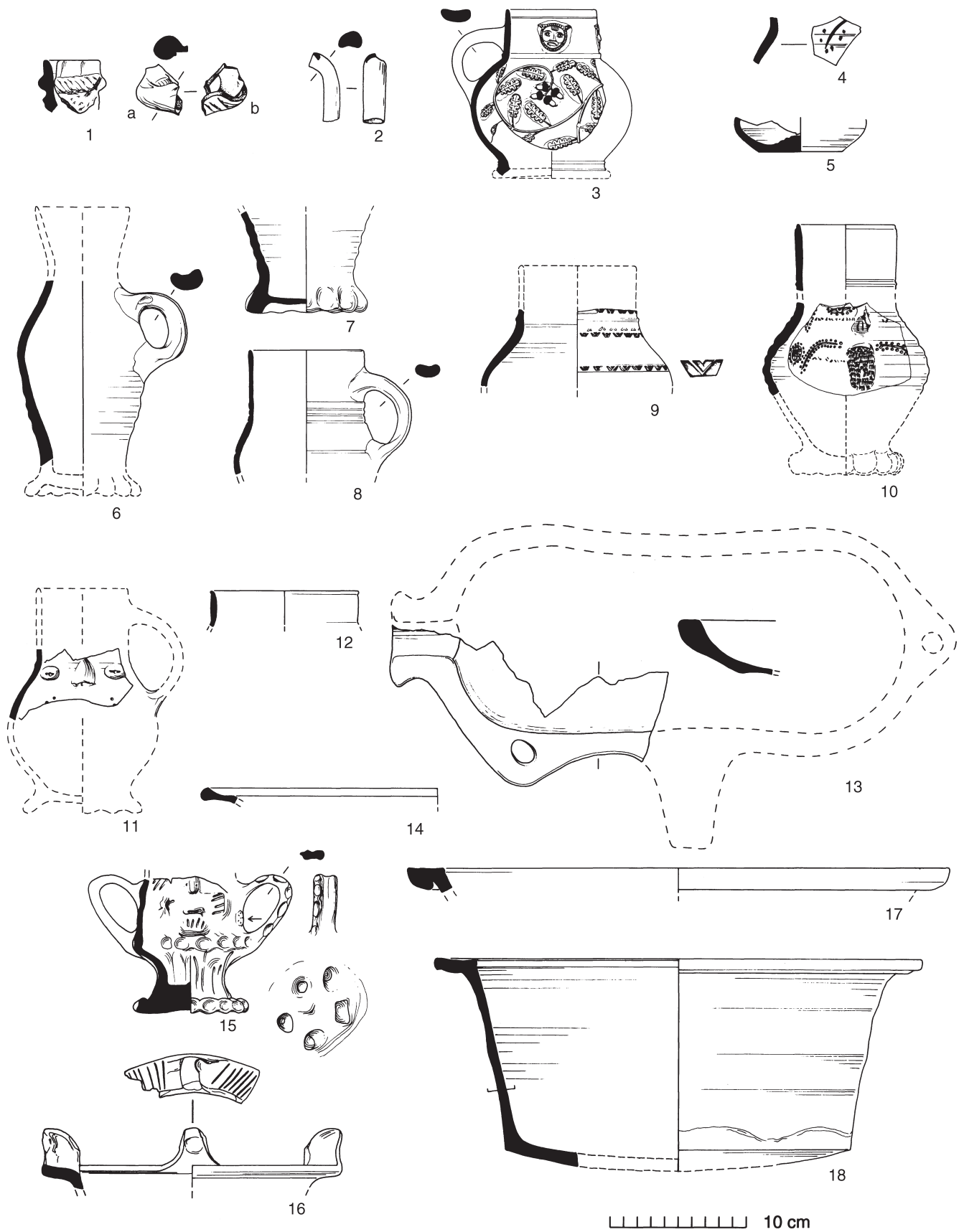

Fig 228 Stratified Group 15: 1.81 HF39/F158, c 1525-50 (nos 1-18). 1:4, stamp detail on no 15 at 1:1. [Pages 328, 331-3]

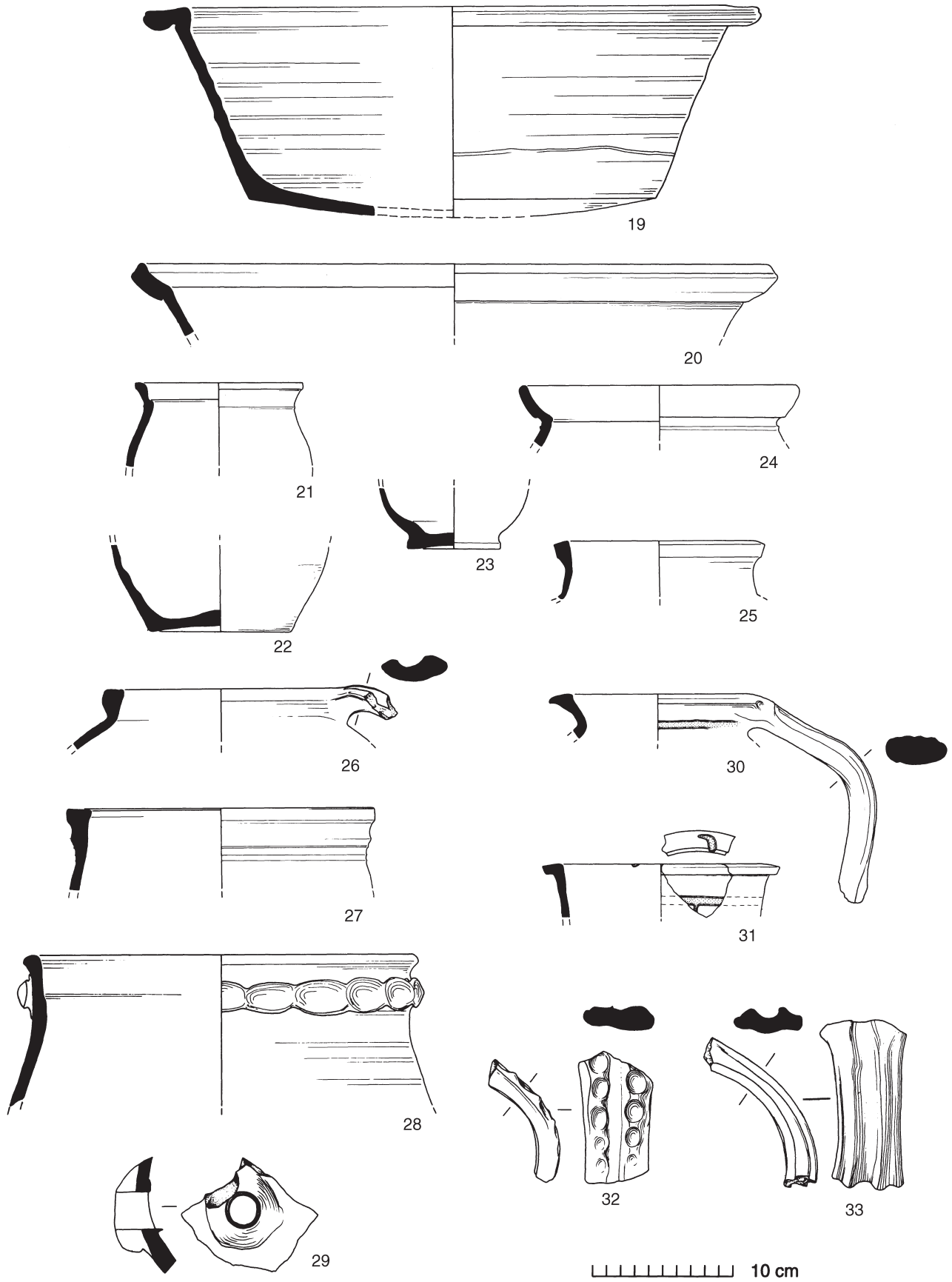

Fig 229 Stratified Group 15: 1.81 HF39/F158, c 1525-50 (nos 19-33). 1:4. [Pages 328, 331-3]

p 232). An excellent late 16th-century group was found in a stone-lined pit or latrine on the Angel Yard site (40.86 F76), dated by the presence of a stoneware medallion of 1585, but again, the whole group is probably closer to *c* 1600. Detailed consideration of this late 16th-century assemblage lies outside the scope of this report.

**Group 17: COC F61** (*c* 1625-1650)

[Figs 230-32]

Large pit to rear of Building 151 (*CAR 6*, fig 13.115). Sealed by F153 of *c* 1800. Other finds include a Charles I coin of 1625-34, and three tokens (stolen, but probably Hans Krauwinkel of Nuremberg 1586-1635). The absence of clay pipes is curious in such a large post-medieval group but could indicate an earlier rather than a later deposition within the suggested date range. The Fabric 40 forms and their generally high-quality fabric also suggest an early 17th-century date, as does the style of the Dutch tin-glazed charger (Fig 230.1). However, there are some heavily burnt pieces in this group (eg Fig 230.3, 9) which could conceivably have resulted from the 1648 siege though there is no convincing evidence for this.

Fabric	EVEs	Weight (g)	Sherds	Figs
46	0.26	125	11	230.1-4
45D	2.56	1,605	41	230.6-7
45C	-	55	2	
42	1.62	405	54	230.8-9
40	10.54	19,600	370	230.15-18, 231.19-32, & 232.33-41
31	0.16	365	11	230.10-14
31A	-	5	1	
95C	-	15	1	230.5 (chafing dish)
98	-	15	1	
21A	0.70	1,315	43	
20	-	75	4	
13	0.04	70	4	
<b>TOTAL</b>	<b>15.88</b>	<b>23,650</b>	<b>543</b>	

**Group 18: LWC GF24** (*c* 1625-1650)

**Large pit** (*CAR 3*, fig 61, sheet 2b)

Clay pipes: three stem fragments

Stratigraphy: F24 cut F29 which contained a Nuremberg token of 1586-1635. This cut F30 which produced a half-groat of Elizabeth I issued 1583-1603. F24 is cut/sealed by ?demolition debris Layer 20 which, as well as including slightly earlier coins and tokens, contained two clay-pipe bowls of 1660-80. It is the largest in an excellent sequence of pits cutting through a daub floor laid down in the 16th century in one of the rooms of a stone house (Building 28, Room 6; *CAR 3*, fig 67). Possibly a series of rubbish-pits which dates the abandonment of the phase. Again, this group has not been fully illustrated, but the assemblage is very similar in character to Groups 17 and 20.

Fabric	EVEs	Weight (g)	Sherds	Figs
55	0.10	80	3	(Guy's ware)
46E	-	20	1	200.2 (Montelupo)
45E	-	45	1	
45D	0.42	405	17	
45C	1.00	165	8	191.17 (panel jug)
45A	0.10	15	1	
44A	0.21	75	4	198.5 (Weser)
43	1.00	85	7	(Martincamp)
42	0.39	210	14	
40	6.64	8,085	409	139.73 & 145.138
31	1.95	3,115	120	180.19
31A	1.15	330	15	183.5
41	-	5	1	
21A	-	105	6	
20	0.11	45	3	
13	-	325	29	
<b>TOTAL</b>	<b>13.07</b>	<b>13,110</b>	<b>639</b>	

**Group 19: LWC VF2** (*c* 1650)

[Fig 233]

**Pit** (Fig 158)

Lion Walk area V is an umbrella code for a number of widely dispersed features. Consequently it has not been indicated on the general plan published in *CAR 3* (fig 61). This pit lay virtually on the north-east corner of Lion Walk and Culver Street, approximately 11 m due east of Building 28. Steep-sided pit, approximately 1.5 m wide. No useful site stratigraphy. Apart from pottery, it produced eighteen clay tobacco-pipe bowls of 1640-60 plus pipes of 1600-40 (*CAR 5*, fig 54.2120 & 2122), deer antler and bottle glass (unavailable for study). The complete triangular 'Hessian' crucible is of a type that appeared in the 15th century but is commonly shown in Dutch *genre* paintings of the mid-to-later 17th century. Upon cleaning, it was found to contain droplets of mercury suggestive of pharmaceutical or alchemical practices (see pp 289-90). Of the tin-glazed drug jars in the group (Fabric 46), Figure 233.7 was found complete and the smaller turquoise blue jar Figure 233.6 had only a chip missing from the rim. Many of the vessels in this group are so nearly complete that it seems likely they were discarded whole. The geometric-band drug jars and the blue-dash charger rim (Fig 233.8), in combination with the pipe evidence, suggest a deposition date of *c* 1650. In the section on tin-glazed wares (pp 232 & 234), it is suggested that the dumping of the material in this group and Stratified Group 20 (below) may be connected with the death in 1655 of Robert Buxton, a local apothecary.

Fabric	EVEs	Weight (g)	Sherds	Figs
60	1.00	95	1	233.10 (crucible)
55	-	475	2	233.13 (Guy's ware)
46	2.88	2,660	49	233.1-8
45D	1.00	1,820	37	233.9
42	0.20	115	2	233.11-12
40	1.90	4,445	28	233.14-17
31	-	55	3	
<b>TOTAL</b>	<b>6.98</b>	<b>9,665</b>	<b>122</b>	

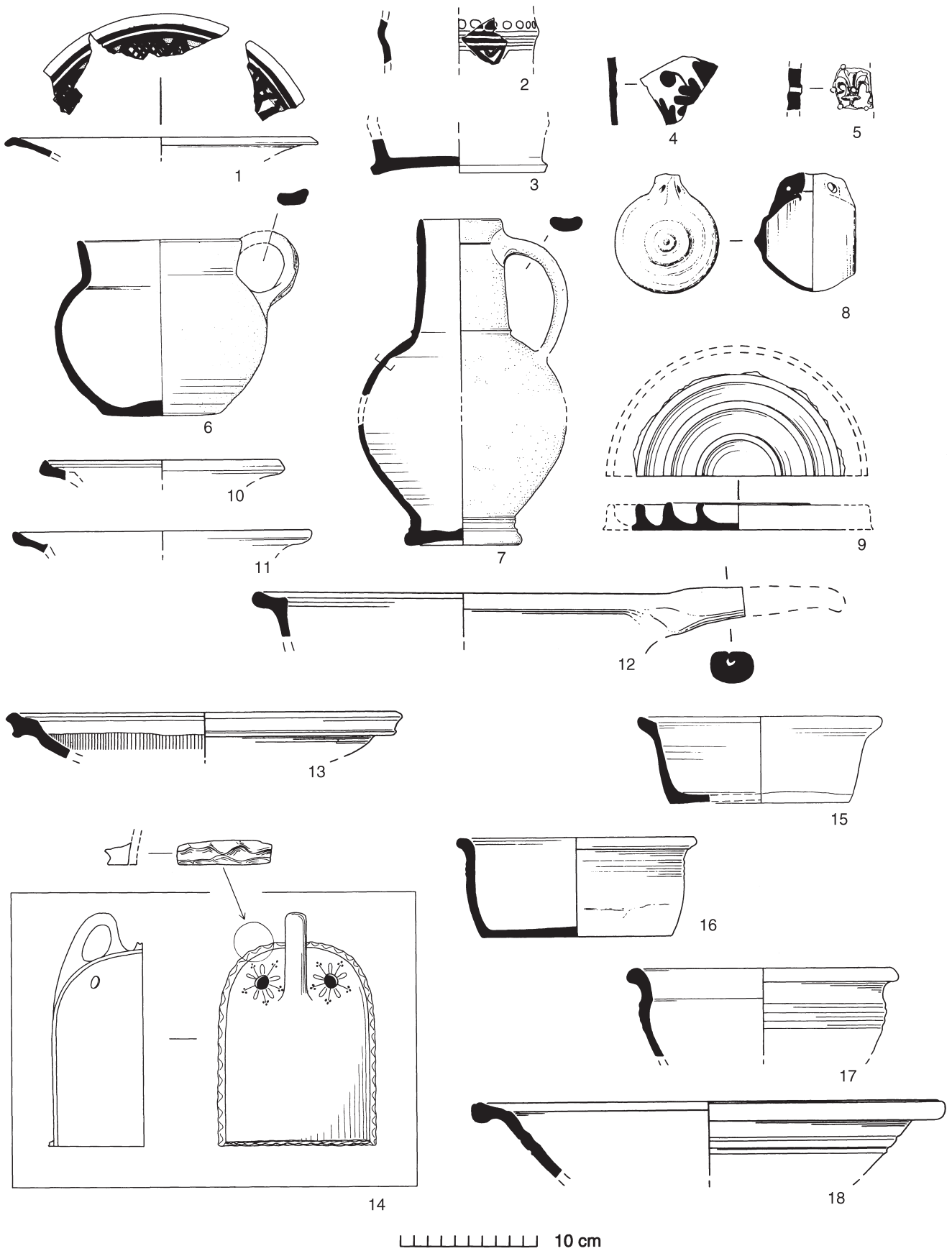

Fig 230 Stratified Group 17: COC F61, c 1625-50 (nos 1-18). 1:4. [Pages 334-7]

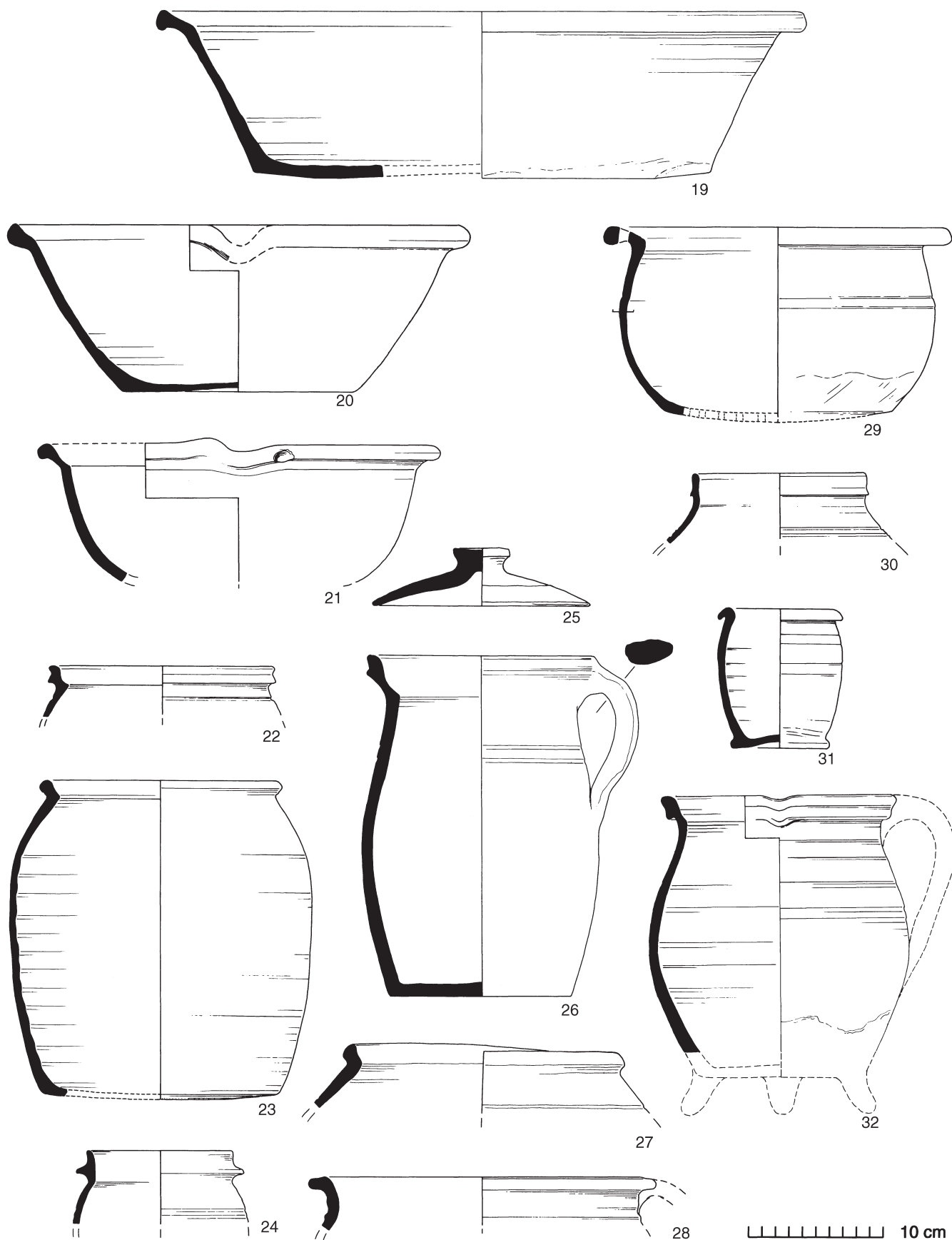

Fig 231 Stratified Group 17: COC F61, c 1625-50 (nos 19-32). 1:4. [Pages 334-7]

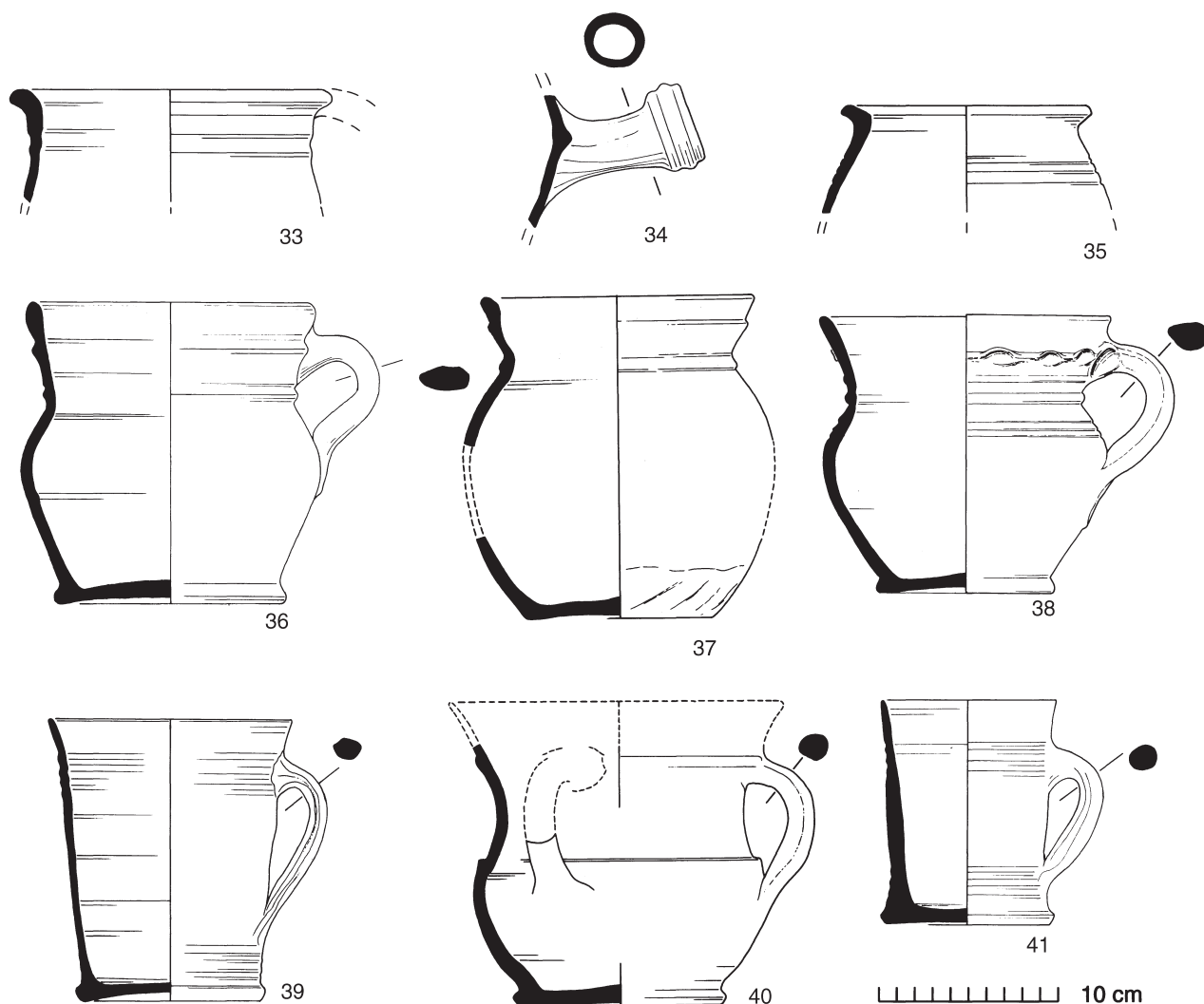

Fig 232 Stratified Group 17: COC F61, c 1625-50 (nos 33-41). 1:4. [Pages 334-7]

### Group 20: LWC BF14 (c 1650)

[Figs 234-9]

Boundary ditch or wall robber trench (Fig 158, see also *CAR 3*, sheet 2a, fig 60). A north-south boundary ditch is marked in approximately this position on Morant's 1748 map of Colchester. Other finds included four clay tobacco-pipe bowls of 1640-60, a Nuremberg token (stolen, but most likely Hans Krauwinkel 1586-1635), and two bone knife-handles one of which was carved in the shape of a horse's hoof (*CAR 5*, fig 75.3084-5).

This feature was exposed following site clearance and after cleaning of Layer 27 which produced two other Nuremberg tokens of 1586-1635 and four clay-pipe bowls of 1580-1640. Numerous cross-joins exist between pottery from BF14 and Layer 27 and also between these contexts and BF19. The latter appears inextricably linked with BF14 and may be a slot parallel to it. Finds from BF19 included a coin of Charles I of 1636-44 and six clay-pipe bowls of 1600-1640.

A stoneware rim of c 1825-75 was intrusive into this group. More problematical is part of a distinctive Westerwald tankard (Fig 235.16) of a type generally dated to c 1700 (Reineking von Bock 1971, nos 610-13). Unless this is an unusually early example of this form, it also must be regarded as an intrusive element, as nothing else in the group suggests a date as late as this. Many vessels, particularly the imported stonewares and tin-glazed wares, can be dated stylistically to the second half — or more likely the last quarter — of the 16th century. As so many were nearly complete at disposal, they must have been well-curved. This also applies to a degree to the local coarse-wares (Fabric 40), whose general characteristics might otherwise have suggested a date closer to 1625 than 1650, though some of these forms continued into the second half of the century. The latest pieces in the group are the tin-glazed drug jars with geometric decoration which are usually dated c 1625-50. These along with the coin and clay-pipe evidence point to a deposition date of c 1650. Along with Group 19, it is suggested in the discussion on tin-glazed wares (pp 232 & 234) that this group is connected with the death in 1655 of Robert Buxton, a local apothecary.

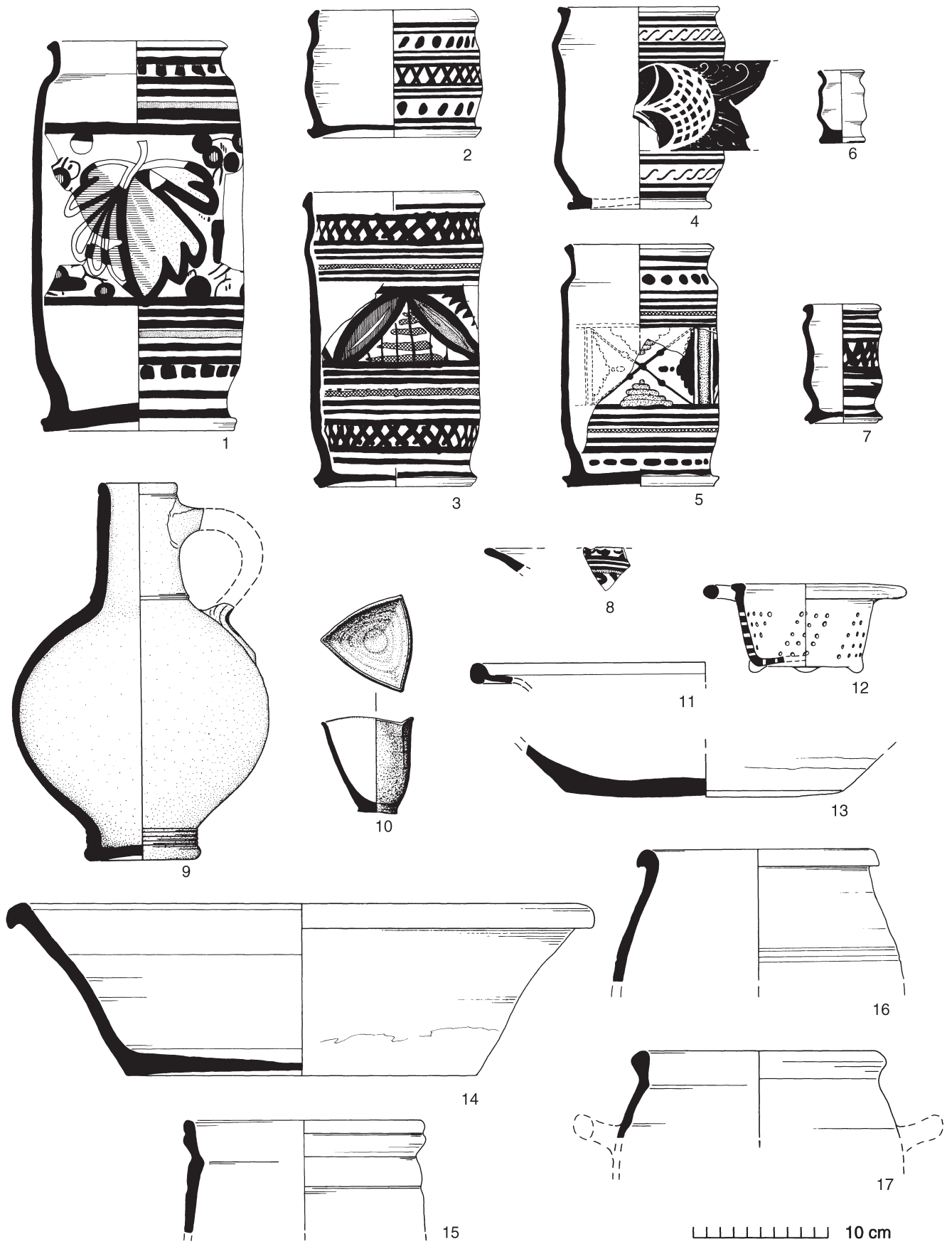

Fig 233 Stratified Group 19: LWC VF2, c 1650 (nos 1-17). 1:4. [Pages 334, 338]





Fig 234 Stratified Group 20: LWC BF14, c 1650 (nos 1-14). 1:4, except detail on no 14 at 1:2. [Pages 337, 339-44]

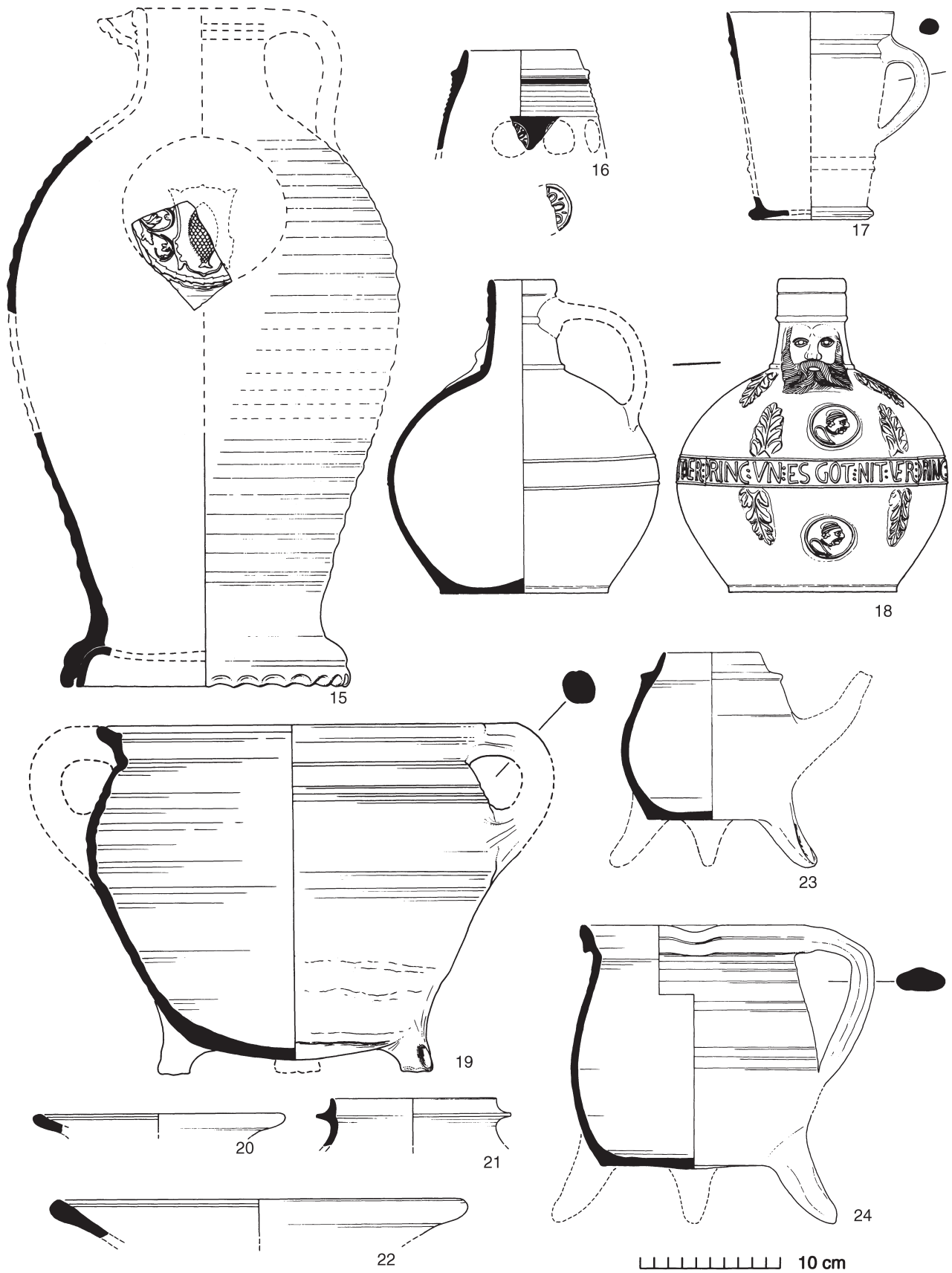

Fig 235 Stratified Group 20: LWC BF14, c 1650 (nos 15-24; no 16 ?intrusive). 1:4, except detail on no 16 at 1:2. [Pages 337, 339-44]

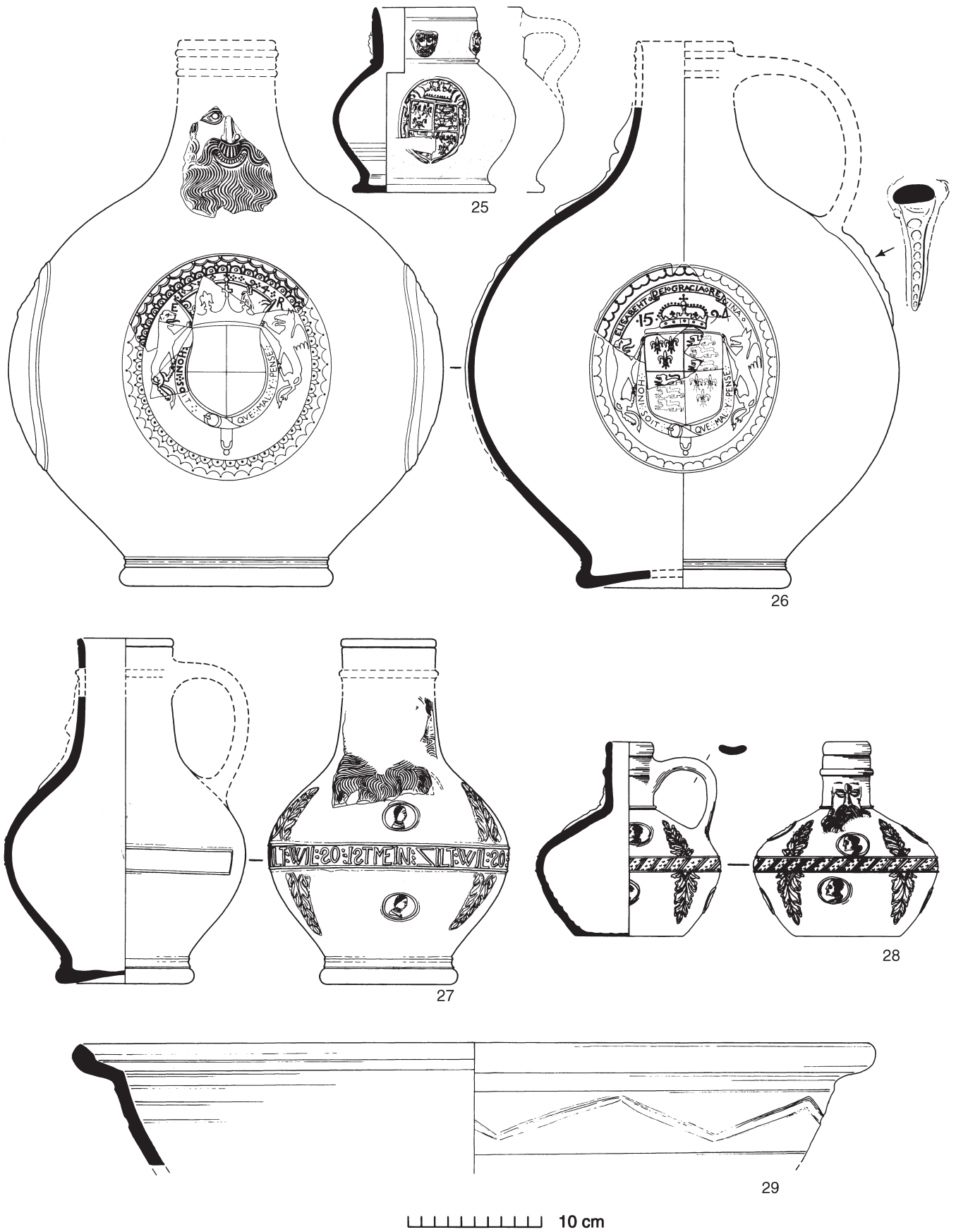

Fig 236 Stratified Group 20: LWC BF14, c 1650 (nos 25-29). 1:4. [Pages 337, 339-44]

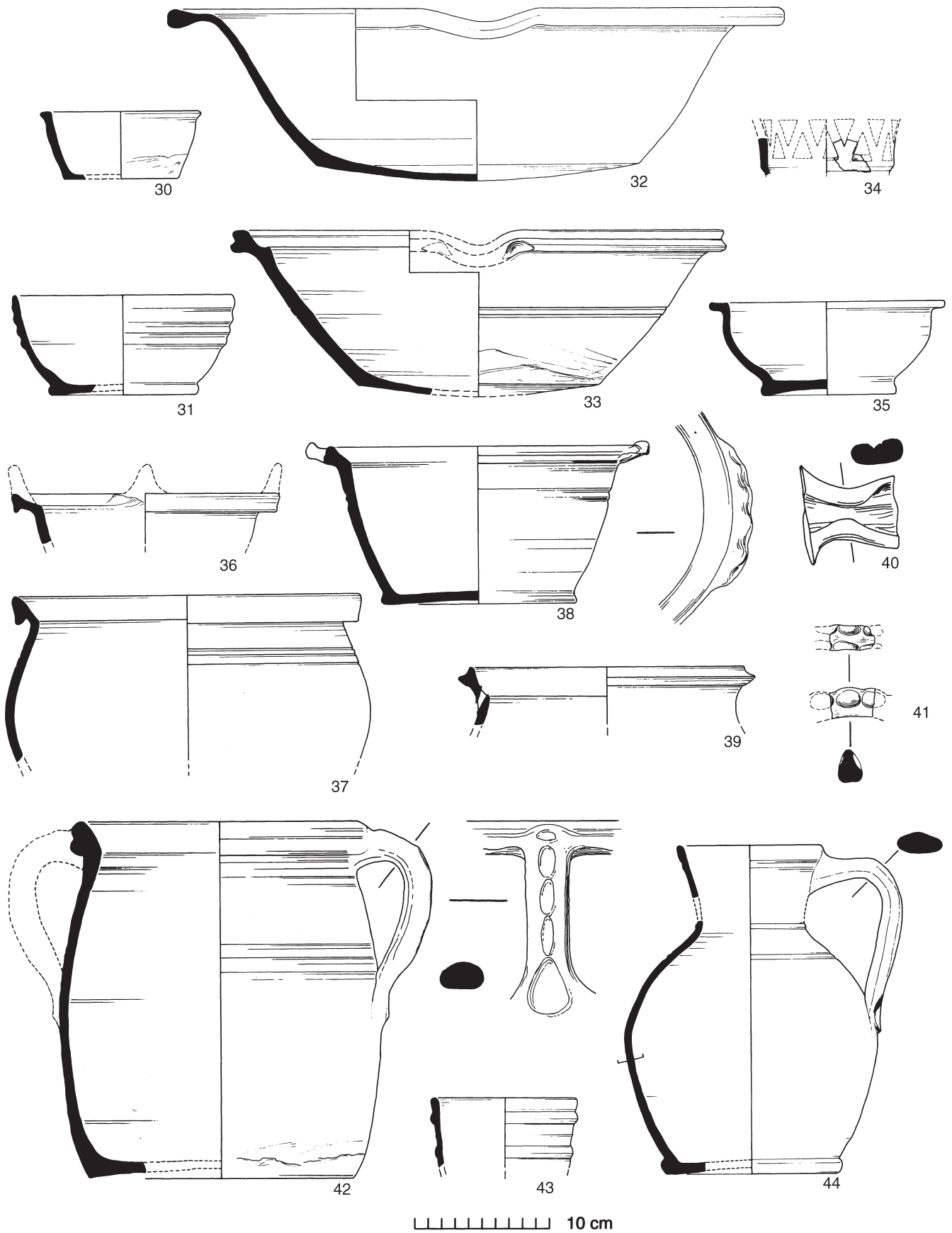

Fig 237 Stratified Group 20: LWC BF14, c 1650 (nos 30-44). 1:4. [Pages 337, 339-44]

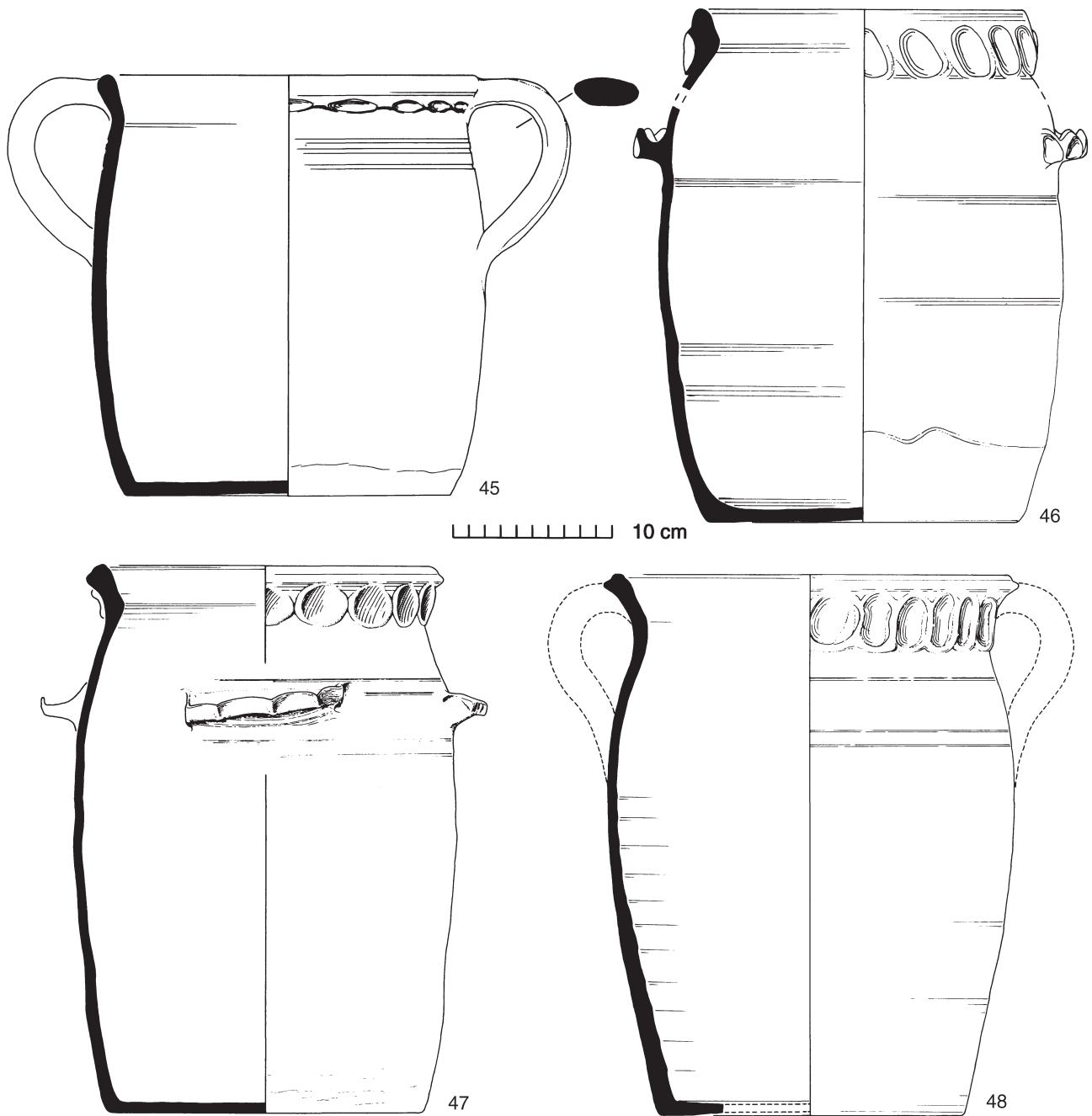

Fig 238 Stratified Group 20: LWC BF14, c 1650 (nos 45-48). 1:4. [Pages 337, 339-44]

Group 20 continued ....

Fabric	EVEs	Weight (g)	Sherds	Figs	44B	-	20	2	(Werra)
55	0.18	740	10	236.29 (Guy's ware)	42	-	10	2	(Border ware)
46	3.47	1,785	121	234.1-11	40	13.77	34,825	1,080	235.17, 20-24
45F	0.19	40	1	235.16 (?intrusive)					237.30-44, 238.45-48
45D	4.16	4,550	185	234.12-14, 235.18 & 236.25-28	31	1.01	1,970	81	& 239.49-50
45C	0.13	45	3		41	0.06	10	2	235.19
45A	-	485	24	235.15 (Lang/Raeren)	29A	-	60	6	(olive jar)
45B	-	10	1		21A	-	390	19	
44A	-	5	1	(Weser)	20	-	50	3	
					13	-	50	4	
					<b>TOTAL</b>	<b>22.97</b>	<b>45,045</b>	<b>1,545</b>	

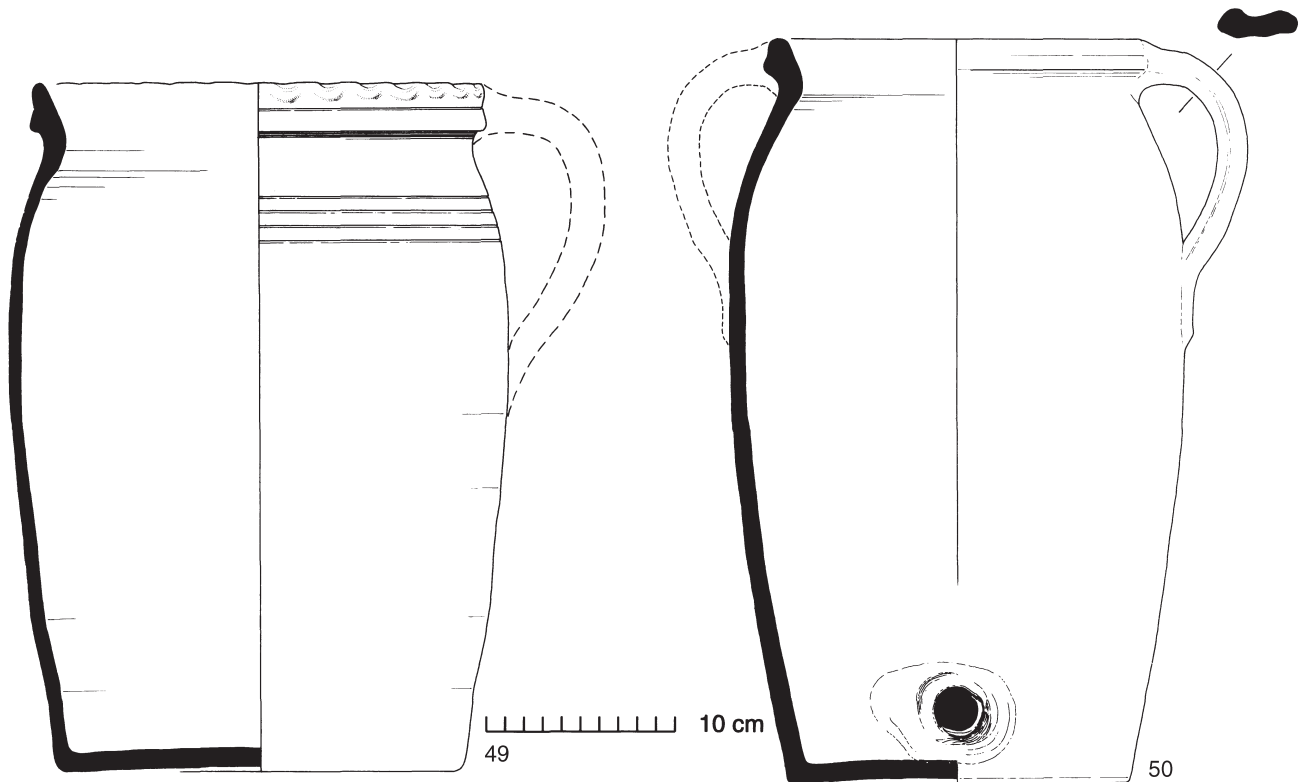

Fig 239 Stratified Group 20: LWC BF14, c 1650 (nos 49-50). 1:4. [Pages 337, 339-44]

**Group 21: MID AF15** (c 1680-1700)

[Figs 240-44]

Large pit to rear of Building 75, Middleborough site (CAR 3, fig 190). No very useful stratigraphy: the pit cuts a much earlier robber trench (F23) and is sealed by topsoil (L1), all of this sealed c 1862 when the new cattle market was laid out. Other finds include over 100 clay tobacco-pipe bowls of 1660-80, two of 1670-1700 and one of 1680-1710 (CAR 5, fig 56.2775). Also prolific animal bone, glass and iron objects (not presently available for study).

The presence of several jugs, drinking vessels and chamberpots, and in particular the unusually large quantity of clay pipes and animal bones, is all strongly suggestive of tavern refuse. It is not known if Building 75 was ever a tavern prior to its demolition in 1862. However, it is known that nearby Building 76 became the New Market Tavern in the same year, but it is not known if it ever served this function before that date. Two London stoneware tankards of c 1750+, from elsewhere on the site, carry inscriptions which may be the name of an inn-keeper (Fig 168.4). These add some weight to the suggestion of an earlier tavern somewhere in the Middleborough vicinity.

The latest pottery types present in this group, mainly the Bellarmines, the Westerwald stoneware and the Staffordshire slipware, are consistent with a late 17th- or even early 18th-century date and are in accord with the latest clay-pipe dates. It is clear however that there is some earlier material in this group. Certain of the tin-glazed chargers (Fig 240.6, 7 & 9) are closely matched by examples from the 1666

Great Fire of London deposits (Alan Vince, pers comm). The Werra and Weser slipware dishes (Fig 241.28-29) must date to the late 16th or early 17th century, and similarly the fragments of Raeren panel jug (Fig 191.20) date from c 1580-1600. This group of older wares could in part represent more carefully curated display wares, though some earlier wares are abraded and clearly residual, including the Saintonge jug handle and the relatively large quantity of early medieval sandy ware (Fabric 13) which clearly derives from the nearby kilns.

Fabric	EVEs	Weight (g)	Sherds	Figs
50	-	30	2	241.37 (Staffordshire slipware)
46	1.54	1,410	74	240.1-12
46F	-	20	7	240.13 (Portuguese)
45	1.00	515	8	240.18
45F	0.52	375	16	241.21-27
45D	0.57	1,230	18	240.14-17 & 241.19-20
45C	0.15	65	3	191.20 (Panel jug)
44A	0.10	5	1	241.29
44B	0.07	30	2	241.28
40A	2.07	1,945	53	242.47-57
40	14.33	24,535	603	242.58-62, 243.63-85 & 244.86-105
42	0.99	1,085	46	241.38-46
31A	0.58	330	18	241.32, 34
31	0.30	595	18	241.33, 35-36
23C	-	30	2	241.30-31
41	-	5	1	
27	-	25	1	(?polychrome, jug handle)
21A	0.26	775	13	
13	0.60	990	51	(ex MID kilns)
<b>TOTAL</b>	<b>23.08</b>	<b>33,995</b>	<b>937</b>	



Fig 240 Stratified Group 21: MID AF15, c 1680-1700 (nos 1-18). 1:4. [Pages 344-9]

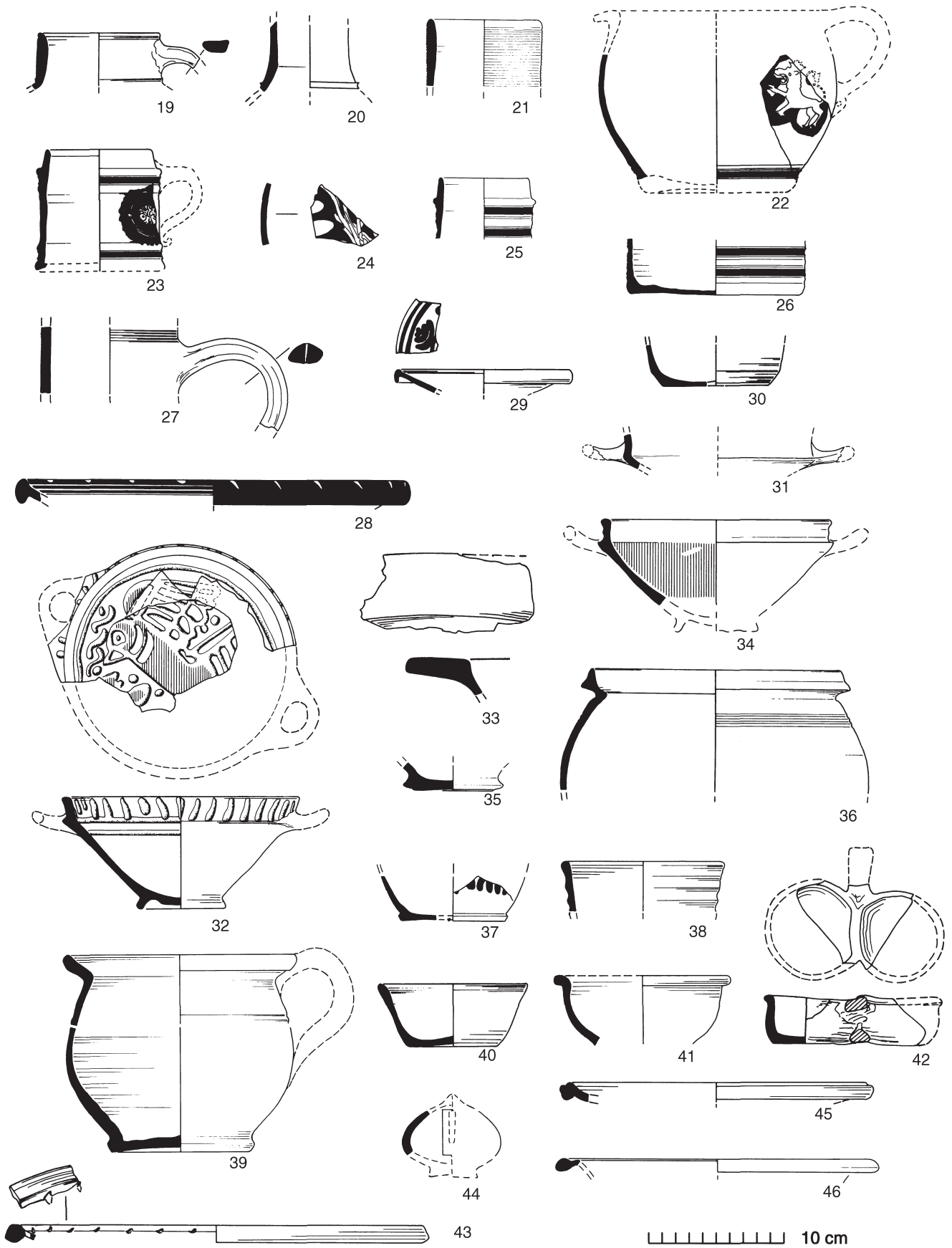

Fig 241 Stratified Group 21: MID AF15, c 1680-1700 (nos 19-46). 1:4. [Pages 344-9]



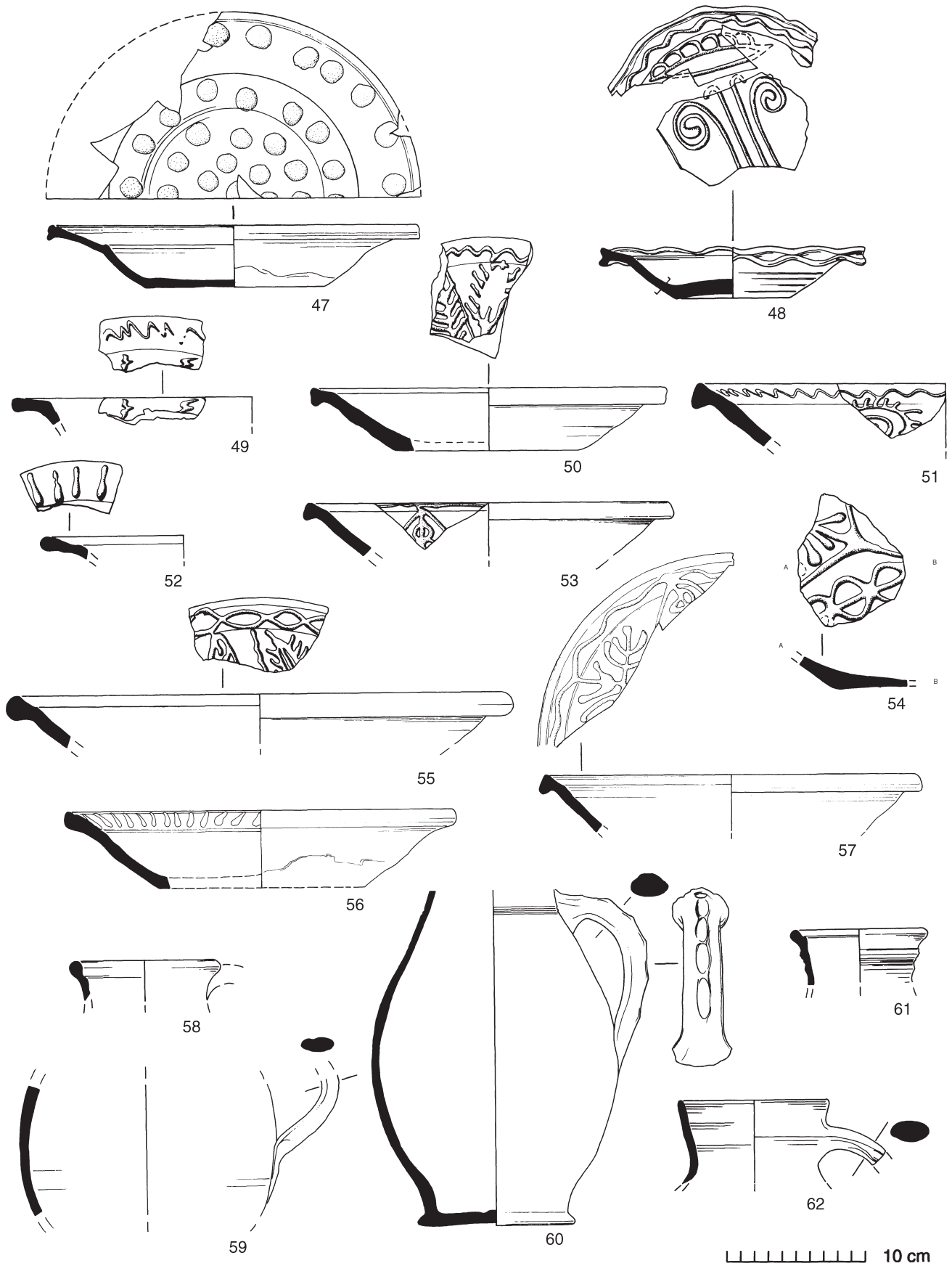

Fig 242 Stratified Group 21: MID AF15, c 1680-1700 (nos 47-62). 1:4. [Pages 344-9]

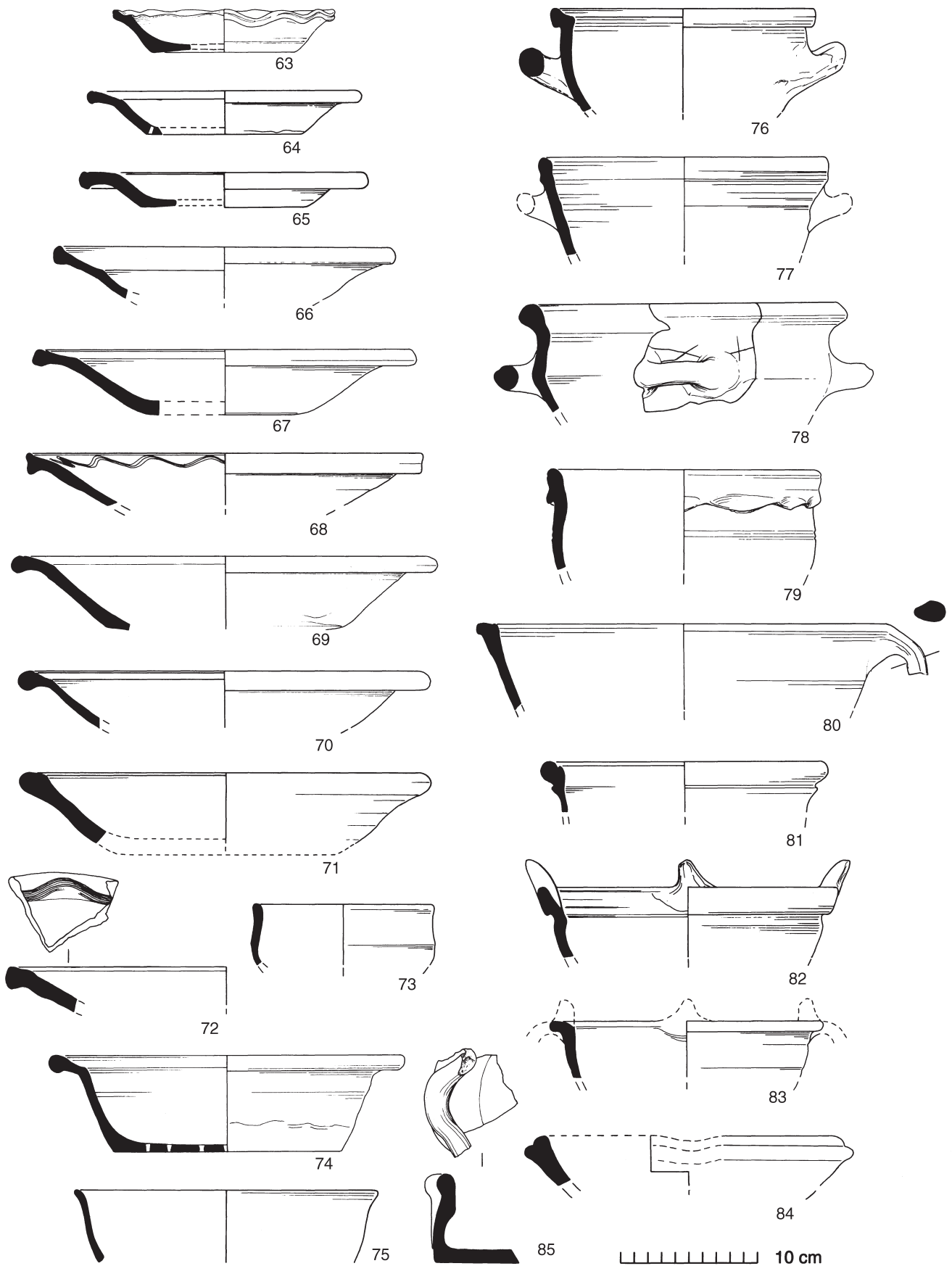

Fig 243 Stratified Group 21: MID AF15, c 1680-1700 (nos 63-85). 1:4. [Pages 344-9]

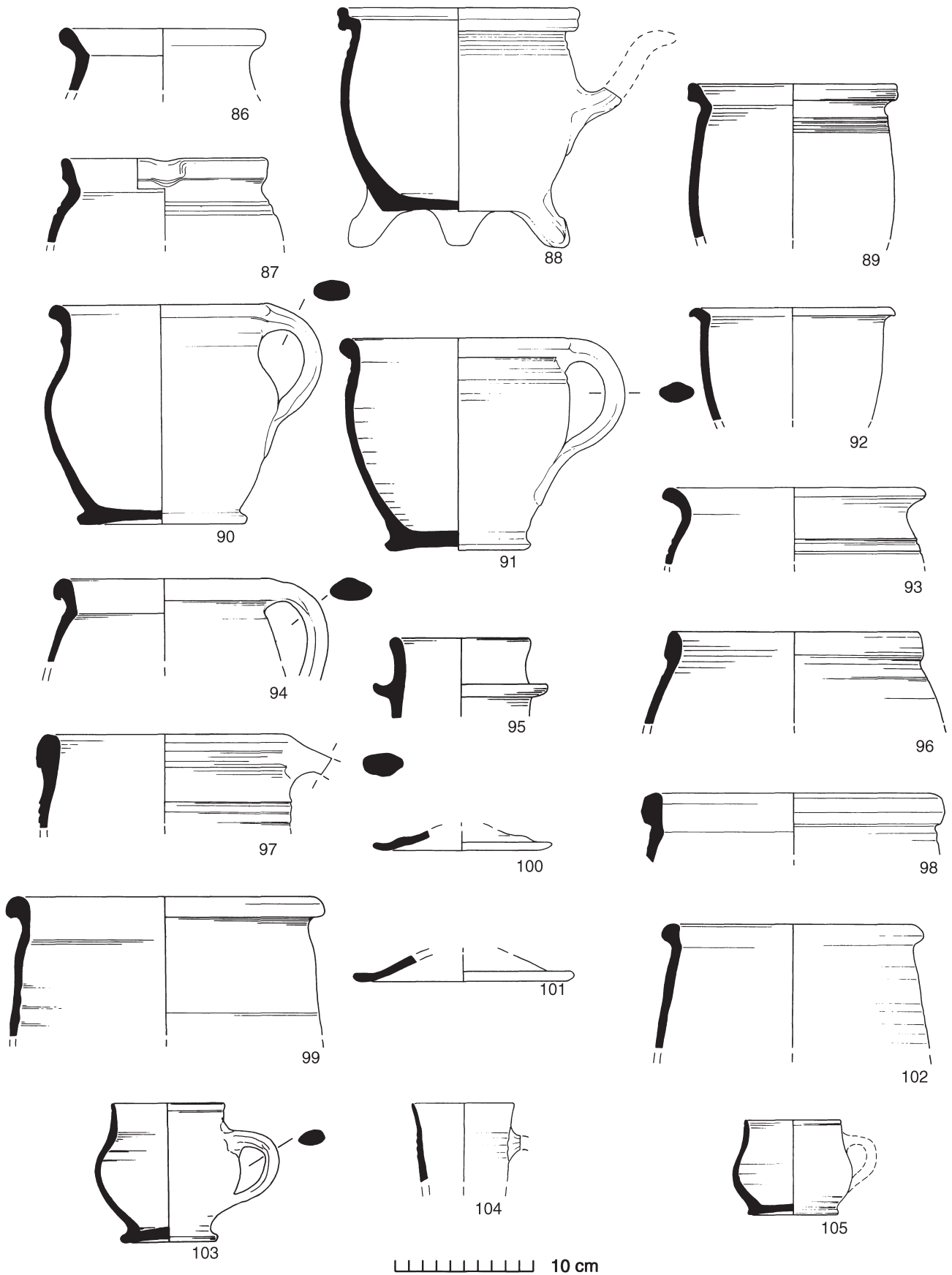

Fig 244 Stratified Group 21: MID AF15, c 1680-1700 (nos 86-105). 1:4. [Pages 344-9]

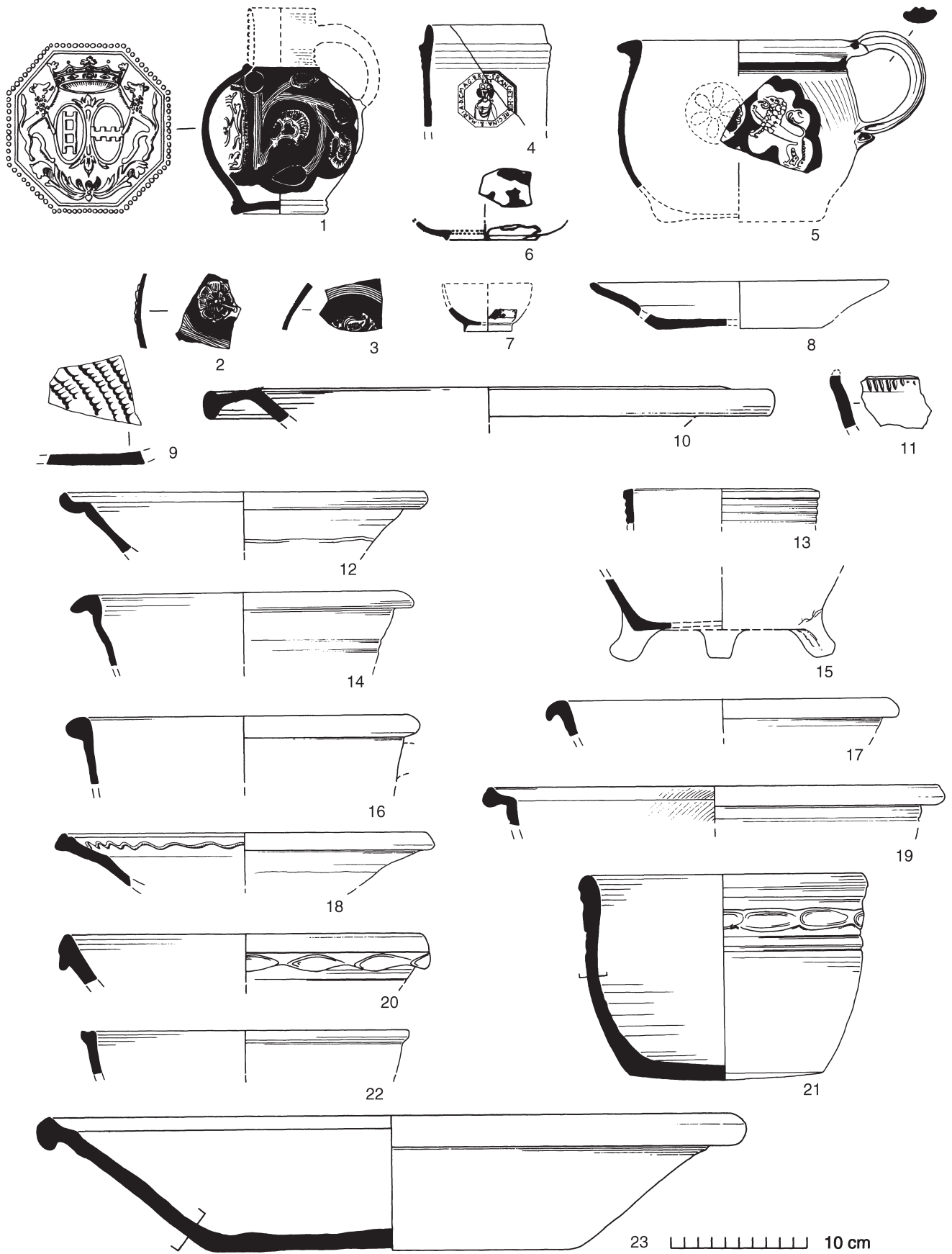

Fig 245 Stratified Group 22: LWC RF18, c 1730-40 (nos 1-23). 1:4, except medallion on no 1 at 1:2. [Pages 350-1]

**Group 22: LWC RF18** (c 1730-1740)

[Figs 245-6]

**Trench**

This feature may be an unusually late example of a robber trench. It is roughly parallel to a number of north-south early medieval robber trenches on this site and cuts an east-west robber trench (RF27; *CAR* 3, sheet 2a, fig 60). It is cut in turn by a parallel 19th-century trench-like feature (RF20) which is partly brick-lined. Alternatively RF18 and RF20 may have had some other unknown function, such as a soak-away.

The Westerwald portrait mug of Mary II (died 1694) probably dates to c 1700, while the heraldic medallion on the other Westerwald jug (Fig 245.1) is identical to that on a Westerwald plaque of 1726 illustrated by Reineking von Bock (1971, no 742). Other finds include three clay tobacco-pipe bowls of 1660-80, 1680-1720 and 1700-1740 respectively. The last pipe (*CAR* 5, fig 57.2800) and the Westerwald jug suggest a deposition date of c 1730-40.

Wares characteristic of the 18th century in Colchester, such as the press-moulded Staffordshire slipware dish (Fig 245.9) and the Chinese porcelain saucer (Fig 245.6), make their debut in this group.

Fabric	EVEs	Weight (g)	Sherds	Figs
50	-	30	1	245.9 (Staffordshire slipware)
48A	-	5	1	245.6 (Chinese porcelain)
46	-	95	11	245.7-8
45F	0.29	625	39	245.1-5
45D	-	90	2	
45C	0.23	85	5	
45	-	15	1	
42	0.74	510	19	245.10-15 (Border)
40A	0.06	105	3	245.18 (Metropolitan)
40	2.46	8,405	111	245.17, 19-23, 246.24-31
31A	-	20	1	
31	0.08	50	2	245.16 (?or red Border ware)
21A	0.16	490	10	
<b>TOTAL</b>	<b>4.02</b>	<b>10,525</b>	<b>206</b>	

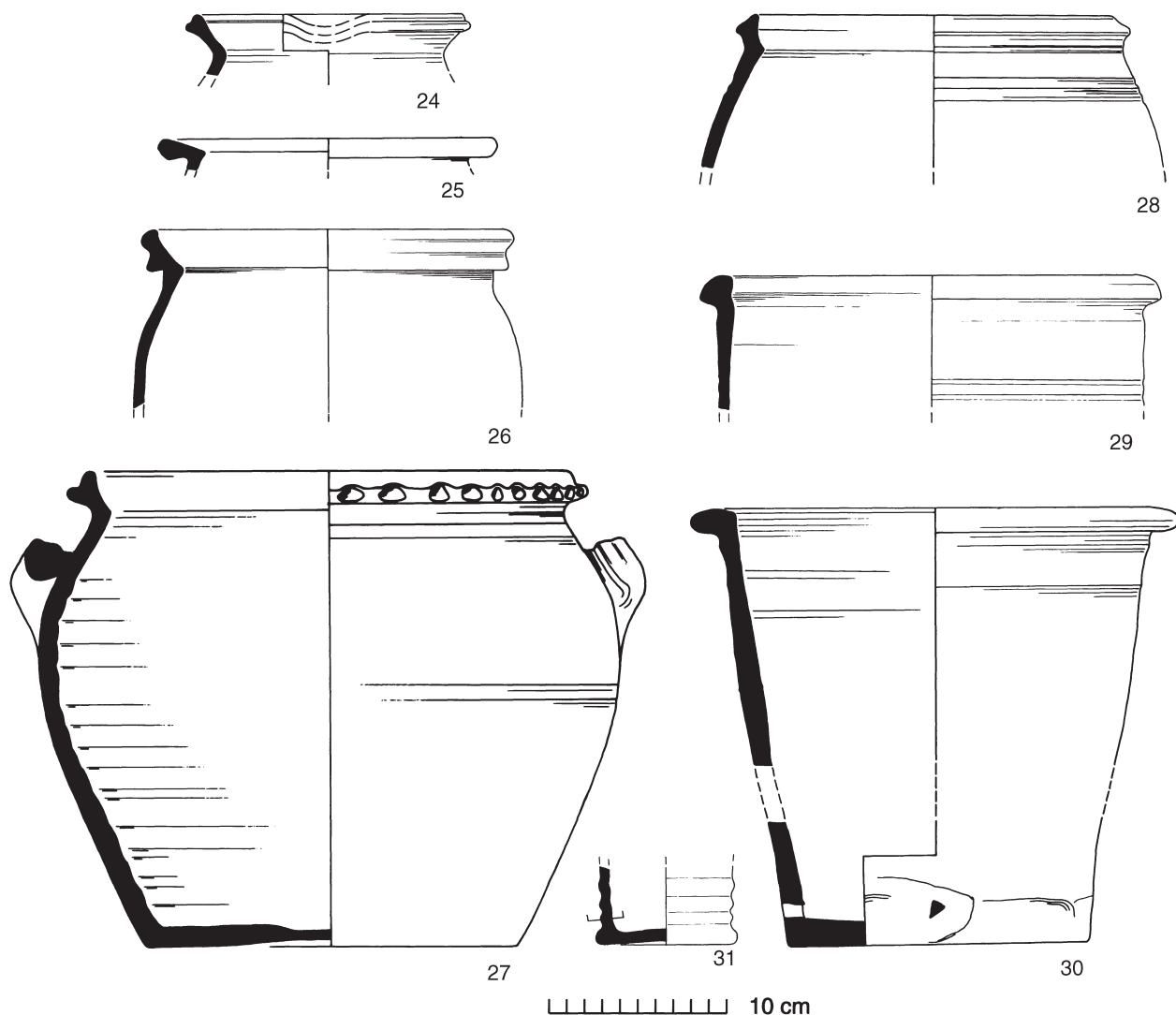

Fig 246 Stratified Group 22: LWC RF18, c 1730-40 (nos 24-31). 1:4. [Pages 350-1]

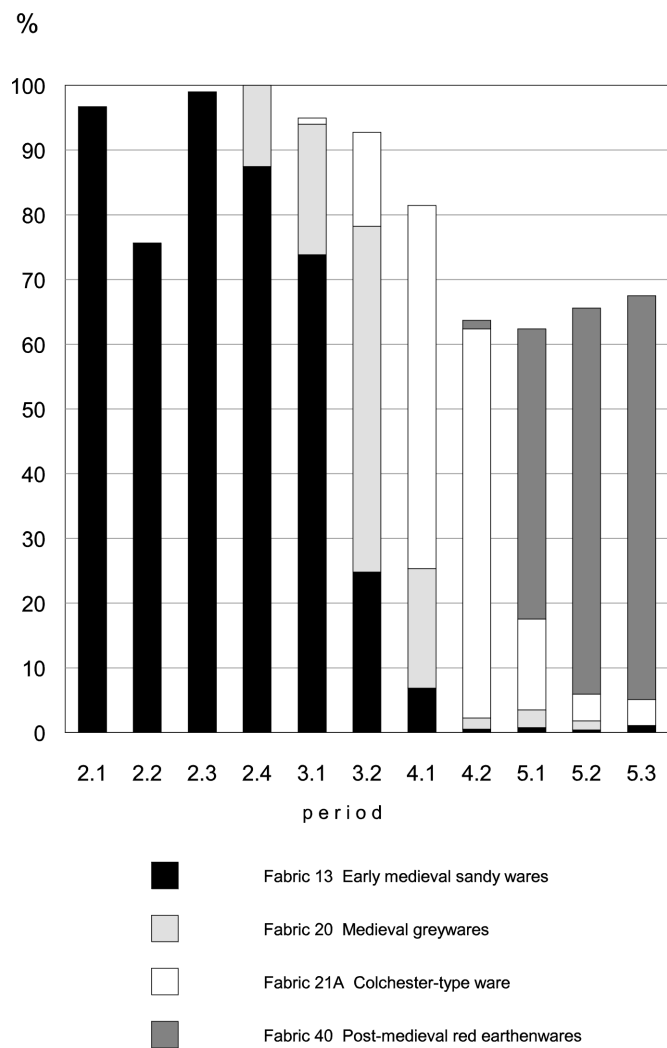

Fig 247 Major local fabrics: percentages in stratified contexts (ceramic periods). Total EVEs represented: 276.25. [Pages 353-4]

---

## Chapter 15. Conclusions

---

### Introduction

[Fig 247]

On the basis of the preceding chapters it is now possible to offer an outline sketch of the development and supply of post-Roman pottery in Colchester, before proceeding to explore certain themes in more detail and sign-posting directions which future research might take.

### Development and supply of post-Roman pottery in Colchester

#### *Anglo-Saxon*

As we have seen, the material archaeology of Anglo-Saxon Colchester is fairly sparse, and largely confined to three or four sunken huts for the period between the 5th and 7th centuries. These produced the bulk of hand-made Saxon pottery from the excavations, a few hundred sherds in total. The more common hand-made forms (cooking pots, a few bowls) compare with the more common forms at Mucking in south Essex and West Stow in Suffolk, but in no way does the Colchester assemblage for this period compare with either the magnitude or variety of the assemblages from these important Anglo-Saxon settlements. As at these sites (and at London), hand-made, sometimes burnished, sandy brickearth vessels were gradually replaced by 'vegetable'- or 'grass'-tempered vessels of similar form, which became the dominant type by the 6th or 7th century. This fabric may have continued in production, though on a small scale, even as late as the 9th century, but there is no definite evidence from Colchester for this other than the virtual absence of any other wares securely datable to this period.

The relatively small amount of early to mid-Saxon pottery from the town (Fig 4, Period 1) accords well with the general scarcity of other artefacts of this date, particularly with the dearth of finds datable to the 8th-9th centuries. The suggestion that the walled town was either deserted during this period or that its population had dropped to an all-time low is not an exaggeration (*CAR* 1, 72). However, since this suggestion was made (in 1981), at least three pottery vessels of around this date have been identified, though all but one was residual in its context. An Ipswich ware (Fabric 8) cooking pot from the High Street should date to *c* 725-850; a possible mid-Saxon 'bottle' and some oolitic-tempered vessels (Fabric 12D) might also date to the 8th-9th centuries, and if all these imported wares really are of this date then it is probable that some of the less diagnostic local wares (Fabric 1) were also still in production. The ceramic evidence thus indicates at least minimal occupation of the walled town at this date (centred, as later, on the High Street?), rather than desertion.

No ceramic types can definitely be associated with the period of Danish occupation from, perhaps, *c* 879 to 917, after which the Danes were driven from the town by the English, and it is difficult to envisage the production of local hand-made vegetable-tempered ware (Fabric 1) as late as this. There was possibly a trickle of wheel-thrown Thetford-type ware, from the Ipswich kilns, as early as this, but the bulk importation of Thetford-type wares probably coincided with the late Saxon 'urban renewal' of Colchester from perhaps the 930s onwards, and much of it probably arrived during the 11th century.

#### *Norman*

Thetford-type ware remained the dominant ceramic type in the town at least until the Norman Conquest, although the volume of pottery recovered is still relatively low despite the 419 households listed in Domesday Book. Trickle regional and foreign imports were also available at this date: bowls and cooking pots in St Neots-type ware from the south-east Midlands, glazed pitchers of Stamford ware (Lincolnshire), glazed Andenne pitchers from the Low Countries, even rarer glazed north French wares, and from the Rhineland a few red-painted Pingsdorf and blue-grey Paffrath-type vessels. Most of these types continued to arrive during the 12th and perhaps the start of the 13th centuries. Perhaps the limited pottery supply available during this early period was augmented by vessels in wood (treen) and leather, but if so we have little evidence of this.

Around 1025-50, apparently after a gap of about a century and a half, pottery production in the Colchester area started up again. In contrast to imported Thetford-type ware, the early medieval sandy ware industry (Fabric 13) produced hand-made vessels, mostly large sagging-based cooking pots. Hand-made wares seem to have been the norm in Colchester (and Essex in general) until as late as *c* 1250, when wheel-turned or thrown wares began to be made in quantity. Early medieval sandy ware vessels were apparently built-up by hand, but the rim was either made separately on a wheel or turntable and then joined to the rest of the vessel, or else a separate coil of clay was joined to the shoulder and then the whole vessel finished off on a turntable. This technique was used for the manufacture both of cooking pots and, later on, jugs, both in the local Colchester industries and in the 12th-century Heddingham industry fifteen miles to the west. The early medieval sandy ware potters produced a variant of the normal fabric which was dusted with crushed marine shell. This 'shell-dusted' ware (Fabric 13S) may have been the local answer to the true shelly ware fabrics that proliferated over much of Essex in the 12th and early 13th centuries, and probably explains the relative scarcity of these fabrics at Colchester.

Even without the discovery of the later kilns at Middleborough, the volume of early medieval sandy ware recovered (the most common post-Roman pottery from the

excavations) must reflect an increase in Colchester's population during the 11th to the 12th centuries (Fig 247). One should not, however, overlook the fact that the majority of early medieval sandy ware vessels were cooking pots at a time when probably all but the wealthiest households would have cooked in ceramic cooking pots which must have been made, used and broken in very large numbers. As metal cooking vessels became more common in later centuries, ceramic ones presumably became rarer whatever the size of the population.

#### Medieval

Medieval greyware (Fabric 20), again primarily a cooking-pot industry, dominates 13th- and 14th-century assemblages in Colchester. The disappearance of the greyware industry in the later 14th century may be attributable to the increasing availability of metal cooking vessels and competition from more aesthetically pleasing Colchester-type ware vessels. However, the large medieval-style ceramic cooking pot effectively died out at this time and was replaced by a variety of smaller Colchester-type forms. This possibly reflects changing cooking/social practices, or it could reflect the monopoly of the large cooking pot form being taken over by metal-ware vessels which have not survived in the archaeological record.

Around the middle of the 12th century, the jug form was reintroduced to the town in the shape of coarse London-type ware jugs (Fabric 36), sometimes decorated with white or red slip. This form was copied very soon afterwards by the Heddingham potters who were the main suppliers of glazed (Fabric 22) jugs to Colchester during the later 12th and 13th centuries. Heddingham jugs closely followed London styles though there were also influences from Scarborough ware (Yorkshire).

Colchester-type ware (Fabric 21A) appeared *c* 1200 but was slow to rise to prominence, a position it did not achieve until the late 14th and 15th centuries. It began as a tableware industry, mostly in the form of jugs reflecting the London style of white-slipped and green-glazed baluster jugs, although some jugs were decorated with designs in white slip. There were later, fairly strong influences from the more important central Essex industry at Mill Green near Ingatestone; and long after the decline of the Mill Green industry (*c* 1350), Colchester potters continued to produce similar slip-decorated vessels in common with many other Essex and East Anglian redware potteries. Schemes of slip decoration (eg the 'Rouen' style of pellets and geometric lines), whose origins can be traced back through Mill Green ware to London-type ware as early as *c* 1200, continued to be reproduced in Essex in ever more corrupted and debased form, even as late as *c* 1550. Colchester-type ware ended as a 'kitchenware' industry whose main products (storage jars, large bowls, etc) were robust and functional in character.

#### Post-medieval

Post-medieval redwares, whose roots, in Essex at least, may lie in the degeneration of more ancient redware industries such as Mill Green ware and Heddingham ware, first appeared during the later 15th century. By the middle of the following century, they had completely replaced the older medieval sandy ware industries such as

Colchester-type ware, and they remained the dominant Essex ware until the late 18th or early 19th century. A few redware potteries survived even as late as the 1940s, but the products of Staffordshire and other industrialised potteries had already overwhelmed the market for pottery in Essex at least a century earlier.

#### English 'imports' as evidence for trade and cultural links

In the seven centuries between *c* 1050 and *c* 1750, the vast bulk of pottery supplied to Colchester was produced within a radius of four miles or so. Until perhaps the 15th century (Period 4.1), locally produced pottery appears, from the excavated assemblages, to have satisfied around 90% or more of the town's ceramic needs (Fig 247). In the post-medieval period (*c* 1500-1750), locally produced wares still dominated the market but now supplied only two-thirds of the town's requirements, the remaining third having been yielded up to a mixture of foreign and non-local English imports in roughly equal measure. Possibly the figure for 'local' wares is even lower than two-thirds, as it is much more difficult to demonstrate that during this period the bulk of pottery was 'locally' produced as opposed to Essex-produced. If there were more assemblages of the late 18th and 19th centuries, the proportion of locally or Essex-produced wares in circulation would be seen to drop dramatically.

The excavated pottery has something to say about Colchester's trade links during the post-Roman period, although it should not be considered wholly in isolation from other classes of artefact or existing documentation. For the early to mid-Saxon period (*c* 450-850) there is not a great deal to be said. Although Ipswich ware (*c* 725-850) is no longer absent from the town, its presence is almost negligible despite the fact that Ipswich lies only eighteen miles distant. The suggestion therefore that political differences between the kingdoms of East Anglia and Essex might have affected the trade of Ipswich ware to Essex thus remains plausible (CAR 1, 23). Conversely, the presence of at least seven oolitic-tempered vessels (Fabric 12D), possibly from Northamptonshire, could be viewed as evidence of stronger trade links with the Saxon kingdom of Mercia. Rare Merovingian or Frankish wares imported during this period hint at Continental trade, but even if it was direct, pottery was not an important part of it.

The quantity of Thetford-type wares in 10th- and 11th-century contexts must demonstrate trade with the important Saxon port of Ipswich where much of this ware was produced, though a few pieces from Colchester might have come from Norfolk sources. Other East Anglian pottery types, ie Stamford (Lincolnshire) and St Neots (?Cambridgeshire), are also represented at this time, and at least a few London-area products (Fabric 12C, Fabric 36) were reaching the town in the 11th and 12th centuries.

Except in the small and perhaps biased Period 2.2 sample (*c* 1100-25), non-local English wares never comprised more than 5-7% of the excavated medieval assemblages (Periods 3.1 and 3.2). Glazed Essex wares, principally Heddingham and Mill Green jugs, formed the bulk of this total. The distribution of Heddingham ware shows that Cambridgeshire



as much as north Essex formed a large part of its market during the 13th and 14th centuries. Finds of shell-dusted early medieval ware in Cambridgeshire, possibly but not definitely from Colchester, hint at even earlier trade/cultural links between these adjoining counties. Later similarities between slip-decorated Colchester-type ware and Cambridgeshire redwares highlight the degree of ceramic and perhaps cultural continuity in these areas. These links may have been influenced by Colchester's role as an important medieval textile town with its attendant need for raw materials (wool, fuller's earth, etc) drawn from a wide catchment area and met via an established network of regional markets and fairs.

Scarborough and Beverley in Yorkshire mark the most distant medieval English pottery sources to be represented at Colchester, but only by a few vessels which arrived presumably in the course of coastal trade.

In the post-medieval period, the supply of non-local English wares to the town increased gradually from around 11% (Period 4.2) to nearly 18% (Period 5.3). This supply was almost certainly influenced by the town's role as one of the major textile towns in the country, and its heavy dependence on London to market the cloth and keep the town supplied with raw materials and imported luxuries. Whether by road or sea (both were equally used), London wares (tin-glazed, stoneware, etc), Surrey Border wares and even more unexpected wares (eg North Devon gravel-tempered ware) were almost certainly funnelled through London. From c 1675, however, Staffordshire wares arrived direct.

### Foreign imports and trade

Imported foreign wares were numerically insignificant in medieval Colchester and, until perhaps the late 14th century, never formed more than around 0.5% of the assemblage. From then on, however, there was a marked increase: imports formed 17% of the Period 4.1 assemblage rising to a peak of 25% in Period 4.2 (c 1450-1550/80), but dropping to 15% by Period 5.3 (c 1680/1700 onwards).

Despite some direct but comparatively late trade with Gascony (for wine), French wares never formed more than 1-3% of any period assemblage and usually formed less than this. In common with most east coast ports, Rhenish and Low Countries wares were always the dominant foreign wares in medieval and post-medieval Colchester. Rhenish or German wares, mostly stoneware drinking vessels, formed the bulk of this trade: 9% in Period 4.1 (mostly Siegburg stoneware), 23% in Period 4.2 (of which 21% Raeren stoneware), and 8%, 12% and 7% in Periods 5.1, 5.2 and 5.3 respectively (mostly Cologne/Frechen stoneware). However, this trade would have come via the Low Countries, mostly in Dutch shipping. The single and almost certainly highly-prized vessel in Gothic stoneware, from eastern Germany, could represent a different trade route, perhaps the only tangible evidence of Colchester's direct Baltic trade in the late 14th and 15th centuries. Low Countries wares (mostly red earthenware cooking pots) comprised between 2% and 5% of the 15th- to 16th-century assemblages, reaching a peak of 8% in Period 5.3. The post-medieval figures for Low Countries wares are probably an under-

estimate as tin-glazed wares from here have not been quantified separately from the English wares.

The volume of imported wares in the late 15th and 16th centuries, which was never again equalled, bears out two independent observations. Firstly, that the period of maximum importation coincided with the town's period of maximum prosperity (c 1525) when Colchester ranked as the ninth wealthiest town in England (see above p 19). Secondly, the quantities of Rhenish stonewares from the excavations, the largest class of foreign imports, bear out documentary sources which indicate that Colchester was the largest single recipient of stoneware cargoes exported on from London in the later 16th century (see p 277). Evidently prosperity and Rhenish stonewares (associated with drinking) were closely interlinked and Colchester took as much of the latter as it could get, whatever the sources.

### The broader picture

On the whole, Colchester's post-Roman ceramic assemblage reflects the general picture of ceramic development seen over most of south-east England. Its chief importance must surely lie in the contribution it makes towards the study of local medieval and post-medieval pottery in Essex and East Anglia. In terms of imported wares, Colchester conforms with the patterns seen at other east coast ports, which show an emphasis on Rhenish and Low Countries imports as opposed to the south coast emphasis on French and Mediterranean wares (Brooks & Hodges 1983).

The character of the imported wares and the percentages present compare fairly closely with London and Norwich, and obviously with Harwich only fifteen miles away (Walker 1990a). The similarities with London and Norwich are hardly surprising, given that Colchester is equidistant from the two, though obviously it would be a mistake to suggest that Colchester was ever in the same economic league. Throughout the medieval and later period, Colchester was influenced by the proximity of London and East Anglia; and while this dual influence was undoubtedly imprinted on the character of its ceramics, the pull of East Anglia seems always to have been just that bit greater.

### Recommendations for future work

It is hoped that the publication of this report will set our understanding of the area's post-Roman ceramics on a new and firmer footing, so that future aspects of research might be more focussed and objective. Many old questions still remain to be satisfactorily answered and there are many new questions raised by this survey, too many to be addressed here, but a few of the more important questions and some recommendations can be highlighted.

The start and end dates for all Colchester's local wares should be more closely defined as and when new evidence comes to light. The Saxon period in Colchester still remains the haziest period as far as ceramic knowledge is concerned, particularly for the 8th-9th centuries. Perhaps significant

ceramic assemblages for these centuries never will be found (particularly if the town was almost deserted), but it is important that they should be recognised if and when they are found. There are similar though less extreme *lacunae* in our knowledge of late 13th- and 14th-century assemblages from the town, and the second half of the 16th century is also only very patchily represented.

Some aspects of the medieval Colchester-type ware industry need further investigation, both in terms of specific details and in the wider context of the industry. The physical appearance of the earliest Colchester-type forms is still only poorly understood as the earliest material recovered is so fragmentary. The recognition and publication of more complete profiles of the earliest Colchester-type ware forms should be a priority, as these should clarify questions on the industry's origins and influences.

Other questions remain on the source(s) of Colchester-type ware and its relationship to other Essex and 'East Anglian' redware industries. Was Colchester-type ware produced at other local production sites besides the two already located? To what extent can Colchester-type ware be distinguished from other East Anglian redwares, or are they all just variations on a theme? The idea or definition of an East Anglian redware 'tradition' also requires much more detailed investigation, since the tradition of slip-painted decoration was apparently more popular in some counties than others and was not by any means strictly confined to East Anglia.

The lack of published information on (post-Saxon) medieval and later pottery from nearby Cambridgeshire and Suffolk in particular remains a serious obstacle to comparative studies within the Essex-East Anglian region. The publication of assemblages from Ipswich and Cambridge would undoubtedly assist in any future attempts at a regional overview.

Closer to home, the publication of the Heddingham kilns must be seen as a matter of considerable urgency and importance. It is also essential that the chronology of this widely traded regional ware should be more properly understood, as this will have dating implications for many smaller industries in the region and many other aspects of medieval archaeology.

There are almost certainly many more pottery-production sites in Essex than those currently known. The location of these by means of documentary research and fieldwork would benefit from greater co-operation between specialists and a more methodical county-wide approach. Likewise, the publication of the many as yet unpublished kiln-site collections housed in county museums would greatly aid questions of fabric source and attribution which cannot be answered by the publication of domestic assemblages alone.

It is unlikely that such a large and varied ceramic collection as that from Colchester will be available from anywhere in northern Essex for many years to come, and while the publication of this is a fruition of a kind, there are still plenty of directions in which future work might grow.

# Appendix 1.

## Concordance of illustrated pottery

The concordance gives the original catalogue number (second column), the ceramic phase or stratified group (SG) (third column), and the context (fourth column) for each illustrated vessel or sherd. (The original catalogue numbers are needed to identify the illustrated material in the pottery store and in the archival data, all of which are in Colchester Museum.)

### Saxon 'brickearth' wares

#### Fabric 97

Fig 5

1	88	-	LWC H39
2	87	-	LWC HF56
3	430	-	BKC T221

### Vegetable-tempered ware

#### Fabric 1

Fig 6

1	873	SG 2	1.81 BF4
2	924	1	1.81 KF12
3	870	SG 2	1.81 BF4
4	923	1	1.81 KF12
5	939	-	LWC E53
6	867	-	1.81 CF4

### Ipswich ware

#### Fabric 8

Fig 7

1	1418	2.2-3	CPS F116
---	------	-------	----------

### ?Mid-Saxon wheel-turned bottle

#### Fabric 8V

Fig 8

1	1419	2	CPS F46
---	------	---	---------

### Thetford-type wares

#### Fabric 9

Fig 9

1	1645	-	CM 402.35 (30-31 High Street)
2	947	-	LWC AF30
3	1417	SG 4	LWC NF2102
4	276	-	COC F90
5	860	-	1.81 AF34
6	275	-	COC F90
7	954	-	SPT L48
8	212	-	LWC BF97
9	952	-	LWC AF89+F31
10	700	-	1.81 GF661
11	1320	-	LWC JF63
12	1644	3.1	LWC JF51
13	658	2.2-3	CPS F112+F114
14	1318	2.2-3	CPS F116
15	1646	-	CM 48.1973 (St Nicholas' Church 1955)

Fig 10

16	650	2	CPS F45
17	1317	2.2-3	CPS F112
18	1421	2	CPS F46
19	704	-	1.81 GF3458

### St Neots-type ware

#### Fabric 10

Fig 11

1	514	5.2	LWC GF62
2	1175	2.2-3	CPS F83
3	863	-	1.81 AF42

4	515	2.2	LWC GF232
---	-----	-----	-----------

### Stamford ware

#### Fabric 11A

Fig 12

1	381	2.2	LWC GF232+GF62
2	382	5.2	LWC GF62
3	1150	-	LWC EF16

### Shelly wares without sand

#### Fabric 12A

Fig 13

1	1422	-	1.81 HF171
2	405	-	COC F90

### Slightly sandy shelly wares

#### Fabric 12B

Fig 14

1	304	-	COC F112
2	441	3.2	MID CL164
3	1423	-	MSC L31
4	1424	3.1	COC F265

### Sandy shelly wares

#### Fabric 12C

Fig 15

1	1390	SG 4	LWC NF2101
2	903	SG 5	1.81 HF365
3	1426	-	LWC K61
4	1427	3.2	MSC L15
5	1428	-	LWC JF170

### Oolitic wares

#### Fabric 12D

Fig 16

1	869	-	1.81 BF810+F108+L375
2	912	-	1.81 DF43
3	205	-	LWC BF44
4	545	-	1.81 EF185
5	674	-	CPS L87

### Early medieval sandy wares

#### Fabric 13

Fig 20

1	1429	SG 3	CPS F106
2	1381	SG 4	LWC NF2101

#### Fabric 13S

3	574	5.2	LWC CF18
4	584	-	1.81 G294

#### Fabric 13

5	587	-	IRB F62
6	301	-	LWC K401

#### Fabric 13S

7	302	-	LWC K401
8	12	2.3	LWC GF231

#### Fabric 13

Fig 22

9	386	2.2	LWC GF237
---	-----	-----	-----------

#### Fabric 13T

10	685	3.1	1.81 GF478
----	-----	-----	------------

#### Fabric 13

11	1462	-	MID XF349 (kilns)
12	904	-	1.81 HL3 (probably derived from SG 5)
13	929	-	GBS AF80+ F85
14	247	-	COC F7
15	694	-	1.81 GF60
16	1385	SG 4	LWC NF2101

#### Fabric 13S

17	885	SG 5	1.81 HF365
----	-----	------	------------

### Fabric 13T

Fig 23

18	684	SG 6	1.81 GF163
----	-----	------	------------

### Fabric 13

19	394	-	MID CF480 (kilns)
20	1296	SG 6	1.81 GF163

### Fabric 13S

21	585	-	1.81 G294
22	693	-	1.81 GF60
23	432	3.2	MID CL87
24	703	-	1.81 GF3458

### Fabric 13

25	898	-	1.81 HF418
26	353	3.1	COC F264
27	211	-	LWC BF74
28	226	-	LWC B93
29	387	2.2	LWC GF237

Fig 24

30	887	SG 5	1.81 HF365
----	-----	------	------------

### Fabric 13T

31	297	-	LWC K408
----	-----	---	----------

### Fabric 13

32	385	3	LWC GF156
----	-----	---	-----------

### Fabric 13T

33	933	2	CPS L68
----	-----	---	---------

### Fabric 13

34	1341	-	MID XF12 (kilns)
35	406	-	MID CF16

### Fabric 13T

36	921	-	1.81 DL1437
----	-----	---	-------------

### Fabric 13

Fig 25

37	902	-	1.81 HL3
38	1310	SG 6	1.81 GF163
39	245	3.1	MSC L26
40	438	3.2	MID CL127
41	651	2	CPS F46
42	891	SG 5	1.81 HF365
43	944	3.1	LWC JF135
44	414	3.2	MID CF169

Fig 26

45	51	-	LWC L116
----	----	---	----------

### Fabric 13T

46	686	3.1	1.81 GF478
----	-----	-----	------------

### Fabric 13

47	897	-	1.81 HF418
48	1028	-	BUC C212
49	1354	-	MID XF349 (kilns)
50	1539	SG 6	1.81 GF163
51	13	3.1	1.81 GF393

### Fabric 13T

52	396	3.1	MID CF471 (from potter's hut)
----	-----	-----	-------------------------------

### Fabric 13

53	1538	2.4	LWC GF88
----	------	-----	----------

Fig 30

54	453	-	IRB 84 (St John's church, c 1095)
55	683	SG 6	1.81 GF163

### Fabric 13S

56	575	5.2	LWC CF18
----	-----	-----	----------

### Fabric 13

57	48	2	LWC LF260
58	894	SG 5	1.81 HF365

### Fabric 13S

59	701	-	1.81 GF982
----	-----	---	------------

### Fabric 13

60	690	-	1.81 GF60
61	689	3.1	1.81 GF450
62	691	-	1.81 GF60
63	899	-	1.81 HF418

Early medieval sandy ware (Fabric 13)

64 692 - 1.81 GF60  
**Fabric 13T**  
 65 511 - MID C1438

**Fabric 13**  
*Fig 31*  
 66 431 3.2 MID CL87 (probably derived from kilns)

**Fabric 13T**  
 67 1470 3.1 MID CF471

**Fabric 13**  
 68 274 - COC F90  
 69 655 3/4.1 CPS F98

**Fabric 13T**  
 70 437 3.2 MID CL122

**Fabric 13**  
 71 1472 3.1 MID CF471  
 72 688 2.2-4 1.81 GF376

*Fig 32*  
 73 907 - 1.81 JF124  
 74 656A 2.2-3 CPS F112  
 75 404 - LWC G167  
 76 892 SG 5 1.81 HF365  
 77 1456 SG 5 1.81 HF365  
 78 398 - MID CF490

**Fabric 13T**  
 79 696 2.4 1.81 GF165  
 80 1471 3.1 1.81 GF293

**Fabric 13**  
 81 1476 3.2 MID CL127  
 82 1473 2 MSC L30  
 83 1527 - 1.81 MF300  
 84 1469 3.1 LWC CF89  
 85 705 - 1.81 G51  
 86 1529 - LWC C35  
 87 1528 - MID EL424

Early medieval sandy ware  
 Middleborough kilns

**Fabric 13**  
*Fig 33*  
 1 524 - MID XF12  
 2 1345 - MID XF497  
 3 1341 - MID XF12  
 4 522 - MID XF11  
 5 1335 - MID XF13  
 6 1474 - MID XF354  
 7 1462 - MID XF349  
 8 1461 - MID XF349  
 9 1362 - MID XF349  
 10 394 - MID CF480 (probably derived from kilns)  
 11 1459 - MID XF354  
 12 1363 - MID XF349  
 13 1460 - MID XF13

*Fig 34*  
 14 1366 - MID XF349  
 15 1321 - MID XF13  
 16 1369 - MID XF349  
 17 1368 - MID XF349  
 18 1330 - MID XF13  
 19 1367 - MID XF349  
 20 1236 - MID XF349  
 21 1334 - MID XF11  
 22 1331 - MID XF13  
 23 1361 - MID XF349  
 24 1374 - MID XF349  
 25 1468 - MID XF349  
 26 1360 - MID XF349  
 27 1333 - MID XF13  
 28 1467 - MID XF349  
 29 1343 - MID XF497  
 30 1372 - MID XF349  
 31 1346 - MID XF497

*Fig 35*  
 32 1477 - MID XF349  
 33 1478 - MID XF349  
 34 1479 - MID XF349  
 35 1480 - MID XF349  
 36 1481 - MID XF349  
 37 1482 - MID XF349  
 38 1483 - MID XF349  
 39 1484 - MID XF349  
 40 1485 - MID XF349  
 41 1486 - MID XF354  
 42 1487 - MID XF354  
 43 1488 - MID XF354

44 1489 - MID XF354  
 45 1490 - MID XF354  
 46 1500 - MID XF11  
 47 1501 - MID XF11  
 48 1502 - MID XF11  
 49 1503 - MID XF11  
 50 1504 - MID XF11  
 51 1505 - MID XF11  
 52 1506 - MID XF12  
 53 1507 - MID XF12  
 54 1508 - MID XF12  
 55 1509 - MID XF12  
 56 1510 - MID XF12  
 57 1511 - MID XF12  
 58 1512 - MID XF12  
 59 1513 - MID XF12  
 60 1514 - MID XF12  
 61 1515 - MID XF13  
 62 1516 - MID XF13  
 63 1517 - MID XF13  
 64 1518 - MID XF13  
 65 1519 - MID XF13  
 66 1520 - MID XF13  
 67 1521 - MID XF13  
 68 1491 - MID XF371  
 69 1492 - MID XF371  
 70 1493 - MID XF371  
 71 1494 - MID XF371  
 72 1495 - MID XF371  
 73 1496 - MID XF371  
 74 1497 - MID XF371  
 75 1498 - MID XF371  
 76 1499 - MID XF371  
 77 1522 - MID XF497  
 78 1523 - MID XF497  
 79 1524 - MID XF497  
 80 1525 - MID XF497  
 81 1526 - MID XF497

*Fig 36*  
 82 1354 - MID XF349  
 83 393 - MID XF371  
 84 1339 - MID XF12  
 85 523 - MID XF11  
 86 1463 - MID XF12  
 87 1355 - MID XF349  
 88 1326 - MID XF13  
 89 1353 - MID XF354  
 90 1465 - MID XF349  
 91 392A - MID XF349  
 92 392B - MID XF349

*Fig 37*  
 93 1358 - MID XF349  
 94 1357 - MID XF349  
 95 1344 - MID XF497  
 96 1342 - MID XF497  
 97 1359 - MID XF349  
 98 1466 - MID XF354  
 99 1352 - MID XF354  
 100 1475 - MID XF354

*Fig 39*  
 101 949 - MID XF349  
 102 948 - MID XF349  
 103 1464 - MID XF349  
 104 1357 - MID XF11  
 105 1371 - MID XF349  
 106 1356 - MID XF349  
 107 1370 - MID XF349  
 108 1351 - MID XF371  
 109 395 - MID CF480 (probably derived from kilns)

*Fig 41*  
 110 1338 - MID XF12+F13  
 111 1347 - MID XF371  
 112 1350 - MID XF371  
 113 1348 - MID XF371  
 114 1336 - MID XF11  
 115 1325 - MID XF13  
 116 1332 - MID XF13  
 117 1340 - MID XF12

London-type ware

**Fabric 36**  
*Fig 43*  
 1 590 3 LWC CF49  
 2 1324 - 1.81 E314  
 3 320 SG 7 COC F213  
 4 844 - 1.81 EF278  
 5 207 SG11 LWC BF45  
 6 1312 3/4.1 CPS F69

Scarborough ware

**Fabric 24**  
*Fig 45*  
 1 649 - LWC J1  
 2 697 - 1.81 GF262  
 3 623 3.1 LWC CF88  
 4 699 - 1.81 GF484  
 5 676 - CPS 211

Other Yorkshire wares

**Fabric 24X**  
*Fig 46*  
 1 565 - LWC BF5  
 2 1156 - LWC L397

Hedingham ware

**Fabric 22**  
*Fig 49*  
 1 687 SG 6 1.81 GF163+F478+1.81 DL866  
 2 321 SG 7 COC F213  
 3 295 - LWC KF22  
 4 1672 - CM 5606.27 (Colchester)  
 5 647 - LWC JF86  
 6 1313 - LWC BF5  
 7 648 3.1 LWC JF128  
 8 1671 - CM 118B 1935/10 (GPO, Head Street)  
 9 1664 - 1.81 EF108  
 10 1677 - LWC CF35  
 11 930 - GBS AL1  
 12 1314 3.1 COC F264  
 13 1315 - COC F30

*Fig 50*  
 14 812 - 1.81 EF2  
 15 702 - 1.81 GF1063  
 16 1322 - MID F580  
 17 1622 - CM 2834.13 ('Hippodrome', High Street)  
 18 831 - 1.81 EF123  
 19 199 - LWC BF18  
 20 45 SG 4 LWC NF2105  
 21 1321 - MID CL211  
 22 200 - LWC BF18  
 23 429 3.2 MID CL87

*Fig 51*  
 24 323 3.1 COC F224  
 25 1676 - LWC A41  
 26 663 3/4.1 CPS L22  
 27 1678 - LWC C130  
 28 1633 - LWC CF7  
 29 1632 3.1 LWC CF88  
 30 1311 3.2 CPS L44

Medieval greyware

**Fabric 20**  
*Fig 58*  
 1 819 - 1.81 EF8  
 2 322 3.1 COC F219  
 3 391 - MID CF337  
 4 326 - COC F339  
 5 3 - LWC SF16  
 6 636 - LWC C127  
 7 436 3.2 MID CL122  
 8 418 - MID CF219  
 9 644 - LWC JF88

*Fig 59*  
 10 363 3.2 COC L8  
 11 1705 - CM 1172.1931 (Sir Isaac's Walk)  
 12 1608 - LWC AF51  
 13 399 - LWC PF14  
 14 344 5.2 COC L30  
 15 11 - 1.81 EF131  
 16 1019 - MID EL400/CF487  
 17 246 - MSC 145

*Fig 60*  
 18 1534 3.1 COC F146  
 19 52 - LWC L201  
 20 46 3.1 LWC LF88  
 21 203 - LWC BF30  
 22 1537 - 1.81 HF118  
 23 380 - LWC GF55  
 24 671 3.2 CPS L48  
 25 666 3.2 CPS L48  
 26 668 3.2 CPS L48

<b>Fig 61</b>			
27	591	?	LWC CF493
28	439	-	MID CL148
29	624	3.1	LWC CF88
30	1551	-	LWC JF96
31	440	-	MID CL162+L163
32	706	SG 4	LWC NF2105
<b>Fig 62</b>			
33	435	3.1	MID CL114
34	848	-	1.81 E505
35	512	-	MID C1458
36	1544	-	1.81 EF94
37	1530	4.1	COC F20
38	303	4.1	COC F104
39	707	3.2	LWC NL4
<b>Fig 64</b>			
40	1656	-	CM 992.1905 (High Street)
41	1449	SG 7	COC F213
42	273	4.1	COC F89
43	408	-	1.81 JF42
<b>Fig 65</b>			
44	646	3.1	LWC JF16
45	1531	4.1	COC F20
46	210	-	LWC BF64
47	1557	3.2	MID CF306
48	1532	5.2	COC F65
49	1657	-	CM 139.1899 (Town Hall)
50	1533	3.1	COC F146
51	1659	-	CM 475.1903 (Colchester)
52	1658	-	CM 49.1943 (Frinton)
<b>Fig 66</b>			
53	1552	-	1.81 HF176
54	1542	-	LWC A10
55	670	3.2	CPS L48
56	1535	4.1	COC L84
57	1547	-	X37 (49, North Hill)
58	1548	-	1.81 EF300
59	1546	-	LWC BF22
60	324	3.1	COC F262
61	1706	-	40.86 F285
62	50	-	LWC L115
63	1543	-	LWC A10
64	1545	4.1	COC L76
65	654	3/4.1	CPS F69
66	653	3/4.1	CPS F69
67	1563	-	BKC D86
68	1550	-	MID CL24
69	1549	-	MID CF135
70	1536	4.1	COC L76
<b>Colchester-type ware</b>			
<b>Fabric 21A</b>			
<b>Fig 71</b>			
1	1692	-	CM 133.1980 (Calver Collection unprovenanced)
2	478	-	LWC G173
3	516	3.1	MID EF972+F969
4	1616	-	CM unaccessioned (High Street, June 1944, M&S)
5	459	-	MID CF255
6	1582	4.2/5.2	CPS L4
7	1581	-	CPS L15 +L8
8	1624	-	CM 149.35 (Culver Street)
9	1617	-	CM 91.1898 (unprovenanced, ?Town Hall)
10	665	3/4.1	CPS L22/L57
<b>Fig 73</b>			
11	775	-	MID AF698
12	354	SG 8	COC F212+L129
13	319	SG 8	COC F212
14	1031	-	LWC U/S (SF.4141)
15	461	3.2	MID EF830 (buried before hearth)
<b>Fig 74</b>			
16	1691	-	CM 253.2 (60 & 62, Hythe Hill)
17	166	-	LWC BF5
18	1620	-	CM 501.34 (GPO, Head Street)
19	1623	-	CM 138.1899 (Town Hall)
20	1618	-	CM 154.1899/4 (purchased 1899, ?Town Hall)
21	202	-	LWC BF23
22	1574	5.2	LWC NF7
23	1701	-	CM 137.1899 (Town Hall)
<b>Fig 75</b>			
24	481	-	MID AF64
25	1619	-	CM 232.1974 (852) (Barclay's bank, Queen Street)
26	486	-	BKC E125
27	484	4.1	COC L309
28	496	-	LWC AF33
29	488	-	LWC LF87
30	446	-	1.81 EF133
<b>Fig 78</b>			
31	445	-	LWC AF33
32	1697	3.26?	CM 521 (?Colchester, donated by P G Laver)
33	1587	-	MID AF52
34	444	-	1.81 BF96
35	1636	-	LWC AF16
36	171	-	LWC BF6
<b>Fig 79</b>			
37	1621	-	CM 39.1897
38	1648	-	CM 2663.1913 (Head Street)
39	603	SG 16	LWC CF77
40	1704	-	1.81 HF157
41	1712	-	BM 1867.10-14.1 (found Ardleigh)
42	473	-	1.81 EF106
43	1626	-	CM 418.37 (River Colne, Colchester)
44	1655	-	CM 111.35 (GPO, Head Street)
45	1625	-	CM 2001.10 (Bocking)
46	711	-	MID AF14
47	1699	-	CM 154.1899 (unprovenanced, ?Town Hall)
<b>Fig 82</b>			
48	64	-	BKC JF21
49	1588	-	LWC SF9
50	1710	-	40.86 F276
51	846	-	1.81 EF1000
52	1568	-	1.81 W1
53	1567	-	COC 69
54	497	-	LWC A122
55	1565	-	LWC JF40+F86
56	1435	SG 8	COC F212
57	1436	3.2	COC L113
58	1436	3.2	COC L113
59	457	-	LWC AF119
60	454	3.1	COC F146+L113
<b>Fig 83</b>			
61	470	-	1.81 EF2
62	467	SG 12	LWC CF65
63	1560	-	1.81 E1
64	521	-	MID EL487
65	370	3.1	MSC L10+L26
66	1289	SG 11	LWC BF45
67	1575	-	MID C1410
68	1576	-	LWC NF30
69	1566	3.1	LWC CF88
70	1569	3.2	COC L8
71	163	-	LWC AF31
72	490	-	LWC DF101
<b>Fig 84</b>			
73	698	3.1	1.81 GF293
74	945	4	MSC F53 (kiln-site)
75	443	-	1.81 AF6
76	153	-	LWC AF16
77	1187	SG 9	LWC MF22/F53
78	487	-	LWC LF87
<b>Fig 85</b>			
79	835	-	1.81 EF133
80	504	4.2	LWC LF100
81	1580	-	MID AF401
82	483	-	CSC F3
83	911	-	1.81 J333
<b>Fig 86</b>			
84	407	-	MID CF87
85	447	-	1.81 EF7
<b>Fig 87</b>			
86	489	4.2/5.2	LWC NF27
87	479	-	CSC F3
88	442	-	1.81 A7
89	482	-	CSC F2
90	475	-	1.81 BF96
91	472	-	1.81 BF96
92	468	-	1.81 BF96
<b>Fig 88</b>			
93	884	-	1.81 HF176
94	476	4.2/5.2	LWC NF27
95	150	4.2	LWC AF15
96	450	4.2/5.2	LWC NF27
97	850	-	1.81 AF4
98	883	SG 15	1.81 HF158
99	463	SG 12	LWC CF65
100	508	-	MID CF135
101	1173	-	1.81 A47
<b>Fig 89</b>			
102	626	-	LWC CF96
103	480	-	LWC Q15
104	510	-	MRC 24
105	1571	5.2	COC L30
106	1698	-	CM 1430.07 (?Colchester, donated by H Laver)
107	1634	-	MID AL3
108	452	-	LWC Q14
109	493	-	LWC LF14
110	652	3/4.1	CPS F69
<b>Fig 90</b>			
111	661	4.2/5.2	CPS F167
112	627	-	LWC C7
113	829	-	1.81 EF90
114	477	?	LWC AF16
115	1638	-	LWC GF167
116	1702	-	CM 3.30 (Wyre Street pit)
117	465	-	LWC EF20
118	1637	4.1	LWC AF17
119	507	-	LWC Q13
<b>Fig 91</b>			
120	836	-	1.81 EF133
121	369	4	MSC F53
122	424	-	MID CL15
123	346	4.1	COC L68
124	248	-	COC F21
125	306	4.1	COC F121
126	155	4.1	LWC AF17+F31
127	1703	-	40.86 F72
128	8	5.3	LWC AF3
129	838	-	1.81 EF133
<b>Fig 92</b>			
130	519	-	LWC KF207
131	7	-	LWC AF16
132	6	-	LWC DF160
133	308	4.1	COC F121
134	451	SG 12	LWC CF65
135	1635	4.1	LWC AF17
136	271	-	COC F69
137	776	-	MID AL1
138	165	-	LWC A44
139	420	-	U/S ('Traders', St John's Street)
<b>Fig 93</b>			
140	1693	-	CM 758.36 (Victory Road, West Mersea)
141	818	-	1.81 EF7
142	433	4.2	MID CL104
143	919	4.2	1.81 DF258
144	858	-	1.81 AF27
145	152	-	LWC AF16
146	341	3.2	COC F27
147	249	3.2	COC F27
148	272	5.2	COC F74
149	943	5.2	LWC DF28
150	506	SG 10	LWC LF33
151	539	-	LWC CF7
<b>Fig 94</b>			
152	852	-	1.81 AF6
153	349	5.2	COC L139
154	1192	SG 9	LWC MF53
155	456	SG 14	1.81 EF19
156	1564	3.2	LWC NL4+L2
157	209	-	LWC BF64
158	485	SG 11	LWC BF45
159	1171	4.2	LWC JF169
160	1220	SG 10	LWC LF33
<b>Fig 96</b>			
161	882	SG 15	1.81 HF158
162	853	-	1.81 AF6
163	1168	4.2	LWC JF169
164	769	-	MID AF636
165	900	-	1.81 HF157
166	817	-	1.81 EF7

*Fig 97*

167	881	SG 15	1.81 HF158
168	401	-	X394
169	161	4.2	LWC AF29
170	160	4.2	LWC AF29
171	710	-	MID AF14
172	827	SG 14	1.81 EF19
173	918	4.2	1.81 DF258

*Fig 98*

174	343	3.2	COC L113+L30
175	965	SG 13	SPT F14
176	826	SG 14	1.81 EF19
177	823	SG 14	1.81 EF14
178	1559	-	LWC NF8
179	1186	SG 9	LWC MF53
180	583	5.2	LWC CF10

*Fig 99*

181	1629	-	CM 421.39 B43 (?Head Street)
-----	------	---	------------------------------

182	71	SG 9	LWC MF53
183	547	-	LWC CF7
184	905	-	1.81 HL95
185	1027	-	TSC 143
186	571	-	LWC CF7
187	1572	-	COC F2
188	1711	-	CM 7352.27 (Wyre Street)
189	367	-	MID AF858
190	1652	-	CM 20.97 (St John's Green)

191	596	SG 12	LWC CF65
192	878	SG 15	1.81 HF158
193	1651	-	CM 84.34 (Crouch Street)
194	157	4.2	LWC AF29
195	198	-	LWC B27 (ex SG 20?)

*Fig 102*

196	1654	-	CM 193.1965 (Long Wyre Street)
-----	------	---	--------------------------------

197	491	-	LWC C2
198	462	5.2	LWC CF57
199	1206	SG 9	LWC MF53
200	455	-	MID AF416
201	47	4.2	LWC LF100
202	413	-	MID CF144
203	880	SG 15	1.81 HF158
204	70	-	LWC MF32
205	448	-	LWC Q4
206	1216	SG 10	LWC LF33
207	460	SG 12	LWC CF65+F60

*Fig 103*

208	865	-	1.81 AF60
209	292	4.2	LWC KF64
210	1169	4.2	LWC JF169
211	768	-	MID AF577
212	1151	-	LWC LF37
213	712	-	MID AF14
214	828	SG 14	1.81 EF14/F19
215	716	-	MID AF29
216	567	-	GBS A U/S
217	307	4.1	COC F121
218	244	4.1	LWC BF46
219	837	-	1.81 EF133

*Fig 104*

220	816	-	1.81 EF7
221	172	-	LWC BF6
222	492	4.2/5.2	LWC NF27
223	815	-	1.81 EF7
224	494	4.2/5.2	LWC NF27
225	649	-	1.81 EF7
226	1170	4.2	LWC JF169
227	1155	SG 10	LWC LF33
228	598	SG 12	LWC CF65
229	1570	-	MID CF128
230	1589	-	MID AF416+F423+F544
231	1650	-	CM 5107.1925 (Culver Street)
232	1584	3.2	COC L49

*Fig 105*

233	1583	-	LWC AF26
234	73	SG 9	LWC MF53
235	1184	SG 9	LWC MF53
236	1696	-	CM (unaccessioned)
237	595	4.2	LWC CF56
238	608	SG 14	1.81 EF14/F19
239	950	-	LWC GF167
240	1653	-	CM 156.1965 (Clinic site, East Hill)
241	540	-	LWC C2
242	1700	-	CM 1904.702 (unprovenanced)

243	1561	-	1.81 MF121
-----	------	---	------------

*Fig 106*

244	1662	-	X? (31-6, East Stockwell Street)
-----	------	---	----------------------------------

*Fig 107*

245	1663	-	40.86 L20+L24+F119
-----	------	---	--------------------

*Fig 108*

246	868	-	1.81 BF96
247	1586	3/4	LWC D222
248	896	-	1.81 HF374
249	1585	-	LWC C2
250	1695	-	CM 2940.14 (Bourchier's Hall, Aldham)

251	520	-	MID EL339
252	1665	-	1.81 GF4
253	695	-	1.81 GF104
254	1660	-	CM unaccessioned (Queen Street)

*Fig 109*

255	1661	-	CM 502.1935 (Culver Street)
256	1694	-	CM 76.1971 (Barnston)

*Fig 111*

257	645	-	LWC JF12
258	1649	-	CM 780.1904 (Co-op, Long Wyre Street)

259	859	-	1.81 AF29
260	1628	-	CM 4621.23 (North Hill)
261	1690	-	5.88 AL40
262	1627	-	CM 25.1929 (Long Wyre Street)

263	901	-	1.81 HL3
264	137	5.3	LWC AF6
265	449	-	LWC CF96
266	849	-	1.81 AF3
267	364	-	MID AF722

*Fig 113*

268	466	-	LWC CF7
269	742	-	MID AF416
270	541	-	LWC C2
271	1573	-	LWC JF63
272	503	-	MID AF577
273	162	-	LWC AF31
274	942	5.2	LWC DF23
275	1578	5.3	LWC AF3
276	1577	-	LWC C44
277	638	-	LWC C176
278	582	5.2	LWC CF10
279	639	-	LWC C176
280	501	4.2	MID CL116
281	502	-	MID AL4
282	156	-	LWC AF26
283	640	-	LWC C176
284	348	3.2	COC L113
285	1193	SG 9	LWC MF53
286	1562	-	CM OS3.1973 (Great Horkelesley kiln-site)

**Mill Green ware**

**Fabric 35**

*Fig 121*

1	667	3.2	CPS L48
2	434	3.2	MID CL113
3	513	3/4.1	CPS L22+L57
4	428	3.2	MID CL87
5	1176	-	LWC BF78

**Cheam white ware**

**Fabric 23E**

*Fig 123*

1	840	-	1.81 EF209
2	136	5.3	LWC AF6
3	946	-	CSC F2
4	951	SG 9	LWC MF22

**'Tudor green' ware**

**Fabric 41**

*Fig 124*

1	29	4.2	LWC AF15
---	----	-----	----------

**Cistercian ware**

**Fabric 40C**

*Fig 125*

1	824	SG 14	1.81 EF14
2	75	-	LWC EF20
3	866	-	1.81 A47

**Unidentified English medieval wares**

**Fabric 98W**

*Fig 126*

1	1437	SG 7	COC F213
2	1438	SG 7	COC F213
3	517	3.1	MID EF972

**Fabric 98S**

4	563	SG 12	LWC CF65
---	-----	-------	----------

**Fabric 98**

5	741	-	MID AF416
6	932	-	GBS B680

**Guy's-type ware**

**Fabric 55**

*Fig 127*

1	822	SG 14	1.81 EF14/F19
2	197	SG 20	LWC BF14
3	1631	-	LWC KF124

**Post-medieval red earthenwares**

**Fabric 40**

*Fig 132*

1	233	5.2	MID AF43
2	116	5.3	LWC AF6
3	579	5.2	LWC CF19+95

4	605	-	LWC DF9
5	529	-	LWC CF7
6	1148	5.2	LWC GF26
7	317	-	COC F211
8	79	-	LWC HF30
9	738	5.2	MID AF387
10	78	-	LWC HF30

*Fig 133*

11	530	-	LWC C2
12	98	5.3	LWC AF3
13	256	5.2	COC F60
14	234	5.2	LWC CF18
15	96	5.3	LWC AF3
16	117	5.3	LWC AF6
17	531	-	LWC C2
18	796	SG 21	MID AF15
19	77	-	LWC HF30
20	1085	SG 21	MID AF15
21	44	-	LWC NF24
22	729	5.2	MID AF43
23	634	-	LWC C82
24	1149	5.2	LWC GF26

*Fig 134*

25	17	SG 20	LWC BF14
26	222	-	LWC B27
27	628	-	LWC C28
28	260	5.2	COC F60
29	1614	5.1	LWC KF15
30	258	5.2	COC F60
31	708	-	MID AF1

*Fig 135*

32	335	SG 17	COC F61
33	580	5.2	LWC CF19+95
34	95	5.3	LWC AF3
35	997	SG 22	LWC RF18
36	635	-	LWC C53
37	854	-	1.81 AF7

*Fig 136*

38	310	5.3	COC F153
39	257	5.2	COC F60
40	54	-	BKC HL2
41	1615	-	MID CF266
42	589	5.2	LWC CF42
43	377	5.2	LWC GF25
44	237	5.2	LWC C95
45	1002	SG 22	LWC RF18
46	714	-	MID AF29
47	20	-	LWC B27
48	389	5.3	LWC G20
49	115	5.3	LWC AF6
50	259	5.2	COC F60

*Fig 137*

51	227	-	LWC BF34
52	236	5.2	LWC C95
53	33	5.3	LWC AF6
54	32	5.3	LWC AF3
55	80	-	LWC HF30
56	230	-	COC 1024
57	315	5.3	COC F154
58	1117	-	X369 (42, St John's Street)
59	339	SG 17	COC F61

60	340	SG 17	COC F61
61	1143	5.2	LWC GF31
<i>Fig 138</i>			
62	187	SG 20	LWC BF14
63	739	5.2	MID AF387
64	675	3.1	CPS L22+L24
65	235	5.2	LWC CF19
66	798	SG 21	MID AF15
67	1094	SG 21	MID AF15
68	358	-	COC 1020
69	114	5.3	LWC AF6
70	288	5.1	LWC KF15
71	572	-	BKC CF11
72	269	5.2	COC F65
<i>Fig 139</i>			
73	376	SG 18	LWC GF24
74	21	SG 20	LWC BF14
75	22	SG 20	LWC BF14
76	799	SG 21	MID AF15
77	566	-	LWC U/S
78	91	5.3	LWC AF3
79	94	5.3	LWC AF3
80	602	SG 16	LWC CF77
81	588	-	LWC CF33
82	569	-	LWC CF7
83	42	5.3	LWC AF3
<i>Fig 140</i>			
84	39	SG 20	LWC BF14
85	36	5.3	LWC AF3
86	40	-	LWC B27
87	862	-	1.81 AF40
88	578	5.2	LWC CF19
89	41	-	1.81 DF154
90	58	-	BKC VF272
<i>Fig 141</i>			
91	299	-	LWC KF52+F53
92	996	SG 22	LWC RF18
93	533	-	LWC C2
94	19	-	LWC AF12
95	83	-	LWC HF30
96	241	-	MID AF711
97	37	-	LWC AF10
<i>Fig 142</i>			
98	808	-	MID D3331
99	809	-	MID D3331
100	378	5.2	LWC GF25
101	242	-	MID U/S
102	238	5.3	LWC AF3
103	158	5.3	LWC AF6
104	570	-	LWC CF7
105	92	5.3	LWC AF3
106	43	5.3	LWC AF6
107	131	5.3	LWC AF6
<i>Fig 143</i>			
108	4	-	MID AL276
109	719	-	MID AF34
110	243	-	MID AF45
111	725	-	MID AF39
112	240	-	LWC VF1
113	546	5.2	LWC CF21+F42
114	159	-	MID A1906
115	390	-	MID AF299
116	31	5.3	LWC AF3
117	26	-	LWC B27
118	722	-	MID AF36
<i>Fig 144</i>			
119	195	SG 20	LWC BF14
120	1119	SG 17	COC F61
121	629	-	LWC C28
122	118	5.3	LWC AF6
123	30	5.3	LWC AF3
124	723	-	MID AF36
125	573	5.2	LWC CF10
126	336	SG 17	COC F61
127	23	5.2	LWC BF19
128	143	-	LWC AF12
129	715	-	MID AF29
130	532	-	LWC C2
<i>Fig 145</i>			
131	193	SG 20	LWC BF14
132	427	-	1.81 DF29
133	581	5.2	LWC CF10
134	84	-	LWC HF30
135	1597	5.2	MID AF387
136	536	-	LWC C2
137	777	-	MID AL4
138	375	SG 18	LWC GF24
139	632	-	LWC C81

<i>Fig 146</i>			
140	599	SG 16	LWC CF77+F75
141	660	2.4/5.2	CPS F167
142	232	5.2	COC F65
143	630	-	LWC C80
144	345	-	COC L55
145	81	-	LWC HF30
146	287	5.1	LWC KF15
147	141	-	LWC AF12
148	400	5.3	LWC G20
149	82	-	LWC HF30
150	633	-	LWC C82
151	253	-	COC F56
152	1599	-	X369 (42, St John's Street)
153	631	-	LWC C81
154	766	-	1.81 HF628
155	552	5.2	LWC CF20
156	1598	-	LWC AF13
157	231	SG 17	COC F61
<i>Fig 147</i>			
158	1673	-	CM 20.29 (Wyre Street)
159	601	SG 16	LWC CF77
160	270	5.2	COC F65
161	97	5.3	LWC AF3
162	119	5.3	LWC AF6
163	805	-	MID U/S
164	359	-	COC 1028
165	86	-	LWC HF30
166	27	-	LWC B27
167	562	-	LWC U/S
168	544	-	LWC CF2
169	781	-	MID AF1
170	266	SG 17	COC F61
171	800	SG 21	MID AF15
172	534	-	LWC C2
<i>Fig 148</i>			
173	250	-	COC F50
174	314	5.3	COC F154
175	149	4.2	LWC AF15
176	93	5.3	LWC AF3
177	9	5.3	LWC AF3
178	797	SG 21	MID AF15
179	727	5.2	MID AF43
180	352	SG 17	COC F61
<i>Fig 149</i>			
181	998	SG 22	LWC RF18
182	1601	-	TSC F26+F27
183	535	-	LWC C2
184	564	-	MID AF1
185	170	-	LWC BF6
186	1590	SG 20	LWC BF14
<i>Fig 150</i>			
187	421	-	CM 1905.31 ('Sheepen Fort')
188	422	-	CM 1906.31 ('Sheepen Fort')
189	423	-	CM 1907.31 ('Sheepen Fort')
<i>Fig 152</i>			
190	1018	5	MID CF112 (Middleborough buried pots)
191	411	5	MID CF104 (Middleborough buried pots)
192	368	5	MID CF242 (Middleborough buried pots)
<b>Metropolitan slipware</b>			
<b>Fabric 40A</b>			
<i>Fig 153</i>			
193	558	5.2	LWC C95
194	144	-	LWC AF12
195	85	-	LWC HF30
196	34	5.3	LWC AF6
197	1147	-	X369 (42 St John's Street)
198	767	-	MID F568
199	142	-	LWC AF12
200	772	-	MID AF643
201	794	SG 21	MID AF15
202	333	-	COC F382
203	792	SG 21	MID AF15
204	140	5.3	LWC AF3
<i>Fig 154</i>			
205	57	-	BKC VF209

206	934	5.3	BKC VF185
207	935	5.3	BKC VF185
208	936	5.3	BKC VF185

**Border ware****Fabric 42***Fig 155*

1	991	SG 22	LWC RF18
2	732	-	MID AF45
3	111	5.3	LWC AF6
4	989	SG 22	LWC RF18
5	112	5.3	LWC AF6
6	268	5.2	COC F65
7	548	5.2	LWC F19+C95
8	164	-	LWC AF47
9	402	5.3	LWC G21
10	1145	-	STG L12
11	790	SG 21	MID AF15
12	35	5.3	LWC AF6
13	56	5.3	BKC VF185
14	720	-	MID AF36
15	104	5.3	LWC AF3
16	106	5.3	LWC AF3
17	113	5.3	LWC AF6

*Fig 156*

18	721	-	MID AF36
19	1162	-	X369 (42 St John's Street)
20	289	4.2	LWC KF64
21	223	-	LWC B27
22	252	5.3	LWC AF6
23	263	SG 17	COC F61
24	1070	SG 21	MID AF15
25	1024	-	TSC 67
26	1011	SG 19	LWC VF2
27	105	5.3	LWC AF3
28	525	4.2/5.2	CPS F167
29	2	-	LWC SF7
30	1647	-	CM unaccessioned
31	1071	SG 21	MID AF15
32	318	SG 17	COC F61
33	791	SG 21	MID AF15

**Netherlands, Anglo-Netherlands and English tin-glazed earthenwares****Fabric 46***Fig 159*

1	217	SG 20	LWC BF14
2	218	-	LWC B27
3	1606	5.2	LWC CF19
4	278	5.1	LWC KF15
5	280	5.1	LWC KF15
6	281	5.1	LWC KF15
7	282	5.1	LWC KF15
8	279	5.1	LWC KF15

*Fig 161*

9	551	5.2	LWC CF61+F19+95
10	283	5.1	LWC KF15
11	284	5.1	LWC KF15
12	215	-	LWC B27
13	555	5.2	LWC CF23
14	550	5.2	LWC CF19
15	557	5.2	LWC CF42
16	561	5.2	LWC CF42
17	554	5.2	LWC CF42
18	553	5.2	LWC CF42
19	549	5.2	LWC CF19
20	1030	-	LWC Pit 1
21	713	-	MID AF29
22	760	-	LWC VF1

*Fig 162*

23	90	5.3	LWC AF3
24	110	5.3	LWC AF6
25	109	5.3	LWC AF6
26	128	5.3	LWC AF6
27	123	5.3	LWC AF6
28	1022	5.3	LWC AF6

*Fig 163*

29	122	5.3	LWC AF6
30	100	5.3	LWC AF3
31	125	5.3	LWC AF6
32	750	5.2	LWC CF19
33	746	5.2	LWC C95+BF70
34	748	5.2	LWC C95+F19
35	746	5.2	LWC C95+BF70
36	749	5.2	LWC C95
37	751	5.2	LWC C95+F19
38	53	-	BKC HF6
39	731	-	MID AF45

40 762 - LWC VF1  
41 409 - MID CF99

*Fig 165*

42 213 - LWC B27  
43 69 - LWC MF26  
44 325 - LWC K6  
45 426 - MID CL26  
46 107 - LWC AF4  
47 10 - LWC F42+F19  
48 311 5.3 COC F154  
49 806 - MID A1804

*Fig 166*

50 764B SG 20 LWC BF14  
51 765B SG 20 LWC BF14

**North Devon gravel-tempered ware**

**Fabric 56**

*Fig 167*

1 1639 5.3 LWC AF6

**English stoneware**

**Fabric 45**

*Fig 168*

1 1056 SG 21 MID AF15  
2 1165 - BKC D188  
3 1164 5.3 BKC VF185  
4 810 - MID U/S  
5 38 - LWC AF4  
6 909 - 1.81 J333

**Wrotham slipware**

**Fabric 40D**

*Fig 169*

1 1602 - LWC B27

**Staffordshire-type slipware**

**Fabric 50**

*Fig 170*

1 974 - LWC VF1  
2 298 - X344  
3 730 - MID AF45

**Late slipped kitchenwares**

**Fabric 51A**

*Fig 171*

1 1707 - LWC CF7  
2 1706 - LWC VF1  
3 1709 - BUC H24

**Sussex inlaid slipware**

**Fabric 40E**

*Fig 172*

1 1667 - CSC 1

**Wheel-thrown Frankish sandy wares**

**Fabric 97F**

*Fig 174*

1 607 - LWC HF56  
2 1319 - LWC A119

**North French yellow-glazed ware**

**Fabric 95P**

3 1579 2.3 LWC GF242

**French micaceous ware**

**Fabric 95M**

4 830 - 1.81 EF117

**Rouen-type ware**

**Fabric 28**

5 208 4.1 LWC BF46

**North French monochrome ware**

**Fabric 27**

6 1675 - LWC BF18

**Saintonge ware**

**Fabric 27**

7 342 4.1 COC F121  
8 843 - 1.81 EF219  
9 538 - LWC C2  
10 388 5.3 LWC G20

**Beauvais earthenware**

**Fabric 30**

11 1670 - CM 9/3.1964 (3, Pelham's Lane)

*Fig 175*

12 403 - LWC G149

**Beauvais sgraffito**

**Fabric 30**

13 845 - 1.81 EF476  
14 842 - 1.81 EF219  
15 537 - LWC C2+176  
16 138 - LWC AF11

**Beauvais stoneware**

**Fabric 45J**

17 1604 - LWC BF2

**Martincamp flasks**

**Fabric 43**

18 855 - 1.81 AF7  
19 366 - MID AF34

**Brunssum-Schinveld ware**

**Fabric 14B**

*Fig 176*

1 293 - LWC KF217  
2 296 - LWC K109

**Andenne ware**

**Fabric 17**

*Fig 177*

1 383 2.4 LWC GF81

**Low Countries red earthenwares**

**Fabric 31**

*Fig 179*

1 1215 SG 10 LWC LF33  
2 5 SG 20 LWC BF14  
3 130 5.3 LWC AF6  
4 305 4.1 COC F121  
5 834 - 1.81 EF133  
6 857 - 1.81 AF27  
7 74 - LWC EF15  
8 145 - LWC AF12  
9 1043 SG 21 MID AF15

*Fig 180*

10 735 5.2 MID AF387  
11 916 4.2 1.81 DF258  
12 1160 - LWC J1  
13 927 - 1.81 W93  
14 1154 SG 10 LWC LF33  
15 417 - MID CF186  
16 1137 SG 17 COC F61  
17 543 5.2 LWC F2+F9  
18 14 - COC 1020  
19 1630 SG 18 LWC GF24  
20 1136 SG 17 COC F61  
21 1146 5.2 LWC D85

*Fig 181*

22 65 - BKC A3  
23 261 5.2 COC F60  
24 740 5.2 MID AF387  
25 926 - 1.81 W93  
26 600 5.1 LWC CF75  
27 737 5.2 MID AF387  
28 101 5.3 LWC AF3  
29 1161 4.2 LWC JF169  
30 874 SG 15 1.81 HF39  
31 1044 SG 21 MID AF15

*Fig 182*

32 1689 - CM 32.30 (Wyre Street)  
33 154 4.1 LWC AF17

**North Holland slipware**

**Fabric 31A**

*Fig 183*

1 1072 SG 21 MID AF15  
2 102 5.3 LWC AF3  
3 146 - LWC AF12  
4 147 - LWC AF12  
5 59 SG 18 LWC GF24  
6 132 5.3 LWC AF6  
7 803 SG 21 MID AF15  
8 133 5.3 LWC AF6  
9 773 - MID AF666  
10 1681 - LWC AF4

**Low Countries white earthenwares**

**Fabric 23C**

*Fig 184*

1 728 5.2 MID AF43  
2 906 - 1.81 H627  
3 606 5.3 LWC G73  
4 724 - MID AF36

5 1073 SG 21 MID AF15

**South Netherlands maiolica**

**Fabric 46C**

*Fig 185*

1 955 SG 13 SPT F14  
2 856 - 1.81 AF27  
3 1267 SG 15 1.81 HF158  
4 637 4.1 LWC CF81  
5 1612 - LWC BF30

**Paffrath-type ware**

**Fabric 18**

*Fig 186*

1 201 - LWC BF18  
2 1174 - LWC JF43  
3 813 - 1.81 EF4

**Siegburg stoneware**

**Fabric 45B**

*Fig 187*

1 206 SG 11 LWC BF45  
2 864 - 1.81 AF52+F30+F34  
3 839 - 1.81 EF164+F165  
4 814 - 1.81 EF7  
5 779 - MID AL5  
6 833 - 1.81 EF133  
7 576 5.2 LWC CF19

**Langerwehe stoneware**

**Fabric 45A**

*Fig 188*

1 811 - 1.81 EF2  
2 1157 4.1 LWC AF17  
3 16 SG 13 SPT F14  
4 25 4.2 LWC AF15  
5 820 SG 14 1.81 EF14  
6 616 - 1.81 HF208  
7 1212 SG 10 LWC LF33  
8 643 - LWC CF102  
9 851 - 1.81 AF6  
10 1152 - X369 (42, St John's Street)  
11 416 - MID CF186  
12 1163 - X369 (42, St John's Street)  
13 928 SG 20 LWC BF14  
14 910 - 1.81 J333

**Gothic (Saxony) stoneware**

**Fabric 45K**

*Fig 189*

1 938 4.2/5.1 LWC G110

**Raeren stoneware**

**Fabric 45C**

*Fig 191*

1 169 - LWC BF6  
2 15 - COC 1031  
3 612 - 1.81 JF113  
4 613 - 1.81 J333  
5 614 - 1.81 J333  
6 148 4.2 LWC AF15  
7 167 - LWC BF6  
8 619 - 1.81 HL3 (probably derived from SG 15)  
9 875 - 1.81 HF157  
10 617 SG 15 1.81 HF158  
11 618 - 1.81 HL3 (probably derived from SG 15)  
12 821 SG 14 1.81 EF14  
13 620 - 1.81 HL3 (probably derived from SG 15)  
14 879 SG 15 1.81 HF158  
15 593 - LWC CF55  
16 937 5.2 LWC DF90  
17 372 SG 18 LWC GF24  
18 327 - COC F382  
19 847 - 1.81 EF219  
20 1048 SG 21 MID AF15

**Cologne and Frechen stonewares**

**Fabric 45D/E**

*Fig 193*

1 611 SG 15 1.81 HF39  
2 915 4.2 1.81 DF258  
3 621 SG 19 LWC VF2  
4 609 5.2 MID AF387  
5 24 - COC F381



6	604	-	1.81 E1
7	360	-	COC 1029
8	277	5.1	LWC KF15
9	183	SG 20	LWC BF14
10	659	4.2/5.2	CPS F167
11	219	-	LWC B27
12	331	-	COC F382
13	184	SG 20	LWC BF14

*Fig 194*

14	178	SG 20	LWC BF14+SF5
15	610	-	LWC U/S
16	365	-	MID AF45
17	787	SG 21	MID AF15
18	329	-	COC F382
19	330	-	COC F382
20	255	5.2	COC F60
21	76	-	LWC HF30
22	316	-	COC F211

*Fig 195*

23	182	SG 20	LWC BF14
24	717	-	MID AF34
25	379	5.2	LWC GF26
26	542	-	LWC F2
27	334	SG 17	COC F61
28	642	-	LWC C2
29	220	-	LWC B27
30	1023	-	BUC E768
31	129	5.3	LWC AF6

**Westerwald stoneware****Fabric 45F***Fig 196*

1	139	-	LWC AF12
2	312	5.3	COC F154
3	577	5.2	LWC CF19
4	55	-	BKC VL1
5	774	-	MID AF667
6	622	SG 22	LWC RF18
7	254	-	COC F59
8	350	-	COC 1019
9	771	-	MID AF643
10	984	SG 22	LWC RF18
11	770	-	MID AF643
12	356	-	COC 1018
13	313	5.3	COC F154
14	1032	SG 21	MID AF15
15	1183	SG 20	LWC BF14

**'Hessian' crucible****Fabric 60***Fig 197*

1	1668	SG 19	LWC VF2
---	------	-------	---------

**Weser slipware****Fabric 44A***Fig 198*

1	743	-	MID AF556+F533
2	780	-	MID AF1
3	526	-	LWC CF12+2
4	788	SG 21	MID AF15
5	373	SG 18	LWC GF24

**Werra slipware****Fabric 44B**

6	527	-	LWC CF12+2
7	518	-	MID EF977
8	832	-	1.81 EF129
9	528	-	LWC C2

**Lower Rhine slipware****Fabric 44C**

10	1159	-	LWC J1
11	1166	-	BKC VF209
12	773	-	MID AF45

**Andalusian lustreware****Fabric 46B/1***Fig 199*

1	1153	SG 10	LWC LF33
2	662	3/4.1	CPS L22
3	415	-	MID CF186
4	664	3/4.1	CPS L22

**Valencian lustreware****Fabric 46B/2**

5	726	-	MID AF42
6	290	4.2	LWC KF64

**Cuerda Seca****Fabric 46D/1**

7	940	-	LWC EF24
---	-----	---	----------

**Seville maiolica****Fabric 46D/2**

8	99	5.3	LWC AF3
---	----	-----	---------

**Olive jars****Fabric 29A**

9	251	-	COC F53
10	224	-	LWC B27

**Portuguese maiolica****Fabric 46F**

11	1063	SG 21	MID AF15
----	------	-------	----------

**Iberian/North African star costrel****Fabric 62**

12	1669	-	CM 18.29 (Wyre Street)
----	------	---	------------------------

**Montelupo maiolica****Fabric 46E***Fig 200*

1	1607	5.2	MID AF43
2	371	SG 18	LWC GF24

**North Italian marbled slipware****Fabric 39**

3	807	-	MID A1804
---	-----	---	-----------

**Italian oil jars****Fabric 54***Fig 201*

1	1682	-	Church Walk (private ownership)
---	------	---	------------------------------------

*Fig 202*

2	1683	-	Church Walk (private ownership)
3	1684	-	399, Ipswich Road (private ownership)
4	1685	-	CM unaccessioned (Hollytrees Museum)
5	1686	-	CM unaccessioned (Hollytrees Museum)
6	1687	-	BKC EL25
7	1688	-	Northgate Street

**Martabani stoneware****Fabric 58***Fig 204*

1	1640	-	66.86 JL2 (Butt Road)
---	------	---	-----------------------

*Fig 205 (not used)***Mediterranean 'mercury' jars****Fabric 52***Fig 206*

1	709	-	MID AF1
2	1553	-	CM 242.1974 (West Stockwell Street)
3	1554	-	CM 3563.17 (?St Mary's hospital)
4	1555	-	CM 182.1933 (?Colchester)
5	1556	-	CM 164.1943 (West Street, Braintree)

---

## Appendix 2.

# Documentary evidence for potters and kiln-sites in the Colchester area

---

### Introduction

The main aim of this appendix is to identify local production sites or areas that supplied (or could have supplied) Colchester with pottery in the medieval and post-medieval periods. It is also concerned with details of the potters themselves, although detailed references are very seldom given in the records. Some references to the importation of pottery are given, though most references to specific types of pottery have been provided in Chapters 2-13.

### Sources

Colchester possesses a remarkably rich and varied archive of municipal records. Some of this has been published but much is not. A full search of all these sources for references to pots and potters would have taken many years and was never a realistic option. Research has therefore been concentrated on translated and printed works. Most of the research was conducted in piecemeal fashion over a number of years by the author, but I would like to acknowledge Dr R Britnell, Dr A F J Brown, John Bensusan-Butt, Geoff Tann, Chris Thornton, and Pat Ryan for providing some of the references.

Colchester's Court Rolls run from 1311 to 1600. The first 73 years were translated and published by I H Jeayes (*JCR*); the remainder was transcribed and translated by W G Benham but remains unpublished (*UCR*). The transcriptions exist as 24 hand-written volumes in the Colchester branch of the Essex Record Office. Entries up to 1425 were searched. Page references for the unpublished Court Rolls follow the pagination of Benham's transcriptions preceded by the year in question (eg *UCR* 1401, 50). Other references provided by Dr Britnell use the medieval numbering system of the original membranes (eg for the year 1435/6: *UCR* 53/1-30 where the first number is that of the roll and the others are those of the surviving membranes). Other key printed works, fully searched, are two multi-period municipal compilations known as *The Red Paper Book of Colchester (RPB)* and *The Oath Book or Red Parchment Book of Colchester (OB)*.

### Colchester and its borough

The medieval borough or 'Liberty' of Colchester included the walled town and the four large extramural parishes or hamlets of Lexden, Mile End, Greenstead, and Berechurch or West Donyland. Some of these had been attached to the

town as early as 1086 (*VCHE*, 9, 230). Berechurch lay to the south in the richest agricultural land though fringed in parts with heathland. No records of any kind of ceramic activity are known from Berechurch although there was a brickworks in the 19th century. This absence of ceramic evidence reflects the richness of the soil at Berechurch. The other three parishes occupy a broad arc of poorer soils, heath and woodland stretching from the west across to the east side of the town. The geology of this area is silty sandy clay, gravel and sand with pockets of London clay (*VCHE*, 9, 383-409). Much of this area was suitable only for rough grazing and forestry, but this sort of marginal terrain is also suitable for ceramic industries and it is no surprise that most of Colchester's evidence for pottery, brick- and tile-making is concentrated in these parishes.

References to tile- and later brick-making are always more abundant than those for pot-making. Although the following references concentrate on pot-making, it is worth mentioning the presence of related industries, even if these are later, as tile and brick production can be shown to have occurred in almost every location around Colchester where there is evidence for pottery production. Pottery and roof-tile production around Colchester seem especially linked, as they were at Danbury in central Essex (Drury & Pratt 1975), and this may be reflected at Colchester in the production of elaborate roof-furniture such as finials and louvers.

### Lexden

The parish lies to the west of Colchester.

**A** c 1300 (or early 14th century). The ledger book of St John's Abbey records that the abbot of Colchester held four and-a-half acres of land here 'in a field called Potterescroft on the northern side of the field' (Britnell 1988, 161). The field name is suggestive of potting activity at this date or earlier.

**B** c 1385 and c 1427. A tile kiln is recorded in the parish at these dates but its location according to *VCHE*, 9 is unknown (*VCHE*, 9, 398). This is possibly the same as the workshop (*fabrica*) and adjoining house near the graveyard at Lexden granted in 1377 to Richard Thursteyn of Mile End and John Popelyn of Colchester (*JCR*, 3, 144). A Richard Thursteyn is mentioned again at Mile End in circumstances suggesting he could have been a potter or tiler (*see below*), and other members (?descendants) of the same family in Colchester certainly did follow these trades.

**C** In the 19th century there were brick kilns on various sites on or near Lodge Farm (*VCHE*, 9, 398). At one of these, according to A F J Brown, 'three workers made pots as well as bricks' (Brown 1980, 9-10).

**Mile End** (alias le Milende, Mylonde)

The parish lies to the north of the town. Roadworks in the north of the parish in 1973 uncovered the site of a late 12th- to early 13th-century pottery but no kilns (Drury & Petchey 1975). The type of pottery produced was a coarse grey sandy ware (Fabric 20). The documentary references are later.

**A** Hugh Pottere (Hugo Le Pottere) of Mile End, mentioned c 1295-1330

Paradoxically, more is known about the town's first recorded potter than of his successors in this trade, who constitute little more than a string of names and dates stretching from the 14th to the 18th centuries. Over a dozen references to the activities of Hugh (and his wife) between 1295/6 and 1330 allow us a small insight into the social status of a medieval potter. The picture that emerges is undeniably shadowy and says little about the pots themselves, but the details are still worth relating in view of the rarity of such references in English medieval records. Colchester is fortunate in possessing two unusually detailed taxation lists for the years 1295/6 and 1301 (*Rotuli Parliamentorum* 1783, 1, 243ff — translations of these kindly made available by N Crummy). In the surviving lists, the name and frequently the profession of the citizen is given. It is usually apparent in the text whether the surname or the profession is being given after the forename: either the distinction is given eg 'William le Pottere, baker', or it is apparent in the nature of the citizen's goods eg 'Humphrey Tanner (*Tannator*)... leather, barks and tools in the tannery...' Hugh is first mentioned in the 1295/6 taxation under the area heading 'Vill of Mile End'.

Hugo le Potter (his taxable goods) —

For 1295/6:

- 1 cow val. 5s
- 1 2-3 yr old bullock val. 2s 6d
- Total 7s 6d
- Seventh: 13d

For the year 1301:

- Hugo le Porter (18th-century mis-spelling)
- 1 threadbare surcoat val 18d
- 1 blanket & 1 sheet val 18d
- Earthenware pots (*Ollas Luteas*) val 12d
- 1 tripod val 2½d
- 1 hook for wood val 1d
- 1 2-3 yr old bullock val 18d
- 2 lambs val 12d
- Total 6s 9½d
- Fifteenth 5½d

There can be little doubt that Hugh was a potter. Of over 400 citizens listed in the two taxations, only Hugh is specifically described as possessing earthenware pots, whereas all other pots mentioned are described as 'brass', or simply as 'pots'. Domestic earthenware pots in themselves would normally be below the limit of taxable goods and thus unworthy of mention. Consequently, the specific reference to earthenware pots given here must refer to a potter's stock-in-trade. It has been estimated that 12d-worth of pots may represent some three dozen at the most, perhaps undervalued, and that Hugh's 5½d tax would put him among the lowest 54 members of the taxable population, or the bottom 11% (Le Patourel 1968, 113). In the same taxation, 12d — the value of Hugh's pots — was equivalent in value to such

commodities as a brass pot (though these vary in value), a silver or gold ring, a silver buckle, two barrels, two bushels of wheat, two towels, two lambs or one sheep and even a small amount of verdigris or quicksilver.

The same Hugh Pottere of Mile End was still alive in 1311, from which year Colchester's earliest Court Roll survives. There are numerous references in the Court Rolls to Hugh and his wife between the years 1311-30, but they are rather uninformative and principally consist of Hugh's presence as a pledge in a number of legal conflicts between other parties. Hugh's wife (never named in person) was amerced in 1311 for brewing against the assize, along with the wives of many other citizens (*JCR*, 1, 48). In 1312 Hugh le Pottere and others supported Alexander Quintyn in his complaint against David, Abbot of St Osyth's, for seizure and detention of cattle (*JCR*, 1, 75). On 11th December 1329 Hugh le Pottere filed a complaint against Peter le Wylde for breaking some form of legal binding or covenant that they had. We never learn what this covenant was. A contract of apprenticeship springs to mind, but, as the same Peter le Wylde is listed as a man of some substance in the 1301 taxation, such a contract seems unlikely. The same complaint lists as pledges the persons of Symon Martyn and John le Pottere (*JCR*, 1, 95). John was possibly a son of Hugh or perhaps another local potter, although there were certainly at this time local people with the surname Potter who were described as working in other professions. These legal proceedings which began in December 1329 required at least half-a-dozen appearances or representations in the borough court and were finally settled in Hugh's favour on 2nd April 1330 (*JCR*, 1, 103).

**B** 1419. Lawhundred held 16th January 1419 records that John Thursteyn (*medius*) keeps a ditch not cleaned towards the land called Potteresland in Le Milende, 2 perches long. In mercy 3d' (*UCR* 1419, 72). For other references to a Richard Thursteyn 'potter', see below.

**C** By the 15th century, bricks and tiles were made from clay dug on Kingswood Heath (*VCHE*, 9, 405). Some of the clay was illegally taken by tilers from the neighbouring parish of Ardleigh (*UCR*, 1424, 44/11d). There were still brickworks at Mile End for most of the 19th century (*VCHE*, 9, 405).

**D** Three 'Kiln Fields' are recorded on the 1842 tithe map of Mile End parish. These were probably connected with brick and tile works, but there were also two fields called 'Potter Field', one in the south-west of the parish (no 128) on the Nayland Road and the other in the centre (no 204) next to fields called 'Clay Pits' and 'Tile Field'.

**Greenstead**

The parish lies to the east of the town.

**A** An estate called Throwerystye, later Rovers Tye, was first recorded here in 1353. It has been suggested that the 'thrower' after whom the estate was named may have been a potter (*VCHE*, 9, 386-7). A tilemaker was mentioned in 1370 and there was a kiln house for the manufacture of tiles at Dilbridge in 1398-9 (*ibid*). Brick- and tile-making also took place on a small scale c 1800 (*ibid*).

## The walled town and intramural parishes

Other documentary references are assumed to refer to the town of Colchester proper or to its 'intramural parishes' which in many cases extended well outside the town wall.

No documentary references have survived for the late 12th-/early 13th-century kilns at Middleborough outside the North Gate nor for the 15th-century kilns at Magdalen Street which lay beyond the South Gate.

In the late medieval period, the eastern continuation of the High Street (known as Friars Street or Frerestrete) and East Hill beyond that were something of an industrial suburb where tanners, leatherworkers and blacksmiths were concentrated (Britnell, unpublished study). Most of the evidence for medieval tile kilns at Colchester is also concentrated in the eastern suburbs of the town as far as the tile kilns at Dilbridge (Greenstead parish) which was sometimes included in the town's North Ward (*VCHE*, 9, 232). This area of Colchester was served by wells and the River Colne. Numerous references to tilers, tile kilns and clay-digging in this area occur in the late 14th- and early 15th-century Court Rolls. A tile kiln at a location here variously known as Le Dannehel or Dawmedehel is recorded from 1382 (*JCR*, 4, 97). In 1401 a certain John Pope, tiler of Friars Street, was distrained by the prior of St Botolph's for 100 tiles of 'holwerk' (hollow-work) and 200 tiles of 'playnwerk' (plain-work; *UCR* 1401, 122).

The following references to potters occur in the Court Rolls and other documents.

**A** 1357. Thomas Crouchman citizen and potter (*ollarius*) of London claimed a debt of £22 9s from several well-known townsmen. The size of the debt suggests that he could have been a founder or dealer in metal-ware vessels (*JCR*, 2, 50).

**B** 1383. Richard atte Hacche or Richard Hacch, potter. Prosecuted for debt (*JCR*, 4, 189). The name Hacche or Hecha meaning hatch or gate is mentioned several times in medieval references to the parish of Mile End. The will of a certain Richard Hach of St Nicholas' parish (High Street) was enrolled in 1423-4 (*OB*, 103).

**C** 1439-1467. Richard Thursteyn, potter. There are several references to a potter of this name in the borough records, mostly in cases of debt (*UCR*). It is uncertain whether these refer to one man or perhaps a father and son of the same name. In the list of inhabitants swearing fealty in 1451, a Richard Thursteyn, potter, and a Richard Thursteyn, tyler, are mentioned in the same list (*RPB*, 80). A Richard Thursteyn tyler is mentioned again in 1472 in a list of 'foreigners' (ie non-burgesses) dwelling in the town of Colchester who did fealty to the king (*RPB*, 82). The Thursteyns were an old Mile End family one branch of which held lands at Mile End, probably located near the chantry of Joseph Elianor, and also a messuage in East Street (see will of Roger Thursteyn; *UCR* 1418, 153). Other branches of the family appear to have moved into the pottery and tile-making industries. The name is fairly common in the town in the 15th and 16th centuries.

The references to Richard Thursteyn, potter, are as follows: 1439 (*UCR* 1439, 57/10r; debt), 1451 (*RPB*, 80; fealty), 1460 (*UCR* 1460, 71/6r; debt), 1461 (*UCR* 1461, 71/18r, debt), 1466 (*UCR* 1466, p 10; jury service) and 1467 (*UCR* 1467, 73/28r; debt).

**D** 1520/1 William Thursteyn of Colchester, potter, and his wife Anastatia made a number of deeds of lease with weavers and cordwainers in this year (*OB*, 151, nos 4, 25 and 26). A William Thursteyn, alderman, and Anastatia his wife, are referred to in 1541-2 (*OB*, 161), and a William Thursteyn, tilemaker, and Joan, his wife, are mentioned in 1533-4 (*OB*, 156).

**E** 1571. Jasper Andries, pott maker, borne in Brabant (Britton 1986, 21 & 22). This celebrated delftware potter, who is credited with the introduction of tin-glazed pottery to England, was briefly a resident of Colchester where he attended the Dutch Church. His brother Lucas was also here in 1573. Jasper Andries is believed to have earlier set up a kiln at Norwich and he eventually did set up a kiln in London, probably at Aldgate. There is no evidence that Andries ever established a kiln at Colchester.

**F** c 1683. Abraham Vol was apprenticed to the London delftware potter Thomas Harper in this year at the Montague Close pot works in Southwark. Abraham's son Humerston was also apprenticed to his father at Southwark in 1695. This potter's family were members of the Dutch Church at Colchester in whose registers they appear 1666-1709. Durrel Vole, potseller, son of Abraham Vole of St Botolph's, Colchester was buried in 1704 (Edwards 1974, 116). It is not known if any members of this family ever made pots at Colchester.

**G** 1715. Jonathan Bonnard, potter, of St Nicholas' parish. Mentioned in Colchester Petty Sessions (A F J Brown, pers comm).

**H** c 1750. A pottery is said to have been set up in Colchester about this time but no further details are known. A brick kiln was also in operation at the Hythe in 1756 (Brown 1968, 157).

**I** 1754. Joshua Willmott. This trader placed an advertisement in the *Ipswich Journal* (1st June 1754) which suggests that he may have been a potter, among other things, or at least was involved in selling refractory clay. The advertisement runs, 'To be sold, at the sign of the Sun in All Saints' parish in Colchester. A flying chariot for the diversion of children... and two marble boards almost new. Likewise fine clay stoves made to boil tea-kettles or heat heaters, from 1 to 3 at a time; and at the same time you may boil a large joint of meat, all with a small expense of firing. They will also draw to admiration. Also wool comb-pots made, only giving a week's notice, of any size from 1 to 6. By the maker Joshua Willmott. N.B. Any person may have any of the clay which is as good as any in England. Any of these to be sold very cheap'.

From the above it would seem that the clay stoves were fairly large if they could boil kettles and large joints of meat at the same time. The wool comb-pots would have been used by woolcombers for heating their iron woolcombs. In the 19th century, comb-pots were usually short drum-shaped stoves made of iron (Geraint Jenkins 1972, fig 7.3), but the advertisement of Joshua Willmott could suggest that earlier comb-pots were sometimes made of clay.

**J** 1762. Hassells and Keeling pot makers. These were Staffordshire potters who ran a warehouse for Staffordshire wares in Wyre Street, Colchester and later near the Red Lion Inn in the High Street (*Ipswich Journal*, 18th June 1763 (see also p 251 for full discussion).

**K** 1799. James Bordman, potter of St Nicholas' parish mentioned in Colchester Sessions (A F J Brown, pers comm).

## Customs and ordinances affecting pottery

**A** 1377-99. Customs payable to the Water Bailiff in the time of Richard II. This runs as follows. 'A remembraunce of the custume of diverse chafays (wares) comynge out of dyverse cuntres, using by old tyme with owytn ony mind [time without mind] at the Burgh & Havene of Colchest'. There follows a list which includes the following:

'Potts de Ryne, c., jd' ie probably Rhenish stoneware pots; 1d per hundred (*OB*, 6-7).

'Pottys of erthe, a carful, jd'. May refer to importation of Dutch earthenware pots (*ibid*, 10).

'Flandres tyl, j mill jd'. Earliest local reference to importation of Flemish tiles; taxed at 1d per thousand (*ibid*, 9).

**B** A separate statute of the time of Richard II as follows, 'And if a man comes to town with a pack at his back, or a bay with mercery, and goes or stands in the town to show his ware, for each day, ½d' then follows a list of relevant professions including 'Potmakers' under the group headed 'Forwarders' (*OB*, dors fol 8).

## Pottery and tile manufacture in adjacent parishes

Some of the most specific documentary and other information relates to adjacent parishes which undoubtedly supplied Colchester with pottery, bricks and tiles in the medieval and later period. These lay outside the borough, although this fact was sometimes disputed. Much of the land in these parishes was owned by Colchester burgesses.

### Great Horkesley

The parish lies to the north of Mile End and shares its geology of sand, gravel and London Clay.

**A** c 1279-80 & 1293-4. In researching the history of Great Horkesley for the *Victoria County History of Essex (VCHE, 10*, in prep), Chris Thornton has come across some 13th-century references to potters in the parish and has kindly allowed these to be summarised here. In the Middle Ages, Great Horkesley was part of the manor of Nayland in Suffolk and it is from the account rolls of Nayland (in the Public Record Office) that these references are derived. The southern part of Great Horkesley lay within the royal forest of Cestrewald which was cleared during the 13th century and the area later to be known as Horkesley Heath. As at Mile End, forest clearance encouraged potters to move into the area. Ten geese worth 2s 1d were received from potters' rents in 1279-80, and in 1293-4 another 12d rent was paid by 'twelve newly arrived' potters for digging clay in Cestrewald. With at least a dozen potters in the area by the late 13th century, the pottery industry at Great Horkesley was already quite a large-scale concern. Where the potters were 'newly arrived' from is, of course, a question of considerable interest. They may have moved up from Mile End, but this is no more than speculation.

**B** Two 14th-century pottery-making sites, lying around

3.5 miles north-west of Colchester, were investigated in 1973 at the same time as the pottery site at Mile End was investigated (Drury & Petchey 1975, 54-9). It is now recognised that the Great Horkesley potteries were producing Colchester-type ware (Fabric 21A) as well as sandy greyware (Fabric 20; see Chapter 4). There are two specific late medieval references to potters at Great Horkesley.

**C** 1405. 'John Popelote, potter of Horkeslegh, a burgess of Colchester' (*UCR*, 1405, 50). He and his sons John and Thomas Popelote (of Bergholt) were fined for various petty crimes. John Snr was fined for taxing two other burgesses of Mile End. His sons were fined for the forestalling (illegal buying for retail) of corn and other goods. John Popelote Snr may be the same person of that name, together with his wife Matilda and son Nicholas, mentioned in the Colchester Taxation of 1377 (membrane 2, column a), and he may also be the same John Popelote who was admitted as a burgess of Colchester in 1389-90 (*OB*, 79). Assuming a transcription error, the John Popelyn of Colchester who set up a 'workshop' in Lexden in 1377 (with Richard Thursteyn of Mile End; see above, Lexden) could be the same as John Popelote of Horkesley. In connection with this it may be significant that a Richard Thursteyn and a John Popelote were engaged in a litigation for debt in 1419 (*UCR* 1419, 145).

**D** 1466. In the household accounts of John Howard, Constable of Colchester Castle and later first Duke of Norfolk, the following record of payment is found for the year 1465-6: 'And the V yere of the XXVII day of Janever, Wateken bocher of Stoke delyverd of my mony to on of the poteres of Horkesley 1111s. Vld to pay heme selfe and is felawes for XI dosen potes' (Hudson Turner 1841, 326).

Wateken or Watkin may have been butcher to the Howard family at their family seat at Stoke-by-Nayland, three miles further north in Suffolk. The 132 pots thus ordered by Howard work out at less than a halfpenny each (0.409d each).

**E** 1755. 'Christopher Downs of Great Horkesley, potmaker.' Marriage licence no 348 in Colchester Local Studies Library.

### Ardleigh

The parish lies to the east of Colchester beyond the parishes of Greenstead and Mile End and continues their geology of sands, gravel and London Clay. Ardleigh village lies about four miles north-east of Colchester.

**A** c 1206. Crocklesford from Crockerford, meaning the 'potters' ford' is first mentioned in the Feet of Fines for Essex in this year (Reaney 1935, 326). There is no other evidence for pottery production in the parish as early as this, although a Roman pottery kiln has been found in the parish. Crockleford Heath is perhaps the most likely area where pottery production would have been located.

**B** c 1424-39. Tilers were active in the parish at this time. Alan Squyer and others in 1424 were fined for digging clay at Kingswood Heath, in Mile End parish, and taking it away to Ardleigh to make tiles (*UCR* 1424, 44/11d). An Adam Squyer was fined for a similar offence in 1439 (*UCR* 1439, 57/10r).

**C** c 1575-1750. 'Pottkilns'. This production site produced post-medieval red earthenware (Fabric 40) at least within the dates indicated, although the founding date of the tenement is unknown. It is likely that the site was a major supplier of pottery to Colchester in the post-medieval period. The site of Ardleigh kiln was tracked down using documentary sources by a local archaeologist/historian, the late Felix Erith, in 1963-4 and was reported by him (Erith 1964). Mr Erith kindly showed me the site of the kiln in 1986, and a small surface collection of glazed wasters was made on this and later occasions. The following summary is based almost entirely on Mr Erith's report. It is hoped that a fuller account together with pottery illustrations will be produced at a future date.

The parish registers of Ardleigh record the following potters' names.

**D** 1583. William Ley, a potter. Died.

**E** 1587. Richard Ley, the potter. Died.

**F** A second Richard Ley, potter of Ardleigh, is named in 1616 (Brears 1971, 180) and was presumably the same person whose will was proved at Chelmsford in 1619 (Emmison 1957-8, I, 256).

**G** The kiln-site presumed to be that of these potters now lies partly submerged at the western extremity of Ardleigh Reservoir (TM 022289) beside the Old Ipswich Road only three miles from Colchester. Large amounts of pottery were found here by the owners in the 1940s but unfortunately these samples cannot be traced. The earliest reference to the tenement known as Pottkilns occurs in 1648 when a certain Dunstan Rochester, son of Samuel Rochester, was tenant. It is uncertain who did the actual pot-making, the owners or occupiers of the tenement. Their names are given below.

Date	Owner	Occupier
1637	?Samuel Rochester (d)	-
1648	Dunstan Rochester	Thomas Turner
1738	Jonathan Sadler	William Sadler and Edward Edwards
1796	?	William Sadler and Edward Edwards

William Sadler and Edward Edwards were still alive in 1796 when a survey lists their trade as that of husbandmen. On this basis Felix Erith assumed that pottery had ceased on the site a decade or so previously.

The wasters recovered by myself appear to be of 17th- to 18th-century date and include wide bowls, storage jars, tripod pipkins, dripping pans and small handled bowls. Glazed peg-tile kiln-furniture was also recovered.

**H** Brick- and tile-making continued in the parish in the late 18th and 19th centuries (Erith 1964, 13).

### East Donyland

This area lies to the south-east of the town adjacent to the borough boundary. A medieval pottery kiln is said to have existed in the grounds of Roman Hill House, a MOD property at TM 009210 (Doorne 1980, 9 and pers comm). The 'kiln' is said to have been found during the construction of tennis courts there by a relative of the late Mrs K de Brisay. Beyond this there is no evidence. I visited the site in 1987 with no result.

### Wivenhoe

The parish lies about three miles south-east of Colchester on the Colne estuary. The earls of Oxford, who made their family residence here, built a tile works and forge here in the late 15th century (Britnell 1986, 253). A 'Potters Field' is marked on the 1846 tithe map (no 69; TM 043239).

### Outlying areas

The following areas, all within a dozen miles of Colchester, are likely to have supplied pottery to the town in the medieval or post-medieval periods. It is hoped that a fuller account of fieldwork and documentary work at these locations will be published at a future date.

### Dedham

This village lies on the Essex-Suffolk border, 6.5 miles north-east of Colchester.

**A** The earliest suggestion of potting here is contained in the will of Edward Dorant of Dedham proved at Chelmsford in 1569. In this Dorant left his flockbed to a certain Thomas Ponde 'provided that he shall faithfully help my wife for a time to potter the ware and do the business that is needful...' (Emmison 1983, 2, 200, will no 700).

**B** Next there is the evidence of the 1841 tithe map which contains a cluster of field names derived from the pottery and brick-making industries and centred on TM 059321 near Dedham Heath. Within this area are two adjacent fields called 'Pot Kiln Field' (nos 783 and 784) and a field (?and buildings) called 'Mount Carmel Pottery' (no 788). Wasters of post-medieval red earthenware (Fabric 40), peg-tile kiln-furniture and brick wasters have been collected from these sites. These appear to be of late 18th-/early 19th-century date.

### Thorpe-le-Soken

The village lies in the Tendring peninsula, eleven miles east of Colchester. The evidence for a potter here in the 18th century is taken from two advertisements in the *Ipswich Journal* kindly made available by John Bensusan-Butt. Except where indicated, these transcriptions are not verbatim.

**A** *Ips. J.* 29th October 1750

Thomas Glide potmaker, at the White Lion, Thorpe. Makes earthenware pipes to lay underground at 1s 6d a yard, they will carry a large current of water at least 40 years. Apprentice wanted.

**B** *Ips. J.* 8th October 1757

Notice of bankruptcy. Thomas Glide potter, Thorpe-le-Soken. Afflicted with gout. A large assortment of extream good earthenware, well-leaded and the best of the kind that has been exposed for sale for many years past... All country gardeners that want any Auricula pots or Job-pots...

may have any quantity of extremely good flower pots on the shortest notice. Also earthen pipes for underground drains and welms for gateways... Fire crack'd ware, well mended with white lead and oil half price... A journeyman may depend on good encouragement and constant work either by the week or hundred.

Glide's earthenware was almost certainly post-medieval red earthenware (Fabric 40). 'Welms' or 'Whelms' was a dialect word for the covering of a channel under a gateway. Colchester was renowned for its auriculas from the late 17th century onwards (Morant 1748, 1, 88) and doubtless many of Glide's flowerpots were destined for the town.

### Tiptree

Tiptree lies nine miles south-west of Colchester on the Maldon Road. The modern town is formed from parts of the 19th-century parishes of Inworth, Messing, Great Wigborough and Tolleshunt Knights which converge on Tiptree Heath.

**A** A 'Potter Row' here is shown on Chapman and André's map of 1777. This is now a small group of buildings partly fronting the Maldon Road (B1022) and which includes the Ship Inn (TM 887154). Potters Row is probably to be

identified with a reference to a Potters rowe near Inworth mentioned in 1344 (Reaney 1935, 37). In 1420, tiles were brought from a Potter rowe by means of a boat from Goldhanger Mill and taken to repair buildings at Foulness (*ERO D/DHt M45*). Potters and tilers were among the tradesmen banned from collecting firewood on Tiptree Heath by an ordinance of Henry VIII (Morant 1768, 2, 142).

**B** Several field names in the vicinity of Potters Row are also strongly suggestive of pottery including the Pot Kiln Field and Potters Row Field shown on 19th-century tithe maps. Fieldwalking here by the author in 1987-8 yielded extremely little from the most suggestive fields but the large field directly behind the Ship Inn and Potters Row itself proved to be rich in evidence for pottery and tile making.

In contrast to the sterility of surrounding fields, that behind Potters Row produced hundreds of sherds of medieval and post-medieval pottery. Definite wasters of 17th- and 18th-century post-medieval red earthenware (Fabric 40) were recovered together with peg-tile kiln-furniture. A large amount of medieval greyware (Fabric 20) was also recovered, mostly cooking pots of the period *c* 1250-1400, together with some jugs and part of a chimney pot. A smaller amount of 13th- to 14th-century Colchester-type ware (Fabric 21A) was also recovered. Of the medieval wares, only the greyware (Fabric 20) included one or two definite wasters.

---

## Appendix 3.

# Neutron activation analysis of redware pottery from north-east Essex, including Colchester-type wares

by M J Hughes

---

### Summary

Redware ceramics from the Great Horkesley and Magdalen Street kilns can be distinguished from each other and other Essex redwares by neutron activation analysis (NAA). Some apparently early Colchester-type wares show chemical similarities to ceramics from the Great Horkesley kilns.

### Introduction

As part of a neutron activation analysis project on medieval and late medieval redware pottery in south-east England being undertaken by the British Museum, Department of Scientific Research, a number of specific questions focus on ceramics of the area in north-east Essex around Colchester, including the relationship between Colchester-type redware and those produced elsewhere in Essex. The initial results of the redware analysis project have been published (Gaimster *et al* 1992; Nenck & Hughes 1992a & 1992b) and indicate that this analytical technique can differentiate between the products of the known kilns in this region of England. The analyses of the products of the kilns around Colchester had not been included in the previous publications and are now reported here.

The main focus of the analytical programme on Colchester-type wares was on pottery of the 15th century, though some earlier pottery of this type is known and a few examples have been analysed. The fabric of this type of ware is a sandy orange, almost certainly made from the local London Clay which mostly outcrops to the north of the town. Colchester-type ware is part of a wider medieval tradition of Essex redwares, many of which are similar in the appearance of their fabric, and therefore difficult to identify when found on sites at some distance from their production centre, including distribution within Essex itself and in London.

Colchester-type wares are known from excavations in and around the town itself, and two definite kiln-sites have been located in the area. One, at Great Horkesley (The Rookery kiln-site: Drury & Petchey, 1975) lies about 3.5 miles north-west of the town, and during excavations produced typical pottery of Colchester-type including cisterns with bung-holes. The area has a long history of pottery production from the 12th century onwards, and documentary evidence suggests that it may have been an industry of some size. The other kiln-site was found in Colchester itself, just outside the town wall at Magdalen Street (Cunningham 1982a); the quantity of pottery wasters found here were

more numerous than those at the Great Horkesley kiln, and included jug-shaped cisterns.

The aim of the present investigation was to try to answer the following questions:

1. Could pottery from the Great Horkesley and Magdalen Street kilns be distinguished by NAA? (They cannot be distinguished by thin-section petrology.)
2. Can Colchester-type wares be distinguished from other red sandy Essex wares, eg Harlow pottery?
3. A few sherds of apparently much earlier pottery in a related fabric exist: what relationship do they have to Colchester-type?
4. Do some rare contemporary sherds in polychrome or sgraffito decoration also relate to this industry?

### Selection of samples and reference analyses of pottery

The present rather modest project aimed to try to answer these questions using relatively small numbers of samples, as a full-scale study was not possible. Six samples of typical Colchester-type pottery were selected from each of the two kiln-sites at Great Horkesley and Magdalen Street. Two sherds of the apparently early Colchester-type pottery were analysed, together with one example each of the polychrome and the sgraffito-decorated pottery. The list of samples analysed is given in Table 1.

For comparison with the analyses on these pieces, and to aid in answering question (2) above, 50 previously analysed samples of Essex redwares were available in a database. These comprised a relatively large number of redwares and blackwares from Harlow (representing three kiln-sites in the town) and smaller numbers of sherds from Ingatestone (the Mill Green production centre), Stock, Rayleigh, and South Woodham Ferrers (these latter four sites are in the region of Essex between Chelmsford and Southend, some 20-30 miles south of Colchester).

Another relevant set of NAA results against which the Colchester-type results were compared was a selection of sixteen 15th-century polygonal chimney bricks from several Essex sites which have been analysed as part of a separate analytical project (Wickenden, forthcoming).



Table 1 List of samples of Colchester-type ceramics analysed by neutron activation.

OBS	BMRL	Cat no	Description	Site
1	50652W	1994.4-2.7	body sherd	Colchester, Magdalen Street
2	50651Y	1994.4-2.4	body sherd with slip	Colchester, Magdalen Street
3	50650P	1994.4-2.3	body sherd with glaze streaks	Colchester, Magdalen Street
4	50649X	1994.4-2.2	body sherd with slip traces	Colchester, Magdalen Street
5	50648Z	1994.4-2.1	body sherd of cistern	Colchester, Magdalen Street
6	50653U	1994.4-2.8	body sherd with slip traces	Colchester, Magdalen Street
7	50659T	10	jug handle, white slip; middle	Great Horkesley
8	50658V	8	jug handle, white slip; early	Great Horkesley
9	50657X	7	sherd, white slip, middle	Great Horkesley
10	50656Z	3	jug handle, white slip; middle	Great Horkesley
11	50655Q	2	jug rim, white slip; middle	Great Horkesley
12	50654S	4	sherd, white slip; middle	Great Horkesley
13	50644W	21	body sherd	Colchester, Lion Walk ditch
14	50645U	COC 78 (445)	polychrome Mill Green copy	Colchester, Long Wyre Street
15	50646S	LWC 71, D235	body sherd	Colchester, Lion Walk
16	50647Q	1989.6-6.32	sherd with sgraffito	Colchester, Lion Walk

Table 2 Results.

OBS	BMRL	Na	K	Rb	Cs	Ca	Sc	Fe	Cr	Co	La	Ce	Eu	Sm	Lu	Yb	Hf	Th	Ta	Tb	U	Ba	As	Sb	Zn	
1	50652W	0.28	2.02	120.49	7.36	7.83	19.72	5.26	125.45	52.67	37.98	83.31	1.71	7.08	0.45	2.92	6.74	11.40	1.86	0.96	1.73	24.05	15.68	0.87	94.43	
2	50651Y	0.30	2.43	129.52	8.21	-	21.43	7.10	145.05	91.61	42.33	92.17	2.22	9.54	0.58	3.74	6.24	11.58	2.16	1.16	2.66	521.75	37.75	1.16	102.70	
3	50650P	0.29	2.32	129.83	7.81	-	21.98	5.90	140.39	23.66	44.16	95.93	2.10	9.37	0.50	3.33	6.11	11.43	0.92	1.20	2.24	648.66	22.67	2.08	96.05	
4	50649X	0.31	2.42	135.31	8.49	-	22.24	5.95	140.50	25.32	43.69	91.83	2.21	9.14	0.50	3.17	5.72	11.73	1.27	1.15	2.13	591.56	24.91	8.86	120.32	
5	50648Z	0.32	2.33	125.01	8.09	-	20.83	6.10	142.06	67.42	39.98	85.02	2.01	8.89	0.51	3.34	6.15	11.76	1.78	1.13	2.33	516.67	25.89	0.92	110.96	
6	50653U	0.29	2.32	133.97	8.47	-	21.01	5.16	144.43	78.75	40.36	85.16	1.97	8.40	0.47	3.27	6.75	11.36	2.10	1.11	2.31	392.18	16.44	1.21	115.54	
7	50659T	0.19	1.63	93.91	6.72	-	15.32	4.24	104.62	22.94	23.32	46.61	0.82	3.95	0.30	1.74	5.62	9.49	1.02	0.49	1.65	286.84	12.98	0.89	66.34	
8	50658V	0.27	2.40	122.14	7.19	-	19.36	5.80	140.74	40.92	41.44	92.46	2.11	9.30	0.51	3.39	5.71	11.40	1.41	1.18	2.37	331.64	19.94	1.15	116.59	
9	50657X	0.23	1.76	100.18	7.12	-	18.52	5.32	129.06	19.56	33.34	72.13	1.42	6.09	0.41	2.50	6.25	11.41	1.02	0.81	1.90	176.22	19.56	1.11	116.91	
10	50656Z	0.23	1.64	95.86	6.05	-	16.20	4.96	113.83	8.98	30.18	62.11	1.16	5.80	0.39	2.18	6.12	11.62	0.96	0.66	2.04	473.03	20.03	1.20	72.76	
11	50655Q	0.25	1.90	105.37	7.03	-	17.88	4.73	119.81	11.67	28.39	58.73	1.09	5.02	0.37	1.97	6.28	10.24	1.04	0.56	1.99	314.54	12.61	1.44	90.76	
12	50654S	0.26	2.19	121.74	7.77	-	19.75	5.41	142.43	52.88	34.62	73.42	1.57	7.00	0.39	2.58	5.81	10.62	1.51	0.96	2.63	354.40	15.04	1.88	112.19	
13	50644W	0.23	2.40	128.27	8.22	-	17.09	5.21	135.02	20.84	37.99	80.92	1.77	7.40	0.42	2.82	5.44	10.59	0.99	0.99	1.93	342.37	13.67	0.83	97.98	
14	50645U	0.30	2.04	109.99	7.12	-	16.53	5.18	122.03	16.61	41.85	70.57	1.91	8.82	0.50	3.15	5.83	10.74	0.90	1.06	1.95	333.13	12.80	0.97	87.08	
15	50646S	0.18	2.18	138.21	8.57	-	17.75	4.76	136.77	101.90	33.05	76.94	1.70	6.21	0.36	2.62	5.31	11.38	2.22	0.93	2.26	384.62	11.35	0.78	103.33	
16	50647Q	0.30	2.28	121.42	8.73	-	22.07	5.16	150.37	80.25	32.04	61.57	1.14	5.46	0.36	2.31	6.52	12.09	2.04	0.70	1.97	367.66	14.45	2.27	101.55	
<b>Magdalen Street</b>																										
m.		0.30	2.30	129	8.07	-	21.2	5.91	139	56	41.4	82.9	2.02	8.74	0.50	3.29	6.3	11.5	1.68	1.12	2.22	499	23.9	2.5	106	
s.d.		0.01	0.15	5	0.43	-	0.9	0.7	7	27	2.3	5.0	0.19	0.90	0.04	0.26	0.4	0.2	0.49	0.08	0.31	121	8.0	3.3	10	
<b>Great Horkesley</b>																										
m.		0.24	1.92	106	6.97	-	17.8	5.08	125	26	31.8	67.5	1.36	6.19	0.40	2.39	5.9	10.8	1.15	0.77	2.09	322	16.6	1.27	95	
s.d.		0.02	0.31	12	0.56	-	1.7	0.5	15	17	6.1	15.0	0.45	1.83	0.07	0.57	0.3	0.8	0.23	0.20	0.35	96	3.3	0.32	22	

m. and s.d.: mean and standard deviation for the products of the respective kilns (6 samples of each analysed)

## Neutron activation analysis and multivariate statistics

Samples were obtained from each of the sherds in Table 1 using a 2-mm tungsten carbide drill fitted in a small low-voltage drill. The powders were analysed using the neutron activation analysis method described by Hughes *et al* 1991. The results are given in Table 2. We routinely analyse for 23 elements in each sample, and 12 of these elements were used in the statistical assessment: these comprised the well-measured elements, covering a broad cross-section of the Periodic Table and omitting elements which may volatilise during pottery firing such as arsenic and antimony. Calcium was below detection limit (approx 0.5%) in practically all the samples and so was not used in the statistics; the clays used are therefore all non-calcareous, which accords with the use of London Clay for their production.

The analytical results were combined with the earlier database of Essex redwares, and statistical examination was carried out using the SAS (SAS 1990) programs for multivariate statistics. Cluster analysis is a statistical procedure for placing into groups any ceramics whose compositions are close to each other. It works not on any archaeological criteria but on the analyses alone. Ceramics which have the same chemical composition are presumed to originate from the same particular source clay. Cluster analysis was first carried out using two different methods, namely K-means (using FASTCLUS) and Ward's method (using CLUSTER), both being followed by discriminant analysis on the resulting clusters of samples to obtain information on which elements were responsible for the differences between the sample clusters, and to display the relationships between the clusters. Both cluster analysis methods showed that only a few groups with different compositions were present among the samples, and that there was substantial agreement between the results of the two methods (which use different criteria for assigning samples to clusters). The optimum number of clusters was indicated by statistical information generated during the SAS cluster analyses, including the cubic clustering criterion and both T and F statistics. Significant changes in these test statistics occurred between five and six clusters, indicating six clusters to be the optimum number. The testing of hypotheses such as that posed in question (1) can be done by discriminant analysis alone if the number of samples is large, hence it cannot be applied in isolation here. Discriminant analysis differs from cluster analysis in that it is a statistical method for testing whether any two or more pre-defined groups of ceramics are different in composition, and to indicate wherein the differences lie. The pre-defined groups may include ceramics from two kiln-sites, or (as here) groups first defined by cluster analysis — in which case it is primarily a means of visually displaying the chemical relationship between groups. Cluster analysis can deal with much smaller numbers of samples, though at the cost of losing some of the statistical rigour. The results of the statistical tests can be considered under the four questions raised.

An initial test of all Colchester-type wares against the whole of the Essex database showed a clear separation from the ceramics from Harlow, South Woodham Ferrers, Mill Green and Rayleigh, but with associations forming between the bricks and the Colchester-type wares. The lack of compositional overlap with the ceramics from the rest of Essex

meant that it was appropriate to re-run the statistical tests on the north Essex samples only, with a few contrasting pieces from south Essex.

The results of the analyses have been shown in the plot of the first two discriminant scores in Figure 248, where the numbers refer to the clusters of samples of similar compositions. The membership of the cluster groups numbered 1-6 are as follows:

- Cluster 1: 6 polygonal bricks + 1 Great Horkelesley kiln sample
- Cluster 2: 6 polygonal bricks + 2 Great Horkelesley
- Cluster 3: 5 Magdalen Street + 1 Great Horkelesley
- Cluster 4: 3 South Woodham Ferrers + 1 Rayleigh kiln sample
- Cluster 5: 2 Great Horkelesley + 2 bricks + 2 Colchester early pieces
- Cluster 6: 3 polygonal bricks + 1 Colchester early piece

## Discussion

### 1. Great Horkelesley and Magdalen Street kilns

Five of the Magdalen Street kiln samples fall into one composition group (cluster 3) together with one Great Horkelesley piece. The other five Great Horkelesley kiln samples fall into other composition clusters. There is therefore a high degree of separation in composition between the products of these two kilns. Since the first discriminant score (CAN1) is positively correlated with all twelve elements used in the statistics, Figure 248 (and Table 2) shows that cluster 3 is characterised by higher concentrations of most elements compared to the clusters containing the majority of the Great Horkelesley samples (clusters 1, 2 and 5).

### 2. Colchester-type and other Essex ceramics

The non-overlap in composition between the Colchester samples and those from further south in Essex, as noted above, indicates that the compositions determined by NAA are different, and that Colchester-type wares can be distinguished chemically from samples from the other kiln-sites tested.

### 3. Colchester test pieces

Two purportedly early Colchester-type wares from Lion Walk, Colchester were analysed: no 15 (Table 1) and no 13 fell into composition cluster 5, which contained two Great Horkelesley kiln samples and two 15th-century bricks. This would indicate that these early pieces are local products, linking them tentatively to the Great Horkelesley area.

### 4. Polychrome and sgraffito ceramics

The sgraffito ceramic (no 16: Table 1) did not fit in compositional terms into the six clusters but, as Figure 248 indicates, it is close in composition to cluster 5 which

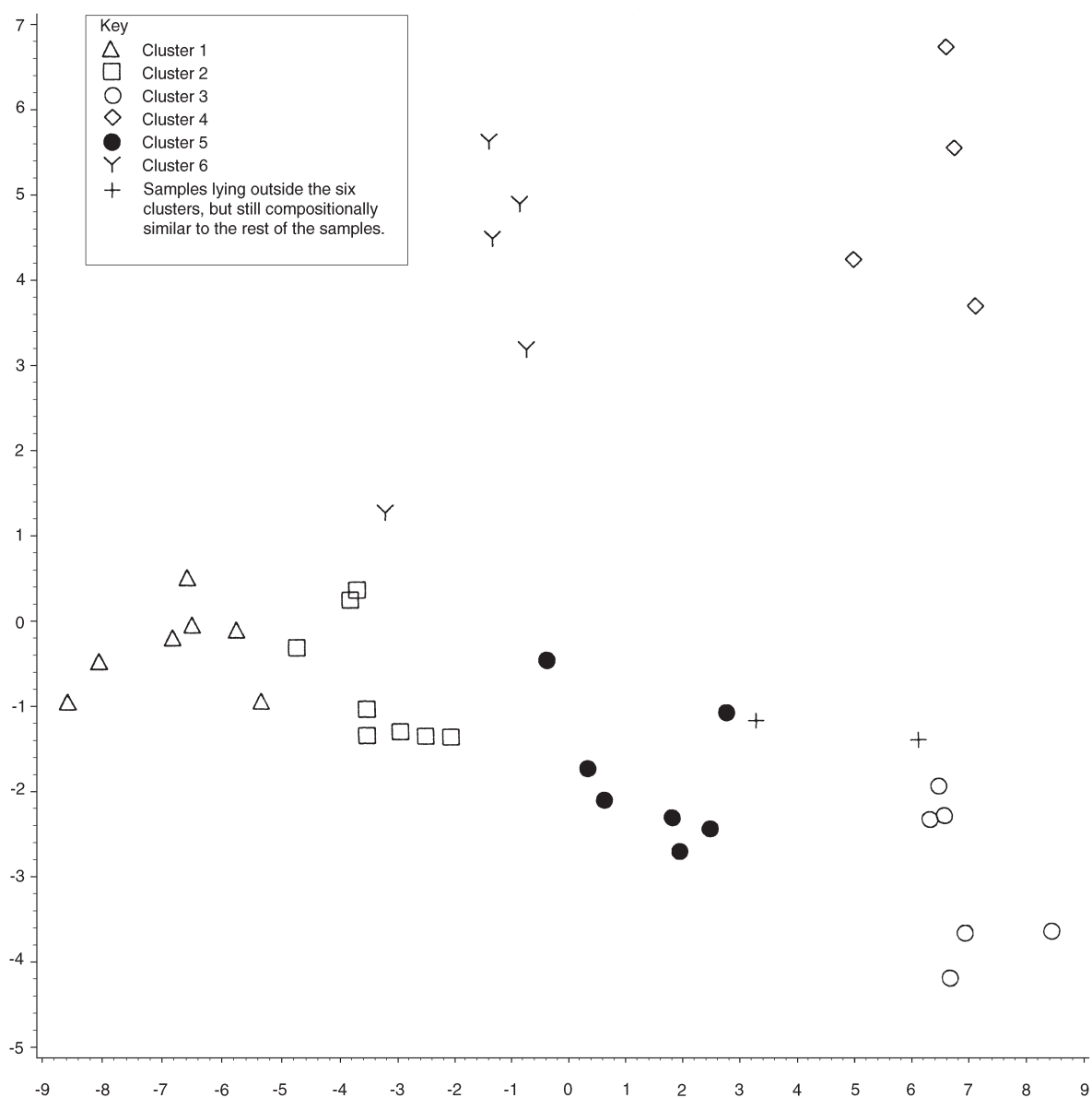

Fig 248 Plot of the first two discriminant analysis scores (CAN1 and CAN2) for six clusters of samples derived from neutron activation analysis — cluster 1: triangles; 2: squares; 3: empty circles; 4: diamonds; 5: filled circles; 6: Y; and the two crosses are samples lying outside the six clusters, but still compositionally similar to the rest of the samples.

contained the two early pieces and is therefore also linked to Great Horkesley. The polychrome Mill Green copy, no 14 from Colchester, fell into cluster 6 with three brick samples although the position of no 14 on the discriminant plot (Figure 248) indicates that it is fairly close in composition to the brick samples of clusters 1 and 2. Its production appears therefore to be related to these bricks and to some of the Great Horkesley kiln samples present in these two clusters. An origin in this area of north-east Essex seems probable from the analysis.

## Conclusions

There is a good degree of chemical separation between the composition of the two Colchester-type pottery kilns at Great Horkesley and Magdalen Street, as determined by neutron activation analysis. The products of these kilns are also different in composition to sandy wares produced at a similar period further south in Essex. Some apparently early Colchester-type wares show chemical similarities to the ceramics from the Great Horkesley kilns, as does a polychrome Mill Green copy.

---

## Bibliography

---

### Abbreviations

BAR	British Archaeological Report
BM	British Museum
CAG	Colchester Archaeological Group
CAR	Colchester Archaeological Report
CAR 1	Philip Crummy, <i>Aspects of Anglo-Saxon and Norman Colchester</i> , CBA Research Report, <b>39</b>
CAR 3	Philip Crummy, <i>Excavations at Lion Walk, Balkeene Lane, and Middleborough, Colchester, Essex</i>
CAR 4	Nina Crummy (ed), <i>The coins from excavations in Colchester 1971-9</i>
CAR 5	Nina Crummy (ed), <i>The post-Roman small finds from excavations in Colchester, 1971-85</i>
CAR 6	Philip Crummy, <i>Excavations at Culver Street, the Gilbert School, and other sites in Colchester, 1971-85</i>
CAR 9	Nina Crummy, Philip Crummy & Carl Crossan, <i>Excavations of Roman and later cemeteries, churches and monastic sites in Colchester, 1971-88</i>
CAR 10	Robin P Symonds & Sue Wade, <i>Roman pottery from excavations in Colchester, 1971-86</i>
CAR 12	Rosemary Luff, <i>Animal bones from excavations in Colchester, 1971-85</i>
CBA	Council for British Archaeology
CM	Colchester Museum
CMC	Carol Cunningham
CMR	<i>Reports of the Colchester Museum</i>
EAA	<i>East Anglian Archaeology</i>
EAH	<i>Essex Archaeology and History</i>
ERO	Essex Record Office
HBMC	Historic Buildings and Monuments Commission
JCR	Jeayes, I H (ed), 1921-41, <i>Court Rolls of the Borough of Colchester, Colchester</i> (4 vols, years 1311-83)
JC/JPC	John P Cotter
LAMAS	London and Middlesex Archaeological Society
MoLAS	Museum of London Archaeology Service
OB	Benham, W G (ed), 1907, <i>The Oath Book or Red Parchment Book of Colchester</i>
PRO	Public Records Office
Rot Parl	Record Commissioners 1783, <i>Rotuli Parliamentorum</i> (6 vols)
RPB	Benham, W G (ed), 1902, <i>The Red Paper Book of Colchester</i>
SG	Stratified Group
TEAS	Transactions of Essex Archaeological Society
TLMAS	Transactions of London and Middlesex Archaeological Society
UCR	Benham, W G, unpublished, translation and transcript of the Court Rolls of the Borough of Colchester 1384-1600 (24 vols, ERO (Colchester))
VCHE 9	J Cooper (ed), 1994, <i>A History of the County of Essex</i> , <b>9</b> , <i>The Borough of Colchester</i>
XRF	X-ray fluorescence

### References

- Addyman, P V, 1965 'Late Saxon settlements in the St Neots area: I: the Saxon settlement and Norman castle at Eaton Socon, Bedfordshire', *Proc Camb Antiq Soc*, **58**, 38-73
- Addyman, P V, & Biddle, M, 1965 'Medieval Cambridge: recent finds and excavations', *Proc Camb Antiq Soc*, **58**, 74-137
- Addyman, P V, & Hill, D H, 1969 'Saxon Southampton: a review of the evidence, part 2', *Proc Hants Field Club*, **26**, 61-96
- Allan, J P, 1983 'Some post-medieval documentary evidence for the trade in ceramics', in Davey & Hodges 1983, 37-45
- \_\_\_\_\_, 1984 *Medieval and post-medieval finds from Exeter, 1971-1980*
- Ashdown, J, 1968 'Seventeenth-century pottery from Wrotham, Kent', *Kent Archaeol Review*, **14**, 13-17
- \_\_\_\_\_, 1972 'Oil jars', in 'Mewstone Ledge site: summary of work and results, 1969-70', by R Middlewood, *Int J Nautical Archaeol*, **1**, 147-53
- \_\_\_\_\_, 1974 'The oil jar as a London shop sign', *The London Archaeologist*, **2**, 166-70
- \_\_\_\_\_, 1975 'The oil jar as a shop sign, an addendum', *The London Archaeologist*, **2**, 239-40
- Askey, D, 1981 *Stoneware bottles*
- Atasoy, N, & Raby J, 1989 *Iznik*
- Baker, D, 1974 'Excavations in the area of Mill Street, Bedford, 1971', *Bedfordshire Archaeol J*, **9**, 99-128
- Baker, D, Baker, E, Hassall, J, & Simco, A, 1979 'Excavations in Bedford 1967-77', *Beds Archaeol J*, **13**, 1-309
- Barford, P M, 1986 'The excavations and fieldwork of R H Farrands, 1950-1985', *CAG Bulletin*, **29**, 3-15
- Barker, D, 1993 *Slipware*, Shire Album no 297
- Barnard, E A B, 1948 'Sparrows and sparrow-pots', *Trans Worcestershire Archaeol Soc*, **25**, 50-56
- Barton, K J, 1964 'The excavation of the medieval bastion at St Nicholas's Almshouse, King Street, Bristol', *Medieval Archaeol*, **8**, 184-212
- \_\_\_\_\_, 1965 'Medieval pottery at Rouen', *Archaeol J*, **122**, 73-85
- \_\_\_\_\_, 1979 *Medieval Sussex pottery*
- \_\_\_\_\_, 1986 'Pottery report', in 'Excavations at Oyster Street, Portsmouth, Hampshire, 1968-71', by R Fox & K J Barton, *Post-med Archaeol*, **20**, 79-184
- Baxter, M, 1994 *Exploratory multivariate statistics in archaeology*
- Benfield, S, & Garrod, S, 1992 'Two recently-discovered Roman buildings in Colchester', in *EAH*, **23** (3rd series), 25-38
- Bennett, P, Frere, S S, & Stow, S, 1982 *Excavations at Canterbury Castle, The archaeology of Canterbury*, **1**
- Bird, B, 1987 *Rebel before his time: a study of John Ball and the English Peasants' Revolt of 1381*
- Blaxill, E A, 1938 *A history of Lion Walk Congregational Church, Colchester, 1642-1937*

- Blinkhorn, P, 1989 'Middle Saxon pottery from the Buttermarket kiln, Ipswich, Suffolk', *Medieval Ceramics*, **13**, 12-16
- Blinkhorn, P, forthcoming The Ipswich ware project: ceramics trade and society in middle Saxon England, Medieval Pottery Research Group Special Paper
- Borremans, R, & Warginaire, R, 1966 *La Céramique D'Andenne. Recherches de 1956-1965*
- Brears, P C D, 1971 *The English country pottery: its history and techniques*
- Britnell, R H, 1986 *Growth and decline in Colchester, 1300-1525*
- \_\_\_\_\_, 1988 'The fields and pastures of Colchester, 1280-1350', *EAH*, **19** (3rd series), 159-65
- Britton, F, 1986 *London delftware*
- Brooks, C, & Hodges, R, 1983 'Imported pottery in eastern Britain c 1200-1500 — an interim appraisal of the evidence', in Davey & Hodges 1983, 231-43
- Brown, A F J, 1968 *Colchester in the eighteenth century*
- \_\_\_\_\_, 1980 *Colchester 1815-1914*
- Bruijn, A, 1979 *Pottersvuren langs de Vecht. Aardwerk rond 1400 uit Utrecht*, Rotterdam Papers, **3**
- Buckley, D, & Eddy, M, 1979 'South Woodham Ferrers, Lambert's Farm', in 'Work of the Essex County Council Archaeology Section, 1978', by C R Couchman (ed), *EAH*, **11** (3rd series), 67-70
- Burns, B, 1991 'Post-medieval Normandy stonewares from Guernsey', in *Custom and ceramics: essays presented to Kenneth Barton*, by E Lewis (ed), 104-127
- Bushnell, G H S, & Hurst, J G, 1953 'Some further examples of sgraffito ware from Cambridge', *Proc Camb Antiq Soc*, **46**, 21-6
- Celoria, F S C, & Kelly, J H, 1973 *A post-medieval pottery site with a kiln base found off Albion Square, Hanley, Stoke-on-Trent, Staffordshire*, City of Stoke-on-Trent Mus Archaeol Soc Rep, **4**
- Chaffers, W, 1965 *Marks and monograms on European and oriental pottery and porcelain* (1863)
- Chapelot J, Galinié, H, & Pilet-Lemière, J (eds), 1987 *La céramique (V<sup>e</sup>-XIX<sup>e</sup>): fabrication, commercialisation, utilisation, Actes du Premier Congrès International d'Archéologie Médiévale*, 87-99
- Chapman Waller, W, 1898 'Essex field names. Part 3: Hundreds of Rochford, Dengie and Thurstable', *TEAS*, **6**, ns, 258-77
- Charleston, R J (ed), 1976 *World ceramics*
- Christie, P M, & Coad, J G, 1980 'Excavations at Denny Abbey', *Archaeol J*, **137**, 138-279
- Christophers, V R, Haselgrove, D C, & Pearcey, O H J, 1977 *The Fulham pottery*, Fulham and Hammersmith Hist Soc Occas Paper, **1**
- Christy, M, 1907 'The manufacture of pottery', *Victoria County Histories: Essex*, **2**, 413-14
- Clark, F R, Johnson, C C, & Clare, P E F, 1972 'A 17th-century metropolitan ware kiln at Loughton', *Essex J*, **7** (no 1), 6-14
- Clarke, H, & Carter, A, 1977 *Excavations in King's Lynn 1963-1970*, Medieval Archaeol Monograph Series, **7**
- Clarke, D T-D, 1975 *The Siege of Colchester 1648*
- Cockerill, C, & Woodward, D, 1975 *The Hythe: port, church and fishery*, Colchester Public Library (ref E. COL 387.1)
- Coleman-Smith, R, 1979 'British coarse wares', in *Castle Street: the pottery*, by C Gaskell Brown (ed), Plymouth Mus Archaeol Series, **1**, 13-25
- Coppack, G, 1980 'Medieval and post-medieval pottery', in Christie & Coad 1980, 223-52
- Corder-Birch, A, 1985 'A brief history of brickworks in the Heddingham area', *Essex J*, **20** (no 3), 66-7
- Cotter, J P, 1992 "'The mystery of the Hessian wares", post-medieval triangular crucibles', in Gaimster & Redknap 1992, 256-72
- Couchman, C, & Eddy, M, 1979 'Elmdon, Duddenhoe End', in 'Work of the Essex County Council Archaeology Section, 1978', by C R Couchman (ed), *EAH*, **11** (3rd series), 55-7
- Cra'ster, M D, 1966 'Waterbeach Abbey', *Proc Camb Antiq Soc*, **59**, 75-95
- Crummy, P, 1999 'In search of the siegeworks of 1648', *The Colchester Archaeologist*, **12**, 16-17
- Cunningham, C M, 1982a 'Medieval and post-medieval pottery', in Drury 1982, 358-80
- \_\_\_\_\_, 1982b 'The medieval pottery', in *Saffron Walden: excavations and research 1972-80*, by S R Bassett, CBA Res Rep, **45**, Chelmsford Archaeol Trust Rep, **2**, 80-85
- \_\_\_\_\_, 1984 'Colchester ware louvers', *CAR*, **3**, appendix 4, 211-15
- \_\_\_\_\_, 1985 'A typology for post-Roman pottery in Essex', 'The pottery', and 'The Stock pottery', in *Post-medieval sites and their pottery: Moulsham Street, Chelmsford*, by C M Cunningham & P J Drury, Chelmsford Archaeol Trust Rep, **5**, CBA Res Rep, **54**, 1-16, 63-77, 83-8 respectively
- \_\_\_\_\_, 1988 'The medieval pottery', in *The Prehistoric and Roman settlement at Kelvedon, Essex*, by K A Rodwell, Chelmsford Archaeol Trust Rep, **6**, CBA Res Rep, **63**, 129-31
- \_\_\_\_\_, forthcoming Excavations at Maldon, Essex
- Cunningham, C M, Farmer, P G, & Farmer, N C, 1983 'A horse and rider *aquamanile* from Harwich, and the significance of Scarborough ware in Essex', *EAH*, **15** (3rd series), 54-67
- Dallas, C, 1994 'Pottery', in *Excavations at Fishergate, Norwich, 1985*, by B Ayers, *EAA*, **68**, 19-29
- Davey, P, & Hodges, R (eds), 1983 *Ceramics and trade: the production and distribution of later medieval pottery in north-west Europe*
- Davis, J R, 1981 *Colchester, 1600-1662: politics, religion and officeholding in an English provincial town*, *Dissertation Abstracts International*, **42** (no 2)
- Dawson, G J, 1979 'Excavations at Guy's Hospital 1967', *Res vol Surrey Archaeol Soc*, **7**, 27-65
- Dickinson, P G M, & Cherry, J, 1965 'The treasure trove from Hartford, Huntingdon', *Proc Camb Antiq Soc*, **58**, 138-40
- Doorne, A A, 1980 'The Highfield site', in *CAG Bulletin*, **23**, 8-11
- Draper, J, 1984 *Post-medieval pottery 1650-1800*
- Drey, R E A, 1978 *Apothecary jars*
- Drewett, P L, 1975 'Excavations at Hadleigh Castle, Essex, 1971-72', *J Brit Archaeol Assoc*, 3rd series, **38**, 90-154
- Drury, P J, 1976a 'A group of mid 13th-century pottery from Naylinghurst, Braintree', *EAH*, **8** (3rd series), 267-71
- \_\_\_\_\_, 1976b 'Braintree: excavations and research, 1971-76', *EAH*, **8** (3rd series), 1-143
- \_\_\_\_\_, 1982 'Aspects of the origins and development of Colchester Castle', *Archaeol J*, **139**, 302-419
- Drury, P J, Cunningham, C M, Kilmurry, K, & Walker, J S F, 1993 'The later Saxon, medieval and post-medieval pottery', by P J Drury with contributions by C M Cunningham, K Kilmurry & J S F Walker, in *Rivenhall: investigations of the villa, church and village 1950-77*, by K A Rodwell & W J Rodwell, CBA Res Rep, **80**, Chelmsford Archaeol Trust Rep, **4.2**, 78-95
- Drury, P J & Petchey, M R, 1975 'Medieval potteries at Mile

- End and Great Horkesley, near Colchester', *EAH*, **7** (3rd series), 33-60
- Drury, P J, & Pratt, G D, 1975 'A late 13th- and early 14th-century tile factory at Danbury, Essex', *Medieval Archaeol*, **19**, 92-164
- Drury, P J, & Wickenden, N P, 1982 'An early Saxon settlement within the Romano-British small town at Heybridge, Essex', *Medieval Archaeol*, **26**, 1-40
- Dumortier, C & Veeckman, J, 1994 'Un four de majoliques en activité à Anvers vers 1560', *Bulletin des Musées Royaux d'Art et d'Histoire*, Parc du Cinquantenaire Bruxelles, **65**, 163-217
- Dunmore, S, Gray, V, Loader, T, & Wade, K, 1975 *The origin and development of Ipswich: an interim report*, *EAA*, **1**, 57-67
- Dunnett, B R K, 1966 'Excavations on North Hill, Colchester', *Archaeol J*, **123**, 27-61
- Dunning, G C, 1950 'Notes on the Trinity College jug', *Proc Camb Antiq Soc*, **44**, 49-50
- \_\_\_\_\_, 1959 'Pottery of the Late Anglo-Saxon period in England', in Dunning *et al* 1959, 31-78
- \_\_\_\_\_, 1961a 'Saxo-Norman pottery', in 'Excavations in Lewis's Gardens, Colchester, 1955 and 1958', by K M Richardson, *TEAS*, series 3, **1**, 31
- \_\_\_\_\_, 1961b 'Medieval chimney-pots', in *Studies in building history*, by E M Jope, 78-93
- \_\_\_\_\_, 1962 'Saxon and Norman pottery from Colchester Castle Park', *Antiq J*, **42**, 62-7
- \_\_\_\_\_, 1964 'Barrel-shaped and cylindrical costrels on the Continent and in England', in *Winchester excavations 1949-1960*, **1**, by B Cunliffe, 127-40
- \_\_\_\_\_, 1966a 'A pottery louver from Great Easton, Essex', *Medieval Archaeol*, **10**, 74-80
- \_\_\_\_\_, 1966b 'Medieval pottery roof ventilator from Weybread, Suffolk', *Proc Suffolk Inst Archaeol*, **30**, 284-5
- \_\_\_\_\_, 1967 'Late medieval jugs with lettering', *Medieval Archaeol*, **11**, 233-41
- \_\_\_\_\_, 1974 'The horse and knight roof-finial, with a discussion of knight finials and rider finials in England and on the Continent', in Baker 1974, 112-22
- \_\_\_\_\_, 1975 'Roof fittings', in Platt & Coleman-Smith 1975, 186-97
- \_\_\_\_\_, 1976 'Aardenburg ware from Manningtree, Essex, and finds of Aardenburg ware and other pottery imported from the Low Countries found in England and Wales', *EAH*, **8** (3rd series), 184-99
- Dunning, G C, Hurst, J G, Myres, J N L, & Tischler, F, 1959 'Anglo-Saxon pottery: a symposium', in *Medieval Archaeol*, **3**, 1-78
- Eddy, M R, 1980a 'Great Sampford, Monks Cottage', in 'Work of the Essex County Council Archaeology Section, 1979', by M R Eddy, *EAH*, **12** (3rd series), 70-71
- \_\_\_\_\_, 1980b 'Thaxted, Weaverhead Street', in 'Work of the Essex County Council Archaeology Section, 1979', by M R Eddy, *EAH*, **12** (3rd series), 75
- Edwards, R, 1974 'London potters circa 1570-1710', *J Ceramic Hist*, **6**
- Emmison, F G (ed), 1957-8 *Wills of Chelmsford*, **1**
- \_\_\_\_\_, (ed), 1969 *Wills of Chelmsford*, **3**
- \_\_\_\_\_, 1983 *Wills of the county of Essex (England)*, **2**
- Erith, F H, 1964 'Tracking down a pottery kiln from documentary sources', *CAG Bulletin*, **7**, 12-15
- \_\_\_\_\_, 1966 'The coarse pottery from St Mary's rectory garden', *CAG Bulletin*, **9**, 47-51
- \_\_\_\_\_, 1972 'The well at Bramford', *CAG Bulletin*, **15**, 1-12
- Evison, V I, 1979 A corpus of wheel-thrown pottery in Anglo-Saxon graves, The Royal Archaeological Institute Monograph Series
- Evison, V I, Hodges, H, & Hurst, J G (eds), 1974 *Medieval pottery from excavations: studies presented to Gerald Clough Dunning*
- Farley, M, & Leach, H, 1988 'Medieval pottery production areas near Rush Green, Denham, Buckinghamshire', *Records of Bucks*, **30**, 53-102
- Farmer, P G, 1979 *An introduction to Scarborough ware and a re-assessment of knight jugs*
- Farmer, P G, Farmer, N C, Pearson, T, Watkins, G, Murray, C, Herteig, A, Williams, D F, & Tomber, R, 1982 'Symposium on Scarborough ware', *Medieval Ceramics*, **6**, 66-119
- Gaimster, D R M, 1987 'The supply of Rhenish stoneware to London, 1350-1600', *The London Archaeologist*, **5** (no 13), 339-47
- \_\_\_\_\_, 1988a 'Post-medieval ceramic stove-tiles bearing the royal arms: evidence for their manufacture and use in southern Britain', *Archaeol J*, **145**, 314-43
- \_\_\_\_\_, 1988b 'Lower Rhine slipware found in Britain', in *Keramik vom Niederrhein*, by J Naumann, 167-78
- \_\_\_\_\_, 1993 'A survey of the production, distribution and use of ceramics in the Lower Rhineland c 1400-1800: some methodological studies', in *Assembled articles 1: symposium on medieval and post-medieval ceramics, Nijmegen 2 and 3 September 1993*, by H Clevis & J Thijssen (eds), 177-94
- \_\_\_\_\_, 1997 *German stoneware: 1200-1900*
- Gaimster, D R M, & Redknapp, M (eds), 1992 *Everyday and exotic pottery from Europe c 650-1900: studies in honour of John G Hurst*
- Gaimster, D R M, & Verhaeghe, F, with a contribution by Hughes, M J, 1992 'Handles with face-masks: a cross-Channel type of late medieval highly decorated basin', in Gaimster & Redknapp 1992, 304-323
- Garner, F H, & Archer, M, 1972 *English delftware*
- Geraint Jenkins, J (ed), 1972 *The wool textile industry in Great Britain*
- Girling, F A, 1964 *English merchant's marks*
- Godden, G A, 1980 *An illustrated encyclopaedia of British pottery and porcelain*
- \_\_\_\_\_, 1983 *The handbook of British pottery and porcelain marks*
- \_\_\_\_\_, 1985 *Guide to British pottery and porcelain*
- Groeneweg, G, 1992 *Bergen op Zooms aardewerk, Bijdragen tot de Studie van het Brabantse heem deel*, **35**
- Hamerow, H, 1993 *Excavations at Mucking, 2: the Anglo-Saxon settlement*, English Heritage Archaeol Rep, **21**
- Hartley, D, 1939 *Made in England* (1987 edition)
- Haslam, J, 1975 'The excavation of a 17th-century pottery site at Cove, East Hampshire', *Post-med Archaeol*, **9**, 164-87
- \_\_\_\_\_, 1984 *Medieval pottery in Britain*, Shire Archaeology, **6**
- Hawkes, C F C, & Hull, M R, 1947 'Camulodunum', Rep Res Comm Soc Antiq London, **14**
- Heal, A, 1957 *The signboards of old London shops*
- Hills, A, 1944 'The Gestingthorpe pot works', *Essex Review*, **53**, 37-44
- Hinton, D A, 1973 *Medieval pottery of the Oxford region*
- Hinton, M, & Nelson, S, 1980 'Medieval and later pottery made in Kingston upon Thames', reprinted from *The London Archaeologist*, **3** (no 14), 377-83
- Hobson, R L, 1903 Catalogue of English pottery in the British Museum
- Hodges, R A, 1981 *The Hamwih pottery: the local and*

- imported wares from 30 years' excavations at Middle Saxon Southampton and their European context, *CBA Res Rep*, **37**
- Hodgkin, J E, & Hodgkin, E, 1891 *Early English pottery: named, dated and inscribed* (1973)
- Holling, F W, 1969 'Seventeenth-century pottery from Ash, Surrey', *Post-med Archaeol*, **3**, 18-30
- Holmes, M R, 1951 'The so-called "Bellarmine" mask on imported Rhenish stoneware', *Antiq J*, **31**, 173-9
- Honey, W B, 1954 *The ceramic art of China*
- \_\_\_\_\_, 1964 *English pottery and porcelain*
- Horne, J, 1996 *A collection of early English pottery, part 16*, auction catalogue; Jonathan Horne Antiques Ltd, Kensington, London
- Hudig, F W, 1929 *Delfter Fayence*
- Hudson Turner, T, 1841 'Accounts and memoranda of Sir John Howard, first Duke of Norfolk, AD 1462 to AD 1471', in *Manners and household expenses of England*, part 3, lxxv-xciii & 149-621
- Huggins, R M, 1972 'Appendix 1: pottery', in 'Monastic grange and outer close excavations, Waltham Abbey, Essex, 1970-1972', by P J Huggins, *EAH*, **4** (3rd series), 97-110
- \_\_\_\_\_, 1976 'Pottery', in 'The excavation of an 11th-century Viking hall and 14th-century rooms at Waltham Abbey, Essex, 1969-71', by P J Huggins, *Medieval Archaeol*, **20**, 101-114
- \_\_\_\_\_, 1978 'The medieval pottery', in 'Exploratory excavation within the monastic precinct, Waltham Abbey, 1972', by A E S Musty, *EAH*, **10** (3rd series), 127-73
- \_\_\_\_\_, 1986 'Medieval and post-medieval pottery', in 'Excavations in Braintree 1980 and 1984', by B H Milton, *EAH*, **17** (3rd series), 87-90
- \_\_\_\_\_, 1988 'Appendix 1: pottery', in 'Excavations on the north side of Sun Street, Waltham Abbey, Essex 1974-75: Saxon burials, precinct wall and south-east transept', by P J Huggins, *EAH*, **19** (3rd series), 136-40
- Hughes, M J, forthcoming *Neutron activation analysis of Italian and Spanish tin-glazed pottery*
- Hughes, M J, Cowell, M R & Hook, D R, 1991 'Neutron activation analysis procedure at the British Museum', in *Neutron activation and plasma emission spectrometric analysis in archaeology*, by M J Hughes, M R Cowell, & D R Hook (eds), *BM Occas Paper*, **82**, 29-46
- Hull, M R, 1958 *Roman Colchester*
- \_\_\_\_\_, 1960 'St Nicholas' Church site, Colchester', *TEAS*, **25** (2nd series), 301-328
- Hunter, R, 1979 'Appendix: St Neots-type ware', in Williams 1979, 230-40
- Hurman, B, 1988 'The pottery', in 'Excavation of an early post-medieval kiln at Temple Street, Brill, 1983', by P A Yeoman, *Records of Bucks*, **30**, 135-44
- Hurst, J G, 1955 'Saxo-Norman pottery in East Anglia, part I, general discussion and St Neots ware', *Proc Camb Antiq Soc*, **49**, 43-70
- \_\_\_\_\_, 1959 'Middle-Saxon pottery', in Dunning *et al* 1959, 13-31
- \_\_\_\_\_, 1961a 'The pottery', in 'Medieval and later pottery from Stockwell Street, Colchester', by B P Blake, J G Hurst, & L H Gant, *TEAS*, **1** (3rd series), 41-51
- \_\_\_\_\_, 1961b 'The kitchen area of Northolt Manor, Middlesex', *Medieval Archaeol*, **5**, 211-99
- \_\_\_\_\_, 1966 'Waterbeach: the medieval pottery', in Cra'ster 1966, 89-93
- \_\_\_\_\_, 1970-71 'Sixteenth-century Beauvais drinking-jugs', *Bulletin Groupe de Recherches et d'Etudes de la Céramique du Beauvais*, **3**, 6-15
- \_\_\_\_\_, 1974 'Sixteenth- and seventeenth-century imported pottery from the Saintonge', in Evison *et al* 1974, 221-62
- \_\_\_\_\_, 1976 'The pottery', in *The archaeology of Anglo-Saxon England*, by D M Wilson (ed), 283-348
- \_\_\_\_\_, 1977 'Spanish pottery imported into medieval Britain', *Medieval Archaeol*, **21**, 68-105
- \_\_\_\_\_, 1981 'Nieder Selters mineral-water containers', in 'Some late 17th- to late 18th-century finds from Kilkenny Castle', by P D Sweetman, *Proc Royal Irish Acad*, **81**, C (no 10), 262-6
- Hurst, J G, Neal, D S, & van Beuningen, H J E, 1986 *Pottery produced and traded in north-west Europe 1350-1650*, Rotterdam Papers, **6**
- Hurst, J G, & West, S E, 1957 'Saxo-Norman pottery in East Anglia, part 2, Thetford ware with an account of Middle Saxon Ipswich ware', *Proc Camb Antiq Soc*, **50**, 29-60
- Janssen, H L, 1983 'Later medieval pottery production in the Netherlands', in Davey & Hodges 1983, 121-85
- Jennings, S, 1981 *Eighteen centuries of pottery from Norwich*, *EAA*, **13**
- \_\_\_\_\_, 1983 'The pottery', in *Thetford-type ware production in Norwich*, by M Atkin, B Ayers, & S Jennings, *EAA*, **17**, 74-97
- Johnston, A G, Foster, P J, & Bellamy, B, 1997 'The excavation of two late medieval kilns with associated buildings at Glaphorn, near Oundle, Northamptonshire', *Medieval Ceramics*, **21**, 13-42
- Jones, A, 1988 *The coarse earthenwares*, Ironbridge Archaeol Series, **14**
- Kelly, J H, & Greaves, S J, 1974 *The excavation of a kiln base in Old Hall Street, Hanley, Stoke-on-Trent, Staffordshire*, City of Stoke-on-Trent Mus Archaeol Soc Rep, **6**
- Kiddell, A J B, 1954 'Wrotham slipware and the Wrotham brickyard', *Trans of the English Ceramic Circle*, **3**, part 2, 105-137
- Kilmurry, K, 1980 *The pottery industry of Stamford, Lincolnshire c 850-1250*, *BAR*, **84**
- King, Mr, 1779 'Roman antiquities discovered in Essex, communicated by Mr King in a letter to the Secretary. Read March 20, 1777', *Archaeologia*, **5**, 229-31
- Klinge, E, 1979 *Deutsches Steinzeug: der Renaissance- und Barockzeit*, Hetjens-Museum: Deutsches Keramikmuseum
- Larwood, J & Camden Hotton, J, 1868 *The history of signboards*
- Le Patourel, H E, 1968 'Documentary evidence and the medieval pottery industry', *Medieval Archaeol*, **12**, 101-126
- Lewis, J M, & Evans, D H, 1982 'Southern European imported pottery in Wales', *Medieval and Later Pottery in Wales*, **5**, 76-81
- Macpherson-Grant, N, 1978 'Medieval pottery', in 'Excavations at 16-21 North Lane, Canterbury', by P Bennett, *Archaeol Cantiana*, **94**, 178-90
- \_\_\_\_\_, 1981 *Local wares at Canterbury: 1. Saxo-Norman and medieval shell-on-surface sandy ware. An initial form and decoration type series*, Canterbury Archaeol Trust
- \_\_\_\_\_, 1982 'The Saxo-Norman features', in Bennett *et al* 1982, 165-8
- \_\_\_\_\_, 1986 'Interim note on a 12th-century pottery kiln from Canterbury', *Medieval Ceramics*, **10**, 49-55
- \_\_\_\_\_, 1990 'Pottery from post-Roman levels', in *Excavations in the Cathedral precincts, 2, Linacre Garden, 'Meister Omers' and St Gabriel's Chapel*, by J C Driver, J Rady, & M Sparks, *The archaeology of Canterbury*, **4**, 176-9
- \_\_\_\_\_, forthcoming 'The pottery', in *Excavations in the cathedral precincts I: Lanfranc's Dormitory, the Aula Nova and the*

- Almonry Chapel, by P Bennet, S Campbell, S S Frere, J Rady, & S Stow, *The archaeology of Canterbury*, **3**
- Mainmann, A J, 1990 *Anglo-Scandinavian pottery from 16-22 Coppergate, The archaeology of York*, **16/5**
- Mann, J de L, 1971 *The cloth industry in the west of England from 1640 to 1880*
- Martin, E A, 1975 *The excavation of a moat at Exning, EAA*, **1**, 24-38
- Mayes, P, & Butler, L A S, 1983 *Sandal Castle excavations 1964-1973*
- McCarthy, M, 1979 'The pottery', in Williams 1979, 151-229
- McCarthy, M, & Brooks, C M, 1988 *Medieval pottery in Britain AD 900-1600*
- Meddens, F M, & Redknap, M, 1992 'A group of kiln waste from Harding's Farm, Mill Green, Essex', *Medieval Ceramics*, **16**, 11-43
- Mellor, M, 1976 'The pottery', in *Excavations on Fuller's Hill, Great Yarmouth*, by A E Rogerson, *EAA*, **2**, 169-96
- Merrifield, R, 1987 *The archaeology of ritual and magic*
- Milefanti, H C, & Brears, P C D, 1971 'Pottery kilns at Rawmarsh, near Rotherham, Yorkshire', *Post-med Archaeol*, **5**, 193-5
- Minchington, W E (ed), 1963 *Politics and the port of Bristol in the eighteenth century*, Bristol Records Soc Publ, **23**
- Moorhouse, S, 1972 'Medieval distilling apparatus of glass and pottery', *Medieval Archaeol*, **16**, 79-122
- \_\_\_\_\_, 1983a 'A semi-circular firecover from the Tyler Hill kilns, Canterbury', *Medieval Ceramics*, **7**, 101-7
- \_\_\_\_\_, 1983b 'The medieval pottery', in Mayes & Butler 1983, 83-212
- \_\_\_\_\_, 1986 'Non-dating uses of medieval pottery', *Medieval Ceramics*, **10**, 85-123
- Morant, P, 1748 *The history and antiquities of the most ancient town and borough of Colchester*
- \_\_\_\_\_, 1768 *The history and antiquities of the county of Essex* (1816 edition)
- Musty, J, 1974 'Medieval pottery kilns', in Evison *et al* 1974, 41-65
- \_\_\_\_\_, 1977 'Pots for the hothouses at Hampton Court and Hanworth', *Post-med Archaeol*, **11**, 102-3
- Mynard, D C, 1984 'A medieval pottery industry at Olney Hyde', *Records of Bucks*, **26**, 56-85
- Mynard, D C, Petchey, M R, & Tilson, P G, 1983 'A medieval pottery at Church End, Flitwick, Bedfordshire', *Bedfordshire Archaeol J*, **16**, 75-84
- Mytum, H, 1978 'A pottery bird whistle from Warwick', *Post-med Archaeol*, **12**, 129
- Nenk, B, in prep 'The medieval pottery', in 'Excavations at Southchurch Hall, Southend', by D R M Gaimster, *EAH*
- Nenk, B, & Hughes, M J, 1992a 'A medieval sgraffito-decorated jug from Mill Green', *EAH*, **23** (3rd series), 51-6
- \_\_\_\_\_, 1992b 'Ceramic culinary moulds', in *Everyday and exotic pottery from Europe c 650-1900: studies in honour of John G Hurst*, by D Gaimster & M Redknap (eds), 290-302
- Nenk, B, Pearce, J, & Whittingham, L, in prep *Post-medieval pottery in London 1500-1700, 2: post-medieval redwares*
- Newton, E F, Bibbings, E, & Fisher, J L, 1960 'Seventeenth-century pottery sites at Harlow, Essex', *TEAS*, **25**, series 3, 358-77
- Nöel Hume, I, 1980 *A guide to the artifacts of colonial America*
- Orton, C, 1979 'Medieval pottery from a kiln site at Cheam: part 2, red ware', *The London Archaeologist*, **3** (no 13), 355-9
- Oswald, A, Hildyard, R J C, & Hughes, R G, 1982 *English brown stoneware 1670-1900*
- Pearce, J E, 1992 *Post-medieval pottery in London, 1500-1700, 1: Border wares*
- Pearce, J E, & Vince, A G, 1988 *A dated type-series of London medieval pottery, part 4: Surrey White wares*, TLMAS, Special Paper, **10**
- Pearce, J E, Vince, A G, & Jenner, M A, 1985 *A dated type-series of London medieval pottery, part 2: London-type ware*, TLMAS, Special Paper, **6**
- Pearce, J E, Vince, A G, & White, R, with Cunningham, C M, 1982 'A dated type-series of London medieval pottery, part 1: Mill Green Ware', TLMAS, **33**, 266-98
- Perkins, D R J, 1981 *The great storm wrecks*, East Kent Maritime Trust
- Petchey, M, 1976 'Gosfield, Kemps Wood', *EAH*, **8** (3rd series), 17-18
- Platt, C P S, 1976 *The English medieval town*
- Platt, C R, & Coleman-Smith, R, 1975 *Excavations in medieval Southampton 1953-1969, 2, the finds*
- Potter, S, 1990 'A lost pottery kiln at Purleigh rediscovered', *EAH newsletter*, **108**, 13
- Pryor, S, & Blockley, K, 1978 'A 17th-century kiln site at Woolwich', *Post-med Archaeol*, **12**, 30-85
- Rackham, B, 1972 *Medieval English pottery* (first published 1948)
- Rahtz, P A, 1969 'Medieval pottery', in *Excavations at King John's hunting lodge, Writtle, Essex, 1955-57*, Medieval Archaeol Monograph Series, **3**, 91-110
- Ray, A, 1968 *English Delftware pottery in the Robert Hall Warren Collection, Ashmolean Museum, Oxford*
- Reaney, P H, 1935 *The place-names of Essex*
- Redknap, M, 1983 'The pottery', in 'The western defences of the Inmost Ward, Tower of London', by G Parnell, TLMAS, **34**, 120-35
- \_\_\_\_\_, 1987a 'Recent work at Stratford, E15: 30 Romford Road', *The London Archaeologist*, **5** (no 11), 291-7
- \_\_\_\_\_, 1987b 'Continuity or change: the Mayen tradition from 4th-14th centuries', in Chapelot *et al* 1987, 87-99
- Reineking von Bock, G, 1971 *Steinzeug*
- Rodwell, W, 1976 'Some unrecorded archaeological discoveries in Essex, 1946-75: Bradwell-on-Sea', *EAH*, **8** (3rd series), 234-8
- Rogerson, A, & Dallas, C, 1984 *Excavations in Thetford, 1948-59 and 1973-80*, *EAA*, **22**
- Round, J H (ed), 1897 *Register of admissions to the Royal Grammar School of Colchester*
- SAS, 1990 *SAS/STAT user's guide version 6*, 4th edition, vols 1 & 2, SAS Inst Inc
- Sealey, P R, in prep 'Medieval finds from Wix', *EAH*
- Shenstone, J C, 1907 'Candied Eryngo', *Victoria County Histories Essex*, **2**, 371-2
- Shimmin, D, 1994 'Excavations at Osborne Street, Colchester', *EAH*, **25**, 46-59
- Sielmann, B, 1980 'Steinzeug aus Langerwehe', *Beitrage zur Keramik*, **1**, 26-33
- Sier, L C, 1943 'The Creffields of Colchester', *Essex Review*, **52**, 159-69
- Slowikowski, A, 1992 'The pottery from Stratton village, Biggleswade, and a nearby kiln at Everton, Bedfordshire', *Medieval Ceramics*, **16**, 70-71
- Smedley, N, & Owles, E, 1963 'Some Suffolk kilns: 4: Saxon



- kilns in Cox Lane, Ipswich, 1961', *Proc Suffolk Inst Archaeol*, **29** (part 3)
- Stenning, D F, 1994 'The Red Lion Hotel, Colchester', *EAH*, **25** (3rd series), 134-59
- Stephan, H-G, 1983 'The development and production of medieval stoneware in Germany', in Davey & Hodges 1983, 95-120
- Stephenson, D, 1978 *The book of Colchester*
- \_\_\_\_\_, 1985 'Colchester: a smaller medieval English Jewry', *EAH*, **16** (3rd series), 48-52
- Streeten, A D F, 1982 'Textural analysis: an approach to the characterisation of sand-tempered ceramics', in *Current research in ceramics: thin-section studies*, by I Freestone, C Johns, & T Potter (eds), BM Occas Paper, **32**, 123-34
- \_\_\_\_\_, 1983 *Excavations at Bayham Abbey*, Sussex Archaeol Soc Monograph, **2**
- \_\_\_\_\_, 1985 'Ceramic building materials and pottery', in *Battle Abbey: the eastern range and the excavations of 1978-80*, by J N Hare, HBMC Archaeol Rep, **2**, 79-126
- Thomson, R, 1986 'A post-medieval mercury jar', in 'Prehistoric settlement and the Romano-British "small town" at Heybridge, Essex', by N P Wickenden, *EAH*, **17** (3rd series), 53
- Thorn, J, 1979 'The pottery', in 'The excavation of the Hospital of St Mary of Ospringe, commonly called Maison Dieu', by G H Smith, *Archaeol Cantiana*, **95**, 154-83
- Trump, D H, 1961 'Blunt's Hall, Witham', *TEAS*, **1** (3rd series), 37-40
- van der Leeuw, S E, 1975 'Medieval pottery from Haarlem: a model', in *A contribution to medieval archaeology*, by J G N Renaud (ed), Rotterdam Papers, **2**, 67-87
- Verhaeghe, F, & Janssen, H L, 1984 'Early medieval Low Countries wares', in Allan 1984, 18-20
- Vince, A, 1984 'New light on Saxon pottery from the London area', *The London Archaeologist*, **4** (no 16), 431-9
- \_\_\_\_\_, 1985 'The Saxon and medieval pottery of London: a review', *Medieval Archaeol*, **29**, 25-93
- Vince, A, & Bell, R, 1992 'Sixteenth-century pottery from Acton Court, Avon', in Gaimster & Redknapp 1992, 101-112
- Vince, A, & Jenner, A, 1991 'The Saxon and early medieval pottery of London', in *Aspects of Saxon and Norman London 2: finds and environmental evidence*, by A G Vince (ed), LAMAS Special Paper, **12**, 19-119
- Wade, K, 1980 'The pottery', in Wade-Martins 1980, 413-78
- Wade-Martins, P, 1980 *North Elmham Park*, *EAA*, **9**
- \_\_\_\_\_, 1983 *Two post-medieval earthenware pottery groups from Fulmodeston*, *EAA*, **19**
- Walker, H, 1986 'Enough to you drive potty! Examples of pottery from Hole Farm kilns (Hedingham)', *Essex Archaeology*, **3**, 6, *Essex Chronicle* newspaper supplement
- \_\_\_\_\_, 1988a 'The pottery', in 'Maidens Tye: a moated site at High Easter', by E Sellers, P M Ryan, & H Walker, *EAH*, **19** (3rd series), 180-91
- \_\_\_\_\_, 1988b 'Medieval and post-medieval pottery', in 'Roman Coggeshall: excavations 1984-5', by C P Clarke, *EAH*, **19** (3rd series), 77-9
- \_\_\_\_\_, 1990a 'The medieval and later pottery', in 'Harwich: its archaeological potential as revealed in excavations at George Street and Church Street', by D D Andrews, B Milton, & H Walker, *EAH*, **21** (3rd series), 72-86
- \_\_\_\_\_, 1990b 'Pottery from a possible late medieval kiln dump at 77 High Road, Rayleigh', *EAH*, **21** (3rd series), 92-102
- \_\_\_\_\_, 1991a 'The medieval pottery', in 'Asheldham Camp — an early Iron Age hill fort: the 1985 excavations', by O Bedwin, *EAH*, **22** (3rd series), 29-31
- \_\_\_\_\_, 1991b 'The pottery', in 'Pentlow Hall', by D D Andrews, *EAH*, **22** (3rd series), 178-9
- \_\_\_\_\_, 1991c 'Medieval pottery', in 'Medieval pottery from Maplecroft, Sudbury Road, Castle Hedingham', by D Priddy, *EAH*, **22** (3rd series), 175-6
- \_\_\_\_\_, 1991d 'The medieval and later pottery', in 'An archaeological sequence at the edge of Old Harlow market place', by D D Andrews, *EAH*, **22** (3rd series), 108-112
- \_\_\_\_\_, 1992a 'Medieval coarse-ware pottery', in 'Medieval finds from the Post Office, High Street, Maldon', by M R Eddy, H J Major, & H Walker, *EAH*, **23** (3rd series), 148-9
- \_\_\_\_\_, 1992b 'Medieval pottery', in 'Two rural medieval sites in Chignall St James: excavations 1989', by H Brooks, *EAH*, **23** (3rd series), 46-8
- \_\_\_\_\_, 1995 'The medieval and post-medieval pottery', in *Excavations at North Shoebury: settlement and economy in south-east Essex 1500 BC-1500 AD*, by J J Wymer & N R Brown, *EAA*, **75**, 102-124
- \_\_\_\_\_, 1996a 'Medieval and post-medieval pottery', in 'A medieval farm and its landscape: excavations at Stebbingford, Felsted 1993', by M Medlycott, *EAH*, **27**, 127-51
- \_\_\_\_\_, 1996b 'Medieval pottery', in 'Medieval and post-medieval remains from Thaxted: excavations at the rear of 23 Town Street 1992', by M Medlycott, *EAH*, **27**, 332-5
- \_\_\_\_\_, forthcoming (a) 'The medieval and later pottery', in 'Excavations at Maldon Friary 1990-91', by R M J Isserlin, *EAH*
- \_\_\_\_\_, forthcoming (b) 'The medieval and later pottery', in 'The archaeology of the A133 Clacton to Weeley scheme: Gutteridge Hall', by A G Wade, *EAH*
- Wallis, S, 1992 'Horndon-on-the-Hill, Mill Lane/High Road corner', in 'Archaeology in Essex 1991', by P J Gilman (ed), *EAH*, **23** (3rd series), 106
- Ward, J C, 1983 *The medieval Essex community: the Lay Subsidy of 1327*, ERO, Essex Historical Documents, **1**
- Webster, L E, & Cherry, J, 1972 'Medieval Britain in 1971', *Medieval Archaeol*, **16**, 147-212
- \_\_\_\_\_, 1973 'Medieval Britain in 1972', *Medieval Archaeol*, **17**, 138-88
- \_\_\_\_\_, 1974 'Medieval Britain in 1973', *Medieval Archaeol*, **18**, 174-223
- \_\_\_\_\_, 1979 'Medieval Britain in 1978', *Medieval Archaeol*, **23**, 234-78
- Wickenden, N, forthcoming 'Polygonal chimney bricks in Essex, including a neutron activation analysis study', *EAH*
- Willan, T S, 1938 *The English coasting trade 1600-1750*
- Williams, D F, 1984 'The petrology of the olive jars and Merida-type wares', in Allan 1984, 145
- Williams, F, 1977 *Excavations at Pleshey Castle*, *BAR*, **42**
- Williams, J H, 1979 *St Peter's Street, Northampton. Excavations 1973-1976*
- Wilson, D M, & Hurst, J G, 1958 'Medieval Britain in 1957', *Medieval Archaeol*, **2**, 183-213
- \_\_\_\_\_, 1959 'Medieval Britain in 1958', *Medieval Archaeol*, **3**, 295-326
- Wilson, D M & Hurst, D G, 1965 'Medieval Britain in 1964', *Medieval Archaeol*, **9**, 170-220
- Wilson, M G, 1982 'The pottery', in Bennett *et al* 1982, 66-9

# Index

- A**  
Aachen 278, 281  
Aachen stoneware 281-2  
Aardenburg 270  
Acton Court, Somerset 308  
*albarelli* 229, 232, 308  
Albinia, Italy 308  
alchemy 6, 328, 334  
Alderney 234  
Aldgate, London 229  
Aldham, Essex 178, 180  
Alembics 4, 7, 156, 232, 290  
Alentejo, Portugal 297  
Alfred the Great 17  
All Saints' parish 366  
almshouses 6, 323  
Alresford, Essex 178  
Amiens 18  
amphoras 296, 308  
Amsterdam 287  
Ancient Monuments Laboratory 30, 308  
Andalusian lustreware 13, 294-5, 363  
Andenne 265, 266  
Andenne ware 5, 9, 12, 33, 36, 266, 353, 362  
Andries,  
    Jasper 229, 366  
    Lucas 234  
Angel Inn, the 10  
    see also Angel Yard excavation  
Angel Yard excavation xiv, 10, 30-31, 55, 74,  
    79, 100, 104, 108, 129, 146, 152, 156,  
    159, 161, 163-5, 168, 187-9, 203, 210,  
    215, 228, 243, 249, 264, 282, 303-4,  
    334  
Anglo-Saxon  
    cemetery near Mersea Road 24  
    huts see huts, Anglo-Saxon  
    occupation in Colchester 1, 39, 353-6  
Anglo-Saxon pottery, early to mid 4, 7, 9, 10,  
    12, 17, 20-21 see also Fabrics 2-4, 97  
antler-working debris 4  
Antwerp 229, 232, 234, 274  
apothecaries 3-7, 203, 209-210, 228-32, 234,  
    237, 244, 280, 290, 297, 328, 334, 337  
*aquamaniles* 6, 73-5, 83, 87, 91, 156, 188  
archaeomagnetic dates 41-2, 50  
Archer, Michael xiv, 228, 235  
archive 11-13, 250, 254, 357  
Ardleigh, Essex xiv, 17, 123, 128, 177-8,  
    191-2, 203, 207, 210, 359, 365, 367-8  
    parish of 367-8  
Ardleigh Reservoir, Essex 368  
Ashdown, J 301, 304  
Asheldham, Essex 71  
Asheldham Camp, Essex 35  
Astbury, Thomas 253  
Astbury-type earthenware 250  
Asthall-type bottle 27  
Asturias, Portugal 298  
Athelstan, king 17  
auricula pots 368, 369
- B**  
Baconsthorpe Castle, Norfolk 232  
Badorf-type ware 12  
Bailey, Richard 256  
Balcerne Lane excavation 22, 106, 246, 303-4  
    overview of excavation 9  
Ball, John 19, 322  
baluster jugs 72-3, 77, 79, 91, 101, 109,  
    112-18, 122, 124, 126-9, 146, 150, 168,  
    173-6, 181, 186, 219, 262, 320, 322,  
    354  
bar charts, explanation 16  
Barnston, near Great Dunmow 166, 177-8,  
    180, 360  
Barrington, Cambs 79, 86, 89  
*Bartmann* jugs 232, 246, 280, 284-7  
    see also bellarmines  
Barton Mounts 89  
Basalt ware 13, 252-3  
Battle Abbey, Sussex 164, 308  
Bay of Bourgneuf 18, 258  
Bayham Abbey, Sussex 308  
beakers, laboratory 290  
Beaumont-cum-Moze, Essex 89, 300, 301,  
    304  
Beauvais earthenwares 13, 260, 262-4, 362  
Beauvais sgraffito 362  
Beauvais stoneware 13, 263, 362  
Bedford 33, 293  
bed-warming pan 217  
*Beerlegem* bowls 258  
bellarmines 247, 287, 344  
    see also *Bartmann* jugs  
bell, casting 10, 41  
Benham, W G 364  
Bensusan-Butt, John xiv, 230, 250, 364, 368  
Berechurch, parish of 364  
Bergen-op-Zoom 90, 267  
Beverley, ER Yorks 18  
Beverley ware 75, 355  
Bingham, Edward 191  
bird feeder 228  
bird pot 217-18  
Birmingham Museum 237  
Bishops Stortford, Herts 90, 177  
Bitossi, Vincenzo 304  
Bitosso, Carlo 304  
Black Death 18  
Blackmore End, Essex 90, 109  
bleeding bowls 243  
Blind Knights, Abberton, Essex 93  
Blue-grey ware see Paffrath-type ware  
Blunt's Hall, Witham, Essex 37, 69  
Bocking, Essex 177-8, 359  
Border ware 10, 13, 154, 170, 176-7, 183-4,  
    193-4, 203, 210, 212, 225-8, 232, 235,  
    274, 308, 343, 351, 355, 361  
Boston, Lincs 18  
bottles 12-13, 19, 27, 101, 104-5, 112, 154-5,  
    177, 212, 228, 230, 232, 234, 244-7,  
    254-6, 258, 260, 264, 287, 293, 334,  
    353, 357  
Bourchier's Hall, Aldham, Essex 166, 360  
Bow china 251  
Boxted, Essex 303  
Brabant, Holland 366  
Bradfield St Clare, Essex 89  
Bradwell-on-Sea, Essex 89, 178  
Brain Valley, Essex 36-7  
Braintree, Essex 89-90, 109, 122, 129, 134,  
    141, 154, 177, 191, 307, 363  
Braintree ringers' jar 210  
Bramford, Suffolk 101, 115  
Brandsby-type ware 75  
bread crocks 207  
Bremen 292  
brewing 203  
bricks  
    Dutch 265  
    imports 19  
brick kilns  
    see kilns, brick  
brickmakers/brick-making  
    Ardleigh 203, 368  
    Berechurch 364  
    Colchester 364  
    Dedham, parish of 368  
    Dilbridge 365  
    Kingswood Heath 365  
    Mile End 365  
Brill, Bucks 141  
brining trough 214-15  
Bristol 18, 248  
Broomfield, Chelmsford 258  
Brunssum-Schinveld ware 12, 265-6, 362  
Buckstone, Thomas 230  
Budd, Paul 308  
Building 28 5-6, 55, 101-2, 111-12, 281, 296,  
    334  
Building 29 5-6, 111, 141, 165  
Building 30 6  
Building 31 6, 323  
Building 32 6  
Building 33 6  
Building 74 8, 47, 56-7, 67, 92, 126  
Building 75 8, 55, 57, 67, 164-5, 219-20, 344  
Building 76 8, 97, 129, 219, 344  
Building 128 6-7  
Building 129 7, 328  
Building 130 8  
Building 149 8-9, 322  
Building 150 8-9  
Building 151 8-9, 334  
Building 156 9  
Building 157 9  
Building 158 9  
buried pots 8, 98, 129, 221, 361  
Bury St Edmunds, Suffolk 89  
Bush, Richard 219  
Butcher, George 191  
Butt Road excavation 10, 306, 363  
butter pot 227  
Buxstone, Thomas 230  
Buxton, apothecaries 5  
Buxton,  
    Robert 230, 232, 290, 334, 337  
    Thomas 232
- C**  
Caerleon, Newp 296  
Calais 18  
Calver, H C 307, 359  
Cambridge 82, 89-91, 356  
candle-holders 159  
candlemaker's troughs 156, 159, 177, 180  
candlesticks 252, 254  
Canterbury 69, 71, 108, 134, 210, 222, 293,  
    296, 307  
Canterbury Cathedral 70, 115  
Canterbury wares 70  
Canvey Island, Essex 89  
*capuchines* 247, 253  
Carmarthen, Carmes 296  
Carolingian vessels 17, 186  
casseroles 214-15  
Castle Camps, Cambs 89  
Castle Hedingham, Essex 89  
Cat Lane 3, 230  
cauldrons 112, 138, 176, 183, 187-8, 191-2,  
    203, 207-8, 210, 219-20, 267-70, 274,  
    325  
cellars, stone in Colchester 8  
ceramic phasing 11, 15  
Cestrewald 367  
chafing dishes 83-4, 109, 194, 214, 227-8,  
    260, 262, 325, 334  
chamberpots 4, 97, 203, 206-8, 225, 227,  
    244, 254, 287-9, 344  
Chapman and André, map 369  
chargers 4, 194, 230, 237-9, 292, 296, 334,  
    344  
Cheam copy 122, 124, 128-9, 173, 177  
Cheam ware 109, 322

- Cheam white ware 13, 122, 128-9, 173, 176-7, 183-4, 325, 360  
 cheese presses 154, 215-16  
 cheese-making 215  
 Chelmsford 20, 76, 83, 89-91, 109, 150, 159, 163-5, 168, 177-8, 180, 182, 188-9, 191, 203, 212, 218, 222, 284, 331, 368, 370  
 Chelmsford Dominican Priory 186  
 Chequers Hotel site, Maldon 92  
 Chichester, W Sussex 166  
 chicken feeders 193, 227-8  
 Chignall St James, Chelmsford 115  
 childrens' toys 254  
 Childwell 110  
 chimney coping 106  
 chimney pots 56, 106, 159, 369  
 Chinese porcelain 13, 194, 237, 243, 254, 296-7, 306, 351  
 Church Walk 301, 363  
 churches, Colchester 1  
   Anglo-Saxon 10  
   Holy Trinity 17  
   St Giles' 10, 41  
   St John's 10, 15, 31, 41, 52, 357  
   St Nicholas' 20, 28, 31, 230  
 Churchill, Oxon 134  
 Cibly, Belgium 258  
 Cistercian ware 13, 122, 149, 177, 184-5, 328, 360  
 cisterns 7, 56, 101, 104-5, 108-110, 118, 122, 127, 129-30, 134, 138, 141, 168, 174, 176-7, 180, 183, 192-3, 202-3, 370-71  
 Civil War fort at Sheepen, Colchester 3, 218-19  
 Clarke, D T-D 219, 307  
 classification of Essex post-Roman pottery 21  
 clay-digging 110  
 clay-pipe manufacture in Colchester 19  
 clay pipes 4, 8, 14, 194, 212, 218, 222, 225, 232, 234, 237, 243, 245, 247, 252, 270, 284, 287-8, 292, 306, 331, 334, 337, 344  
 clay stoves 366  
 cloth trade in Colchester 19, 90, 215, 230, 258, 277, 294, 299, 355, 366  
 cloth-working 8  
 Coarse Border ware 13, 176, 183  
 coastal trade at Colchester 18  
 Coggeshall, Essex 89, 177-8, 300  
 coin hoards 18, 141  
 coins 1, 5, 7, 9, 14-15, 31, 33, 55, 67, 84, 92, 94, 96, 98, 104, 106, 112-13, 128, 138, 154, 164, 180, 182-3, 212, 215, 218, 222, 225, 232, 235, 244, 260-62, 267, 284, 287, 292, 316, 325, 328, 334, 337, 353  
 colanders 154, 215  
 Colchester  
   as a port 17  
   charter 18  
   cloth industry 18  
   hospitals 17  
   medieval, description of 17  
   post-medieval, description of 19  
   Roman 17  
   Saxon, description of 1, 17  
 Colchester Castle 1, 4, 17-18, 19, 20, 297-8, 367  
   excavations in bailey and of bailey defences 20, 31, 33, 36, 41-2, 51, 70, 102, 122, 150, 152, 154, 164, 276, 297-8  
 Colchester ceramic phasing 11, 15  
 Colchester Museum xiv, 1, 13, 20, 26, 37, 44, 73-5, 77, 90, 100, 102, 104, 110, 118, 122, 130, 143, 146, 154, 156, 159, 166, 168, 177, 183-4, 191, 193, 203, 210, 212, 215, 228, 230, 247-8, 258, 262, 264, 270, 280, 287-8, 296, 300, 303-4, 307, 357  
 Colchester Natural History Museum 230  
 Colchester Public Records Office xiv  
 Colchester Royal Grammar School 230  
 Colchester russet 18  
 Colchester 'slip-painted' ware 12, 108  
 Colchester town-centre, post-Roman cultivation 3, 6, 7, 8, 10  
 Colchester-type ware xiv, 5-6, 9-10, 12, 19, 20, 57, 67, 72-3, 89, 92, 94, 101, 104, 106-180, 182, 184, 188-9, 192, 203, 207, 212, 219, 232, 316, 320, 325, 328, 354-6, 359-60, 367, 369-70, 372-3  
 Cologne 276-8, 282, 287  
 Cologne and Frechen stonewares 5, 280-88, 362  
   see also Cologne stoneware and Frechen stoneware  
 Cologne stoneware 13, 143, 149, 232, 246, 267, 280-82, 284, 328, 355  
 Colonel Ewer's fort 219  
 combs 25, 311  
 concordance of illustrated pottery 357-63  
 condiments 143, 168, 192, 212, 214, 227-8  
 Coney, Joseph 251  
 coolers 221  
 Copford, Essex 89  
 Cork, Ireland 186  
 costrels 13, 28, 30, 32, 83-4, 112, 154, 177, 212, 214, 227-8, 262-3, 278, 280, 282, 283, 295, 297, 300, 363  
 Cotswolds-type oolitic ware 39  
 Court Rolls, Colchester 19, 110, 134, 265, 322, 364-6  
 Coutts, Catherine 258  
 Cove, Hamps 170  
 Covehithe, Suffolk 89-90, 177, 178  
 Coventry 308  
 Creamware 13, 250-54, 288, 306  
 Creffield, Ralph 230  
 cresset lamps 56  
 Cressing Temple, Essex 37, 89, 178, 307  
 Crockleford Heath, Essex 367  
 Crouch Street 10, 228, 262, 360  
 Crouch Street excavation 10  
 Crouched Friars 10, 228  
 Crouchman, Thomas 366  
 crucibles 4, 22, 28, 30, 32, 55, 56, 230, 288, 290, 334, 363  
 cruets 112, 154  
 Crummy, Nina xiv, 365  
 Crummy, Philip xiv, 17, 20-22, 24-6, 31, 310  
 cucurbits 104, 156  
*Cuerda Seca* 5, 13, 295-7, 363  
 Culver Street excavation 1, 3, 4-8, 10, 22, 24-5, 30-31, 39, 54, 56, 84, 130, 163, 165-6, 230, 281, 293, 310-11, 334, 359-60  
   overview of excavation 6  
 Cunningham, Carol xiv, 10, 12, 20-21, 90, 108, 177  
 cups 4-5, 8-10, 17, 26, 83-4, 89, 109, 118, 149-50, 168, 170, 184-5, 189, 203, 212-13, 219, 222-3, 230, 232, 243, 247-8, 251, 253-4, 270, 278-80, 282-3, 325  
 Cups Hotel excavation 1, 9, 17, 24, 26-7, 31, 33, 37, 39, 83, 86, 104, 129, 182, 311  
   overview of excavation 9  
 Cups Hotel, the 9  
 curfews 35, 52, 54-5, 64-8, 92, 104-5, 141, 154, 156, 270, 272-4, 316
- D**  
 Damascus 18  
 Danbury, Essex 94, 101, 109, 364  
 Danes in Colchester 17, 26, 31, 353  
 dark earth 6, 23  
 David, Abbot of St Osyth's 365  
 Dawson, G J 188  
 de Both, Antony 280  
 de Estorpe, William 308  
 de Groot, Samuel 230  
 de Saaham, William 308  
 Deal, Kent 301  
 Dedham, Essex 191, 193, 307, 368  
 Dedham, parish of 368  
 Dedham Heath, Essex 368  
 Delft tiles 251  
 Denby, Derby 254  
 Dengie peninsula, Essex 35  
 Denham, Bucks 69-70  
 Denny, Cambs 90  
 Denny Abbey 76, 83-4, 89, 176-7  
 Dieppe 264  
 Dilbridge (Greenstead parish) 365-6  
 Dinna Clerks, Dartmoor 129  
 dishes 22, 35-6, 72, 91, 129, 142-3, 150, 152, 154-6, 168, 175-7, 188, 191-6, 201, 212, 214-15, 222-30, 232, 234-40, 242-4, 248-9, 253-6, 260, 262-3, 267, 269-71, 274, 282, 290-92, 294-5, 297, 299, 303, 306, 310, 325, 334, 344, 351  
 distilling 6-7, 104, 232  
   bases 156  
   equipment 156, 180  
 documentary sources xiv, 1, 191, 250-51, 355, 364-8  
 Domesday Book 17, 69, 258, 353  
 Dorant, Edward 368  
 Dover, Kent 258  
 Dovercourt, Essex 89  
 Downs, Christopher 367  
 drain-pipes 105-6, 191  
 Dreihausen, Hesse 280  
 Drey, R E A 244  
 drinking vessels 5, 7, 118, 149, 177, 184, 191, 212, 219, 232, 247, 270-71, 281, 344, 355  
 dripping pans 65, 82-3, 86, 104-5, 156, 215-16, 270-71, 368  
 drug jars 6, 210, 225, 227-30, 232-7, 244-5, 254, 274, 290, 295, 299, 331, 334, 337  
 Duck Lane, Canterbury 221  
 Duisburg, Germany 228  
 Duke of Norfolk 19, 281, 367  
 Dunnett, B R K 22  
 Dunning, G C xiv, 33, 164, 166, 170, 265  
 Dunwich, Suffolk 110  
 Dutch community in Colchester 18-19, 191, 203, 215, 230, 265, 366  
 Dutch ovens 224-5  
 'Dutch Quarter', the 165  
 Dutch slipware 8  
 Duxford, Cambs 71  
 Dwight, John 246
- E**  
 early medieval chalky ware 70  
 early medieval sandy shelly wares 36  
 early medieval sandy wares 5, 9, 12, 26, 35-6, 39-70, 84, 86, 91-2, 94, 96, 98, 100, 102, 108, 111-12, 124, 174, 189, 316, 320, 344, 353, 357-8  
 early medieval shell-dusted sandy ware 39-40, 47, 49, 50-51, 68, 70, 111, 353, 357  
 early medieval shelly wares 12, 34, 36-7, 40, 67  
 early medieval shelly wares without sand 34-7, 41, 71, 354, 357  
 early medieval slightly sandy shelly wares 35-6, 357  
 early medieval transitional sandy ware 39-40, 47, 49-52, 55-7, 91-2, 98, 101, 104, 106, 134, 357-8  
 early medieval wares 40  
 earthenware pipes 368-9  
 East Anglian redwares 109  
 East Donyland, parish of 368  
 East Hill 360, 366  
 East Stockwell Street 163-4, 360  
 East Stockwell Street excavation, nos 31-6 159  
 Eaton Socon, Beds 39  
 Edmund, king 17  
 Edward the Elder 17, 26  
 Eld Lane 5-6  
 Elmdon, Essex 70  
 Elmstead, Essex 193  
 Ely, Cambs 90  
 Emens, James 282  
 Ems, Germany 293  
 English porcelain 13, 252, 254  
 English stonewares 13, 245-7, 252, 254, 362  
 Erith, Felix xiv, 191, 368  
 erylgo-roots 230  
 Essex and East Anglian redwares 109, 354  
 Essex post-Roman pottery codes 12  
 Essex Record Office 364  
 Essex redwares 109  
 Evererd, John 232  
 Evison, Vera 258  
 excavation policy for post-1700 deposits 250

- Exeter 277, 294, 296  
 Exning, Suffolk 89  
 Ezine, Turkey 308
- F**
- Fabrics 1, 1B, 1C *see* vegetable-tempered ware  
 Fabric 8 *see* Ipswich ware  
 Fabric 8V 27, 260, 357  
 Fabric 9 *see* Thetford-type wares  
 Fabric 10 *see* St Neots-type ware  
 Fabric 11A *see* Stamford ware  
 Fabric 12 *see* early medieval shelly wares  
 Fabric 12A *see* early medieval shelly wares without sand  
 Fabric 12B *see* early medieval slightly sandy shelly wares  
 Fabric 12C *see* early medieval sandy shelly wares  
 Fabric 12D *see* oolitic wares  
 Fabric 13 *see* early medieval sandy wares  
 Fabric 13S *see* early medieval shell-dusted sandy ware  
 Fabric 13T *see* early medieval transitional sandy ware  
 Fabric 14A *see* Pingsdorf-type ware  
 Fabric 14B *see* Brunssum-Schinveld ware  
 Fabric 17 *see* Andenne ware  
 Fabric 17X *see* miscellaneous early medieval Low Countries white wares  
 Fabric 18 *see* Paffrath-type ware  
 Fabric 20 *see* medieval sandy greywares  
 Fabric 20A *see* Mile End (Colchester) coarseware  
 Fabric 20C *see* Mill Green coarseware  
 Fabric 20D *see* Hedingham coarseware  
 Fabric 21 *see* medieval sandy orange wares  
 Fabric 21/40 118  
 Fabric 21A *see* Colchester-type ware  
 Fabric 21B *see* Colchester 'slip-painted' ware  
 Fabric 22 *see* Hedingham ware  
 Fabric 23 *see* medieval white wares  
 Fabric 23C *see* Low Countries white earthenwares  
 Fabric 23D *see* Kingston-type ware  
 Fabric 23E *see* Cheam white ware  
 Fabric 23F *see* Coarse Border ware  
 Fabric 24, 24A, 24B *see* Scarborough ware  
 Fabric 24X *see* Yorkshire wares  
 Fabric 27 *see* Saintonge ware  
 Fabric 28 *see* Rouen-type ware  
 Fabric 29A *see* olive jars  
 Fabric 29X *see* miscellaneous Iberian green glazed wares  
 Fabric 30 *see* Beauvais earthenwares  
 Fabric 31 *see* Low Countries red earthenwares  
 Fabric 31A *see* North Holland slipware  
 Fabric 35 *see* Mill Green ware  
 Fabric 36 *see* London-type ware  
 Fabric 39 *see* North Italian marbled slipware  
 Fabric 40 *see* post-medieval red earthenwares  
 Fabric 40A *see* Metropolitan slipwares  
 Fabric 40C *see* Cistercian ware  
 Fabric 40D *see* Wrotham slipware  
 Fabric 40E *see* Sussex inlaid slipware  
 Fabric 41 *see* Tudor Green ware  
 Fabric 42 *see* Surrey/Hampshire Border white ware  
 Fabric 43 *see* Martincamp flasks  
 Fabric 44 *see* German slipwares  
 Fabric 44A *see* Weser slipware  
 Fabric 44B *see* Werra slipware  
 Fabric 44C *see* Lower Rhine slipware  
 Fabric 45 *see* English stoneware  
 Fabric 45A *see* Langerwehe stoneware  
 Fabric 45B *see* Siegburg stoneware  
 Fabric 45C *see* Raeren stoneware  
 Fabric 45D *see* Frechen stoneware  
 Fabric 45E *see* Cologne stoneware  
 Fabric 45F *see* Westerwald stoneware  
 Fabric 45G *see* Nottingham/Derbyshire stoneware  
 Fabric 45J *see* Beauvais stoneware  
 Fabric 45K *see* Gothic (Saxony) stoneware  
 Fabric 45M *see* modern English stoneware
- Fabric 45N *see* Normandy stoneware  
 Fabric 45S *see* Nieder Selters-type bottles  
 Fabric 46 *see* tin-glazed earthenware  
 Fabric 46B *see* Spanish lustrewares  
 Fabric 46B/1 *see* Andalusian lustrewares  
 Fabric 46B/2 *see* Valencian lustrewares  
 Fabric 46C *see* South Netherlands *maiolica*  
 Fabric 46D/1 *see* *Cuerda Seca*  
 Fabric 46D/2 *see* Seville *maiolica*  
 Fabric 46E *see* Italian Montelupo *maiolica*  
 Fabric 46F *see* Portuguese *maiolica*  
 Fabric 47 *see* Staffordshire-type white stoneware  
 Fabric 48 *see* porcelain  
 Fabric 48A *see* Chinese porcelain  
 Fabric 48B *see* English porcelain  
 Fabric 48C *see* Creamware/ Queensware  
 Fabric 48D *see* Staffordshire-type white earthenwares  
 Fabric 48E *see* Yellow ware  
 Fabric 48J *see* Jackfield ware  
 Fabric 48L *see* lustre ware  
 Fabric 48R *see* Red stoneware  
 Fabric 48V *see* sanitary wares  
 Fabric 48W *see* Whieldon-type wares  
 Fabric 48X *see* miscellaneous earthenwares  
 Fabric 49 *see* Basalt ware  
 Fabric 50 *see* Staffordshire-type slipware  
 Fabric 50A *see* Staffordshire-type iron-streaked earthenware  
 Fabric 51A *see* slipped kitchenware  
 Fabric 51B *see* flowerpot  
 Fabric 52 *see* Mediterranean 'mercury' jars  
 Fabric 53 *see* Iberian storage jars  
 Fabric 54 *see* Italian oil jars  
 Fabric 55 *see* Guy's-type ware  
 Fabric 56 *see* North Devon gravel-tempered ware  
 Fabric 57 *see* Merida-type ware  
 Fabric 58 *see* Martabani stoneware  
 Fabric 60 *see* Hessian crucibles  
 Fabric 62 *see* Iberian/North African star costrels  
 Fabric 95 *see* unidentified foreign wares  
 Fabric 95M *see* unprovenanced French micaceous ware  
 Fabric 95P *see* Pudding Lane-type North French glazed ware  
 Fabric 97 21-3, 258, 310  
*see also* Saxon brickearth fabrics (Fabrics 2-4C)  
 Fabric 97F *see* wheel-thrown Frankish sandy wares  
 Fabric 98S *see* non-local slip-painted ware  
 Fabric 98W *see* Long Wyre Street ware
- fabric descriptions, Department of Urban Archaeology, London 13  
 fabrics and wares, terms 12  
 Falcon Inn, the 9, 129  
 Falke group 280  
 Far Eastern wares 306  
 Faversham, Kent 19, 247, 258  
 Feddersen Wierde 310  
 Feering, Essex 81, 89  
 Fen Ditton, Cambs 176  
 Finch, George 191  
 finials 106, 364  
 fire-covers 55, 104, 154  
 firepots 215-16  
 fishing 18  
 Flanders tile 18  
 Fleece public house, the 247  
 Florence, Italy 299, 305  
 flower blocks 159  
 flower vases 274, 275, 328, 331  
 flowerpot 13, 189, 191, 215-17, 252, 256, 369  
 Fordham, Essex 89  
 Foulness, Essex 369  
 Framlingham, Suffolk 89  
 Frankish pottery 9, 13, 17, 27, 258, 260, 354, 362  
 Frechen 282  
 Frechen stoneware 5, 13, 113, 149, 232, 246, 280-81, 284, 355, 362  
 French wares 258-64, 353, 355  
 French white wares 274  
 Frinton, Essex 92, 359
- frying pans 54, 104, 143, 316  
 Fulham, London 246  
 Fulmodeston, Norfolk 193, 210, 217  
 fuming pots 154, 173
- G**
- Gaimster, D R M xiv, 228, 280  
 Gainsborough 19, 251  
 Gallipoli, Italy 305  
 gaming counters 56, 106  
 garden jars 207, 301, 304  
 Gascony 18, 258  
 George Hotel, the 247  
 German and Rhenish wares 6, 15, 270, 276-93  
*see also* Fabrics 14A, 18, 44A, 44B, 44C, 45A, 45B, 45C, 45D, 45E, 45F, 45K, 45S, 60  
 German slipwares 8, 13, 194, 290-93  
*see also* Fabrics 44, 44A, 44B, 44C  
 Gestingthorpe, Essex 192, 210  
 Gestingthorpe Pot Works 191  
 Gilberd School excavation 10, 15, 40-41  
 ginger jars 306  
 Glaphorn, Northants 141  
 glass 1, 4, 7, 18-19, 104, 156, 230, 232, 245, 250, 258, 261, 266, 290, 323, 328, 334  
 Glide, Thomas 368-9  
 Goldhanger Mill, Essex 369  
 Goodwin Sands 301  
 Gosfield, Essex 49, 77, 89, 93  
 Gothic (Saxony) stoneware 5, 13, 280-81, 355, 362  
*Gotisches Steinzeug* 280  
 grain-drying oven, Roman 24-6  
 gravel pits 7, 9  
 Gray  
 Charles 298  
 George 230  
 Great Easton, Chelmsford 89, 113, 163, 164-5, 177-8, 180  
 Great Fire of London 237, 344  
 Great Horkeley, Essex 12, 92, 98, 108-110, 134, 174, 178, 191, 367, 370-73  
 Great Horkeley, parish of 367  
 Great Horkeley industry 94  
 Great Sampford, Essex 89  
 Great Wigborough, parish of 369  
 Great Yarmouth, Norfolk 69, 290  
 Great,  
 Charles 232  
 Samuel 230, 232  
 Thomas 230, 232  
 Greenstead, parish of 364-7  
 Grimston, Norfolk 87  
 Grimston ware 13, 75, 87, 90, 152, 176  
 Grossalmerode, Germany 290  
 Grub Street 9  
 Gujerat, India 298  
 Guthrum 17  
 Gutteridge Hall, Weeley, Essex 146  
 Guy's-type ware 13, 122, 187-9, 267, 270, 328, 331, 334, 343, 360
- H**
- Hacch, Richard 366  
 Hadleigh Castle, Essex 37, 69, 128, 143, 164-5, 168, 170, 176  
 Halstead, Essex 75, 109  
 Hampton Court 190  
 Hamwic, Southampton 258  
 Hanchurch, Staffs 251  
 Hanse, German merchants of the 277  
 Hanworth, London 190  
 Harling, Norfolk 89  
 Harlow, Essex 109-110, 370  
 Harlow ware 12, 175, 370, 372  
 Harmignies, Belgium 258  
 Harper, Thomas 366  
 Harrold, Beds 39  
 Hartford, Cambs 141  
 Hartley, D 305  
 Hartlip, Kent 308  
 Harwich, Essex 17, 37, 76, 82, 87, 89-90, 92, 150, 152, 177-8, 258, 307, 355  
 Haslingfield, Cambs 176

- Hassells, John, William, and Richard 251  
 Haverhill, Suffolk 89  
 Head Street 6-8, 17, 212, 247, 262, 299-300, 358-60  
 heating trays 22  
 Hedingham, Essex 75, 109, 191  
 Hedingham coarseware 12, 41, 69-71, 86, 92-3, 104  
 Hedingham industry 75, 92  
 Hedingham ware 5, 7-8, 12, 14, 31-2, 36-7, 55, 57, 67, 69, 72-3, 75-92, 100-102, 112, 122, 124, 126-7, 134, 146, 150, 174-5, 177, 182, 262, 315-16, 320, 322, 353-4, 356, 358  
 Henry III 18  
 Hesse, Germany 290  
 Hessian crucibles 13, 288, 290, 363  
 Heybridge, Essex 21, 24, 164, 178, 180, 307-8, 310  
 High Easter, Essex 89, 177-8  
 High Street 1, 3-5, 9-10, 17-20, 26-8, 30-31, 40-41, 55, 110, 129, 156, 182, 230, 232, 247, 250-51, 290, 303, 311, 353, 357-9, 366  
 Highfield Farm, Bures 69  
 Hill, Catherine 310  
 Hillborough, Norfolk 89  
 Hilly Fields 218  
 Hollisley, Suffolk 109  
 Hollytrees Museum 301, 363  
 Horkesley Heath 110, 367  
 Horndon-on-the-Hill, Essex 89  
 Horningsea, Essex 81-2, 89  
 Horsman's Place, Dartford, Kent 176  
 Howard  
 Lord John 4-5, 110  
 Lord Thomas 4  
 Howedon, John 230  
 Hughes, M J 296, 301, 370, 372  
 Hull, M R 18-19, 20, 219, 251  
 Hume, Noël 301  
 Hurman, Barbara xiv, 161  
 Hurst, John G xiv, 20, 90, 263, 296, 298, 306  
 huts, Anglo-Saxon 1, 3, 17, 22, 23, 353  
 Hut 1 6, 21, 23, 25, 310-11  
 Hut 2 6, 21-5, 260, 309-310  
 Hut 3 7, 25, 39, 310-11  
 Hut 4 7  
 Hythe, The 17, 18, 104, 251, 265, 277, 366  
 Hythe Hill 359
- I**  
 Iberian/North African star costrels 13, 295, 297, 363  
 Iberian storage jars 13, 297-8  
 Iberian wares 294-8  
 see also Fabrics 29A, 29X, 46B, 46B/1, 46B/2, 46D, 46D/1, 46D/2, 53, 62  
 Ifield, Henry 247  
 industrial vessels 6, 104-5, 120, 124, 129, 141, 154, 156  
 Ingatestone, Essex 109  
 Ingatestone Hall, Essex 207, 218  
 nk wells 159, 180  
 inscriptions, on pottery vessels 168, 170  
 Inworth, parish of 369  
 Ipswich v, x, 9, 12, 17-19, 24-6, 28, 30-32, 40, 69, 86, 89-91, 177-8, 191, 248, 251, 254, 258, 277, 301, 353-4, 356-7  
*Ipswich Journal* 250-51  
 Ipswich Thetford-type wares 30  
 Ipswich ware 9, 12, 17, 25-7, 32, 353-4, 357  
 iron-working 3  
 ironstone pottery 253  
 Italian Montelupo *maiolica* 5, 299, 363  
 Italian oil jars 13, 300-305, 363  
 Italian wares 299-305  
 Iznik, Turkey 308
- J**  
 Jackfield, Shrops 252-3  
 Jackfield ware 13, 252-3  
 Jacob, Janson 229  
*Jacobakannen* 280, 282  
 Jasper ware 253  
 Jeayes, I H 364
- Jewish community in Colchester 4, 5, 18, 165, 166  
 John Rayner's tile works 191
- K**  
 Karlsbad springs, Bohemia 293  
 Keeling, Antony, factory 251  
 Keeling, John 251  
 Kelly's Directory 248  
 Kelvedon, Essex 89  
 kiln-furniture 55-6, 191, 225, 368-9  
 kilns  
 brick 191, 366  
 Lexden 364  
 Sible Hedingham 191  
 clamp 40  
 lime 3-4, 6-7, 10, 40, 44, 146, 323  
 Roman 367  
 tile 109-110, 191, 217, 366  
 Sible Hedingham 191  
 see also tile-making, tilers, and tiler  
 wasters see wasters  
 kilns and kiln-sites 3, 10, 37  
**Essex** 189, 190, 356  
 Ardleigh 190-92, 203, 207, 210, 368  
 Blackmore End 90, 109  
 Braintree 190-91  
 Broomfield 190  
 Buttsbury 190  
 Castle Hedingham 190-91  
 Coggeshall 190-91  
 Colchester 8, 40, 109, 364-9  
 Colchester area, documentary evidence 364-9  
 Danbury 93  
 Dedham 190-91, 193  
 East Horndon 190  
 Gestingthorpe 190-93, 207, 210, 215  
 Gosfield 75, 77, 93  
 Great and Little Horkesley 191  
 Great Horkesley 19, 20, 92, 108, 120, 168, 174, 177, 190, 360, 370, 372-3  
 Great Totham 190-91  
 Halstead 75  
 Harlow 212, 221-2, 247, 370  
 Harlow and Latton 190  
 Hedingham 44, 102, 356  
 Hedingham-Halstead area 90  
 Hole Farm, Sible Hedingham 41, 69, 77, 100  
 Ingatestone 370  
 Lexden 190, 364  
 Loughton 190, 221-2, 247  
 Magdalen Street 108, 110, 130-31, 134, 141, 146, 170, 359, 366, 370, 372-3  
 Middleborough 32, 36, 41-2, 44, 51-2, 55-70, 86, 92, 102, 112, 316, 344, 353, 357-8, 366  
 Mile End 12, 17, 32, 56, 67, 89, 92, 94, 96, 98, 100, 102, 106, 110, 146, 365, 367  
 Purleigh 190  
 Ramsden Bellhouse 190  
 Rayleigh 370, 372  
 Roman Hill House, East Donyland 368  
 Sible Hedingham 32, 75-6, 79, 83, 89, 190  
 South Hanningfield 190  
 South Woodham Ferrers 370  
 Southminster 190  
 Stifford 190  
 Stock 190, 210, 212, 218, 221, 247, 370  
 The Rookery, Great Horkesley 109  
 Thorpe-le-Soken 190-91  
 Tiptree 190-92  
 Tolleshunt Knights 190  
 Waltham Abbey 190  
 Wethersfield 190  
**others**  
 Ash, Surrey 225  
 Bessin group, France 264  
 Brede, Sussex 256  
 Canterbury, Kent 222  
 Chailey, Sussex 256  
 Cheam, Surrey 183  
 Cologne 282, 284  
 Cove, Hamps 212, 225  
 Delft 229
- Denby, Derby 254  
 Denham, Bucks 70  
 Flitwick, Beds 141  
 Frechen 282, 284  
 Fulham, London 246, 288, 290  
 High Halden near Ashford, Kent 256  
 Ipswich 27, 353  
 Lambeth, London 243, 254  
 Laverstock, Wilts 67  
 Littlethorpe, N Yorks 255  
 Low Countries 278  
 Meudon, Brittany 186  
 Norwich 366  
 Olney Hyde, Bucks 186  
 Rye, Sussex 170  
 Sankeys, Notts 256  
 Scarborough, N Yorks 74  
 Silkstone, S Yorks 255-6  
 Southwark, London 229  
 Staffordshire 251, 354  
 Tyler Hill, Canterbury 70  
 Utrecht 267  
 Woolwich, London 215, 288  
 King, Edward 19  
 King John's Hunting Lodge, Writtle, Essex 76, 113, 138  
 King's Lynn, Norfolk 18, 193-4  
 Kingston-type ware 13, 81, 89, 126, 182-3  
 Kingston upon Thames, Surrey 182  
 Kingswood Heath, Essex 365  
 Kleve, Germany 292  
 Klosters Museum, Bruges 280  
 Knight jugs 74-5, 87  
 Koblenz, Germany 288  
 Krefeld, Germany 292
- L**  
 lace making 215  
 Lackford, Suffolk 24  
 ladles 4, 276  
 Lambeth, London 188, 191, 232, 237  
 Lambeth delft 251  
 lamps 22, 24, 30, 38-9, 55-6, 68, 316  
 Landbeach, Cambs 89  
 Langenhoe, Essex 17, 89, 178  
 Langerwehe, Germany 281, 278  
 Langerwehe jugs 270  
 Langerwehe stoneware 13, 112, 128, 134, 141, 277-82, 296, 322-3, 325, 343, 362  
 larding jar 264  
 late slipped kitchenware 13, 254-5, 362  
 Latimer, John 230  
 latrines 3-4, 7, 9-10, 194, 207, 256, 288, 306, 309, 328, 334  
 Latton, Essex 110  
 lavabos 141-2, 152, 176  
 ead rivet repairs 82  
 leather-working 18, 366  
 Leeds 253  
 Leghorn, Italy 305  
 Leicester 308  
 Letchworth, Herts 89  
 Lewes, E Sussex 18  
 Lexden 17, 296, 364, 367  
 Ley, William, Richard, and Richard 368  
 lids 39, 44, 67, 74-5, 82, 83, 101-2, 104-5, 138, 141, 143, 146, 154-6, 166, 168, 170, 176, 185-6, 193, 203, 210, 214, 225, 228, 234, 252-5, 266-7, 281-3, 296, 300, 303-4, 368-9  
 Ligurian *berettino* wares 296  
 Limburg, Holland 265  
 Lincoln-type ware 13  
 Lindisfarne, Northumbria 222  
 Lion Walk, medieval street 3  
 Lion Walk excavation 1, 3-7, 10, 14, 21-5, 31, 33, 39-40, 41, 51, 55, 67, 73, 84, 86, 92, 98, 94, 101, 104, 111-13, 141, 150, 154, 156, 165, 207, 210, 229-32, 234-6, 238, 240-42, 244, 247, 258, 260-61, 281, 290, 296-7, 309, 311-12, 322, 334, 371-2  
 overview 3  
 Lion Walk Congregational Church excavation 4  
 Lion Walk ditch see town ditch  
 Lisbon, Portugal 298

- Liverpool 253  
 Liverpool wares 250  
 London 14, 17-19, 24-5, 31-2, 36-7, 55, 69-71, 79, 84, 87, 89-91, 104, 112, 127-8, 165, 170, 175, 178, 180, 182-4, 186, 188-90, 221, 228-9, 237, 245-7, 250, 254, 258, 266, 277-8, 290, 294, 296, 298-9, 304-5, 307, 353, 355, 366, 370  
   waterfronts 83  
 London delft 251  
 London fine ware 164  
 London Mint site 296  
 London stoneware 247, 344  
 London wares 265, 355  
 London-type coarsewares 73  
 London-type ware v, 6, 9, 13-15, 72-4, 76, 79, 81-2, 86-7, 89, 100, 106, 112, 127, 129-30, 138, 150, 164, 174-6, 180, 186, 265, 316, 320, 354, 358  
 Long Wyre Street excavation 8-9, 13, 31, 35, 39, 56, 106, 115, 128, 150, 152, 164-5, 182, 186, 322, 360, 371  
   overview 8  
 Long Wyre Street ware 185-6, 322, 360  
 louvers xiv, 10, 20, 72-3, 105-6, 112-13, 126, 138, 156, 159, 161, 163-6, 175, 177, 180, 364  
   East Stockwell Street 167  
   Great Easton, Essex 159  
 Low Countries greywares 13  
 Low Countries red earthenwares 13, 138, 143, 156, 191, 266-72, 274, 362  
 Low Countries wares 13, 265-75, 355  
 Low Countries white earthenwares 12, 274, 362  
 Lower Rhine slipware 13, 222, 291-2, 363  
 Lucca, Italy 305  
 Lustre wares 13, 252, 256  
 Lyveden 87  
 Lyveden-Stannion pottery industry 39  
 Lyveden ware 87, 89-90
- M**  
 Mace, John 232  
 Maes, Nicholas 270  
 Magdalen Street (no 11), excavation 9-10, 20, 108, 110, 130, 134, 146, 170, 366, 370-72  
   overview 9  
 Maidens Tye, High Easter 168  
 Maidstone, Kent 247  
 Mainman, Ailsa 310  
*maiolica* see tin-glazed earthenware wares  
 Malaga, Spain 294  
 Maldon, Essex 17, 26, 40, 69, 71, 98, 177-8, 265  
 Maldon Road excavation 228, 369  
   overview 10  
 Manor of the More, Rickmansworth 164-5  
 Margate, Kent 258  
 Marlowe Car Park site, Canterbury 247  
 Martaban, Burma 306  
 Martabani stoneware 13, 306, 363  
 Martincamp, France 308, 334  
 Martincamp flasks 13, 20, 263-4, 362  
 Martyn, Symon 365  
 Mary Rose 308  
 Maxey-type ware 12  
 Meanee Barracks 24  
 measures 3, 17, 19, 82, 94, 104-5, 129, 251, 254, 372  
 medieval houses 8  
   stone 3-5, 9, 17, 31, 33, 55, 84, 101, 166, 281  
   timber-framed 3  
   wood and daub 5  
 medieval sandy greywares 12, 33, 36, 40, 41, 49, 52, 55, 57, 67-8, 76, 86, 91-107, 110-12, 127, 128, 130, 134, 138, 146, 164-5, 174-5, 265, 316, 320, 322, 354, 358, 365, 369  
 medieval sandy orange wares 40, 41, 90, 92, 107, 109, 115, 180, 186, 189, 192, 215, 266  
 medieval white wares 12  
 Mediterranean 'mercury' jars 13, 307-8, 363  
 merchant's marks 170, 168, 173  
 Mercia 17, 354  
 mercury 4, 8, 13, 290, 308, 334  
 Mercury 282  
 Merida, Spain 297  
 Merida-type ware 13, 297  
 Merovingian pottery 258, 354  
 Mersea Road 24  
 Messing, parish of 369  
 metal vessels 92, 97, 117-18, 122, 127-8, 138, 150, 174, 176, 354, 365-6  
 Metropolitan slipwares 13, 110, 189-94, 203, 221-5, 235, 247, 351, 270, 361  
 Middleborough excavation xiv, 1, 3, 8, 20, 39, 41-2, 44, 47, 51-2, 55, 57-70, 86, 92, 94, 96-8, 100, 102, 106, 110, 112, 115, 129, 146, 150, 163-5, 207, 209-210, 219-21, 230, 287, 300, 316, 344, 358, 361, 364-7  
   overview 8  
   recording system 8  
   see also kilns and kiln-sites  
   see also potter's workshops  
 Mile End, parish of 367  
 Mile End (Colchester) coarseware 92  
 Mile End kiln-site, see kilns and kiln-sites  
 Miletus ware 308  
 mills, water 8  
 Mill Green coarseware 12, 92  
 Mill Green polychrome ware 164  
 Mill Green ware 8-9, 13, 15, 49, 67, 73, 83, 86, 89-92, 94, 101, 104, 109, 112-13, 115, 127-8, 138, 150, 152, 154, 166, 174-6, 180-82, 262, 316, 322, 354, 360, 370, 372-3  
 mint, in Colchester 17  
 miscellaneous early medieval Low Countries white wares 12, 266  
 miscellaneous earthenwares 13, 252, 257  
 miscellaneous Iberian green glazed wares 13, 297  
 modern English wares 13, 250-57  
 moneyboxes 186, 217-18, 227-8  
 Montelupo 8, 13, 235, 299-301, 304, 334  
 Moot Hall 9, 17-18, 31  
 Morant, Philip 230, 337  
   map of 1748 3-4, 6, 8, 232, 337  
 Mount Bures, Essex 300, 303-4  
 Mucking, Essex 23-4, 310, 353  
 mugs 7, 113, 122, 128-9, 134, 146, 168, 184, 210, 212-13, 222, 225, 228, 243, 246-8, 250, 267, 270, 278, 280, 282-4, 287-8, 325, 328, 351  
 Murphy, P M 129, 219  
 Museum of Folklore, Ghent 159  
 Museum of London 82, 304, 307  
 Musty, J 190  
   kiln types 57
- N**  
 Naylinghurst, Essex 76, 79, 89  
 Netherlands, Anglo-Netherlands and English tin-glazed earthenware 228-45, 361-2  
 neutron activation analysis 20, 109, 112, 177, 296, 301, 370-73  
 Nevers, France 232  
 New Market Tavern 8, 219, 344  
 Newcastle 19, 254, 256  
 Nieder Selters, Germany 293  
 Nieder Selters-type bottle 13, 293  
 Niederrheinisches slipware 292  
 nonconformity in Colchester 19  
 non-local slip-painted wares 185-6, 360  
 Normandy (red-painted) wares 12  
 Normandy stoneware 13, 264  
 North Devon gravel-tempered ware 13, 245, 355, 362  
 North Elmham, Norfolk 89-90  
 North French glazed ware 5  
 North French monochrome ware 362  
 North Hill 254, 261, 359-60  
 North Hill, excavation of 1965 22  
 North Holland slipware 13, 267, 270, 272-4, 292, 362  
 North Italian marbled slipware 13, 299-300, 363  
 North Italian redware fabrics 301  
 North Shoebury, Essex 89  
 Northampton 39  
 Northgate Street 303, 363  
 Norwich 17-18, 28, 30-32, 89-91, 104, 152, 154, 170, 177, 193-4, 222, 229, 234, 237, 247, 250, 252, 270, 292, 355, 366  
 Norwich Castle 19  
 Nottingham stoneware 247  
 Nottingham/Derbyshire stoneware 13, 252  
 Nottingham ware 87  
 Nuremberg tokens 5, 337
- O**  
 Oath Book of Colchester 277, 322, 364  
 oil  
   jars 300-301, 304-5  
   lamps 159  
   shops 301, 303, 305  
 Old Custom House Quay, London 301  
 Old Heath 258, 260  
 olive  
   jars 12-13, 295-7, 301, 343, 363  
   oil 300-301, 304-5  
 oolitic wares 12, 17, 27, 37-9, 353-4, 357  
 oriental stoneware 13  
 Osborne Street excavation 11, 104, 109, 170  
 ovens 3, 7, 9-10, 13, 25-6, 42, 81-2, 97, 109, 129, 164-5, 183, 230, 261, 270, 300-301, 308, 359-60, 365  
   bronze-working 3, 10, 15  
   medieval 10  
   Roman ?corn-drying 8  
 Oxford-type ware 13, 81
- P**  
 Paffrath-type ware 4, 12, 86, 261-2, 266, 276-7, 353, 362  
 pancheons 143, 146, 188-9, 193-4, 196-200, 203, 225-6, 230, 232  
 pantiles 19  
 Pearce, J E 225  
 Pearlware 13, 194, 207, 254, 256, 288, 303  
 Peasants' Revolt, the 19, 322  
 pégaux 143, 262  
 Peldon, Essex 322  
 Pelham's Lane 262, 362  
 Penhow Castle 296  
 Pentlow, Essex 89  
 Petre, Sir William 207, 218  
 petrological studies 40  
 pewter lid 282-3  
 pharmaceutical  
   inscriptions 230, 244-5  
   vessels see drug jars  
 phials 255-6  
 pin, Anglo-Saxon 25, 311  
 Pingsdorf, Germany 276  
 Pingsdorf-type ware 12, 265-6, 276, 353  
*Pinten* 284-5  
 pipkins 9, 73, 82-4, 138, 143, 154, 177, 188-9, 191-2, 207-210, 225-6, 228, 261, 267-8, 270, 272, 368  
 Pisa 299-300, 308  
 pit groups 15, 192, 228-30, 232, 234-5, 264, 267, 290, 309, 328, 331  
 plague 1, 19, 309  
 plates 36, 40, 73, 110, 150, 194, 215, 222, 225, 235, 237-43, 251-4, 281, 294, 296-7, 306  
 Pleshey Castle, Essex 69-70, 79, 89  
 pomander 217-18  
 Poole, Dorset 19, 245, 296  
 Pope, John 366  
 Popelote, John, Matilda, Nicholas, Thomas 367  
 Popelyn, John 364  
 porcelain 11, 13  
   see also Chinese porcelain, English porcelain  
 porringers 202-3, 225-6, 228, 243, 248, 270-71  
 Portuguese *maiolica* 13, 295, 297, 363  
 post-medieval red earthenwares 5, 13, 90, 113, 149-50, 177, 188-222, 225, 232, 247, 256, 266, 288, 290, 328, 331, 328, 334, 337, 360, 368-9

- pots, buried upright 8, 98, 129, 221, 361  
 potter's workshop  
   Middleborough 8, 47, 57, 67, 86, 92, 126, 357  
 Potteries *see* kilns and kiln-sites  
 potters 191, 282  
   Andries,  
     Jasper 229, 366  
     Lucas 234  
   Balaam, William 248  
   Bonnard, Jonathon 366  
   Crouchman, Thomas 18, 366  
   Dorant, Edward and wife 368  
   Emens, Jan 282  
   Glide, Thomas 368  
   Hacch, Richard 366  
   Harper, Thomas 366  
   Hassells and Keeling 366  
   Ifield, Henry 247  
   Italian 301  
   Ley, William, Richard, and Richard 368  
   Ligurian 296  
   Middleborough 64  
   migration of 69  
   of the Colchester area, documentary evidence for 364-9  
   of Great Horkesley parish 110, 367  
   of Raeren 288  
   of Staffordshire 19, 251  
   of Tiptree 369  
   of Westerwald 288  
   Popelote,  
     John 110, 367  
     Thomas 367  
   Pottere,  
     Hugh 365  
     Johanne le 93  
     John le 365  
   Thursteyn, Richard 364, 366  
   Vol, Abraham 366  
   Willmott, Joshua 366  
 Potters Row, Tiptree 369  
 pottery  
   cataloguing system 3  
   classification and methods 12  
   confusion with Roman 33  
   dating and ceramic phasing 14  
   development and supply 353-4  
   fabric codes for Essex 12  
   illustrated pottery, concordance 357-63  
   impressions in pottery, plant 129, 57  
   impressions in pottery, textile 129  
   imports as evidence of trade and cultural links 354-5  
   late Roman shelly wares 33  
   middle Saxon, in Colchester 25  
   quantification, methodology 11  
   recommendations for future work 355-6  
   reference collections 13  
   residual 31, 64, 84, 86, 92  
   seconds 284  
   pottery dealers 250-51  
   Pottland, Germany 290  
   Pudding Lane-type North French glazed ware 5, 13, 362  
   punch bowls 243, 267  
   puzzle jugs 81, 217-18  
  
**Q**  
   quarrying, sand 10  
   Queen Street 75, 166, 359-60  
   Queensware 13, 250-54, 288, 306  
     *see also* Creamware  
   Quintyn, Alexander 365  
  
**R**  
   Raeren, Belgium 280-81, 288  
   Raeren stoneware 13, 113, 128, 134, 146, 150, 168, 184, 232, 267, 271, 280-84, 288, 294, 296, 308, 323, 325, 328, 343-4, 355, 362  
   Ramsgate Maritime Museum 301  
   Rattlesden, Suffolk 89  
   Ravenna Cosmography 17  
   Rawmarsh near Rotherham, S Yorks 256  
   Rawmarsh-type bottle 255  
  
   Rayleigh pottery industry 12, 109  
   Rayleigh ware 372  
   Red Lion Inn/Hotel, the 3-5, 19, 230, 232, 250-51, 366  
   Red Paper Book of Colchester, the 364  
   Red stoneware 13, 251-2  
   Rhenish stonewares 177, 230, 265, 277-88, 328, 355, 367  
     *see also* Fabrics 45A-45F, 45K  
   Richard II 322  
   Rijksmuseum, Amsterdam 237  
   Ripon, N Yorks 255  
   Risby Gate, Bury, Suffolk 251  
   Rivenhall, Essex 35, 37, 70-71, 76, 79, 81-4, 87, 89, 168, 178  
   River Colne 17  
   River Eifel 278  
   roasters 228  
   robber trenches 1, 3-9, 15, 26-7, 31, 33-4, 36, 38-40, 67, 83-4, 86, 92, 111, 261-2, 266, 276-7, 316, 322-3, 337, 344, 351  
   Rochester, Dunstan and Samuel 368  
   Rochester, Kent 19, 247  
   Rogers Junior, John 250  
   roof furniture xiv, 106, 163, 166-8, 180, 364  
   Rope Lane factory, Ipswich 248  
   Rotterdam 19, 265, 267  
   Rouen 79  
   Rouen style 354  
   Rouen-style baluster jugs 73, 79, 81, 86, 94, 175, 320  
   Rouen-type ware 13, 260-62, 362  
   Rovers Tye 365  
   Roydon, Norfolk 89  
   rubbish disposal 309  
   Rye ware 170  
  
**S**  
   Sadler 201, 203  
   Sadler, Jonathon 203  
   Saffron Walden, Essex 70, 89  
   Saintonge *pégaux* 9, 154, 168, 176, 267  
   Saintonge ware 4, 5, 8-9, 12-13, 150, 258, 260, 262, 322, 325, 328, 344, 362  
   Salcott, Essex 265  
   salting jar 264  
   Sandwich, Kent 258, 308  
   sanitary wares 13, 252, 256  
   Savona, Italy 296  
   Saxon brickearth fabrics 21-3, 258, 310, 357  
     *see also* Fabrics 2, 3, 4, 4A, 4B, 4C  
   Saxon vegetable-tempered ware *see* vegetable-tempered ware  
   Scarborough, N Yorks 74  
   Scarborough pottery industry 91  
   Scarborough ware 13, 74-6, 87, 89, 91, 146, 354-5, 358  
   *Schalenumen* 310  
   *Schlickung* 12, 22-3  
   Scone, Perth and Kinross 18  
   Scott, Samuel 301  
   Seal House waterfront, London 164  
   seals, cloth 4, 8, 128  
   Sellers, Elizabeth 90  
   Seville (*Cuerda Seca*) 13, 232, 234, 295-7  
   Seville *maiolica* 296, 363  
   Seville tin-glazed pottery 296  
   sgraffito ware 11, 12, 166, 168  
   Sheepen Farm 218  
   Sheepen Farm siege fort 207, 212, 219, 361  
   Shelton, Staffordshire 251  
   Shemyng, John 134  
   Ship Inn, the 369  
   Sible Hedingham, Essex 89-91  
   Siegburg, Germany 277  
   Siegburg stoneware 13, 112, 128, 134, 184, 263, 277-8, 280, 288, 293, 322, 355, 362  
   Siege of Colchester, the (1648) 6, 15, 19, 228, 230, 237, 334  
   Sir Isaac's Walk 358  
   site codes, explanation 3  
   site periods, explanation 5  
   skillets 42, 44, 47, 49, 56, 68, 104, 143, 203, 207-210, 215, 225-6, 267, 269, 272  
   slip painting 108  
   slipped kitchenware 189, 250, 252, 254-6, 362  
  
   Snell, Edward 251  
   South Gate 9, 366  
   South Netherlands *maiolica* 13, 274-5, 362  
   South Woodham Ferrers, Essex 109, 372  
   Southampton 18, 164, 299, 304, 308  
   Southend, Essex 89, 370  
   Southey Green Works, Sible Hedingham 191  
   Southwark, London 182, 366  
   Spanish lustrewares 8, 13, 20, 294-6, 363  
   Speed, John, map of 1610 6, 8  
   Spendrite, excavation 10, 31  
   Spice  
     container 308  
     mill 308  
   Spilsby, Lincs 170  
   spindlewhorls 25, 56, 282  
   spouted pitchers 26, 28, 33-4, 44, 51, 55, 57, 63-4, 68-69  
   Squyer, Alan 367  
   St Albans 70  
   St Botolph's Priory 1, 3, 17, 366  
   St Giles' Church excavation 10  
   St John's Abbey 1, 10, 15, 17, 19, 30-31, 34, 41, 52, 170, 364  
     overview of excavations 10  
   St John's Green 360  
   St John's Street 359-62  
   St John's Street (no 11) 301  
   St Mary at Ospringe, Kent 159  
   St Mary Magdalen 3  
   St Mary's Hospital 307  
   St Mary's rectory 98  
   St Neots-type ware 5, 9, 12, 32-3, 36, 39, 69, 84, 353-4, 357  
   St Nicholas' Church excavation 31, 357  
   St Nicholas' parish 366  
   St Nicholas' Priory, Exeter 245  
   St Omer, France 18  
   St Osyth, Essex 93  
   Staffordshire slipware 344, 351  
   Staffordshire stoneware 207, 250  
   Staffordshire wares 355  
   Staffordshire white stoneware 194, 252, 288  
   Staffordshire-type iron-streaked earthenware 13, 249  
   Staffordshire-type slipware 13, 248-9, 362  
   Staffordshire-type white earthenwares 13, 252-4, 256-7  
   Staffordshire-type white stoneware 13, 252-3, 256  
   Stamford, Lincs 26, 33, 87  
   Stamford ware 5, 9, 12, 32-4, 36, 69, 77, 84, 86-7, 353-4, 357  
   stamps 5, 9, 24, 26, 30-32, 37, 52, 69, 76-7, 79-84, 86, 89-91, 101-2, 115, 127, 129, 149, 154, 165, 170, 175, 183-6, 193-4, 201, 203, 225, 247-8, 254, 256, 258, 261-2, 266, 281, 284, 287-8, 293, 300-301, 303-4, 311, 315  
   Stansted, Essex 89  
   Stansted ware 12  
   Stanwell Street 170  
   star costrels *see* Iberian/North African star costrels  
   Stebbingford, Essex 89  
   Steen, Jan 290  
   Stock, Essex 109, 188  
   Stock-type black glazed ware 13  
   Stockwell Street 18, 322  
   Stoke-by-Nayland, Suffolk 178  
   storage jars 13, 22-3, 28-32, 42, 44, 50-52, 57, 60, 62-5, 67-70, 76, 86, 92, 101-2, 104, 113, 129, 134, 138, 168, 180, 191-2, 203-7, 219-20, 230, 246-7, 252, 255, 297-8, 306, 310, 354, 368  
   strainers 154, 173, 215-16, 227-8, 270-71  
   stratified groups 1, 309-352  
     basis for selection 11, 15  
   Stratified Group 1 4, 6, 21-2, 24-5, 150, 210, 260-61, 309-310, 328, 337  
   Stratified Group 2 7, 23-5, 39, 243, 248, 267, 309-311  
   Stratified Group 3 9, 25, 31, 36, 39-40, 70, 309, 311  
   Stratified Group 4 6, 31, 35-6, 40-41, 44, 50-52, 55, 67, 70, 73, 86, 92, 94, 98, 112, 309, 311-16

- Stratified Group 5 7, 36, 41-2, 44, 55, 67, 84, 86, 309, 316-18  
 Stratified Group 6 7, 52, 54, 86, 309, 316, 319-20  
 Stratified Group 7 9, 73, 75, 86, 94, 97-8, 100, 112, 128, 186, 309, 316, 321-2  
 Stratified Group 8 9, 115, 127, 309, 322-3  
 Stratified Group 9 1, 6, 15, 19, 92, 112, 128, 134, 141-2, 146, 149-50, 156, 165, 170, 172-3, 183, 267, 277, 280, 309, 322-5  
 Stratified Group 10 6, 108, 112, 118, 128, 130, 138, 141-2, 152, 154, 165, 173, 261, 267, 270, 272, 280, 294, 309, 322-4, 326-8  
 Stratified Group 11 4, 73, 83, 92, 126, 143, 172, 183, 277, 309, 325, 329  
 Stratified Group 12 126, 143, 150, 154, 184, 186, 192, 309, 325  
 Stratified Group 13 3, 10, 150, 192, 210, 270, 274, 280, 309, 328, 330-31  
 Stratified Group 14 7, 141, 146, 154, 156, 185, 188, 280, 282, 309, 328  
 Stratified Group 15 7, 130, 134, 150, 170, 188, 270, 275, 282, 309, 328-9, 332-3  
 Stratified Group 16 6, 122, 128, 192, 194, 203, 207, 210, 212, 267, 309, 331, 334  
 Stratified Group 17 9, 194, 200, 203, 207, 210, 212, 228, 237, 270, 272, 288, 309, 334-7  
 Stratified Group 18 5, 188, 210, 212, 228, 262, 264, 267, 270, 274, 282, 284, 287, 292, 299, 309, 334  
 Stratified Group 19 4, 188, 228, 230, 232, 234, 284, 288, 290, 309, 334, 337-8  
 Stratified Group 20 4, 188, 203, 207, 210, 217-18, 228, 232, 234-5, 237, 244, 247, 267, 280, 284, 287-8, 292, 297, 309, 334, 337, 339-44  
 Stratified Group 21 3, 8, 192, 194, 203, 210, 212, 215, 222, 225, 228, 237, 243, 246, 267, 270, 274, 282, 287-8, 292, 297, 300, 309, 344-9  
 Stratified Group 22 4, 192, 194, 200-201, 207, 215, 225, 243, 248, 288, 306, 309, 350-51  
 Stratton, Beds 89-90  
 Stretham, Cambs 89  
 Sudbury, Suffolk 32  
 sugar-refining jars 210  
 Sunderland 19, 254, 256  
 Surrey/Hampshire Border white ware *see* Border ware  
 Surrey white wares 12, 183  
 Sussex inlaid slipware 13, 250, 252, 256, 362  
 Swansea 253, 256  
 Symonds, Robin *xiv*, 22  
 syrup jars 210
- T**  
 tankards 212, 223, 246, 252, 277, 288, 284  
 tanning 8, 18, 366  
 Tating ware 12  
 Taylors Arms, the 251  
 teapots 251-4, 257  
 textile 18, 56, 215, 303, 305  
 Thames Valley 37  
 Thaxted, Essex 89, 176  
 The Rookery kiln-site *see* Mile End kiln-site  
 Thetford, Norfolk 28, 32, 76, 86, 89-90  
 Thetford-type wares 3, 5, 6, 9, 11-12, 17, 20, 25-6, 28-32, 35-6, 39-41, 56, 68-9, 71, 84, 86-7, 261, 311, 353-4, 357  
 Thomson, R G *xiv*, 308  
 Thorpe-le-Soken 191  
 parish of 368-9  
 Thursteyn,  
 Anastatia 366  
 Joan 366  
 Richard 364, 366-7  
 Thurston,  
 Edmund 230  
 Hannah 230
- tile-making  
 Ardleigh, parish of 368  
 Colchester 364  
 Greenstead 365  
 Kingswood Heath 365  
 tiled stoves 228  
 tilers 110  
 in Ardleigh 203  
 in Tiptree 369  
 Pope, John 366  
 Squyer, Alan 367  
 tilery  
 John Rayner's 191  
 Wivenhoe, parish of 368  
 tiles  
 floor 10  
 Flemish 5  
 sgraffito-decorated 8  
 stove- 10  
*tinajas* 298  
 tin-glazed earthenware 13, 228-9, 331, 334, 361, 362  
*see also* Fabrics 46, 46A/C, 46B, 46B/1, 46B/2, 46C, 46D, 46D/1, 46D/2, 46E, 46F  
 Tiptree, Essex 93, 178, 191-2, 369  
 parish of 369  
 Tiptree Heath, Essex 369  
 Tollesbury, Essex 93, 177-8  
 Tolleshunt Knights, parish of 369  
 Torksey-type wares 31  
 Tower of London 70, 94  
 town ditch 73, 92  
 Lion Walk 3, 6, 31, 35-6, 40-41, 51, 67, 86, 94, 104, 138, 142, 146, 309, 311, 371  
 town wall 1, 3, 6, 8-9, 17, 19, 30, 39, 57, 92, 110, 112, 134, 149-50, 188, 219, 246, 267, 300, 324-5, 366, 370  
 bastions 6, 19  
 refurbishment of *c* 1400 6, 15, 141-2, 156, 170, 183, 277, 280, 322  
 trays 65  
 treen 353  
 Trinity Hall/Trinity College, Cambridge 142, 176  
 Trinity House, Colchester 3, 6, 232  
 Trinity Street 217  
 Trinity Street excavation 10, 191  
 tubular-spouted bowls 68-9  
 Tudor Green ware 13, 134, 149, 177, 183-4, 225, 360  
 Tunbridge ware 251  
 Tunbridge Wells 251  
 Tunstall, Staffordshire 251  
 turner ware 251  
 turnery wares 251  
 Tuscan redware fabrics 301  
 tygs 207, 212-13  
 Tyler Hill, Canterbury 69  
 Tyler Hill ware 108, 129, 159  
 Tyler, Wat 19, 322  
 Tyneside slipware 255
- U**  
 unidentified foreign wares 362  
 unprovenanced French micaceous ware 13, 261, 362  
 urinals 7, 221, 156  
 Usk 296  
 Utrecht, Holland 215
- V**  
 Valencia, Spain 294  
 Valencian lustreware 13, 228, 232, 294-5, 310, 353, 363  
 vegetable-tempered ware 8, 23-6, 69, 310, 353, 357  
 Vermeer 215, 288  
 Victoria and Albert Museum 228, 307  
 Vince, Alan *xiv*, 108, 266  
 Vlissingen, Holland 232
- Vol,  
 Abraham 366  
 Humerston 366  
 Vole, Durrel 366  
 von Bock, Reineking 351  
 Vorratskannen 280, 282  
 Vrel, Jacob 270
- W**  
 Waldenburg, Saxony 280  
 Walker, Helen *xiv*, 90, 177  
 Waltham Abbey, Essex 37, 109, 129, 164, 307  
 Walton, Bucks 70  
 Warkworth 296  
 wasters 109, 130, 154, 168, 188, 191, 210, 215, 219-20, 368-70  
 Great Horkesley kilns 110  
 Magdalen Street kilns 110  
 Wateken 367  
 Water  
 closets 256  
 jars 305  
 sprinklers 104-5, 154, 212  
 water-pipe 214  
 Waterbeach, Cambs 84, 89  
 Waterbeach Abbey 83-4  
 Wedgwood, Josiah 250, 253-4  
 Wedgwood-type products 257  
 Weeley, Essex 89, 178  
 Werra slipware 13, 215, 291-2, 363  
 Werra stoneware 344  
 Werra ware 308  
 Weser, Germany 334  
 Weser slipware 13, 290-292, 344, 363  
 Weser ware 290, 292, 308  
 West Bergholt, Essex 164, 178, 180  
 West Donyland, parish of 364  
 West Mersea, Essex 178, 359  
 West Stockwell Street 20, 294, 307  
 West Stow, Suffolk 353  
 Westerwald, Germany 288  
 Westerwald stoneware 13, 207, 210, 222, 235, 246-7, 251, 288-9, 293, 337, 343-4, 351, 363  
 Westminster 18  
 Wethersfield, Essex 191  
 wheel-thrown Frankish sandy wares 13, 25, 258, 260-62  
 Whieldon, Thomas 253  
 Whieldon-type earthenware 250  
 Whieldon-type wares 13, 250, 252-3  
 whistles 227-8, 260, 262  
 Whittlesford, Cambs 81-2, 86, 89-90  
 Wicken Bonhunt, Essex 25, 32  
 Wijck, Thomas 306  
 Willmott, Joshua 366  
 willow pattern pottery 253  
 Winchelsea, Sussex 308  
 witch bottles 129, 246, 287  
 witchcraft 170  
 Witham, Essex 77, 79, 89  
 Wivenhoe, Essex 17, 243, 251  
 parish of 368  
 Wix, Essex 89, 177-8  
 wood-turned vessels 251  
 woolcomb pot 305  
 Woolwich, London 188, 246  
 Writtle, Essex 37, 69, 83, 89, 152, 168, 178  
 Wrotham, Kent 247  
 Wrotham slipware 13, 247, 362  
 Wylde, Peter *le* 365  
 Wyre Street 130, 138, 270, 359-63, 366  
 Wyre Street Arcade site 20, 297
- X**  
 X-ray fluorescence 290, 308
- Y**  
 Yarmouth, Norfolk 18  
 Yellow ware 13, 252-4  
 York 18, 31  
 Yorkshire wares 13, 75, 256, 358





Plate 1 Hedingham ware: late 12th- and 13th-century forms. Height of tallest jug: 393 mm. [Pages 75-91]



Plate 2 Colchester-type ware; group of early style white slipped jugs, c 1250-1350. Height of left jug: 334 mm. [Pages 113-5, 172]



Plate 3 Colchester-type ware: jug sherds with Rouen-style slip decoration (early style), c 1200-1250. [Pages 112, 124, 172]



Plate 4 Colchester-type ware: polychrome jug sherds copying Mill Green polychrome baluster jugs, c 1290-1325. [Pages 115, 124-7, 172]

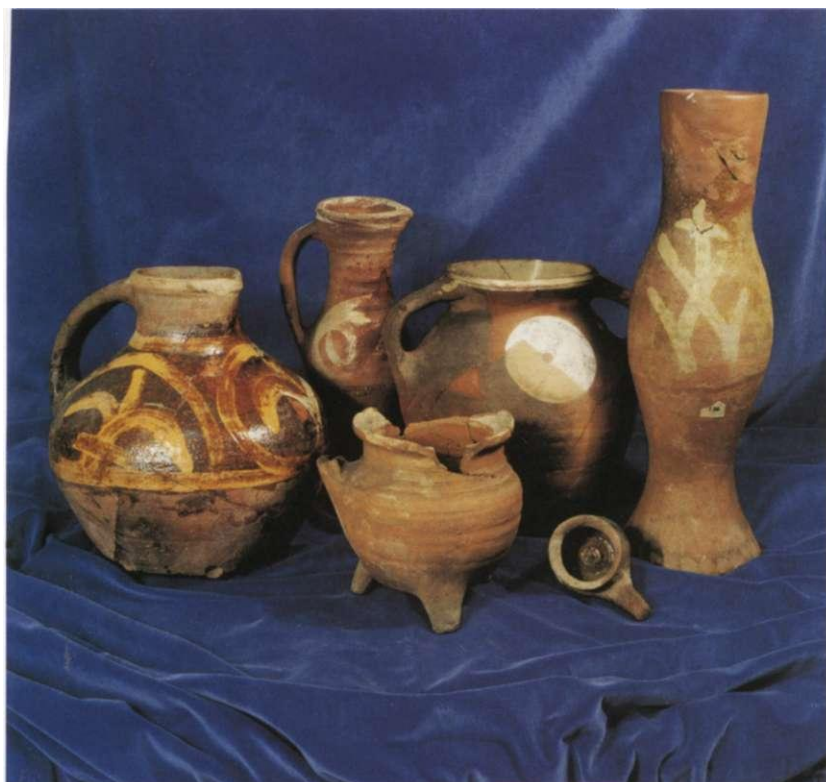

Plate 5 Colchester-type ware: vessels with middle style slip-painted decoration, 1375-1450. Height of left squat jug: 268 mm. [Pages 172-3]

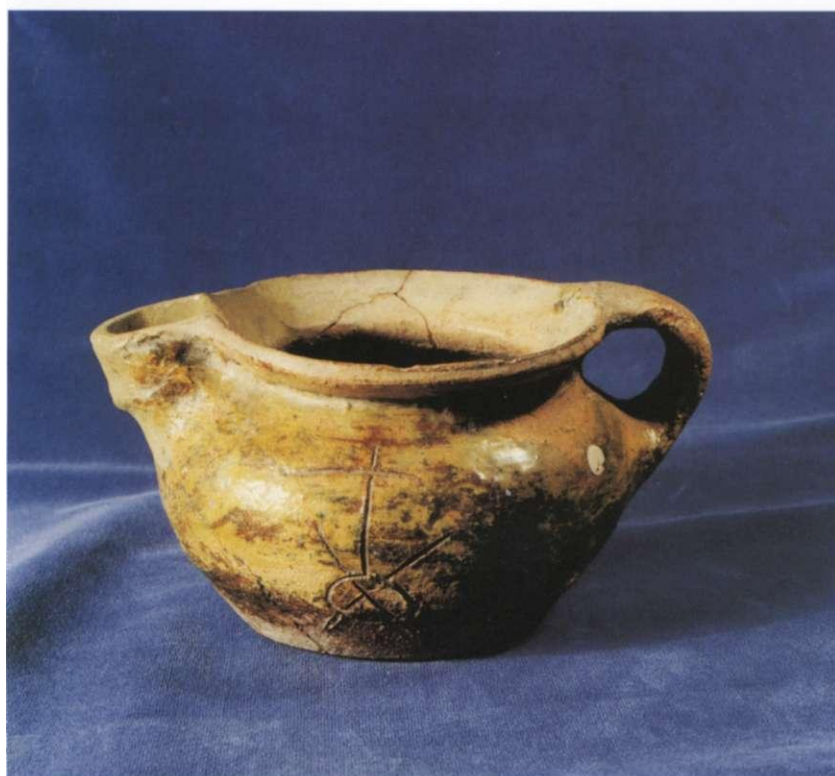

Plate 6 Colchester-type ware: jug copying Saintonge pegau form with sgraffito 'merchant's mark', c 1375-1450. Height: 118 mm. [Page 168]